

20-3120 Removing and installing viscous fan clutch

Preceding work:
Radiator removed (20-4200).

Operation no. of operation texts and work units or standard texts
and flat rates
20-5660, 20-6590

A. Model 124

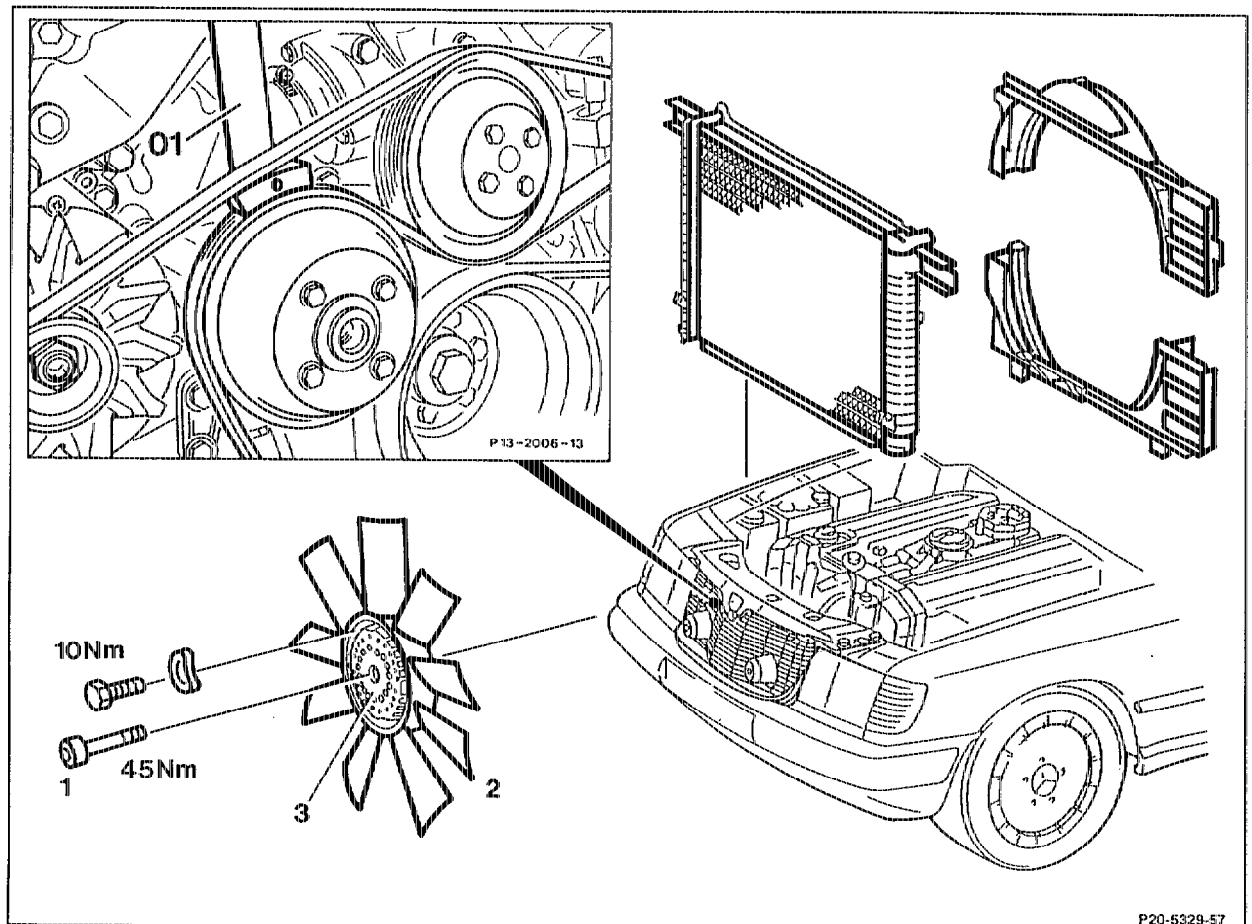

| | |
|------------------------------|--|
| Counter-holder (01) | fit on, remove, special tool 603 589 00 40 00. |
| Bolt (1) | slacken with hexagon socket and torque wrench, tighten (45 Nm), special tools 103 589 01 09 00 and 001 589 72 21 00. |
| Bolt (1) | unscrew with key 120 589 14 07 00, screw on. |
| Viscous fan clutch (3) | unbolt from fan (2), bolt on (10 Nm). |



The cast part number of the fan (2) must be positioned at the front (radiator side).

B. Model 129

Preceding work
Fan shroud removed.

Operation no. of operation texts and work units or standard texts
and flat rates
20-5660, 20-6590

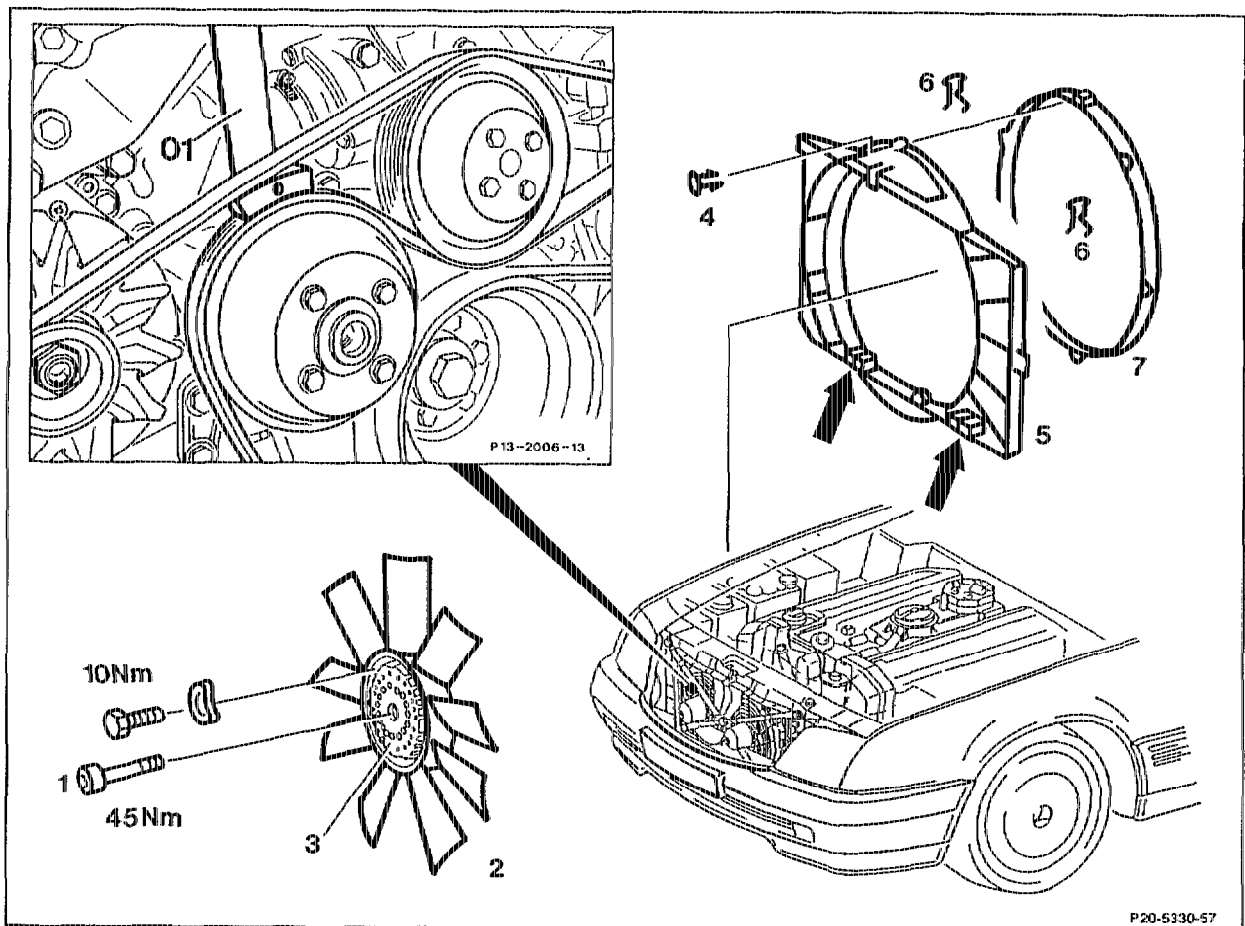

| | |
|------------------------------|--|
| Counter-holder (1) | fit on, remove, special tool 603 589 00 40 00. |
| Bolt (1) | slacken with hexagon insert and torque wrench, tighten (45 Nm), special tools 103 589 01 09 00 and 001 589 72 21 00. |
| Bolt (1) | unscrew with key 120 589 13 07 00, screw on. |
| Viscous fan clutch (3) | unbolt from fan (2), bolt on (10 Nm). |



The cast part number of the fan (2) must be positioned at the front (radiator side).

C. Model 140

Operation no. of operation texts and work units or standard texts
and flat rates
20-5660, 20-6590

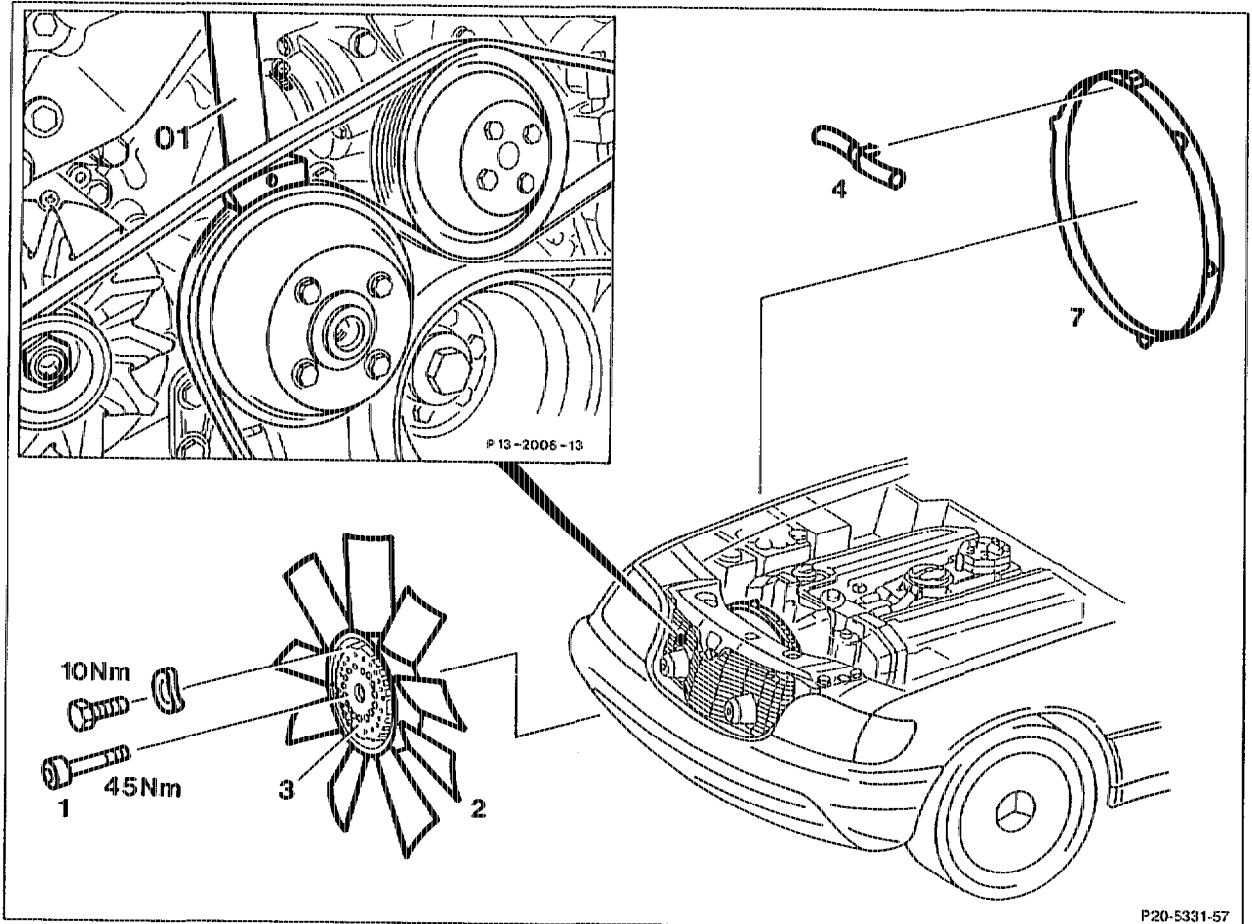

| | |
|---|--|
| Fan shroud ring (7) on fan shroud | take off, place over fan, fit on. |
| Counter-holder (01) | fit on, remove, special tool 603 589 00 40 00. |
| Bolt (1) | slacken with hexagon insert and torque wrench, tighten (45 Nm), special tools 103 589 01 09 00 and 001 589 72 21 00. |
| Bolt (1) | unscrew with key 120 589 14 07 00, screw on. |
| Viscous fan clutch (3) | unbolt from fan (2), bolt on (10 Nm). |



The cast part number of the fan (2) must be positioned at the front (radiator side).

Tightening torques in Nm

| | |
|------------------------------------|----|
| Viscous fan clutch to bearing body | 45 |
| Fan to viscous fan clutch | 10 |

Special tools

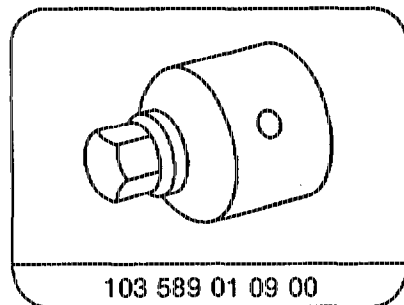
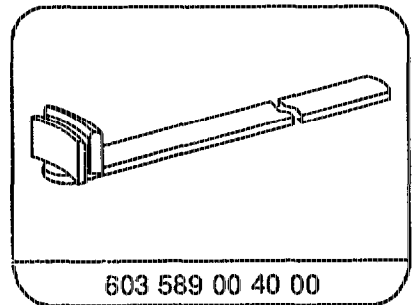
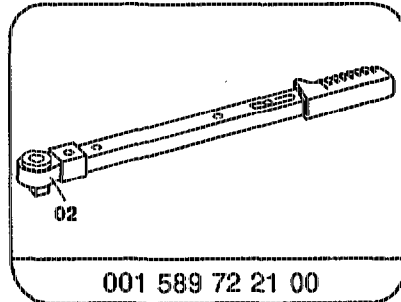
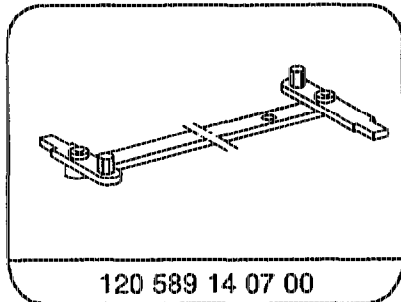

D. Model 210

Operation no. of operation texts and work units or standard texts
and flat rates
20-5660, 20-6590

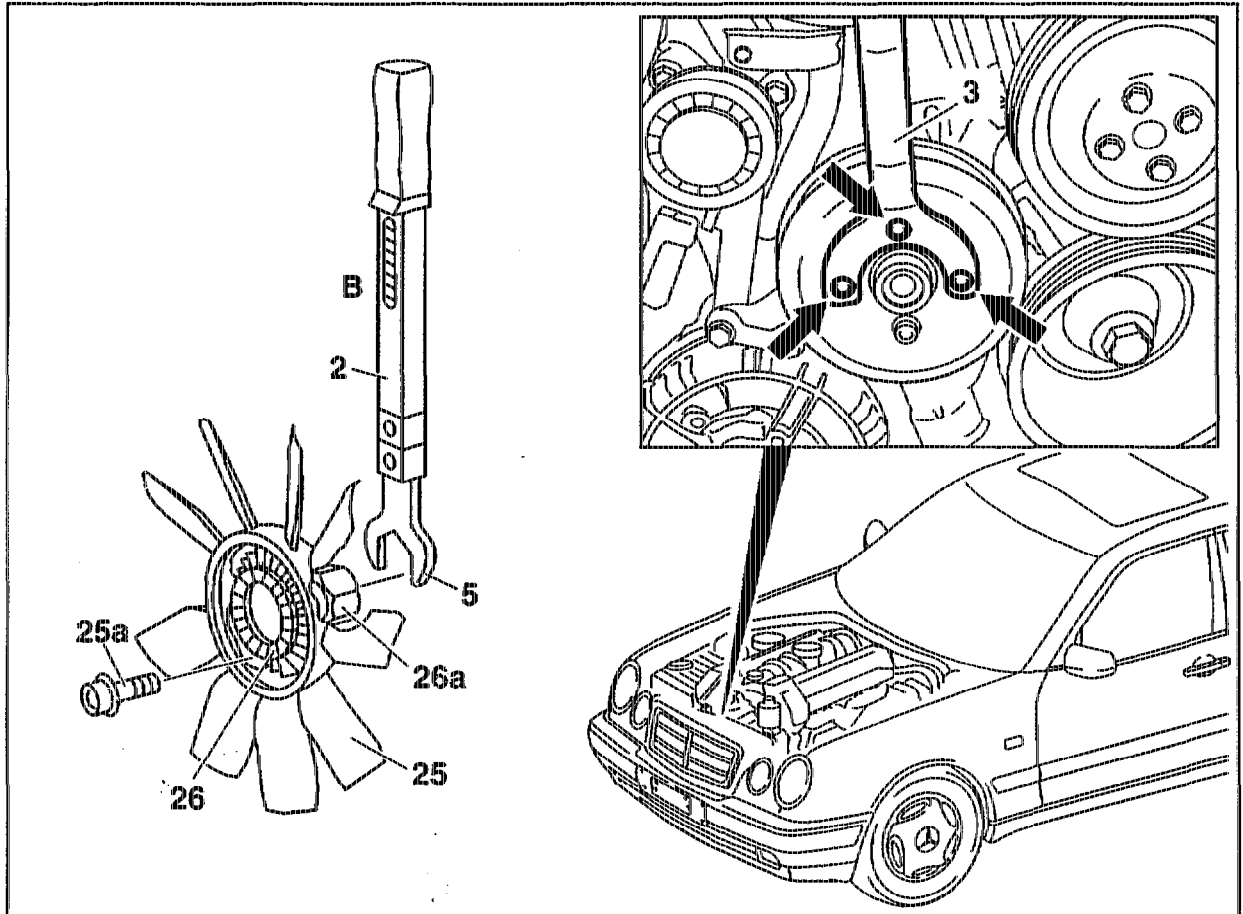

P20.40-0227-57

- | | |
|---|--|
| Counterholder (3) | fit onto belt pulley, remove, special tool 119 589 02 40 00 or 111 589 00 40 00, see note. |
| Union nut (26a) | slacken with torque wrench and open-jaw wrench bit (5), unscrew, tighten (40 Nm), special tools 001 589 72 21 00 and 111 589 02 01 00. |
| Viscous fan coupling (26) of fan (25) | unbolt, bolt on (10 Nm). |



The cast part number of the fan (2) must be positioned at the front (radiator side).

Special tools

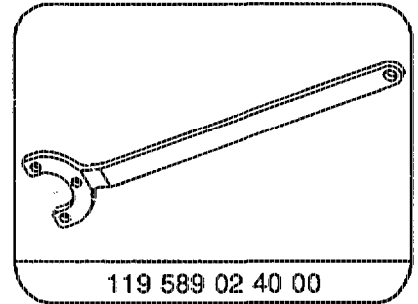
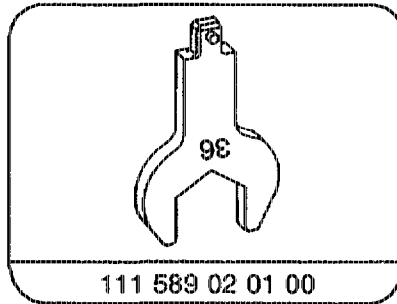
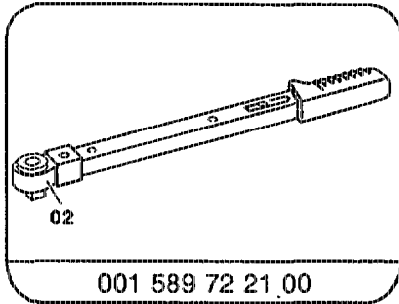

Note

Enlarge \varnothing of the holes from 10.5 mm to 11.5 mm in order to fit counterholder 111 589 00 40 00 over the hexagon bolts (arrows).

Change special tool number on tool from 111 589 00 40 00 to 119 589 02 40 00.

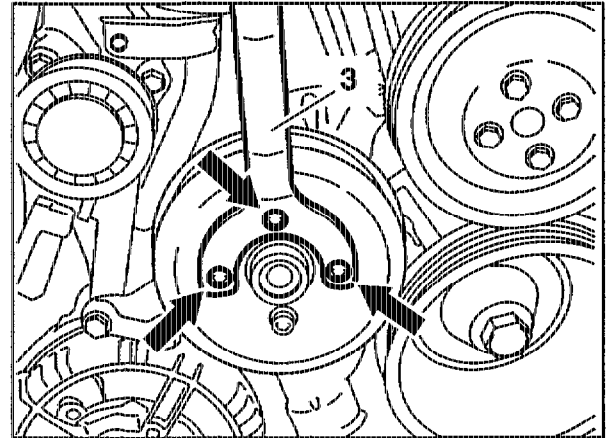

P20.40-0228-13