

20-0160 Removing oil in cooling and heating system

Preceding work:
Coolant drained (20-010).
Coolant thermostat removed (20-110).

Operation no. of operation texts and work units or standard texts
and flat rates

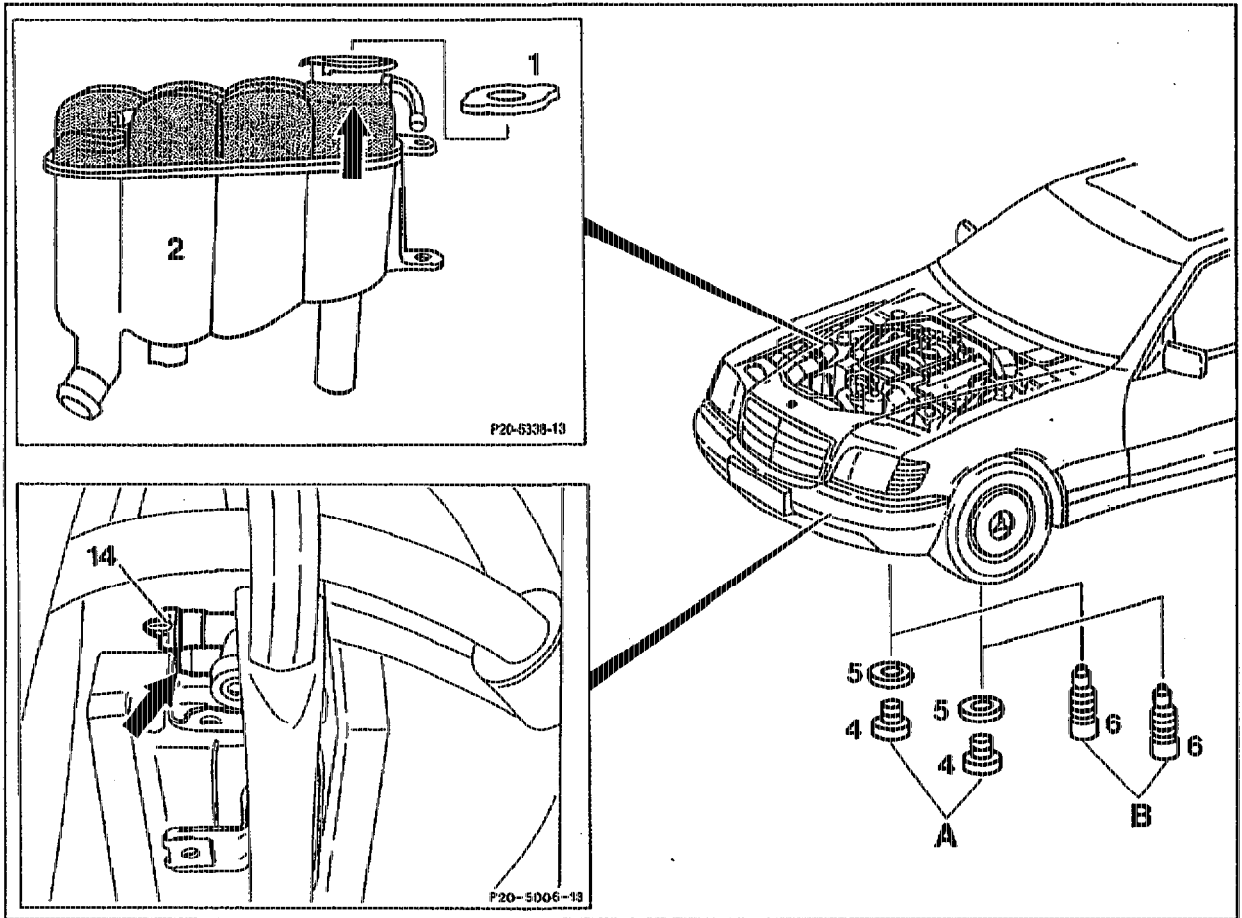

P20-5336-57

Heater controls	set to "warm" (step 1).
Coolant	drain (20-0100)
Cooling system	fill with 5 % flushing solution (step 2).
Engine	warm up to operating temperature and run for about 5 minutes (step 3).
Flushing solution	drain and fill cooling system twice with fresh water, run engine each time for about 5 minutes, drain flushing solution completely (steps 5 and 6).
Cooling system	check for leaks (20-017).

Special tool

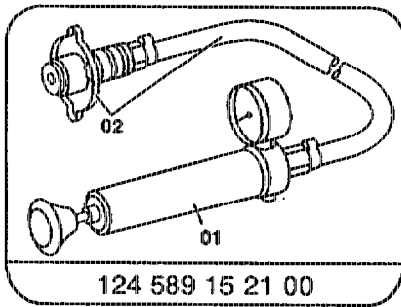

Note

The oil in the cooling system has to be removed if, for example, engine oil, ATF on models with automatic transmission or hydraulic fluid has got into the cooling system.

Removing oil

- 1 Set heater controls to full capacity.



On these models (light alloy radiator), do not use strongly alkalined cleaner such as P3 Standard (supplier: Henkel).

- 2 Drain coolant (20-0100).
- 3 Fill the cooling system with a 5 % solution of water and neutral cleaner or with a cleaner such as Neuproton 5226 (supplier: Henkel) which is suitable for cold spraying.
- 4 Warm up engine to about 80 °C by running at moderate revs and maintain at this temperature for about 5 minutes.
- 5 Switch off engine and allow cooling system to cool down to about 50 °C.
- 6 Drain solution completely.
- 7 Immediately after this, fill cooling system twice with fresh water, run until warm (about 5 minutes) and drain.
- 8 Pour in coolant (20-0100).
- 9 Check cooling system for leaks (20-0170).