

Special tools

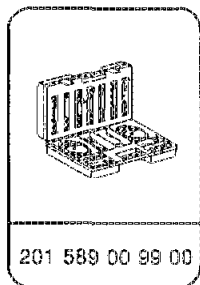
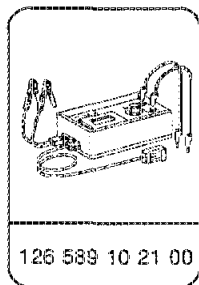

Note

Only test instrument 126 589 10 21 00 may be used for testing operations on airbag and ETR restraint systems.

If other test instruments are used, the risk arises that the restraint system may be released.

- 1 Control lamp, internal power supply
- 2 Control lamp, SRS energy accumulator
- 3 Digital display
- 4 Test sockets for external power supply and resistance testing
- 5 Test selector switch
- 6 Ground button (to test insulation resistance)
- 7 Terminal for external power supply
- 8 Leads for external power supply
- 9 Testing leads for external voltage and resistance testing.

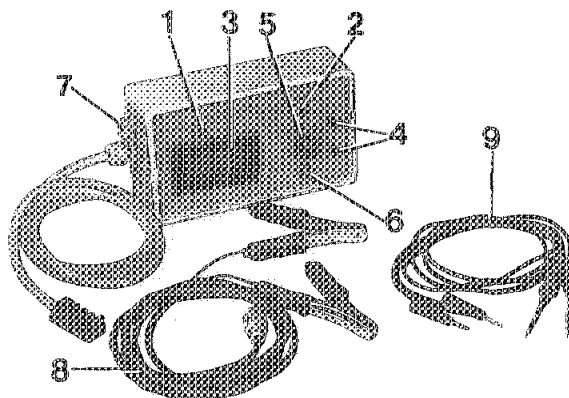

182-20672

182-20672

Connect test instrument

1 Turn ignition key to position 0, disconnect and insulate negative battery terminal.

2 Release 10-pin plug connection:
On Model 126, at front passenger's footrest or panel below footrest.

⚠ CAUTION!

Every time the 10-pin plug (X29/9) is disconnected for the purpose of connecting/disconnecting the test instrument, the ignition key must first be turned to position 0 and the negative battery terminal must be disconnected and insulated.

In this process, care must be taken to ensure that the disconnected battery terminal cannot make contact with the negative pole of its own accord.



191-34015

X29/9 10-pin plug connector

3 Disconnect 10-pin plug (X29/9) and connect test instrument with 10-pin plug on instrument lead.

4 Reconnect battery for tests.

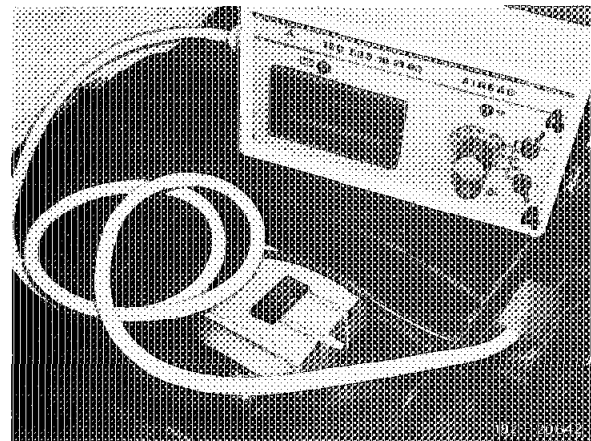

182-20642

Connect test instrument for use in testing external voltage or resistance

1 Connect lead (8) to terminal (7) and positive/negative battery terminals to provide power supply to test instrument.

2 Plug test leads (9) into test sockets (4).

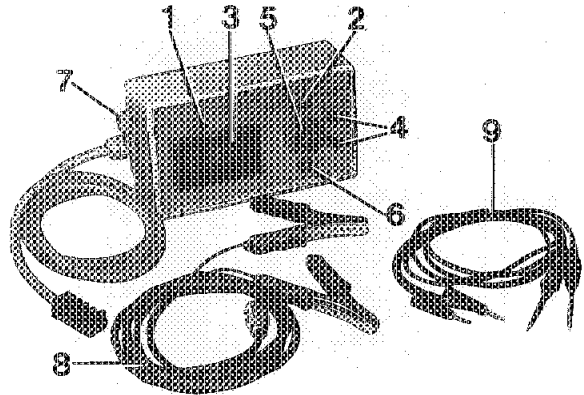

182-20672

182-20672

3 For voltage testing, set test selector switch to position 8. Display appears in volts (V).

4 For resistance testing, set test selector switch to position 9. Display appears in Ohms (Ω).

Note

If the test instrument is used for external voltage or resistance testing, it must be disconnected from the 10-pin plug-connector on the airbag/ETR lead.

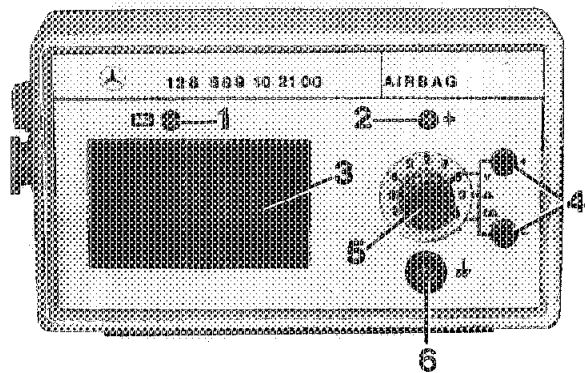

182-20671

182-20671

Model 126, type 1 (without voltage converter)

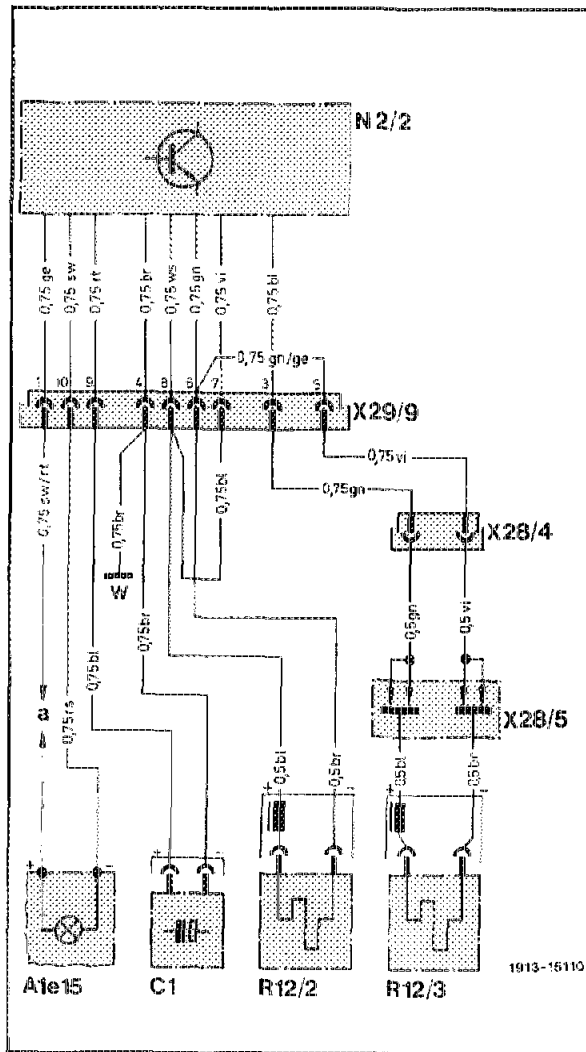

1913-15110

Circuit diagram of airbag and front passenger's ETR system with 4-way carbon brushes but without voltage converter.

A1e15	SRS MIL	W (W1)	Main ground, behind instrument cluster
C1	SRS energy accumulator	X28/4	Driver AB squib connector (2-pole)
N2/2	SRS control module	X28/5	AB squib slip ring (2-pole)
R12/2	Right front ETR squib	X29/9	Test connection, airbag, 10-pin
R12/3	Driver AB squib	a	Fusebox, terminal 15R, fuse 7, input terminal 15R to A1e15, N2/2

When the 10-pin plug (X29/9) is disconnected, pin Nos. 3, 5, 6, 7 and 8 in the lower part of the plug are short-circuited. When the connector to the ETR and airbag squibs (R12/2 and R12/3) is disconnected, the pellets are short-circuited.

Model 126, type 3 (with voltage converter and ETRs, from 09/84 onwards)

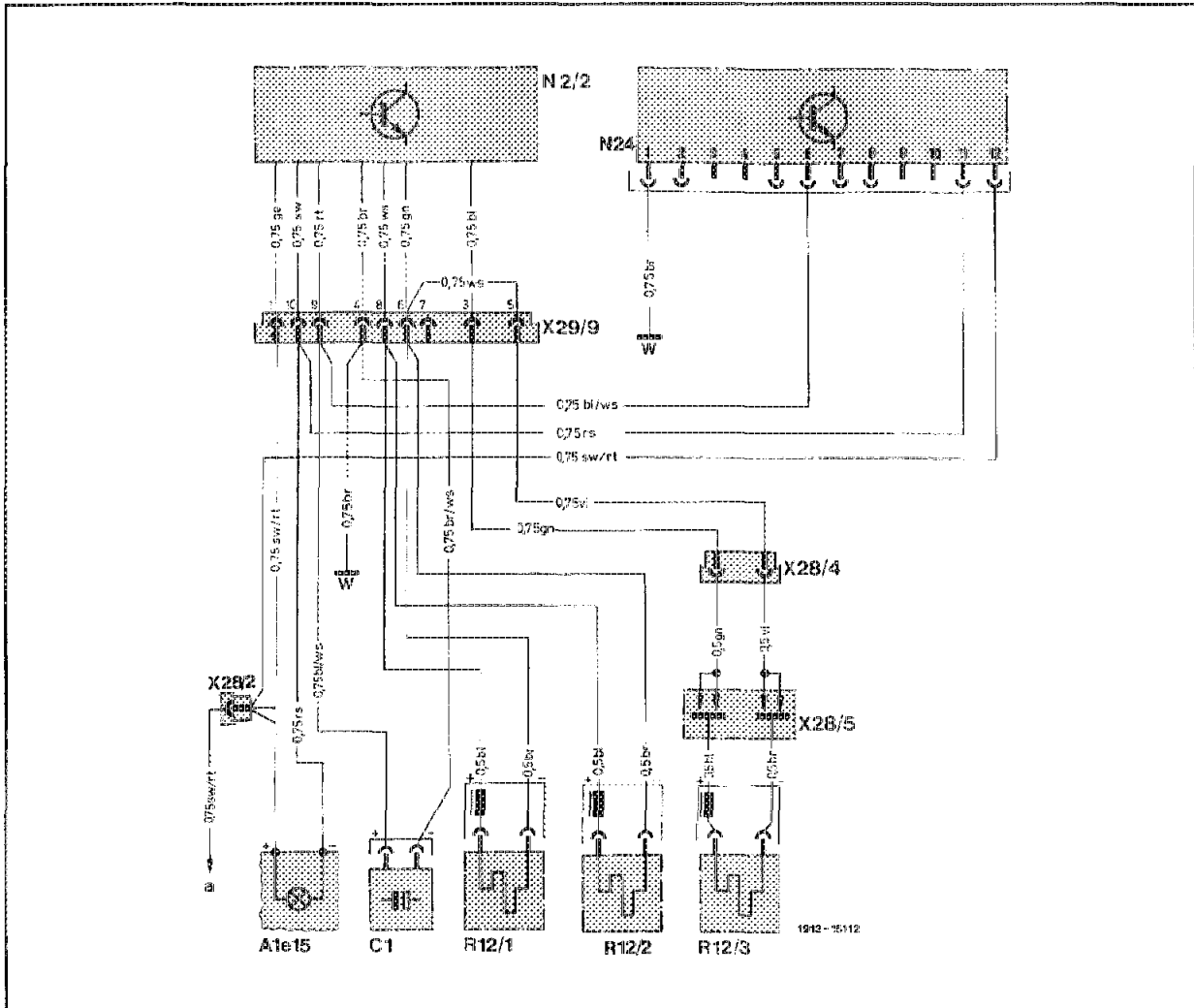

1913-15112

Circuit diagram of driver's airbag and front passenger's ETR system with 4-way carbon brushes and voltage converter

A1e15	SRS MIL	X28/2	Plug-connector, power supply to airbag with ETRs
C1	SRS energy accumulator	X28/4	Driver AB squib connector (2-pole)
N2/2	SRS control module	X28/5	AB squib slip ring (2-pole)
N24	SRS voltage converter	X29/9	Test connection, airbag, 10-pin
R12/1	Left front ETR squib	a	Fusebox, terminal 15 R, fuse 18, input, via X28/2
R12/2	Right front ETR squib		
R12/3	Driver AB squib		
W (W12)	Model 126, main ground, center console ground to N2/2, N24, C1		

When the 10-pin plug (X29/9) is disconnected, pin Nos. 3, 5, 6, 7 and 8 in the lower part of the plug are short-circuited. When the connectors to the ETR squibs (R12/1, R12/2) and airbag squib (R12/3) are disconnected, the pellets are short-circuited.

91-700 Test program, airbags and ETR (up to 08/87)

Test program

If, when the ignition key is turned to position 1 or 2 (ignition), the control lamp (A1e15) for the restraint system does not light up in the instrument cluster, proceed as follows.

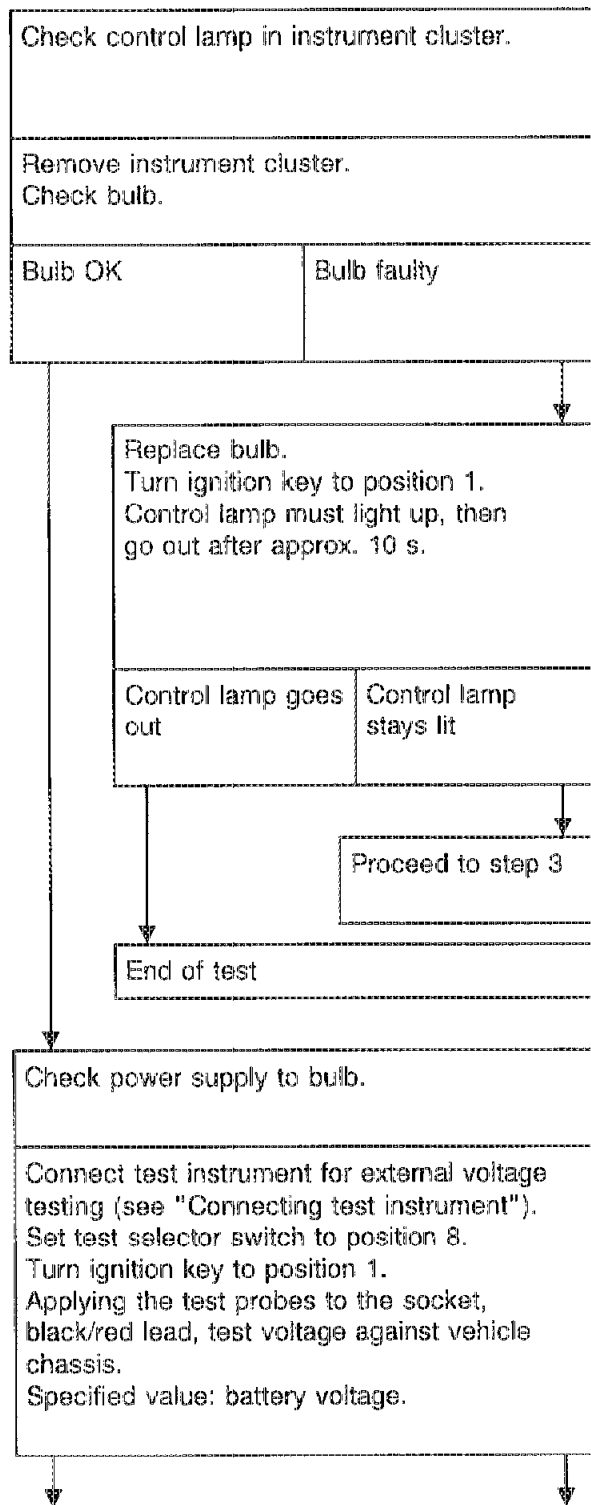

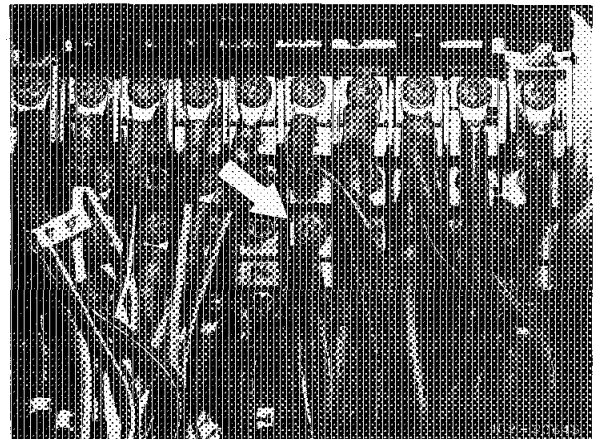
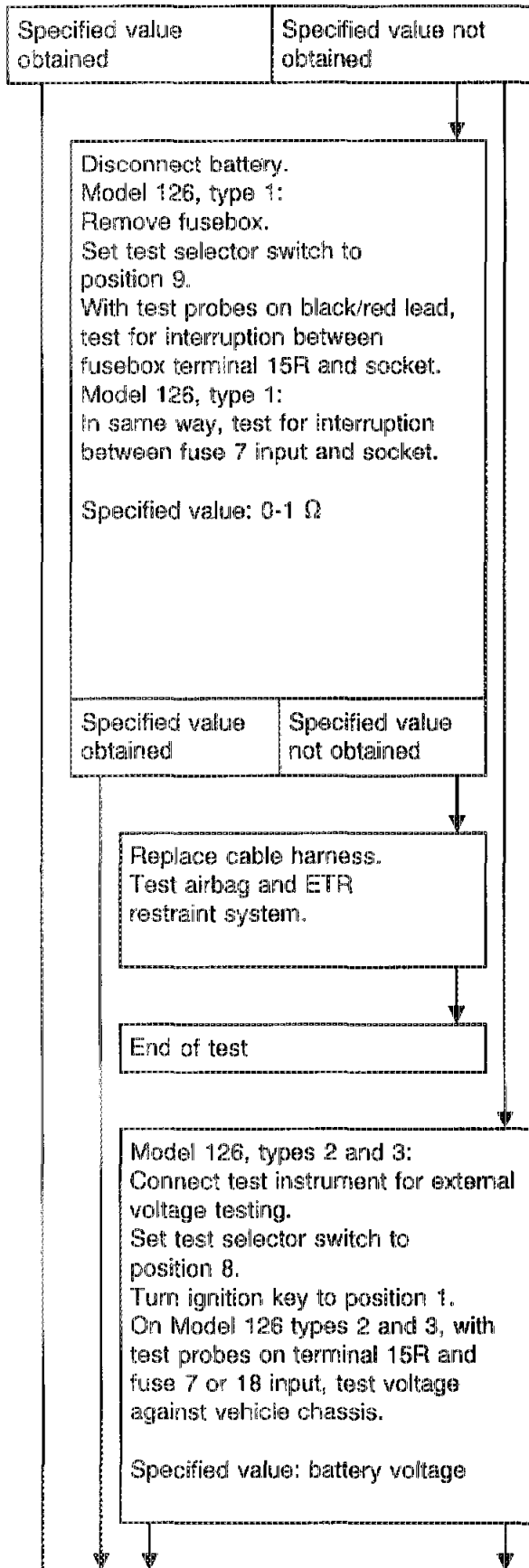

182-20648

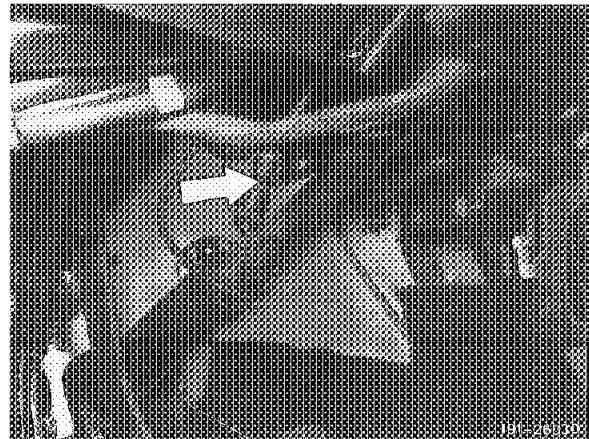
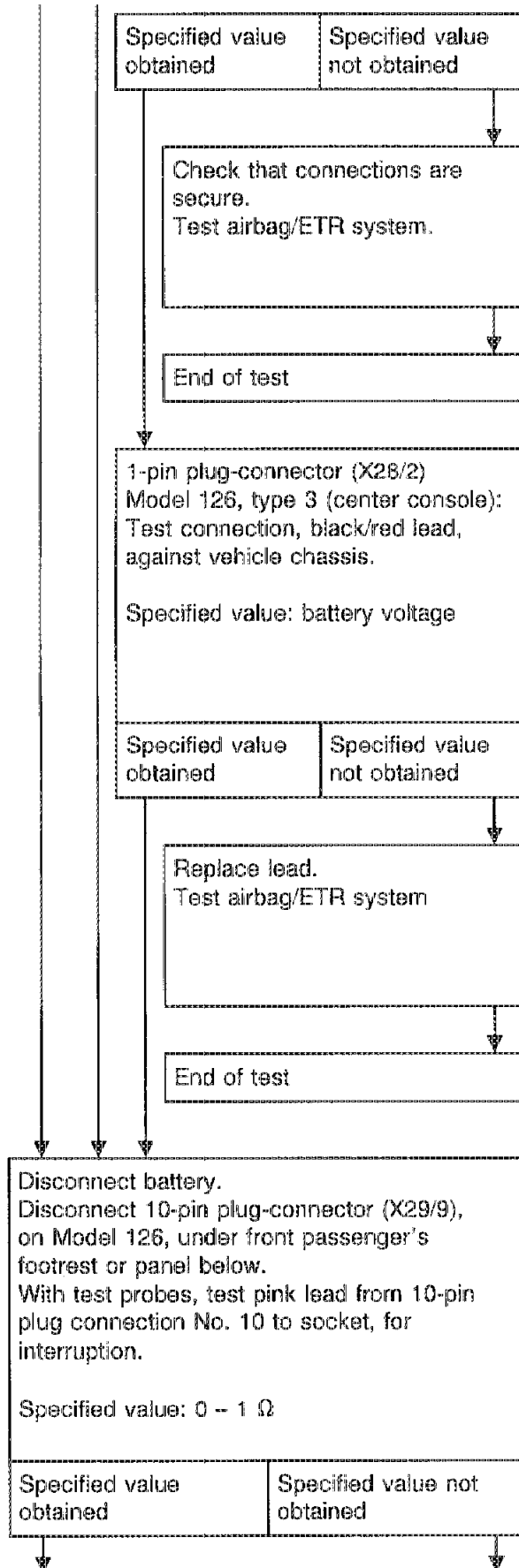

191-25830

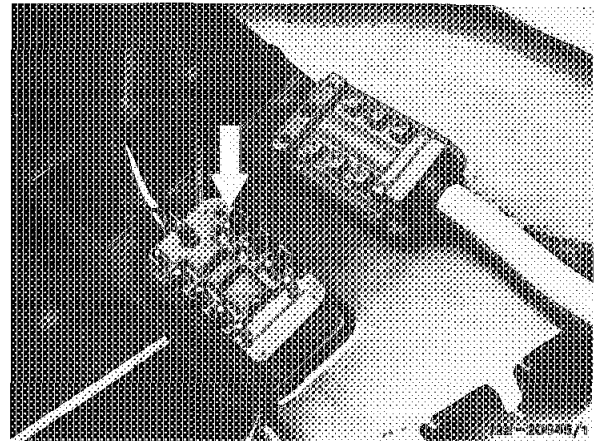
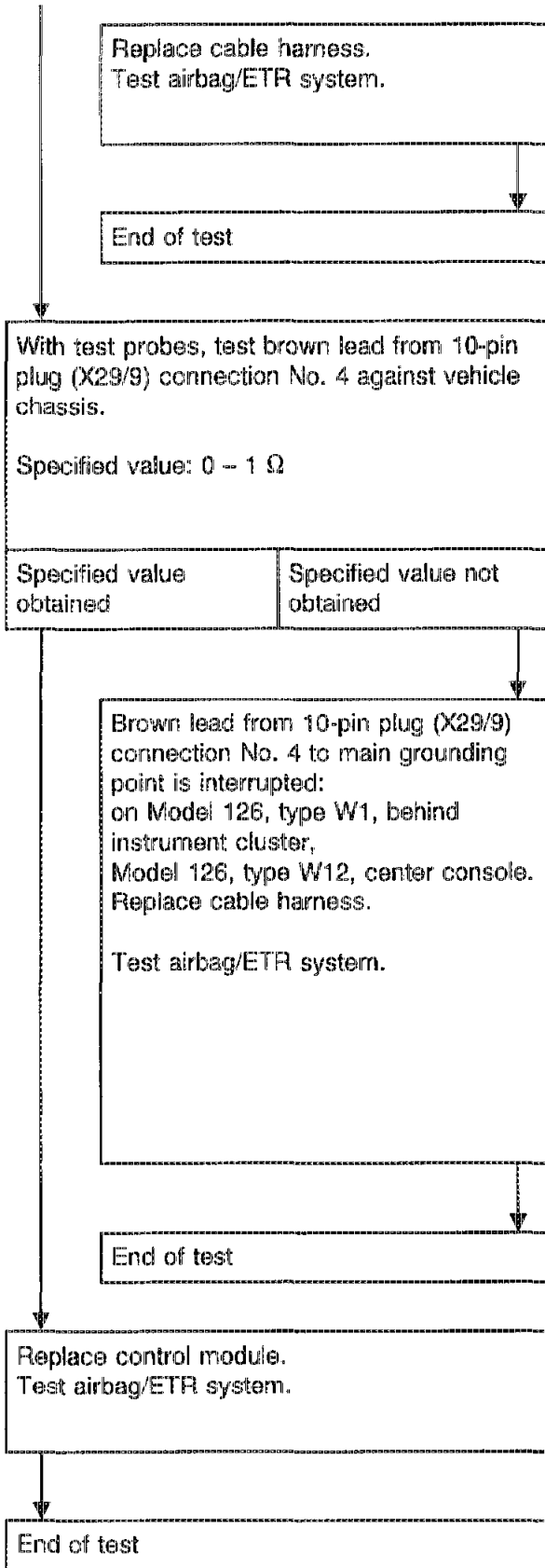

182-20645/1

91-700 Test program, airbags and ETR (up to 08/87)

If, after the ignition key has been turned to position 1, the control lamp does not light up or does not go out within approx. 10 seconds or flickers intermittently when the vehicle is being driven, proceed as follows.

Test airbag and ETR system

Test stage 1 (test selector switch in position 1)
Test power supply to control module (battery OK).
Connect test instrument to 10-pin plug on cable harness (see "Connecting test instrument").
Turn ignition key to position 1.
Specified value: battery voltage

Specified value obtained

Specified value not obtained

Disconnect battery.
Model 126, type 1:
Remove fusebox.
Check black/red lead for secure attachment.
Model 126, type 1.
Check terminal 15R, fuse 7 input for secure attachment.

Disconnect test instrument from 10-pin plug on cable harness.
Connect test instrument for external resistance testing.
Set test selector switch to position 9.

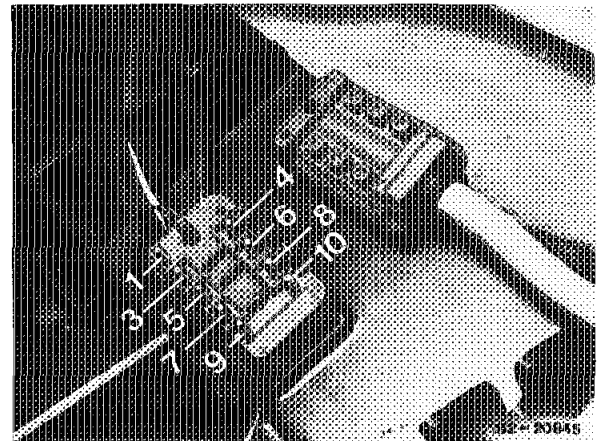
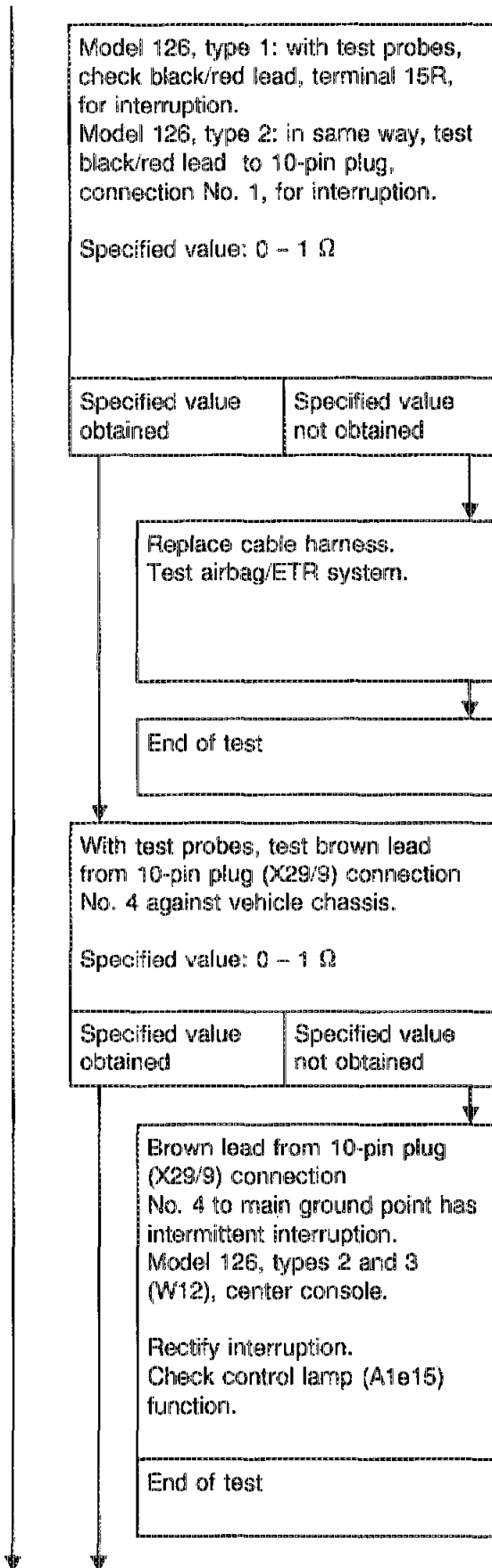

182-20645

91-700 Test program, airbags and ETR (up to 08/87)

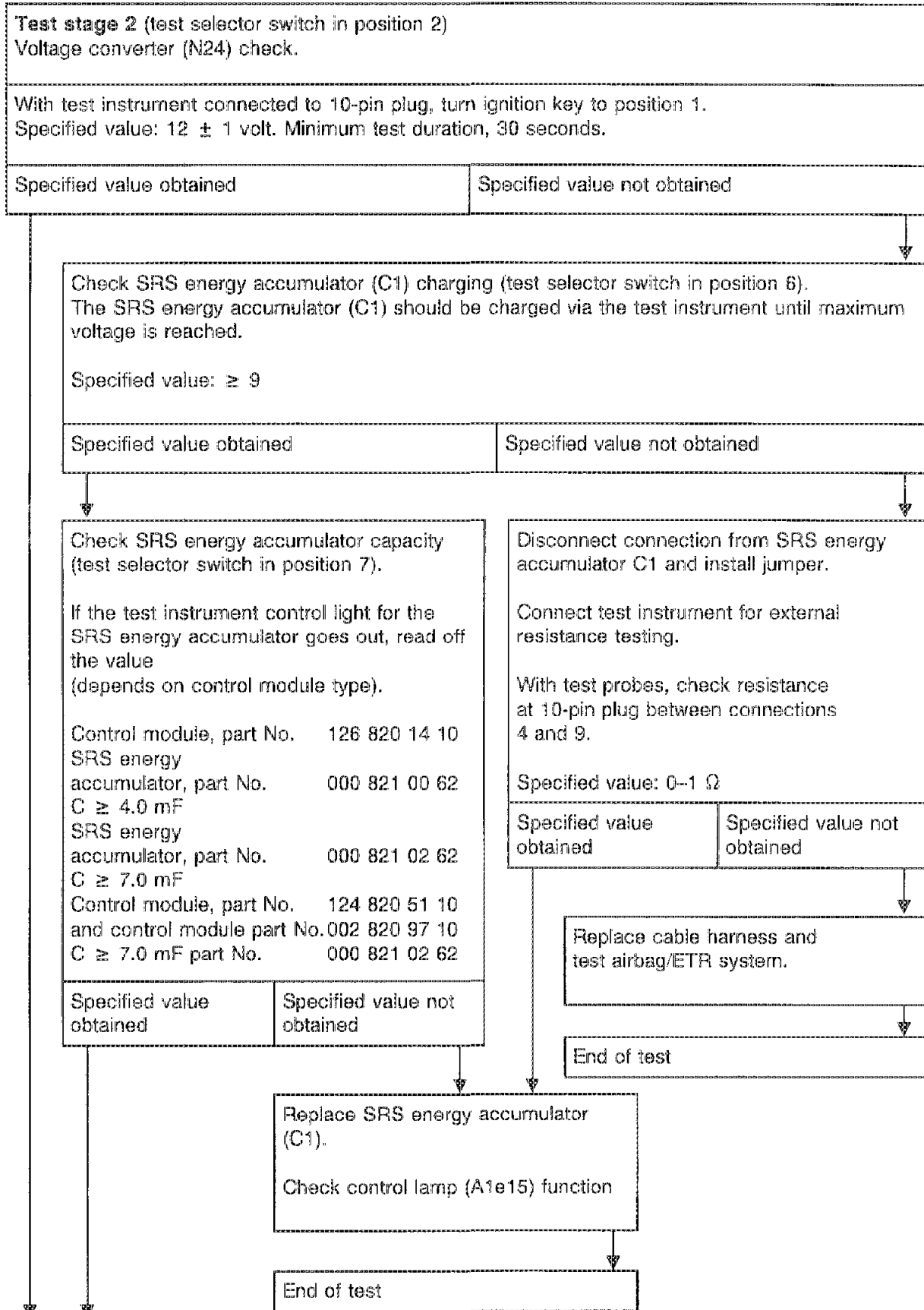

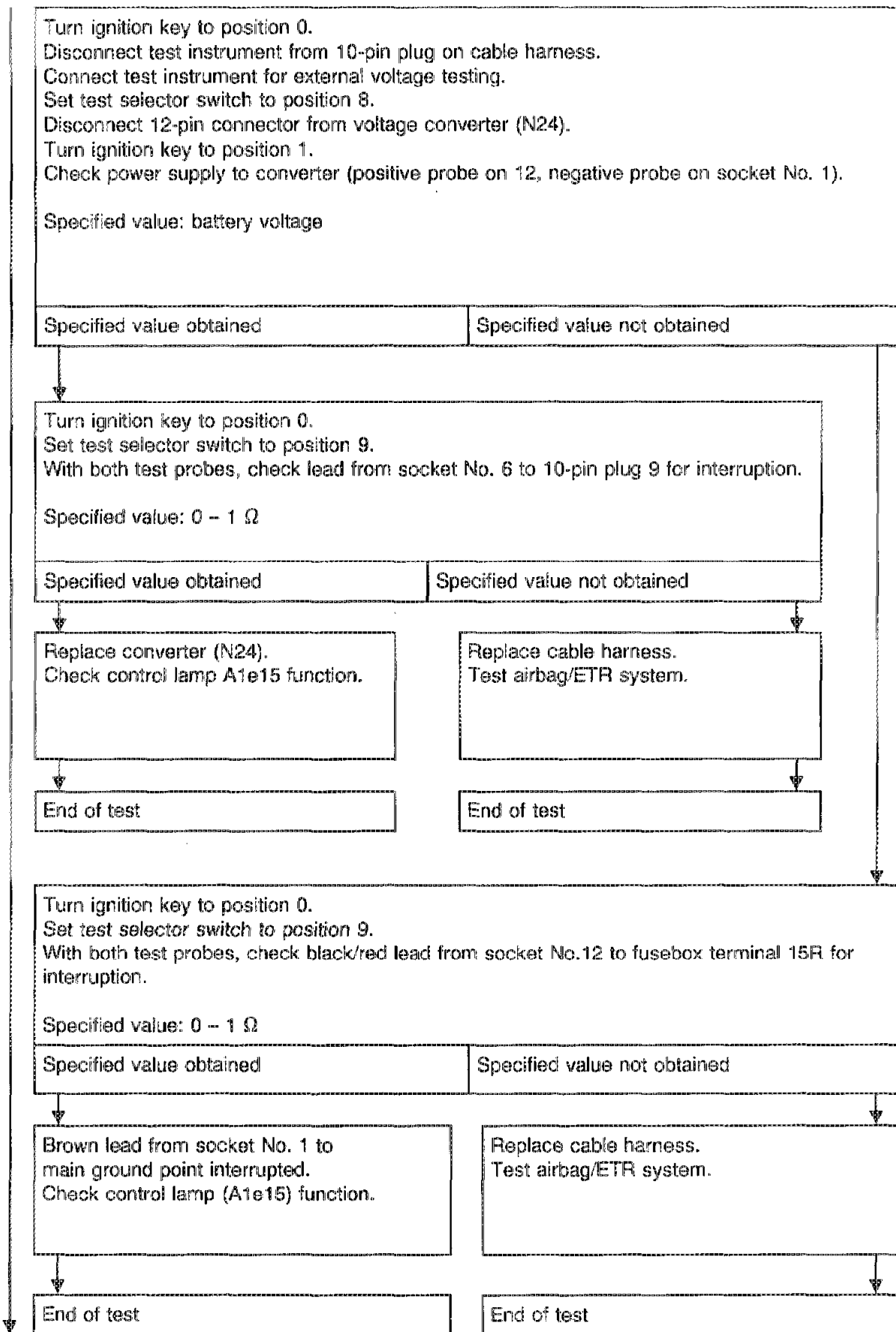

Test stage 3
 Check airbag squib (R12/3) resistance.

For this test, turn steering wheel several times to full lock, left and right.

With test instrument connected to 10-pin plug, turn ignition key to position 1.

Specified value: 2 – 10 Ω

Specified value obtained	Specified value not obtained
--------------------------	------------------------------

To test insulation resistance (cable harness on ground connection) press ground button (arrow).

Specified value: ≥ 20 kΩ (EEE)

Specified value obtained	Specified value not obtained
--------------------------	------------------------------

Replace cable harness.
 Test airbag/ETR system.

End of test

Disconnect 2-pin plug connector (X28/4) under left side of instrument panel (to do this, disconnect and reconnect battery).

Resistance: ≥ 20 kΩ EEE (∞)
 If value is less, replace cable harness, test airbag/ETR system.
 If value is ≥ 20 kΩ EEE (∞), bridge 2-pin plug, read off resistance.

Specified value: 0 – 1 Ω

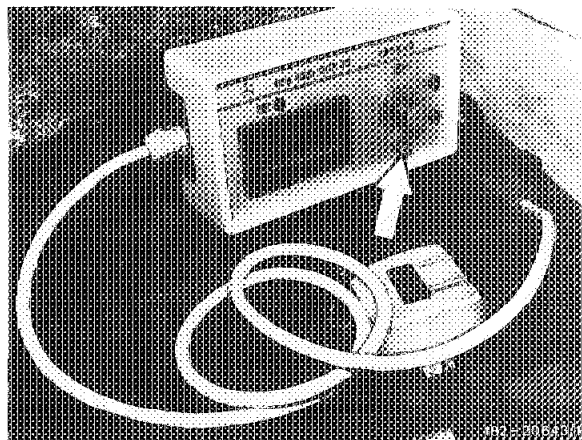

182-20643/1

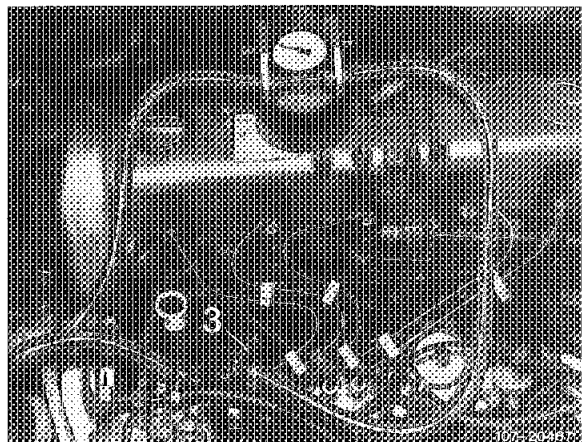

107-20467

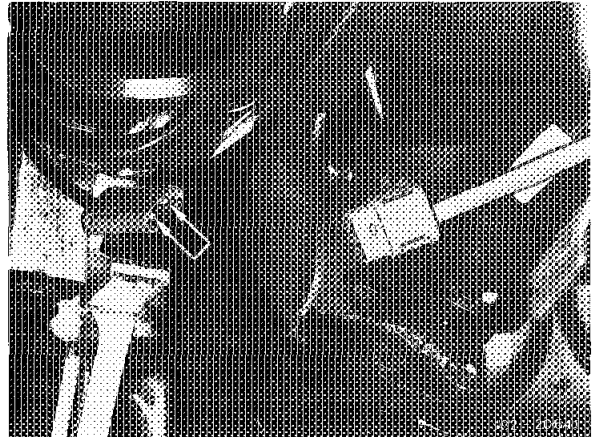
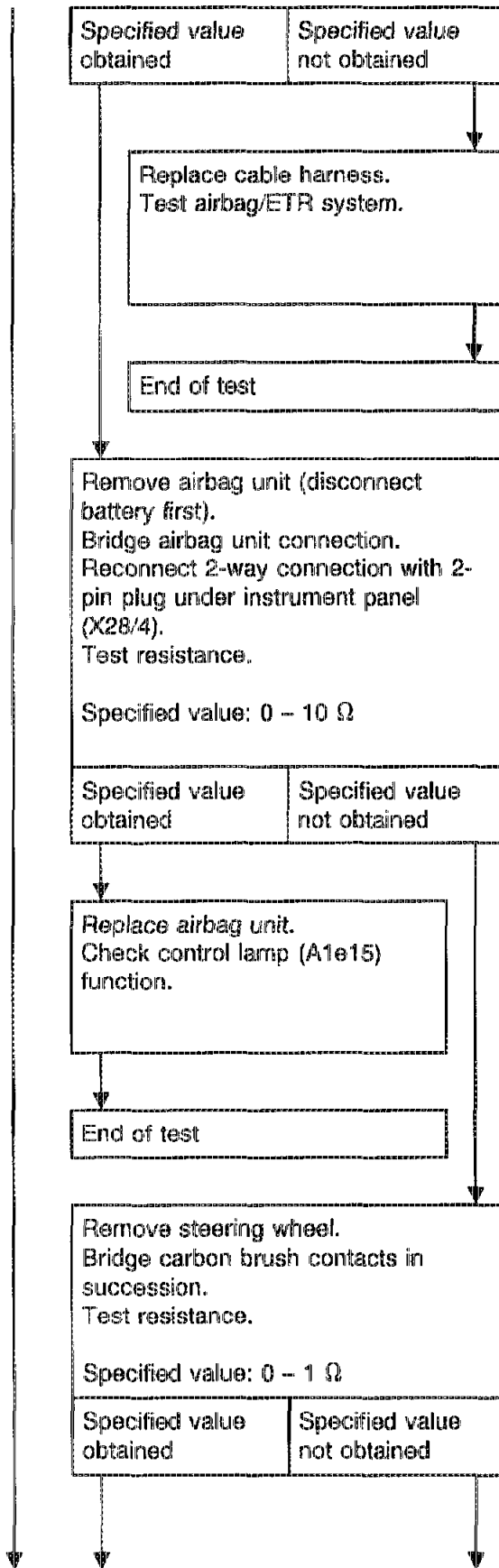

182-20641



182-20673

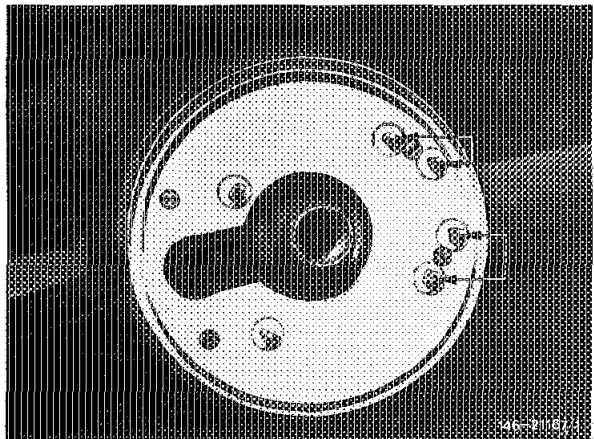

146-21167/1

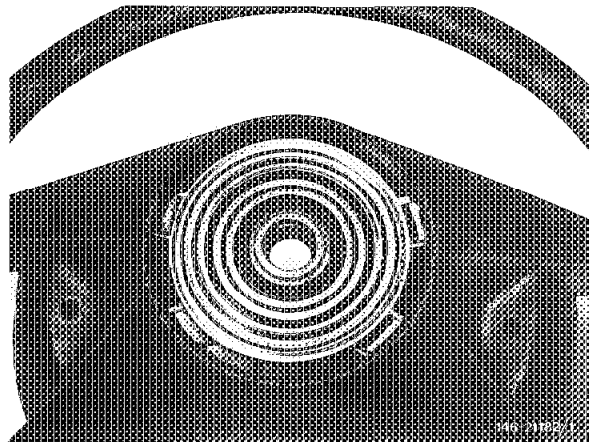
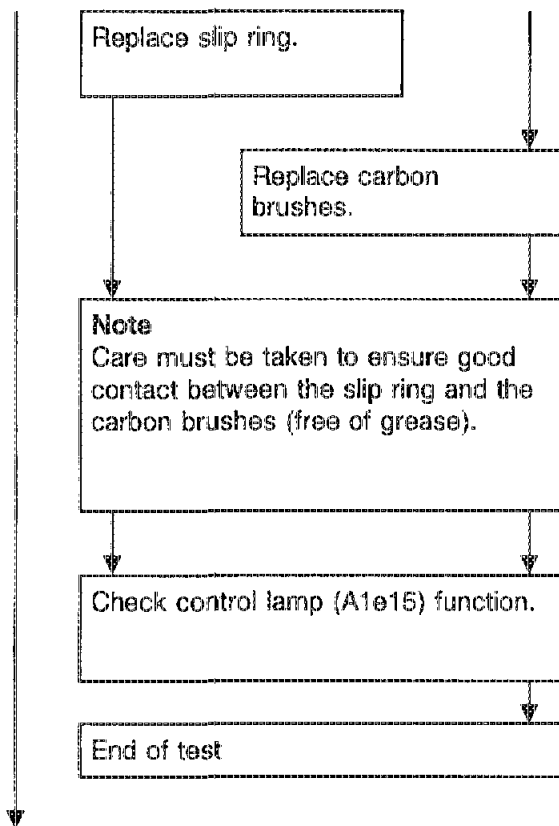

146-21182/1

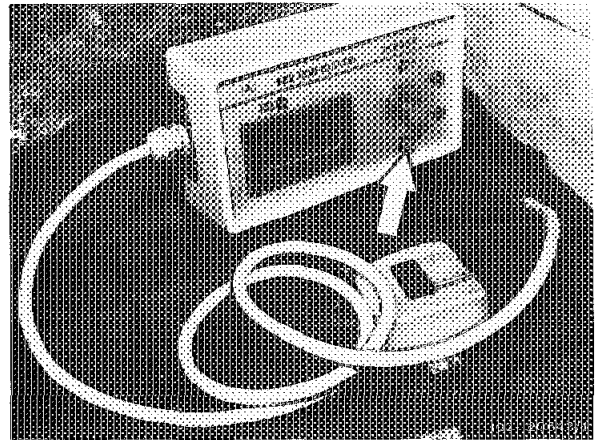
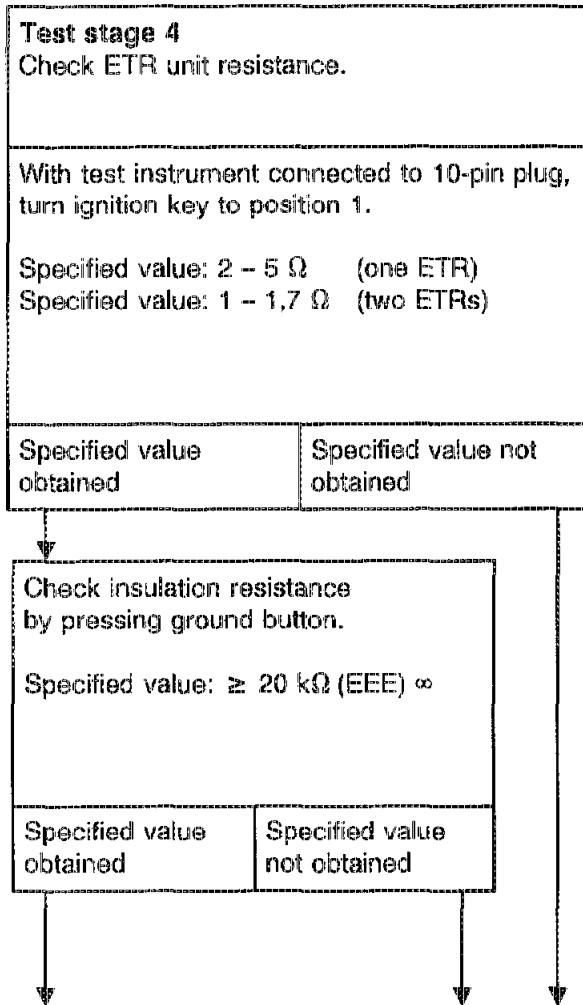

182-20643/1

Replace cable harness.
Test airbag/ETR system.

End of test

Remove safety belt trim, right side.
Disconnect ETR unit.
Resistance: $\geq 20 \text{ k}\Omega \text{ EEE}(\infty)$.
If value is less, replace cable harness,
test airbag/ETR system.
If value is $\geq 20 \text{ k}\Omega \text{ EEE}(\infty)$ bridge
connection.
Check resistance.

Specified value: $0 - 1 \Omega$

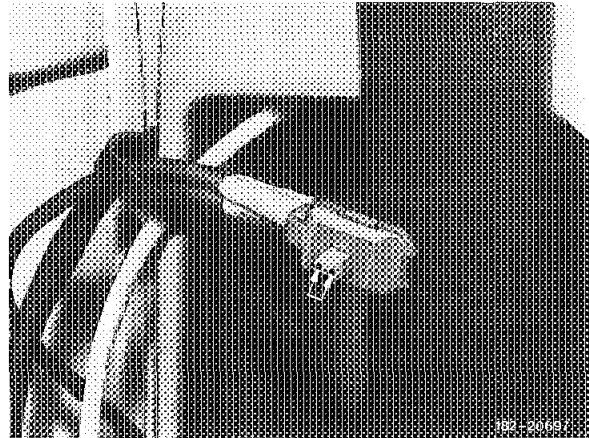

182-20897

Specified value obtained	Specified value not obtained
-----------------------------	---------------------------------

Replace ETR unit.

Replace cable
harness.

Test airbag/ETR system.

End of test

Test stage 5 is omitted.



Test stage 6
 Check SRS energy accumulator (C1) charge.

The SRS energy accumulator (C1, capacitor) should be charged via the test instrument until maximum voltage is reached.

Specified value: ≥ 9

Specified value obtained	Specified value not obtained
--------------------------	------------------------------

Disconnect connection from SRS energy accumulator (C1).
 Bridge connection.
 Connect test instrument for external resistance testing.
 With test probes, check resistance at 10-pin plug between connections Nos. 4 and 9.

Specified value: $0 - 1 \Omega$

Specified value obtained	Specified value not obtained
--------------------------	------------------------------

Replace cable harness.
 Test airbag/ETR system.

End of test

Replace SRS energy accumulator (C1) and repeat test stage 6.

Specified value obtained	Specified value not obtained
--------------------------	------------------------------

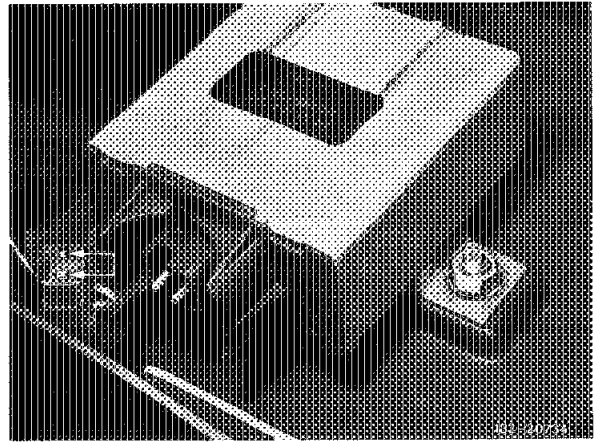

182-20734

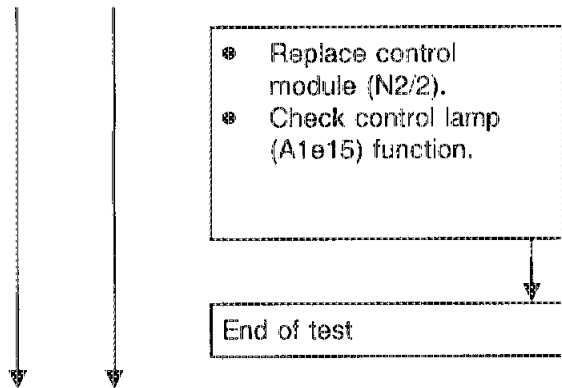

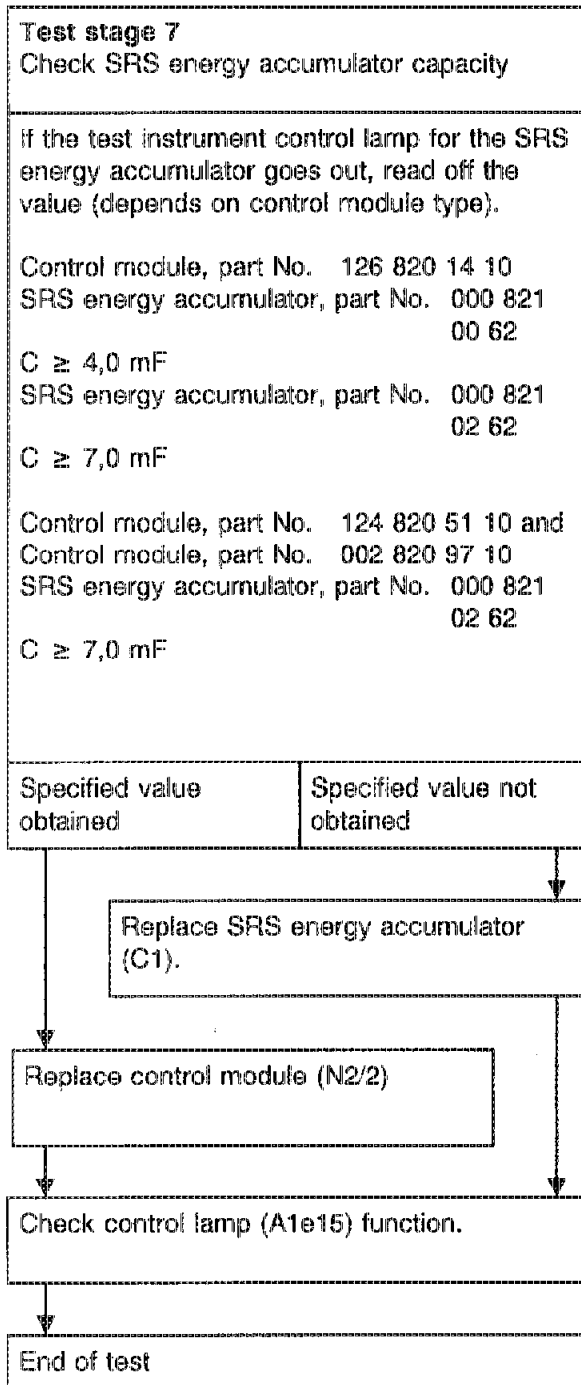

Test directions for test instrument 126 589 10 21 00

(revised version)

Before making tests with the test instrument, check the airbag restraint system with the RS control lamp (A1e15). With ignition switched on, the RS control lamp should glow for approx. 10 seconds. If necessary, check control lamp or lead.

⚠ CAUTION!

Before disconnecting the red 10-pin plug (X29/9) in order to connect the test instrument, always turn the ignition key to position 0 and disconnect and insulate the negative battery terminal. Then reconnect the battery for the tests.

Test stage	Scope of test	Operation	Specified value	Possible causes of deviation from specified value
1	Power supply	Ignition: OFF Disconnect 10-pin plug (X29/9) and connect plug on cable harness to test instrument Ignition: ON	LED: ☒ ON Battery voltage	Cable harness faulty.
2	Voltage converter N24 (not fitted to all vehicles)	Ignition: ON	LED: ☒ ON U = 12 ± 1 V after 30 s	Voltage converter faulty. SRS energy accumulator faulty. Cable harness faulty.
3	Airbag unit resistance (R12/3). Slip ring	Ignition: ON Turn steering wheel to full lock (left and right)	LED: ☒ ON R = 2 - 10 Ω	Faulty contact between slip ring and carbon brush. Lead faulty. Driver's airbag unit faulty.
	Insulation resistance	Ignition: ON Press ... key	LED: ☒ ON R ≥ 20 kΩ-EEE (EEE = ∞)	Cable harness faulty. Airbag unit faulty.

91-700 Test program, airbags and ETR (up to 08/87)

4	ETR resistance Right front ETR squib (R12) Front ETR squibs (R12/1 and R12/2)	Ignition: ON	LED: E3 ON R = 2 - 5 Ω (Parallel connection) R = 1 - 1.7 Ω	Lead faulty. ETR unit faulty. Lead faulty. ETR unit faulty.
	Insulation resistance	Ignition: ON Press ┐ key	LED: E3 ON R ≥ 20 kΩ-EEE (EEE = ∞)	Cable harness faulty. Airbag unit faulty.
5	Omitted			
6	SRS energy accumulator (C1) Charging test	Ignition: ON	LED: E3 ON ON Specified value > 9	Lead faulty. SRS energy accumulator faulty.
7	SRS energy accumulator (C1) capacity test	Ignition: ON	LED E3 ON ON goes out Now read off value C ≥ 4.0 mF C ≥ 7.0 mF	SRS energy accumulator faulty.
	Observe component assignments	Control module part No.	SRS energy accumulator capacity	SRS energy accumulator part No.
		126 820 14 10	4.0 mF	000 821 00 62
			7.0 mF	000 821 02 62
		002 820 97 10	7.0 mF	000 821 02 62
		124 820 51 10	7.0 mF	000 821 02 62

91-700 Test program, airbags and ETR (up to 08/87)

Additional uses for the test instrument as a voltmeter/ohmmeter (in connection with airbag testing only):

8 Volt- meter (volts)	Voltage testing	External power supply lead on 12V battery	LED: ☐ ON U = 0 – 99.9 V	
9 Ohm- meter Ω	Resistance testing		LED: ☐ ON R = 0 – 99.9 Ω	
10 Ohm- meter (kΩ)	Not possible with test instrument 126 589 10 21 00. If necessary, use only approved digital multimeter (e.g. Sun, DMM 5, Avometer).			