

82-0860 Electrical seat adjustment front

A. Version without Memory function (position storage)

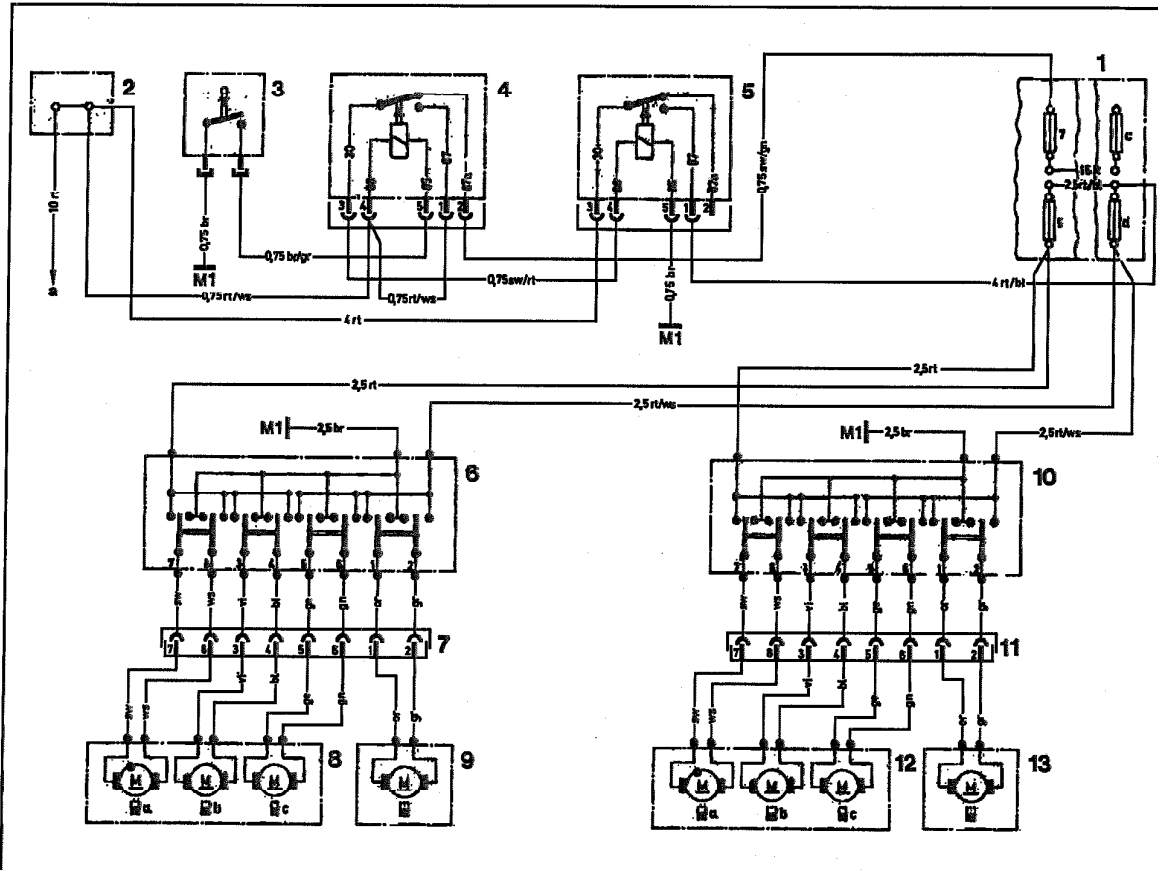

P82-0385-57

Wiring diagram 1981

- | | | | |
|---|---|----|--|
| 1 | Fuse holder | 10 | Switch seat adjustment (front passenger) |
| 2 | Soldering point terminal 30 (fuse box) | 11 | 8-conductor connector |
| 3 | Door contact switch window lifter/seat adjustment | 12 | Motor group seat (front passenger) |
| 4 | Relay window lifter/seat adjustment (comfort circuit) | a | Seat height front |
| 5 | Relay window lifter/seat adjustment (main relay) | b | Seat forward/backward |
| 6 | Switch seat adjustment (driver) | c | Seat height rear |
| 7 | 8-conductor connector | 13 | Motor backrest (front passenger) |
| 8 | Motor group seat (driver) | a | Terminal block motor cable harness |
| a | Seat height front | M1 | Main ground (behind instrument cluster) |
| b | Seat forward/backward | | |
| c | Seat height rear | | |
| 9 | Motor backrest (driver) | | |

82-0860 Electrical seat adjustment front

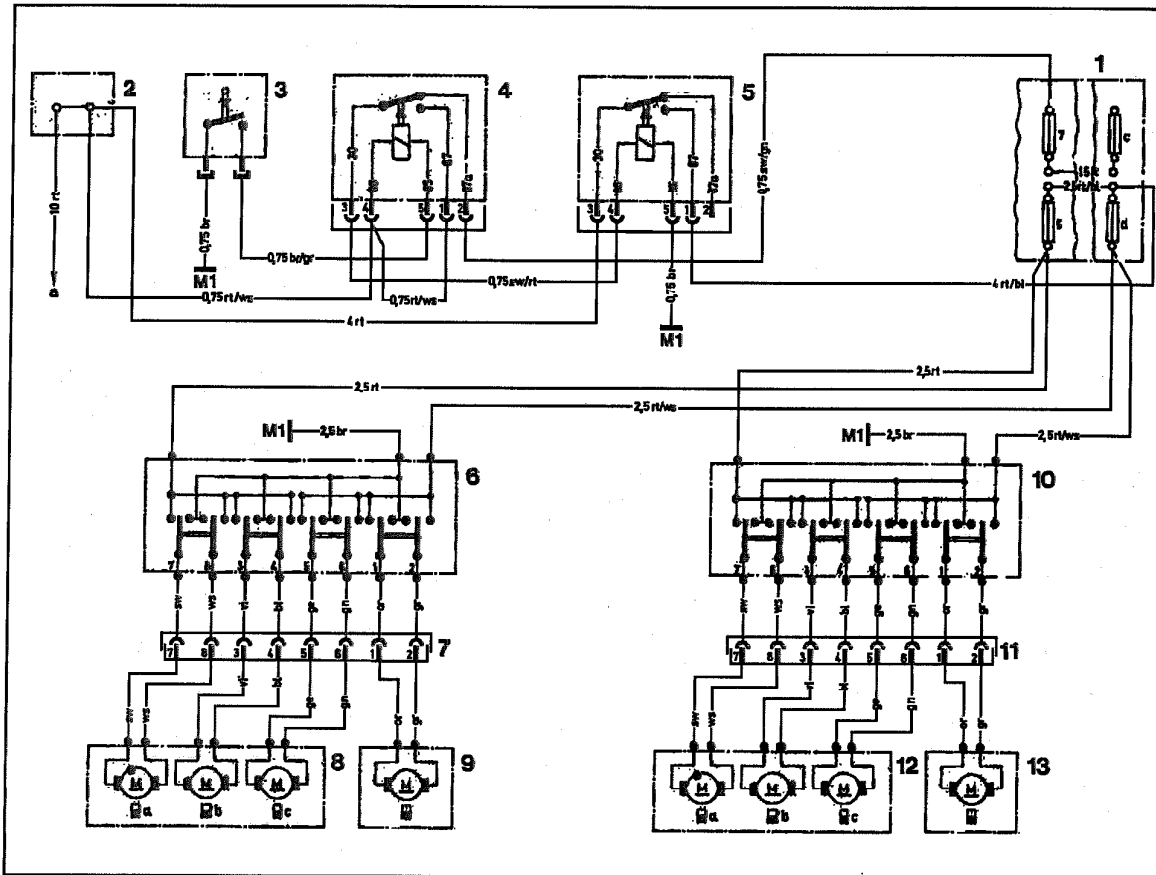

P82-0385-57

Wiring diagram 1982/83

1	Fuse holder	10	Switch seat adjustment (front passenger)
2	Soldering point terminal 30 (fuse box)	11	8-conductor connector
3	Door contact switch window lifter/seat adjustment	12	Motor group seat (front passenger)
4	Relay window lifter/seat adjustment (comfort circuit)	a	Seat height front
5	Relay window lifter/seat adjustment (main relay)	b	Seat forward/backward
6	Switch seat adjustment (driver)	c	Seat height rear
7	8-conductor connector	13	Motor backrest (front passenger)
8	Motor group seat (driver)	a	Terminal block motor cable harness
a	Seat height front	M1	Main ground (behind instrument cluster)
b	Seat forward/backward		
c	Seat height rear		
9	Motor backrest (driver)		

82-0860 Electrical seat adjustment front

Function

Seat adjustment is effected by means of a switch combination arranged in the door trim panel.

Note

The wiring set is permanently connected to the switch.

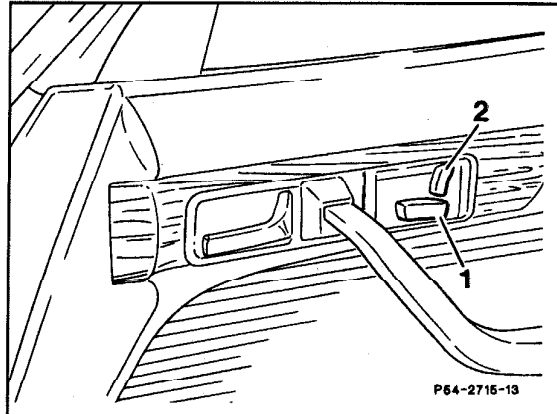

P64-2715-13

P54-2715-13

Adjustability with switch (1):

- Seat forward/backward
- Seat height front
- Seat height rear

Adjustability with switch (2):

- Backrest - forward and backward

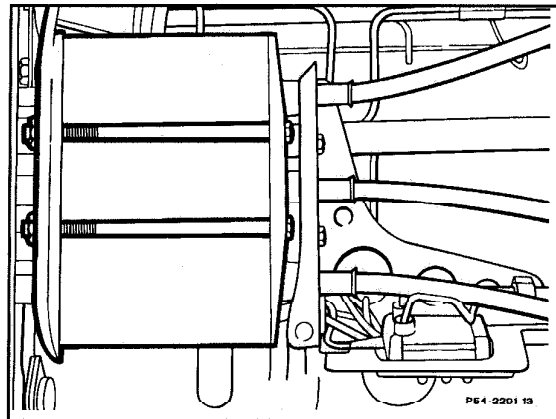

P64-2201-13

P54-2291-13

A group of three motors is arranged in the frame of the seat surface for longitudinal and vertical adjustment.

The motors drive a gearing (1) via three shafts in this way effecting the adjustment.

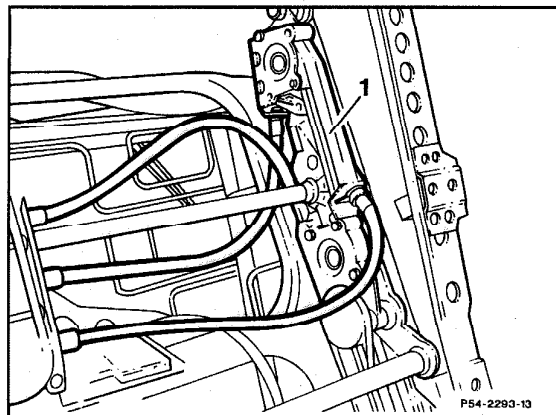

P54-2293-13

P54-2293-13

82-0860 Electrical seat adjustment front

An additional motor is provided in the backrest frame which serves to adjust the backrest forward and backward via a gearing.

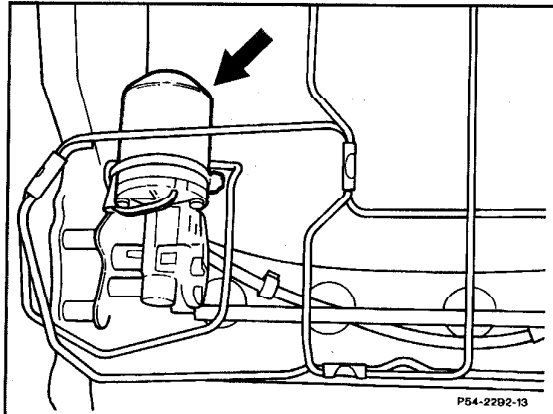

P54-2292-13

The 8-pole plug for the motors is located at the bottom on the seat frame.

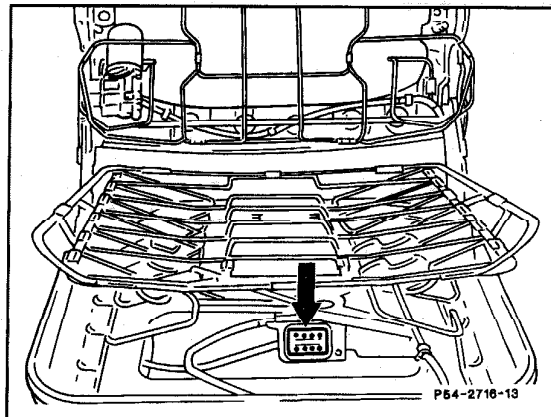

P54-2716-13

Switch seat and head restraint adjustment

- 15 Switch
- d Head restraint up/down
- e Seat height front
- f Seat forward/backward
- g Seat height rear
- h Backrest

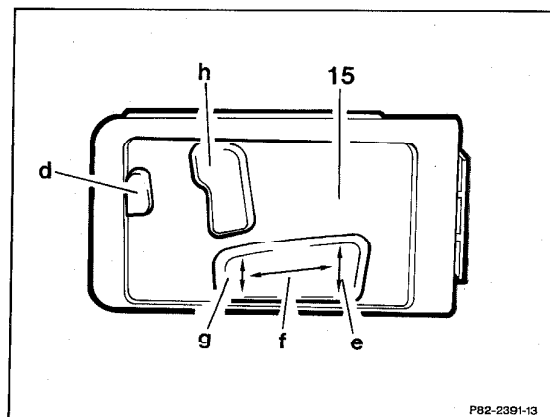

P82-2391-13

82-0860 Electrical seat adjustment front

Note

The wiring set is connected with the switch by means of three connectors.

The switch can be removed without dismantling the door trim panel.

Adjusting motor head restraint

The adjusting motor for the head restraint is attached to the backrest frame.

The head restraint is adjusted by means of a rack driven by a motor via a shaft.

B. Version with Memory function (position storage)

Operation

By means of a switch in the door trim panel it is possible to actuate the seat and head restraint adjustment with key positions 1 and 2 or with opened driver's door.

Two seat and applicable head restraint positions can be stored and called up as required.

Note

The cable harness is connected with the switch by means of four connectors.

Switch seat and head restraint adjustment

- 15 Switch
- a Position key 1
- b Position key 2
- c Storage key
- d Head restraint up/down
- e Seat height front
- f Seat forward/backward
- g Seat height rear
- h Backrest

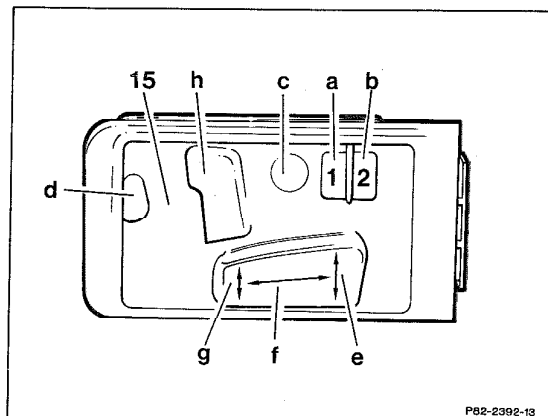

P82-2392-13

Storing the seat and head restraint positions

- 1 Position the seat and the head restraint as required.
- 2 Press storage key (C).
- 3 Press position key 1 or 2.

The position key must be pressed within 3 seconds after the storage key (C), otherwise position will not be stored in memory.

82-0860 Electrical seat adjustment front

Calling up stored position (seat and head restraint)

4 Press position keys 1 or 2.

For safety reasons the position key must be pressed until the end position has been reached and all motors have stopped turning.

If several keys are actuated simultaneously, the adjusting process will be interrupted. A stored position can be reached only after renewed pressing of a position key.

Adjusting device

The seat is adjusted by a gearing (18) driven by 3 motors (10, 11, 12) via 3 shafts (19). These parts are arranged below the seat.

One potentiometer (12a) each is allocated to the motors as position sensor for the storage. Depending on the seat position the potentiometer directs a certain resistance value to the electronic control module where it is stored.

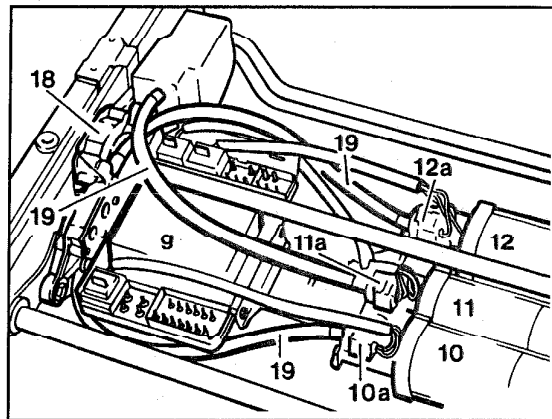

P82-2393-13

If a potentiometer for example on the motor for the longitudinal adjustment is defective, the longitudinal adjustment can no longer be stored. The adjustment will not be impaired by this.

Motors, shafts, potentiometers and the gearing for the seat adjustment are individually exchangeable.

The backrest is adjusted by a motor with integrated potentiometer and gearing. The motor is attached to the backrest frame.

The adjusting motor for the head restraint is attached to the backrest frame.

The head restraint is adjusted by a rack driven by a motor via a shaft. An exchangeable potentiometer is attached to the motor as position sensor.

Electronic control module

The electronic control module (9) is attached below the seat.

If the voltage supply to the control module is interrupted for more than 1.5 hours (e.g. with battery disconnected), the storage is deleted. The seat and head restraint positions must be newly stored in the memory.

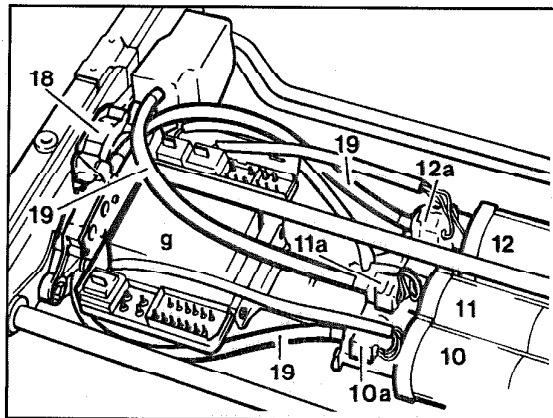

P82-2393-13

b) Seat and backrest adjustment
Seat left

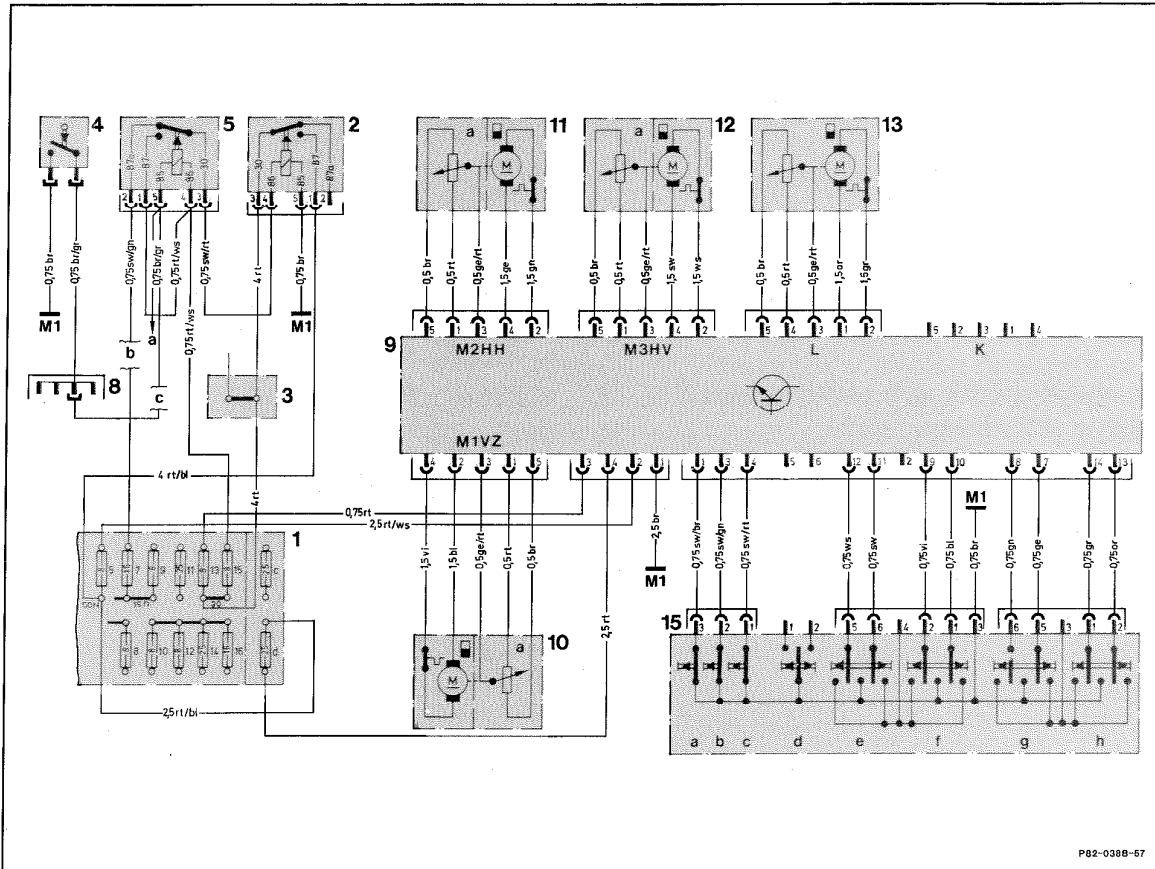

P82-0388-57

P82-0388-57

Wiring diagram 1984

- | | | | |
|----|---|----|---|
| 1 | Fuse holder | 15 | Switch seat adjustment |
| 2 | Relay seat adjustment (main relay) | a | Position key 1 |
| 3 | Terminal block terminal 30 (fuse box) | b | Position key 2 |
| 4 | Door contact switch seat adjustment | c | Storage key |
| 5 | Relay seat adjustment (comfort circuit) | d | Head restraint up/down |
| 8 | Terminal block door contact switch | e | Seat height front |
| 9 | Control module seat adjustment | f | Seat forward/backward |
| 10 | Motor seat forward/backward M1VZ | g | Seat height rear |
| 11 | Motor seat height rear M2HH | h | Backrest |
| 12 | Motor seat height front M3HV | M1 | Main ground (behind instrument cluster) |
| 13 | Motor backrest L | a | Dome lamp |
| | | b | Wire is looped via window lifter relay |
| | | c | Wire is looped via lacing of backrest lock and the warning unit (seat belt, light and ignition) |

Seat right

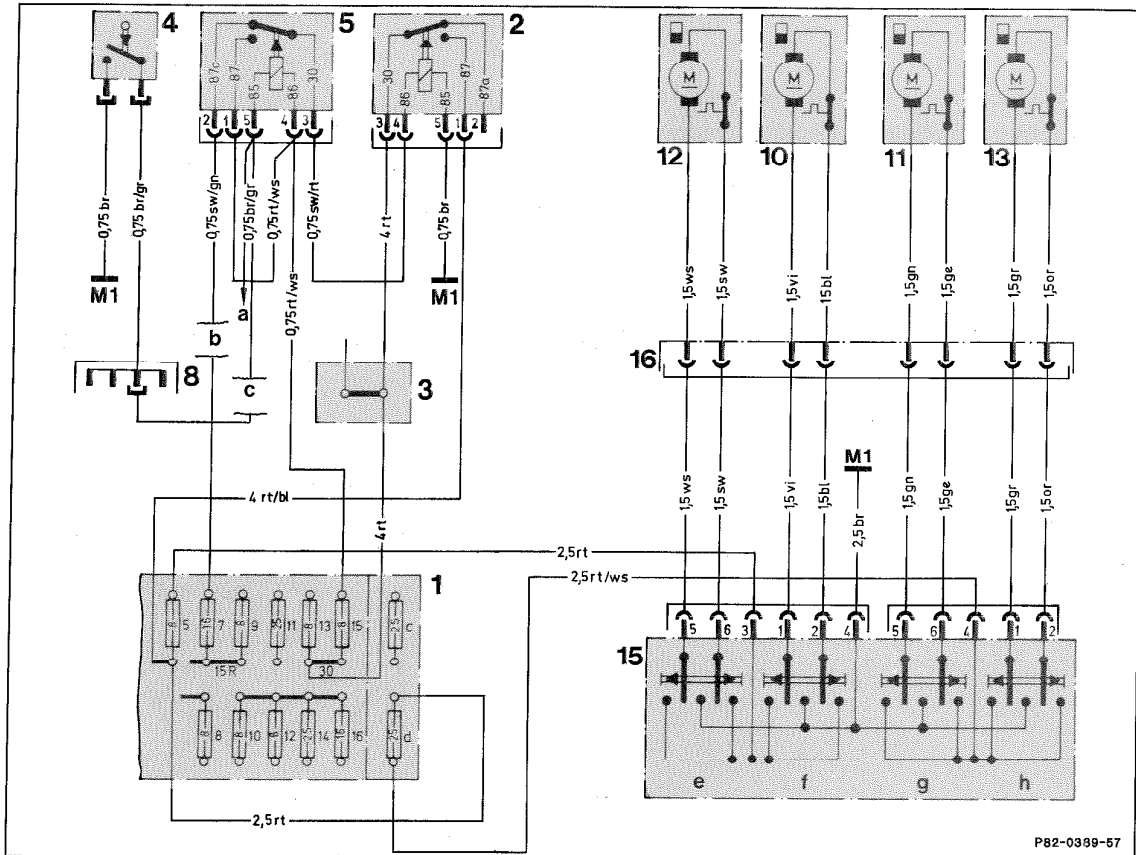

P82-0389-57

P82-0389-57

Wiring diagram 1984

- | | | | |
|----|---|----|---|
| 1 | Fuse holder | 15 | Switch seat adjustment |
| 2 | Relay seat adjustment (main relay) | e | Seat height front |
| 3 | Terminal block terminal 30 (fuse box) | f | Seat forward/backward |
| 4 | Door contact switch seat adjustment | g | Seat height rear |
| 5 | Relay seat adjustment (comfort circuit) | h | Backrest |
| 8 | Terminal block door contact switch | 16 | Connector 8-pole (below seat) |
| 10 | Motor seat forward/backward | M1 | Main ground (behind instrument cluster) |
| 11 | Motor seat height rear | a | Dome lamp |
| 12 | Motor seat height front | b | Wire is looped via window lifter relay |
| 13 | Motor backrest | c | Wire is looped via lacing of backrest lock and via warning device (seat belt, light and ignition) |