

# 40-400 Checking collision-damaged vehicles

## Checking wheelbase and comparison measurements on front and rear axle

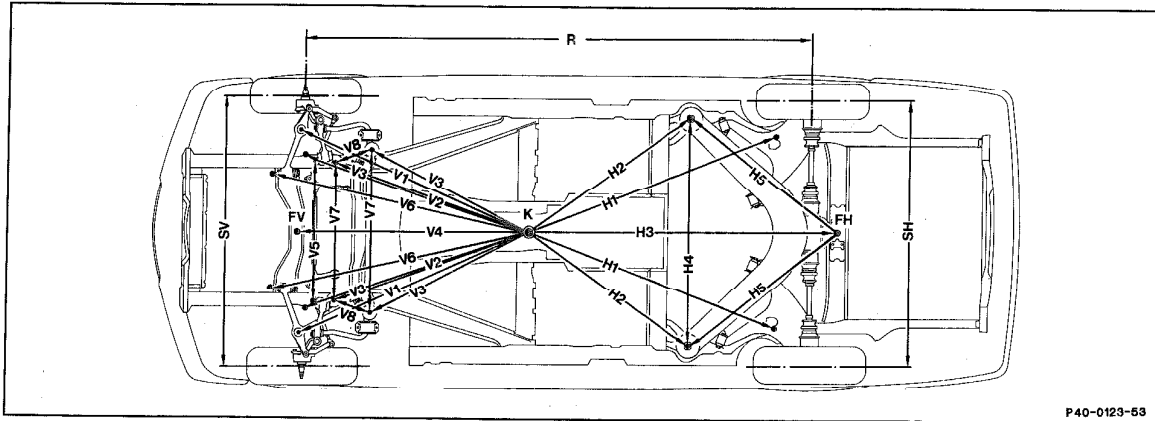

P40-0123-53

Model 126 through 07/85

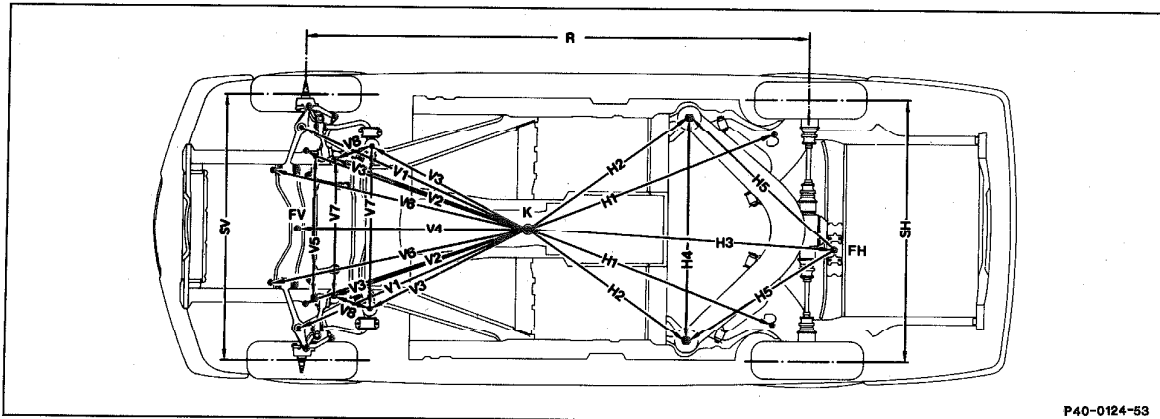

P40-0124-53

Model 126.04 starting 08/85

R	Wheel base	FV	Locating bore in fame cross member for front axle
SV	Track on front axle	FH	Locating bore in rubber mount of rear axle
SH	Track on rear axle		
K	Check bore in frame floor		

## 40-400 Checking collision-damaged vehicles

### Checking axle base and comparison measurements on front and rear axle

Checkup of vehicles involved in an accident or suspected to have been involved in an accident

#### Data

Measured	Permissible deviation between left and right	Distance	Comment
	mm	mm	

#### Front axle

V1 From check bore "K" to bearing of braking force supporting arm on lower control arm	10	-	A prerequisite for evaluation of dimension "V 1" is that the values for caster and camber of the front wheels at left and right are within the permissible tolerances (40-320).
V2 From check bore "K" to front end of recess in frame side member	4	-	-
V3 From check bore "K" to front axle cross member mounts on frame side member	front 7	-	-
	rear 7		
V4 From check bore "K" to locating bore "FV" in frame cross member	-	1280 <sup>+2</sup> <sub>-6</sub>	-
V5 Distance of hex. screws for bushing of upper control arms on front end from left to right	-	829 <sup>+3</sup> <sub>-5</sub>	-
V6 Distance from check bore "K" to bushing of lower control arm on frame cross member	3.5	-	-
V7 Distance left to right between bushing of pivot carrier of braking force supporting arm and cross member	-	front 786 ± 3	-
	-	rear 930 ± 3	-
V8 Distance between front and rear bushing of pivot carrier of braking force supporting arm and cross member	-	220.1 ± 1,5	-

## 40-400 Checking collision-damaged vehicles

### Data

Measured	Permissible difference between left and right mm	Distance mm	Comment
----------	---	----------------	---------

### Rear axle

H1 From check bore "K" to outer hex. screw of lower suspension for shock absorber or spring strut on semi-trailing arm	4	-	During this measurement, the vehicle level on rear axle left and right should be as much as possible equal. Permissible difference of semi-trailing arm position between left and right is 3 mm. If required, load higher vehicle side with a weight in trunk or raise semi-trailing arm on lower side accordingly. The specified deviation for dimension "H 1" is permitted only if the toe-in is within the permissible tolerances.
H2 From check bore "K" to front bearing of rear axle on frame floor	2.5	-	-
H3 From check bore "K" to locating bore "FH" in rubber mount of rear bearing on frame floor (through 07/85)	-	1869.5 ± 5	Mod. 126.021/022/032/036/120
		2009.5 ± 5	Model 126.023/033/037
		1784.5 ± 5	Model 126.04
H3 From check bore "K" to locating bore "FH" in rubber mount of rear bearing on frame floor (starting 08/85)	-	1875 ± 5	Mod. 126.020/024/034/036/038
		2014.5 ± 5	Mod. 126.025/035/037/039/125
		1790 ± 5	Model 126.044/045/046
H4 Distance of front bearing of rear axle shaft on frame floor	-	1290 ± 2	-
H5 From locating bore "FH" to front bearing of rear axle on frame floor	4	146.5 ± 4	-

Special tools

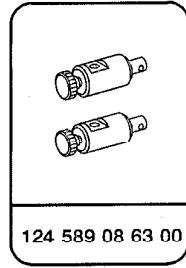
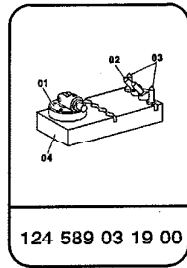
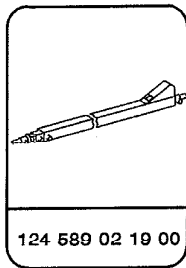
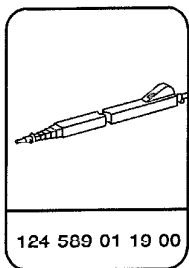

Note

The distance- and comparison measurements supplement the chassis measurements for vehicles following and suspected of an accident. For evaluation, always use difference between left and right or the distance.

The steel beam compasses (06) used up to now with a measuring length of 1500 – 2500 mm are provided with two measuring slides (06a and 06b), while one of the measuring slides is provided with a precision adjustment having an 1/10 mm vernier scale.

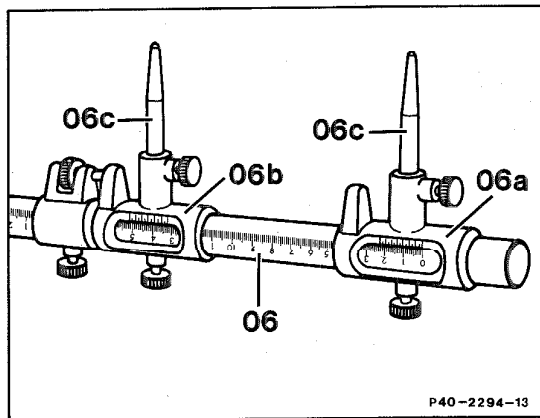

P40-2294-13

For diagonal measurements, always note value of distance measured at left and right and then find the difference. The slide without vernier need not be in 0 - position, but can be clamped down in a given position.

The steel beam compasses are replaced by two telescopic measuring bars, fabricated of light alloy:

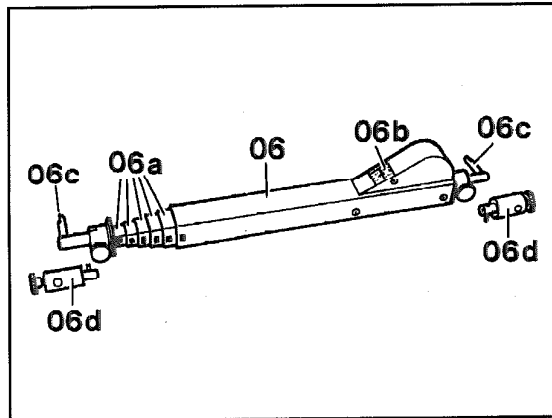

P40-2007-13

- a) Telescopic measuring bar 124 589 01 19 00, five elements with a measuring range from and up to 415 – 925 mm.

- 06 Telescopic measuring bar (base element)
- 06a Telescope
- 06b Measuring slide with vernier scale
- 06c Measuring tips for body-interior panels (in passenger compartment)
- 06d Connecting elements for attachment of measuring bolts

## 40-400 Checking collision-damaged vehicles

b) Telescopic measuring bar 124 589 02 19 00, three elements with a measuring range from and up to 920-2600 mm.

- 06 Telescopic measuring bar (base element)
- 06a Telescope
- 06c Measuring tips for body-passenger compartment panels
- 06d Connecting elements for attachment of measuring bolts

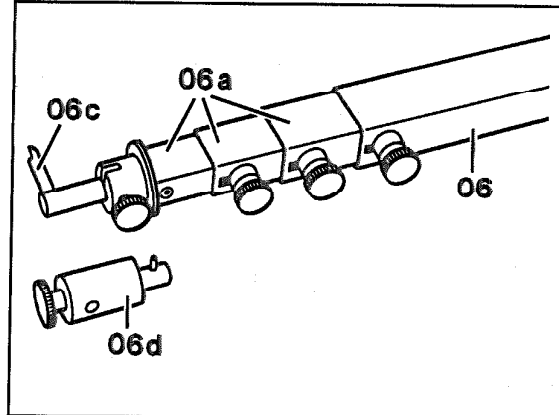

P40-2005-13

For measuring panels in passenger compartment use measuring tips (06c) 124 589 03 19 00 which are included in the set containing telescopic measuring bars.

For distance and comparison measurements the measuring tips (06c) are replaced by the connecting elements for attachment of measuring bolts (06d) 124 589 08 63 00 which is inserted in the telescopic measuring bar (06). The value determined can be read on the measuring slide (06b).

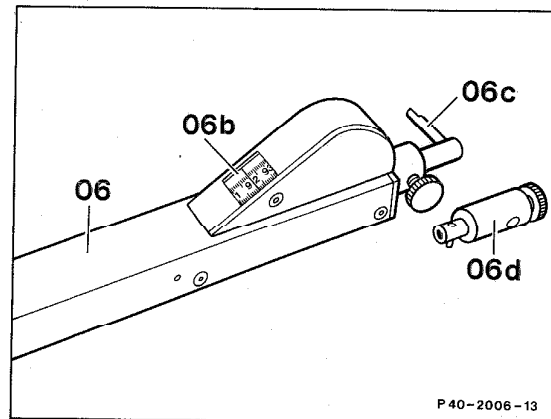

P 40-2006-13

P40-2006-13

## 40-400 Checking collision-damaged vehicles

Individual measurements on chassis require different inserts which are contained in the measuring set 116 589 11 63 00.

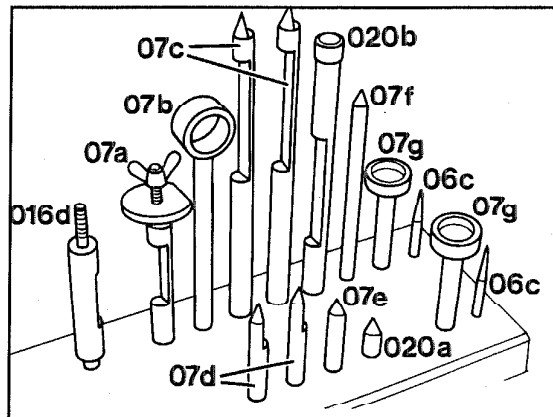

P40-2295-13

- 06c Measuring points, length 100 mm
- 07 Measuring set for beam compass and telescopic measuring bar
- 07a Retaining bolt with washer and wing nut
- 07b Measuring bolt with ring, length 167 mm
- 07c Measuring bolt with point, length 237 mm
- 07d measuring bolt with point, length 82 mm
- 07e Measuring bolt with point, length 60 mm
- 07f Measuring bolt with point, length 163 mm
- 07g Measuring bolt with disk, length 77 mm
- 016d Rear attachment of checking device for the bearing of front axle on frame floor (model 116 only)
- 020 Measuring set (additional parts)
- 020a Measuring bolt with point, length 25 mm
- 020b Measuring bolt with disk, length 217 mm

For measuring distance "H3" use measuring bolt (024h) contained in measuring set 123 589 06 63 00.

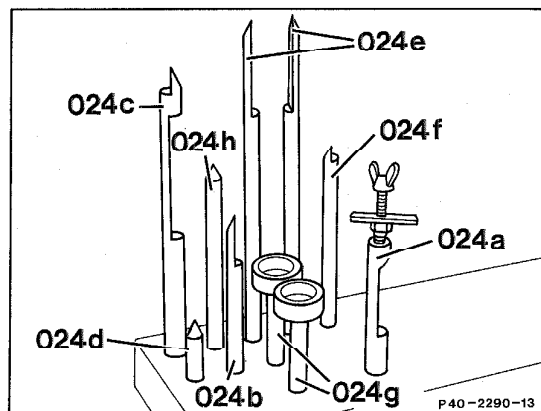

P40-2290-13

P40-2290-13

## 40-400 Checking collision-damaged vehicles

### CAUTION!

For the additional measurements "V7" and "V8" on bearing carrier use the two standard measuring tips (06c) of beam compass.

For measurements "V6" for bearing of lower control arm on frame cross member, modify previously used measuring bolt with point, length 152 mm (024f).

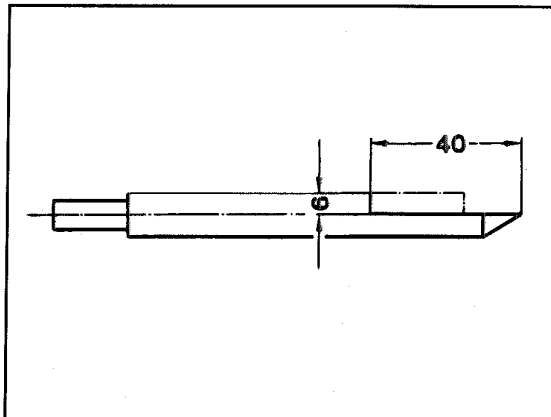

P40-0128-13

### Checking

1 Insert holding pin (024a) for beam compass or telescoping measuring bar into check bore "K" in frame floor and fasten with wing nut.

K Check bore in frame floor

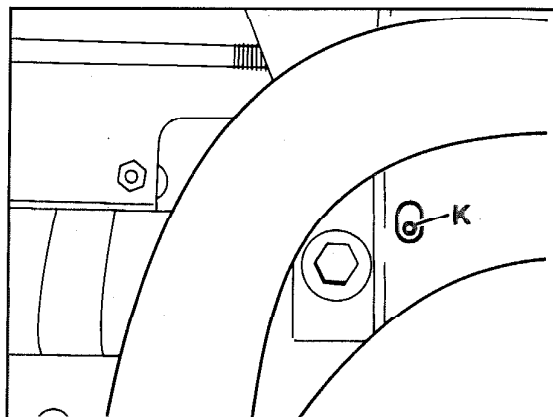

P40-2309-13

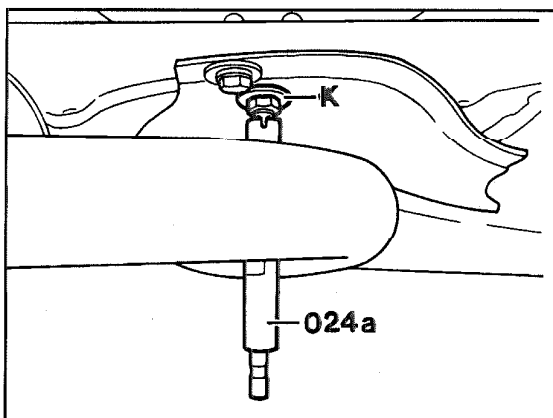

024a Holding bolt with washer and wing nut  
K Check bore in frame floor

P40-2311-13

**Front axle**

2 Measure distance "V1" from check bore "K" to outside bore in lower control arm using beam compass or using telescoping measuring bar (06) and measuring bolt with point (024b), length 117 mm.

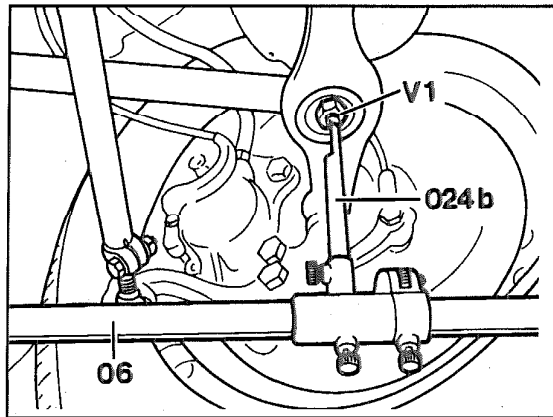

P40-2322-13

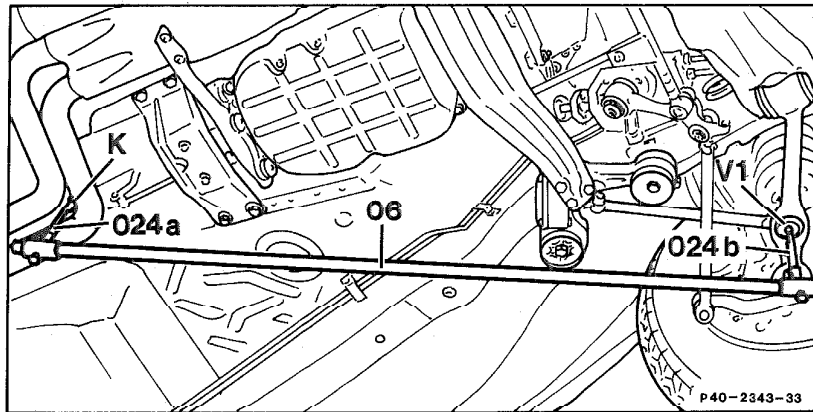

P40-2343-33

P40-2343-33

3 Measure distance "V2" from check bore "K" to hex. nut of front bearing in frame side member left and right using beam compass or using telescoping measuring bar (06) and measuring bolt with point, length 212 mm (024c).

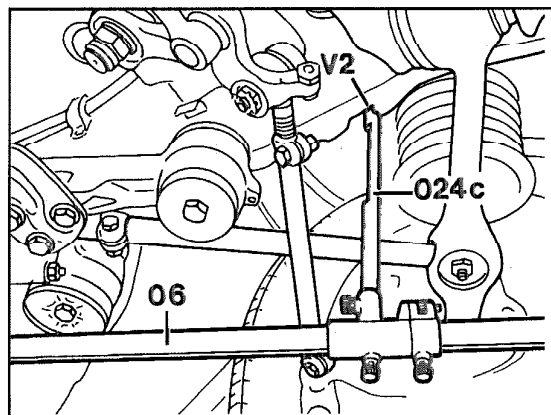

P40-2325-13

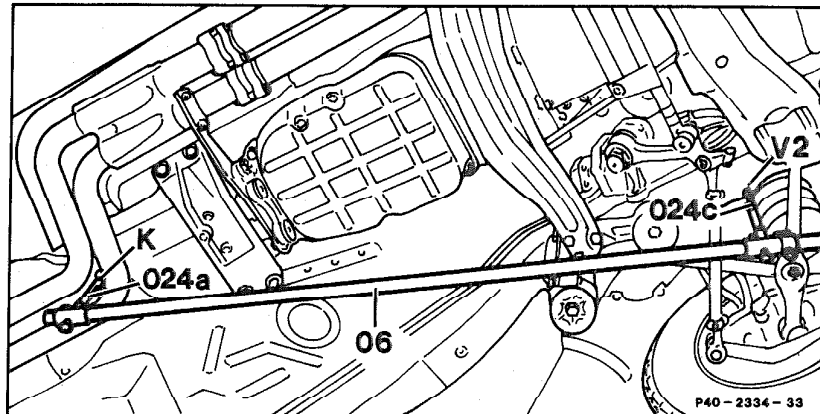

P40-2334-33

4 Measure distance "V3" from check bore "K" to left and right pivot bracket of braking support arm and cross member using beam compass, measuring length 1500 mm or using telescoping measuring bar (06) and measuring bolt with point, length 117 mm (024b). Measuring points are each time the two hex. bolts for fastening bearing carrier to frame floor.

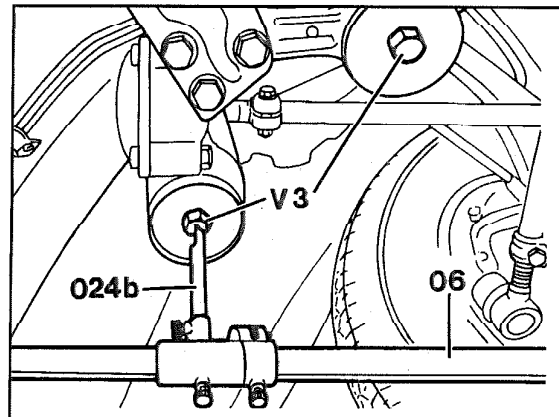

P40-2323-13

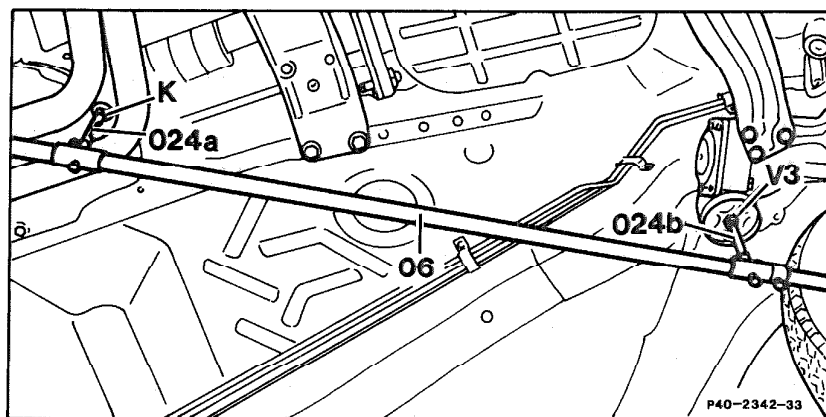

P40-2342-33

5 Measure distance "V4" from check bore "K" to locating bore "FV" in frame cross member using beam compass, measuring length 1500 mm or using telescoping measuring bar (06) and measuring bolt with point, length 45 mm (024d).

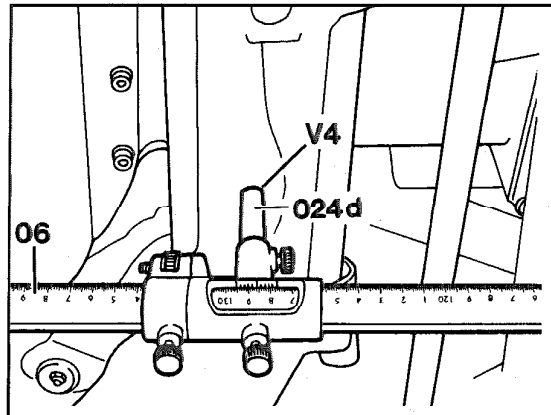

P40-2326-13

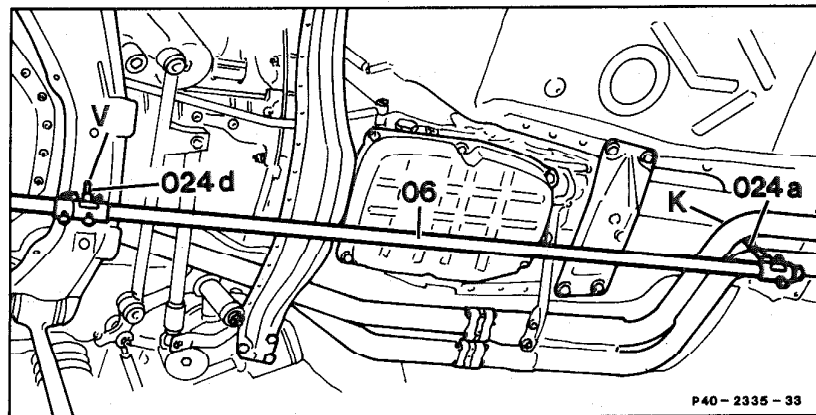

P40-2335-33

P40-2335-33

6 Measure distance "V5" of hex. screws for bearing of upper control arms on front end from left to right using beam compass, measuring length 1500 mm or using telescoping measuring bar (06) and measuring bolt with point, length 237 mm (024e), remove air cleaner for this pupose.

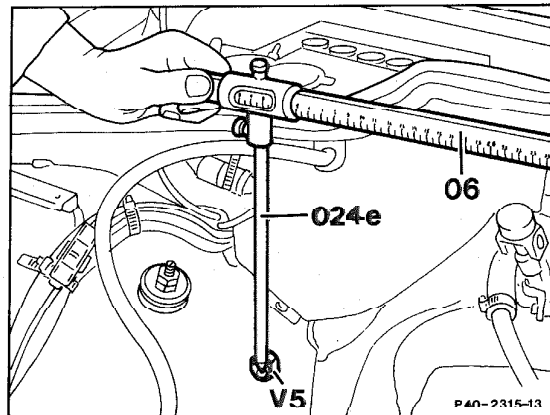

P40-2315-13

P40-2315-13

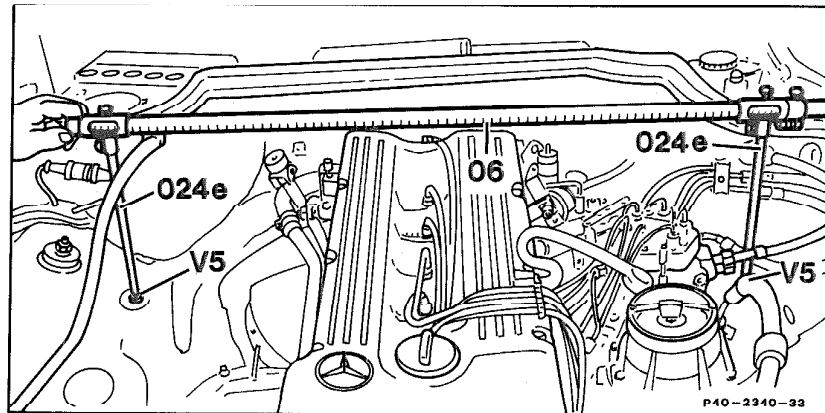

P40-2340-33

7 For measuring "V6" on frame cross member, determine center of eccentric disk (refer to arrow) and mark.

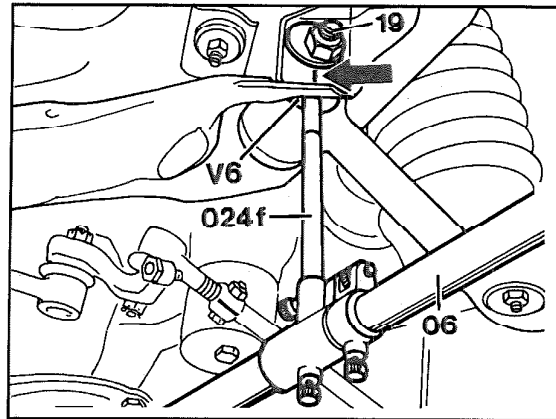

P40-2318-13

8 Measure distance "V6" from check bore "K" to bearing of lower control arm on frame cross member left and right using beam compass, measuring length 1500 mm or using telescoping measuring bar (06) and measuring bolt with point, length 152 mm (024f).

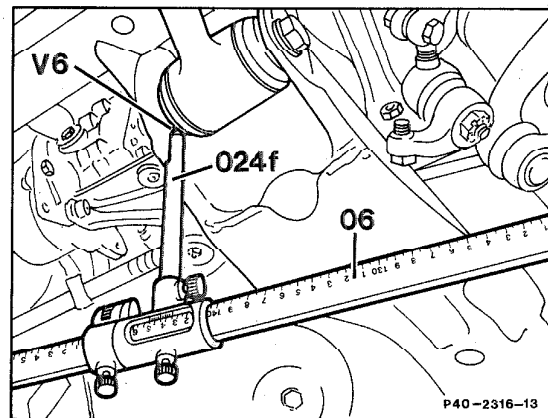

P40-2316-13

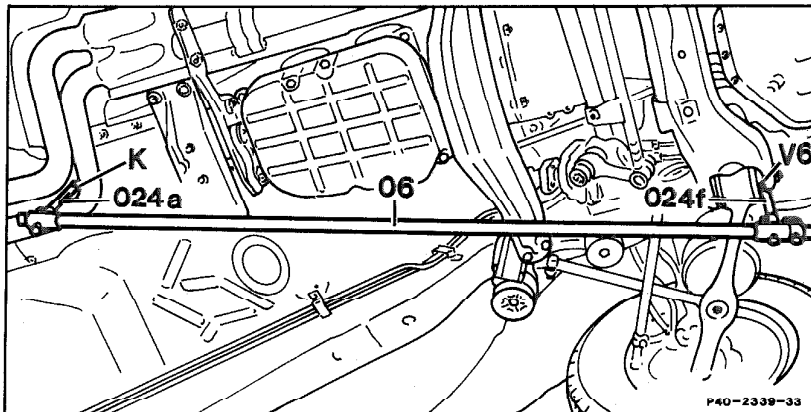

P40-2339-33

9 Measure distance "V7" of bearing carriers for supporting joints of brake support and cross member left and right using beam compass, measuring length 1500 mm or with measuring bar, measuring length 1000 mm (06) and normal measuring points (06c).

**Note**

Distance "V7" on front bearing can be measured by means of beam compass with wheels removed only for reasons of space. Measuring is required only if deviations are found at rear bearing, as well as when measuring "V8".

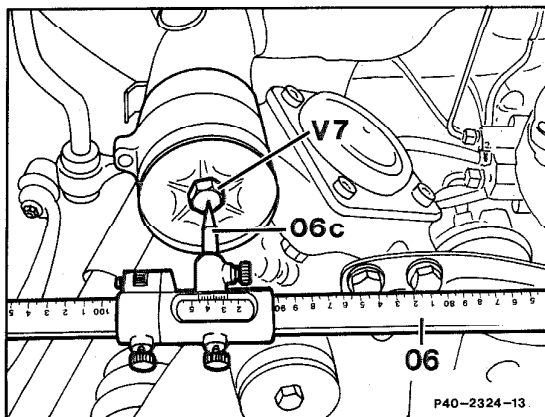

P40-2324-13  
P40-2324-13

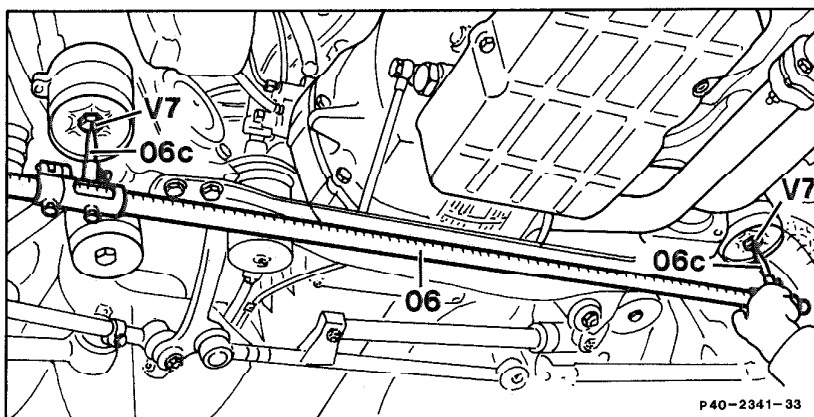

P40-2341-33  
P40-2341-33

## 40-400 Checking collision-damaged vehicles

10 Measure distance "V8" between front and rear bearing of bearing carrier for supporting joint of brake support and cross member left and right using beam compass, measuring length 1500 mm or with measuring bar, measuring length 1000 mm (06) and normal measuring points.

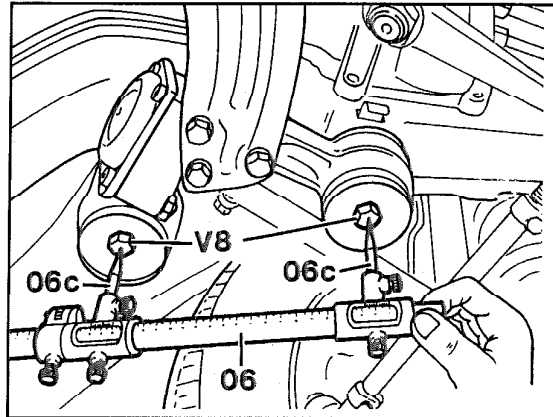

P40-2321-13

### Rear axle

11 Measure distance "H1" from check bore "K" to outer hex. screw of lower shock absorber suspension on semi-trailing arm left and right using beam compass or using telescoping measuring bar (06) and measuring point, length 100 mm (024d).

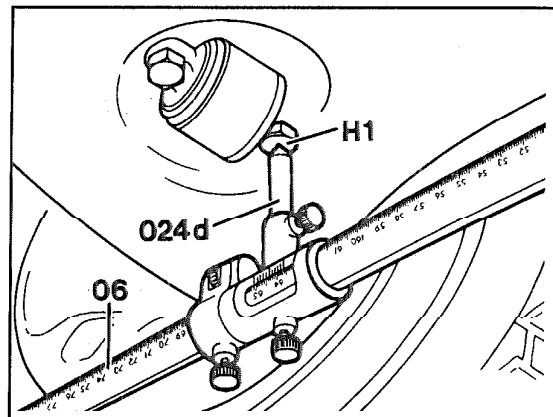

P40-2320-13

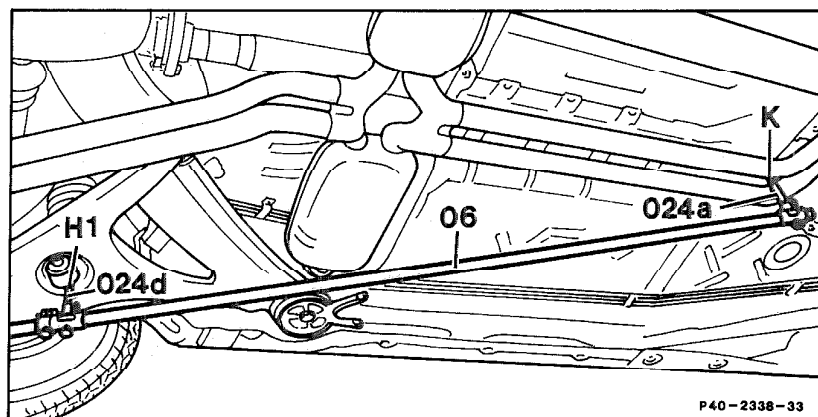

P40-2338-33

P40-2338-33

12 Measure distance "H2" from check bore "K" to hex. screw of front bearing on frame floor left and right using beam compass or using telescoping measuring bar (06) and measuring bolt with disk, length 67 mm (024g).

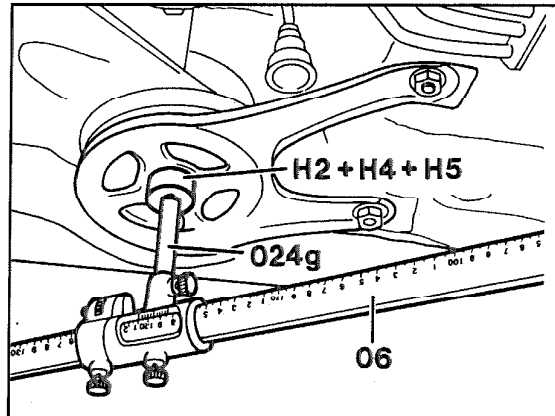

P40-2319-13

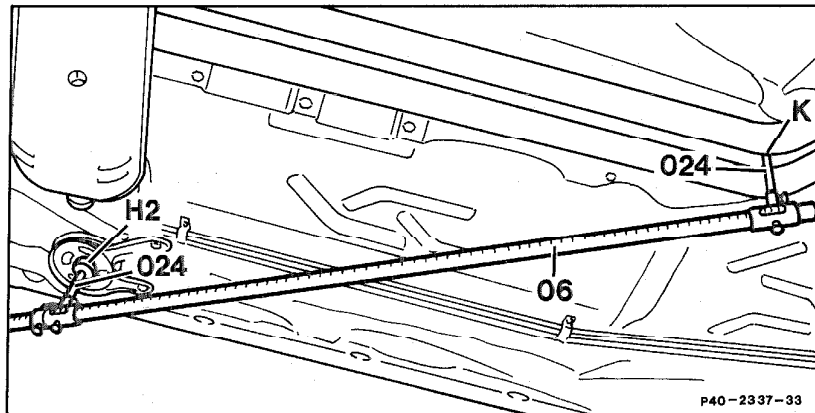

P40-2337-33

P40-2337-33

13 Measure distance "H3" from check bore "K" to locating bore "FH" in rubber mount of rear bearing using beam compass or using telescoping measuring bar (06) and measuring bolt with point (024h) of 123 589 06 63 00, length 123 mm.

**Note**

Starting 08/85 the rubber mount with locating bore "FH" has been moved 124 mm to the left.

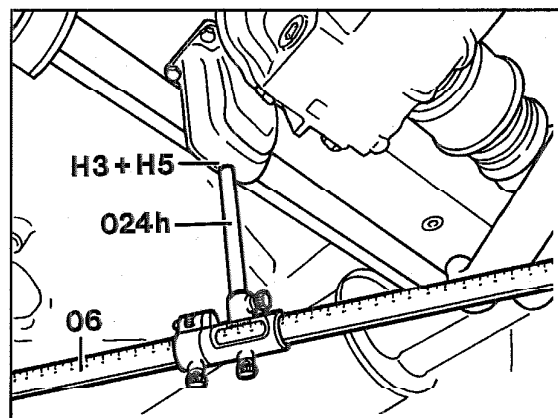

P40-2317-13

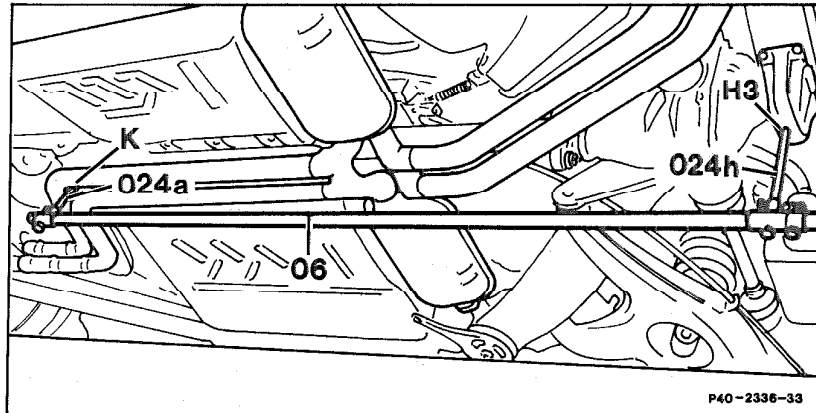

P40-2336-33

14 Measure distance "H4" of hex. screws for front bearing on frame floor left and right using beam compass or using telescoping measuring bar (06) and measuring bolt with point, length 67 mm (024g).

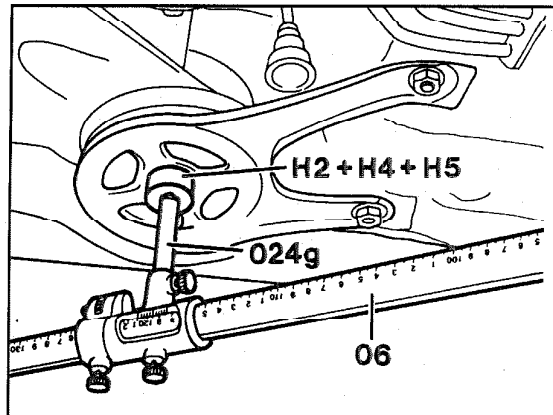

P40-2319-13

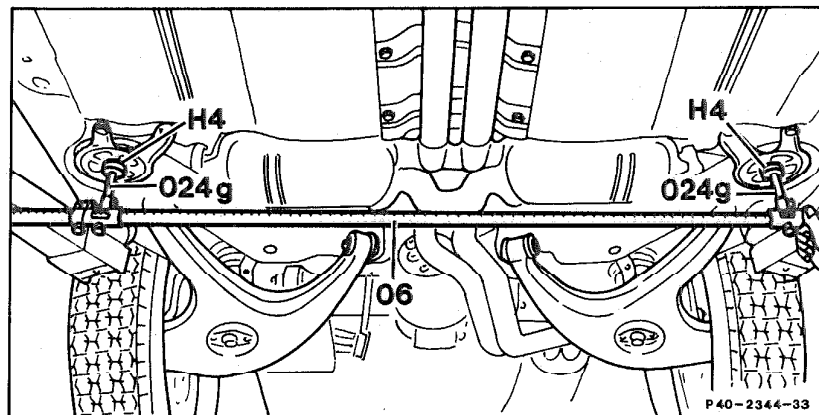

P40-2344-33

15 Measure distance "H5" from locating bore "FH" to hex. screw of front bearing on frame floor left and right using beam compass, measuring length 1500 mm or using telescoping measuring bar (06) and measuring bolt with disk, length 67 mm (024g), as well as measuring bolt with point, length 123 mm (024h).

**Note**

Starting 08/85 the rubber mount with locating bore "FH" has been moved 124 mm to the left.

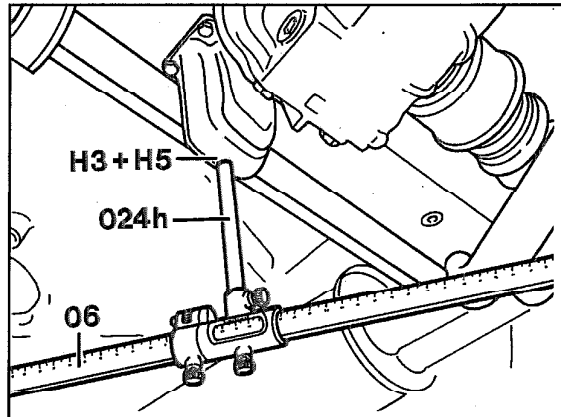

P40-2317-13

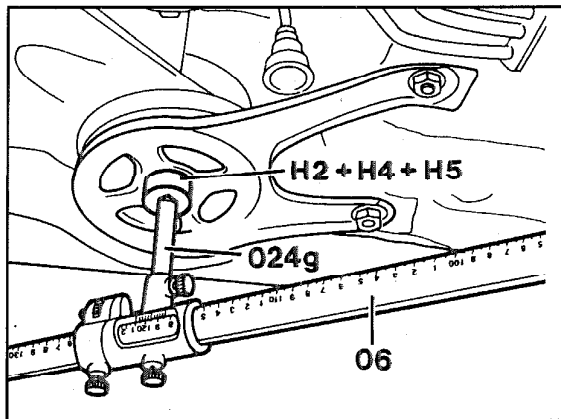

P40-2319-13

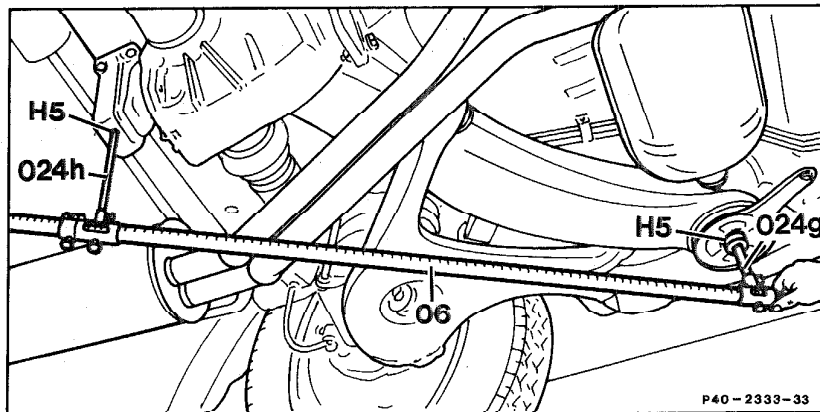

P40-2333-33

P40-2333-33