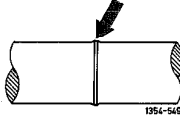
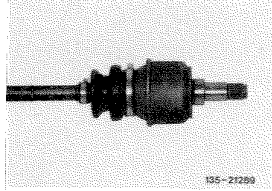
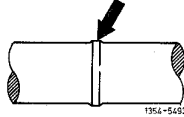
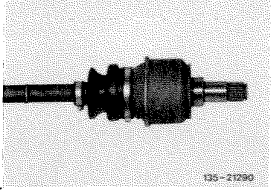
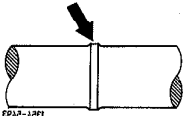
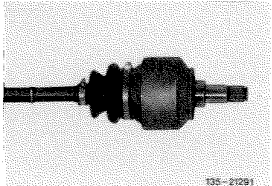

35-620 R and R rear axle shaft

A. Model 107, 114, 115, 116, 123, 126.02/03

Installation survey

| Model | Diameter of protective sleeve | | Part number | Version | Identification and differentiating characteristics of rear axle shafts |
|--|-------------------------------|------------|---|---------|--|
| | inside mm | outside mm | | | |
| 107.023 107.043 107.024 (USA) 107.044 (USA) 114.05/07 | 100 | 100 | 107 350 07 10 left ¹⁾⁵⁾ 107 350 08 10 right ¹⁾⁵⁾ | A |   |
| 114.01 114.02 115 123.02/04 123.1 | | | 115 350 42 10 left ¹⁾³⁾ 115 350 43 10 right ¹⁾³⁾ 115 350 45 10 left ²⁾³⁾⁹⁾ 115 350 46 10 right ²⁾³⁾⁹⁾ | | |
| 116.114 | | | 115 350 49 10 left ²⁾⁴⁾ 115 350 50 10 right ²⁾⁴⁾ | | |
| 123.000 123.026/028 123.04/08 123.1/2 ¹⁾¹⁾ | | | 123 350 02 10 ³⁾⁹⁾ left and right without oil return feed thread | | |
| 107.022/023 107.042/043 107.024 (USA) 107.044 ⁷⁾¹⁰⁾ (USA) 114.06/07 123.03 | 100 | 100 | 107 350 10 10 left ¹⁾⁶⁾ 107 350 11 10 right ¹⁾⁶⁾ 107 350 27 10 left ²⁾⁶⁾ 107 350 28 10 right ²⁾⁶⁾ | B |   |
| 107.022/042 107.025/045 123.03/05 123.093 123.125/193 | | | 107 350 33 10 ¹⁾¹⁾ left and right without oil return feed thread | | |
| 107.024 107.044 ⁸⁾ (except (USA)) 107.026 107.046 | 115 | 100 | 107 350 13 10 left ¹⁾ 107 350 14 10 right ¹⁾ 107 350 23 10 left ²⁾ 107 350 24 10 right ²⁾ 107.350 34 10 ¹⁾¹⁾ left and right without oil return feed thread | C |   |
| | | | | | |

35-620 R and R rear axle shaft

- 1) Rear axle shaft with M 12-threads on outer joint (1st version up to December 1973).
- 2) Rear axle shaft with M 8-threads on outer joint (2nd version starting January 1974).
- 3) These rear axle shafts are installed during production only. In the event of repairs, install version "B".
- 4) Up to chassis end no. 027 059 and starting chassis end no. 040 339 install only rear axle shafts with 32 mm dia. Starting chassis end no. 027 060 up to chassis end no. 040 338 install version "B" in the event of repairs (chassis with vibration eliminator).
- 5) 1st version up to September 1972 (with yellow color code on protective sleeve).
In the event of repairs, install version "B".
- 6) 2nd version on models 107.023/024/043/044, 114.06/07 starting October 1972. In the event of repairs of series 114.01, 114.02, 115, 123.02/04/08/1 replacement for version "A"
- 7) Installed up to chassis end no. 029 598.
- 8) Starting chassis end no. 029 599 also installed on USA vehicles.
- 9) Except model 123.125.
- 10) Installed starting chassis end no. 053 399. In combination with ring-shaped weight on inner joints of rear axle shafts.
- 11) Replaces former rear axle shaft in combination with a radial sealing ring with oil return feed thread.

35-620 R and R rear axle shaft

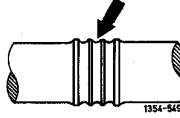
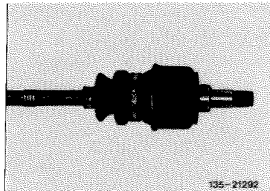
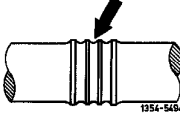
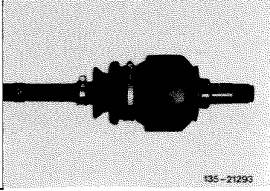
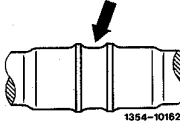
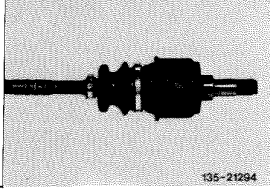
| Model | Diameter protective sleeve | | Part number | Version | Identification and differentiating characteristics of rear axle shafts |
|--|----------------------------|------------|---|---------|--|
| | inside mm | outside mm | | | |
| 116.02 116.032 (USA) 116.033 (USA) | 100 | 100 | 116 350 09 10 left ¹⁾ 116 350 10 10 right ¹⁾ | D |   |
| 126.02 | | | 116 350 29 10 left ²⁾ 116 350 30 10 right ²⁾ | | |
| 116.032 116.033 116.036 | 115 | 100 | 116 350 11 10 left ¹⁾ 11 350 12 right ¹⁾ | E |   |
| 126.120 | | | 116 350 25 10 left ²⁾ 116 350 26 10 right ²⁾ | | |
| 126.032 125.033 | 100 | 100 | 126 350 02 10 | F |   |
| 126.036 126.037 | | | 115 | | |

¹⁾ Rear axle shaft with M 12 threads on outer joint (1st version up to December 1973).
²⁾ Rear axle shaft with M 8 thread on outer joint (2nd version starting January 1974).
¹⁾ Replaces former rear axle shaft in combination with a radial sealing ring with oil return feed thread.

35-620 R and R rear axle shaft

Oil types and capacities

| | | | |
|---|---|---|-------------|
| Standard differential | Hypoid gear oil SAE 90 refer to specifications for service products page 235 | | |
| Differential with restricted slip (positive traction) (name plate on rear axle housing) | Special Hypoid gear oil refer to specifications for service products page 235.3 | | |
| Capacity | large center piece ¹⁾ | 1.3 litres | |
| | small center piece ¹⁾ | 1st version with cast iron rear axle end cover | 1.15 litres |
| | | 2nd version with aluminium rear axle end cover | 1.0 litre |

¹⁾ Refer to installation survey rear axle center piece 35-500

Spacing ring between inner synchromesh joint and differential housing

| | |
|---|---|
| Assembly instructions for correct selection of spacing ring | There should be no noticeable end play between inner synchromesh joint and differential housing. However, the locking ring should still permit turning in groove. |
|---|---|

| | | |
|--------------|-----------|--------------------------------|
| Spacing ring | thickness | from 0.7 to 1.50 ²⁾ |
| | | from 2.60 to 3.40 |
| | depth | from 0.1 to 0.1 |

²⁾ With rear axle center piece without lateral bearing caps

| Tightening torques | | Nm |
|--|------------------|----|
| Hex bolt for attaching rear axle shaft to rear axle shaft flange | 1st version M 12 | 95 |
| | 2nd version M 8 | 30 |
| Hex bolts for attaching rear axle end cover to rear axle housing | | 45 |
| Hex bolts for attaching rear rubber bearing to frame floor | | 25 |
| Hex bolts, self-locking, for attaching rear rubber bearing to frame floor | | 30 |
| Threaded bushing in rear axle shaft for reduction of M 12 to M 8 (repair version) | | 30 |

35-620 R and R rear axle shaft

Special tools

Assembly tool
for rear axle shaft

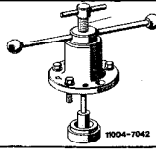

116 589 24 61 00

Vehicle jack top

large center piece

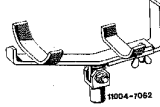

116 589 02 63 00

Vehicle jack top

small center piece

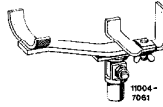

115 589 35 63 00

Self-made tool

Tool for
screwing-in
threaded bushing

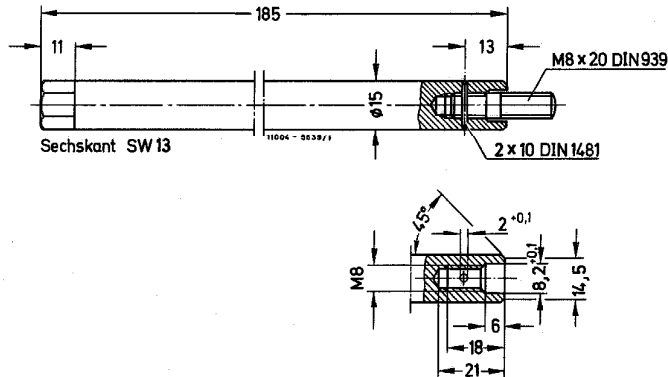

Note

These instructions cover the removal and installation of rear axle shafts for all models. On vehicles with starting torque compensation there are small deviations which are described.

If both rear axle shafts are to be exchanged, it will be of advantage to remove the complete rear axle center piece.

Rear axle center piece with lateral bearing caps

- | | |
|---------------------------|-----------------------|
| 3 Rear axle housing | 26 Locking ring |
| 16 Side gear | 27 Spacing ring |
| 17 Thrust washer | 28a Rear axle shaft |
| 18 Differential pinion | 28c Inner spider |
| 19 Ball washer | 28d Spider joint hub |
| 20 Differential bolt | 28e Ball |
| 20a Clamping sleeve | 28f Stop buffer |
| 21 Tapered roller bearing | 28g Protective sleeve |
| 22 Sealing ring | 28h Sealing ring |
| 23 Compensating washer | 28i Stop sleeve |
| 24 Bearing cap | 28k Sealing ring |
| 25 Radial sealing ring | |

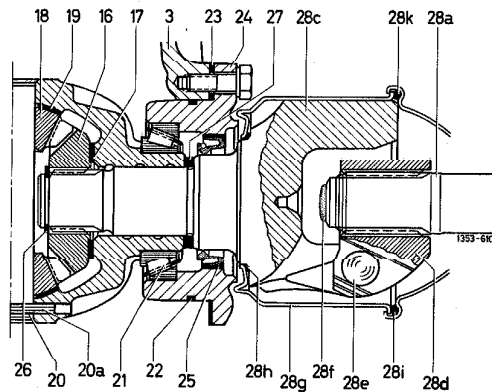

Rear axle center piece without lateral bearing caps

- 12 Differential housing
- 35 Locking ring
- 36 Spacing ring
- 37 Rear axle shaft

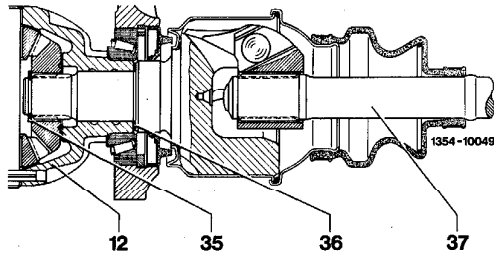

Removal

- 1 Drain oil from rear axle.
- 2 Unscrew caliper at respective end and hang up with a hook. Not required for rear axles with starting torque compensation.

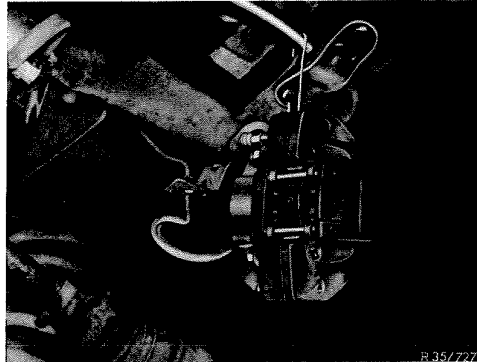

On rear axle with starting torque compensation, if required, unscrew brake hose on holder and close brake line as well as brake hose against penetration of dirt.

- 3 Loosen hex bolt M 12 of 1st version or hex bolt M 8 of 2nd version with spacing sleeve and clamping disc for attaching rear axle shaft to rear axle shaft flange and remove.

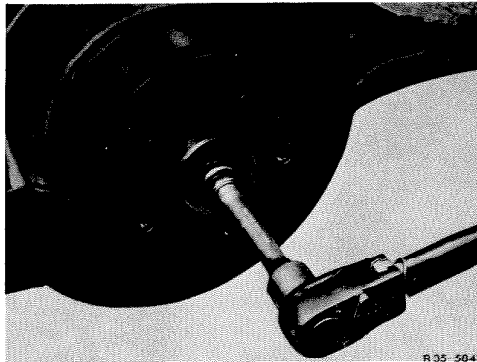

- 4 Force rear axle shaft out of rear axle shaft flange by means of assembly tool.

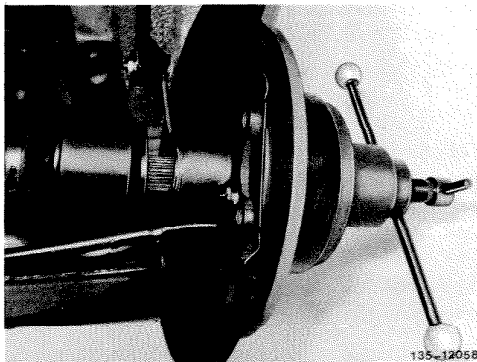

35-620 R and R rear axle shaft

Attention!

When removing assembly tool, be sure to hold rear axle shaft in place. Do not permit rear axle shaft to drop, since this will damage the synchromesh joint and result in leaks. If on models 114 and 115 the rear axle shaft cannot be removed in spite of being completely telescoped, loosen upper shock absorber suspension and lower semitrailing arm against deflection stop.

On models 107, 116, 123 and 126 loosen rear axle center piece from rear axle carrier and lower until studs are out of rear axle carrier (concerns mainly vehicles with starting torque compensation). Swivel rear axle center piece to pertinent side until rear axle shaft can be removed.

5 Support rear axle housing with pitlift or vehicle jack and respective top.

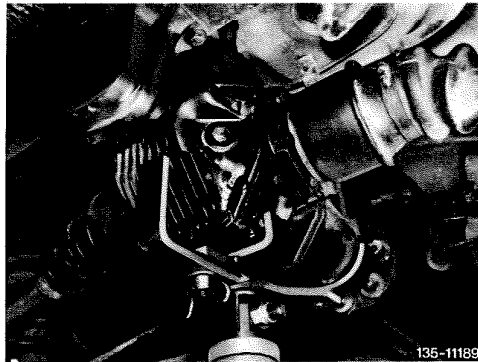

6 On 1st version of rubber bearing, unscrew hex. socket necked-down bolt for rubber bearing on rear axle end cover. (Model 114 and 115) On 2nd version, unscrew hex. bolts from rubber bearing.

7 Clean rear axle housing. Unscrew hex. bolts for attaching cover to rear axle housing and remove cover.

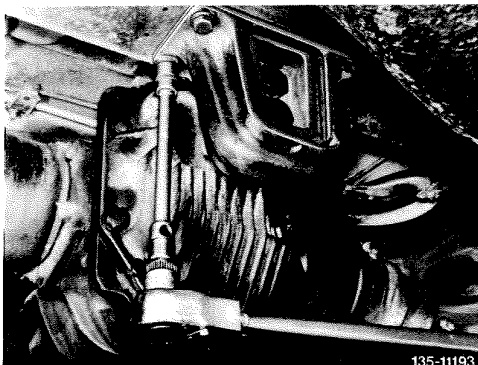

Rear rubber bearing of 2nd version

8 Pull off locking ring (26) between inner synchronesh joint and side gear by means of pliers (1) or a hook and remove from housing.

9 Pull rear axle shaft out of side gear and remove together with spacing ring.

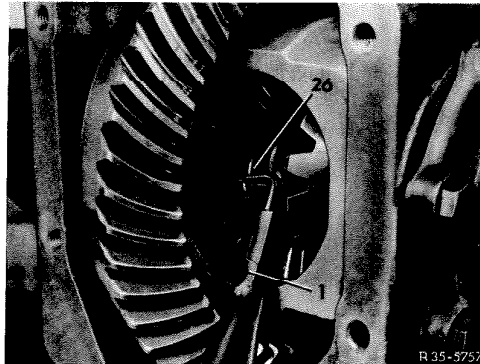

Installation

Attention!

Rear axle shafts are provided with oil return threads (twist) on running surface of radial sealing ring, which are different for left and right. For identification, the face of the inside joint is provided with an electrically written "R" for the righthand side and an "L" for the lefthand side. The oil return feed thread or the identification is in place up to September 1979 on models 107.023/024/043/044, 116.028/029/03 and up to February 1981 on models 107.022/042 and 123.

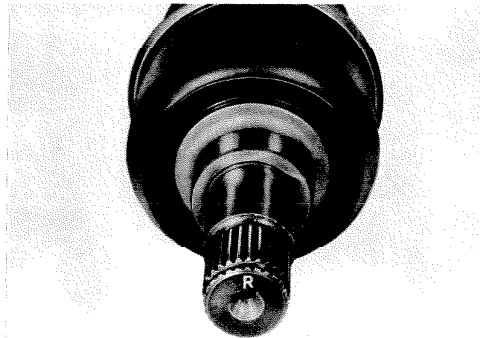

10 Refinish oil return feed thread, if required, with emery cloth (grit 180) at an angle of approx. 20° and for a length of 20-30 mm.

Note: When installing a radial sealing ring with alternating feed thread, refinishing of oil return feed thread is not necessary. If a rear axle shaft is installed without oil return feed thread, make sure that a radial sealing ring with alternate feed thread is installed.

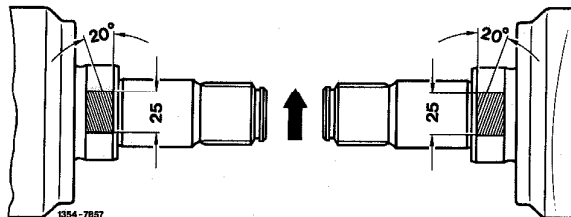

11 If a new rear axle shaft is installed, place the previously removed spacing ring (11) on inner synchronesh joint.

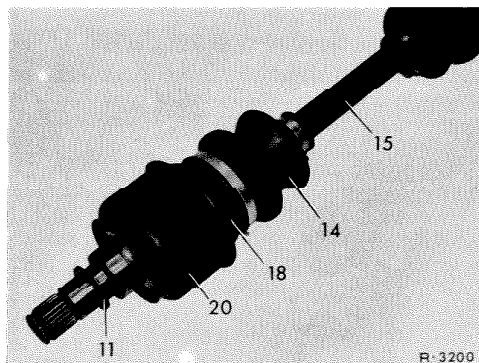

35-620 R and R rear axle shaft

12 Introduce complete rear axle shaft into side gear and insert new locking ring into groove of inner synchromesh joint.

Attention!

If the rear axle shaft cannot be introduced into differential housing up to contact surface, contract both joints first. Then apply light blows with a plastic hammer against outer spider to knock rear axle shaft against contact surface of differential housing. Do not apply hammer blows against stop sleeve.

Do not permit rear axle shaft to drop or to bend sharply, since this will damage housing for synchromesh joint and result in leaks.

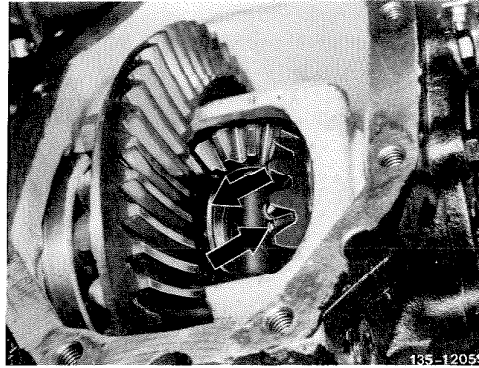

13 Check end play between inner spider and differential housing. There should be no noticeable end play; the locking ring (26) should just barely turn in groove. If required, use thicker or thinner spacing ring (27).

Attention!

Renew locking ring after one-time use.

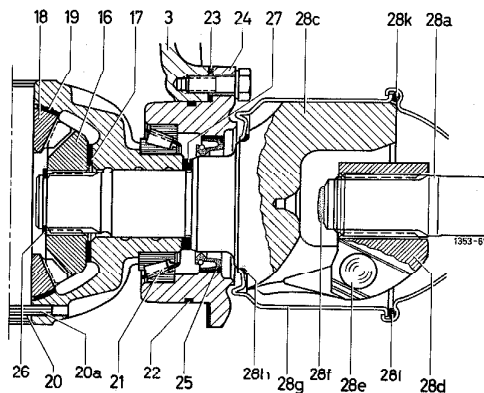

14 Telescope rear axle shaft completely and insert into rear axle shaft flange (78) by means of assembly tool (05a-05c).

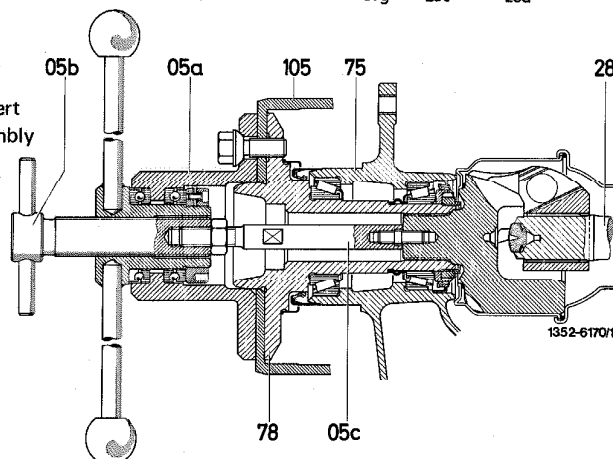

15 On version 1, tighten hex. screw M 12 to 95 Nm.
On version 2, mount hex. screw M 8 with clamping disc and spacing sleeve and tighten to 30 Nm.

Attention!

Renew clamping disc after one-time use. Provide clamping disc with oil in range of screw head. Pay attention to correct length of spacing sleeve and hex. screw (refer to 35-110).

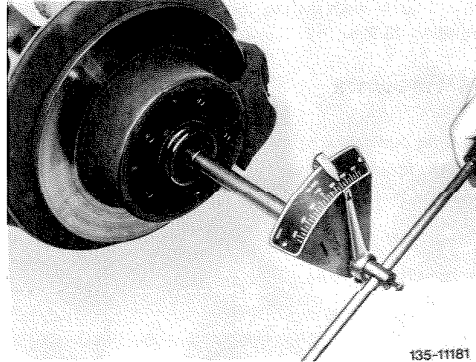

135-11181

Note: In the event of complaints about clicking noises, exchange hex. screw M 12 with a thick washer for a hex. screw M 8 with pertinent spacing sleeve and clamping disc. To reduce threads, screw a threaded bushing (79c) into rear axle shaft by means of self-made tool (details at the left). Tightening torque of threaded bushing 30 Nm.

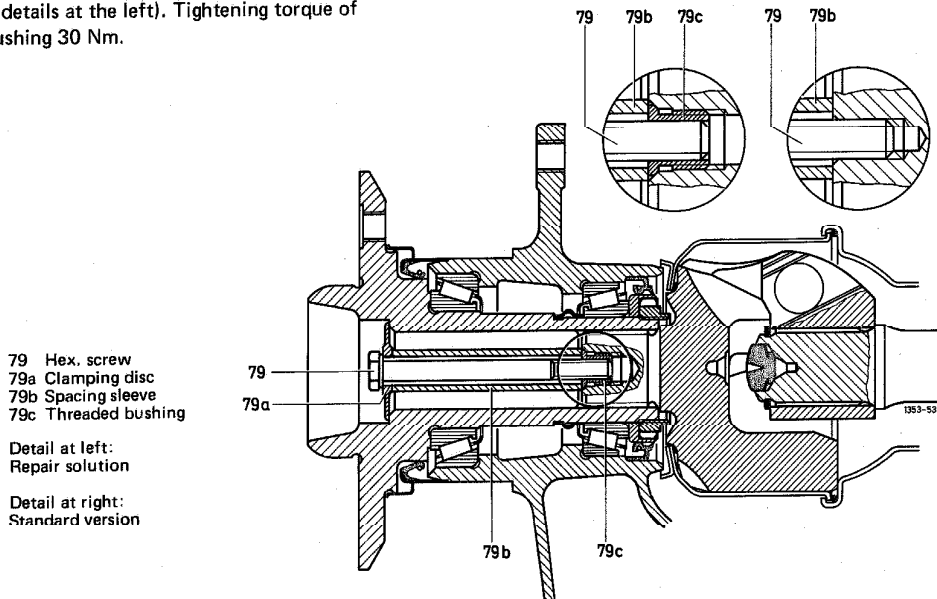

79 Hex. screw
79a Clamping disc
79b Spacing sleeve
79c Threaded bushing

Detail at left:
Repair solution

Detail at right:
Standard version

Attention!

When installing a new or a reconditioned rear axle shaft with one-piece protective sleeve on outer joint, check semi-trailing arm in operating range of protective sleeve for weld residue. Remove weld beads, since otherwise the protective sleeve may be chafed through. Also check installed rear axle shaft for wiping noises. If wiping noises are heard when rotating rear axle shaft, refinish wheel carrier in operating range of protective sleeve (arrows).

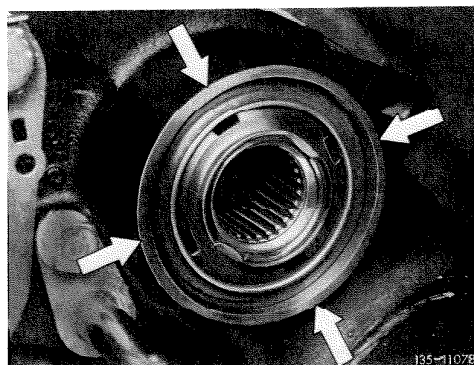

135-11078

35-620 R and R rear axle shaft

16 Mount rear axle end cover with sealing compound and tighten hex. screws to 45 Nm.

Model 107, 114, 115, 116 and 123

17 Lift rear axle housing and screw rubber bearing to frame floor. Tighten hex. screws (version 1) to 25 Nm or self-locking hex. screws (version 2) to 30 Nm.

Attention!

Use self-locking hex. screws only once.

Model 126

18 Lift rear axle center piece up to frame floor and attach rubber bearing to frame floor. Tightening torque of self-locking hex. screws of version 1 or hex. screws of version 2 30 Nm.

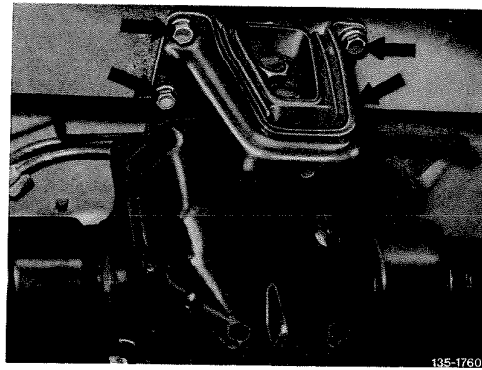
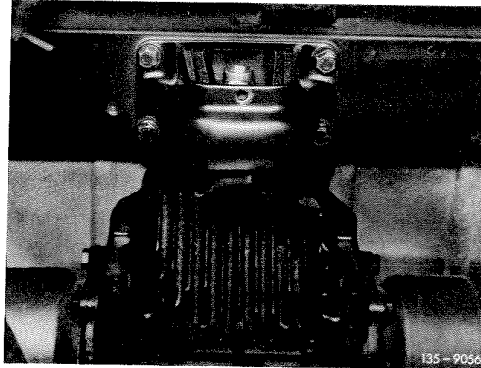

19 In the event of repairs, replace version 1 by version 2.

Version 1
Self-locking hex. screws (arrow) and holder with nut without lock.

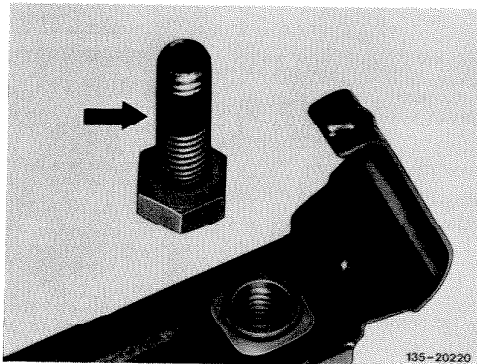

Attention!

Always renew holder of version 2 after one-time use on principle.

Version 2
Hex. screws without lock and holder with self-locking nuts (arrow).

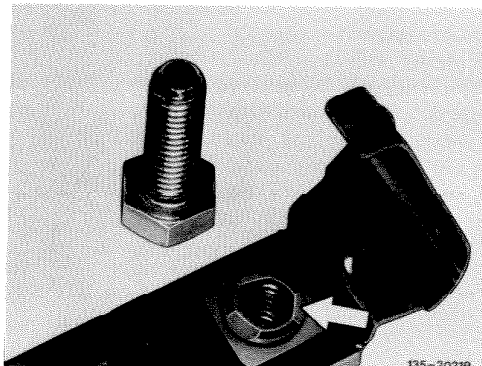

20 On rear axles with starting torque compensation, if removed:

Mount brake hose.

Bleed brake system (42-010).

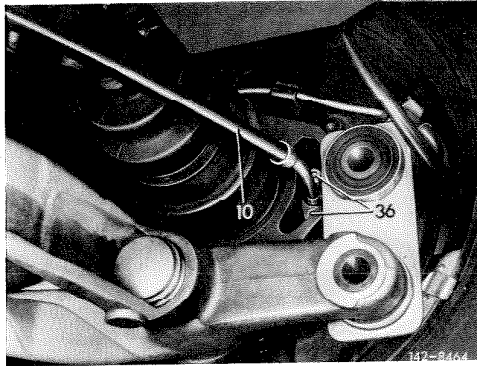

21 Remove vehicle jack or pitlift and top.

22 On rear axles without starting torque compensation mount caliper with new locking plate or self-locking hex bolts. Tightening torque of hex bolts 90 Nm.

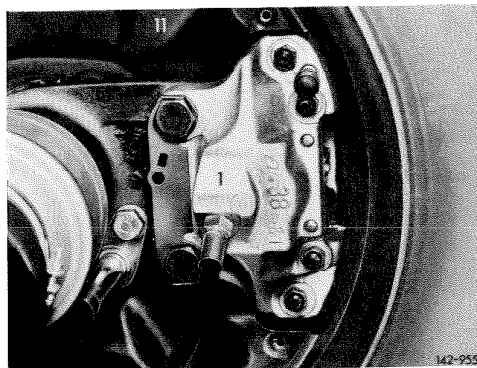

23 Fill rear axle housing with oil up to level of filler hole.

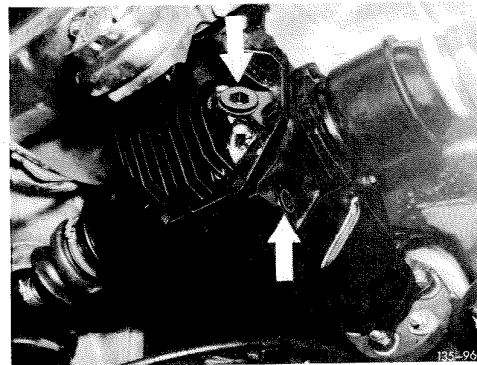

35-620 R and R rear axle shaft

B. Model 126.04

Installation survey

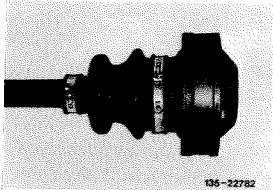
| | Diameter of joints | | Part No. | Identification and differentiating characteristics of rear axle shafts |
|--------|--------------------|------------|---------------|--|
| | inside mm | outside mm | | |
| 126.04 | 120 | 102 | 126 350 04 10 |  |

Tightening torques

| | Nm |
|--|---------|
| Hex. head screw for fastening rear axle shaft to rear axle shaft flange | 30 |
| Hex. socket screws, self-locking, for fastening rear axle shaft to connecting flange | 125-145 |

Special tools

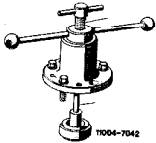
| | | |
|--------------------------------------|---|------------------|
| Assembly fixture for rear axle shaft |  | 116 589 24 61 00 |
|--------------------------------------|---|------------------|

Note

During removal and installation of rear axle shaft, the rear end cover need not be removed. Separation is made between joint and connecting flange.

Layout rear axle center piece -- rear axle shaft

| | | | |
|-----|---------------------------|-----|------------------|
| 3 | Rear axle housing | 26 | Locking ring |
| 16 | Differential side gear | 27 | Spacing ring |
| 17 | Thrust washer | 28a | Rear axle shaft |
| 18 | Differential pinion | 28c | Inner joint ring |
| 19 | Spherical washer | 28d | Joint hub |
| 20 | Differential pinion shaft | 28e | Ball |
| 20a | Tensioning sleeve | 28f | Ball cage |
| 21 | Tapered roller bearing | 28g | Locking ring |
| 22 | Sealing ring | 28h | End cover |
| 23 | Compensating washer | 28i | Sleeve cap |
| 24 | Bearing cap | 28k | Hose clamp |
| 25 | Radial sealing ring | 28l | Rubber sleeve |

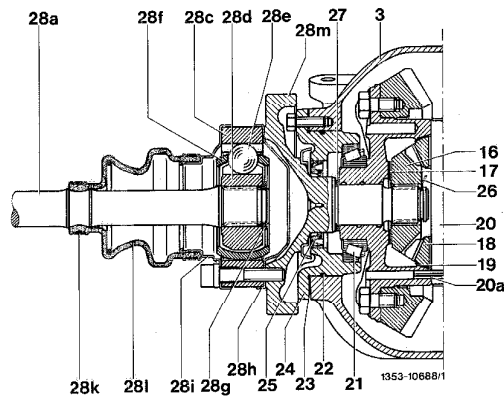

Removal

1 Loosen and remove hex. head screw with spacing sleeve and washer for fastening rear axle shaft to rear axle shaft flange.

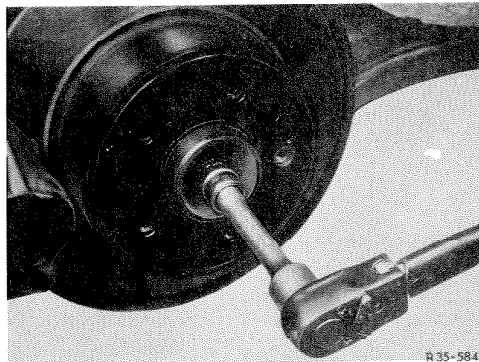

2 Loosen and remove hex. socket screws from rear axle shaft to connecting flange.

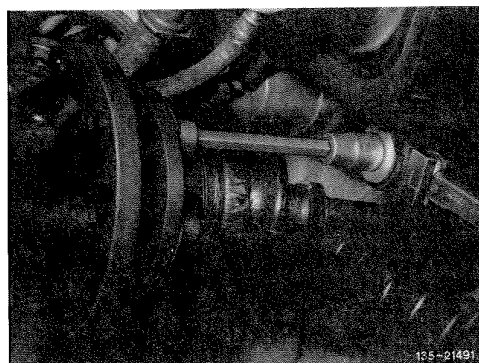

35-620 R and R rear axle shaft

3 Loosen inner joint of rear axle shaft from connecting flange and compress. Make sure that the end cover is not damaged while loosening joint (arrow).

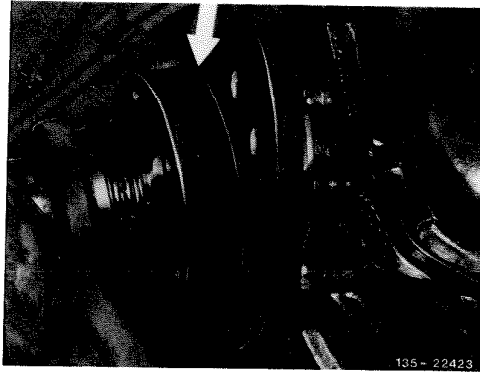

4 If required, force rear axle shaft out of rear axle shaft flange by means of assembly fixture.

Attention!

When removing assembly fixture, be sure to hold rear axle shaft in place. Do not drop rear axle shaft, since this might damage housing for synchronized joint.

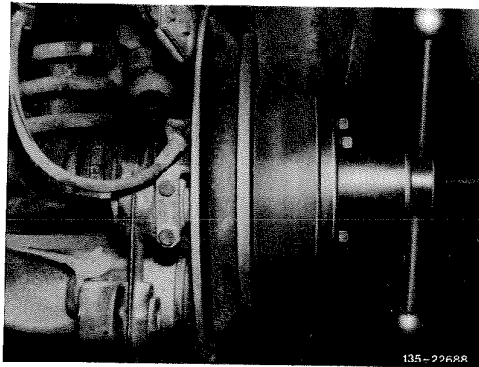

5 Remove rear axle shaft.

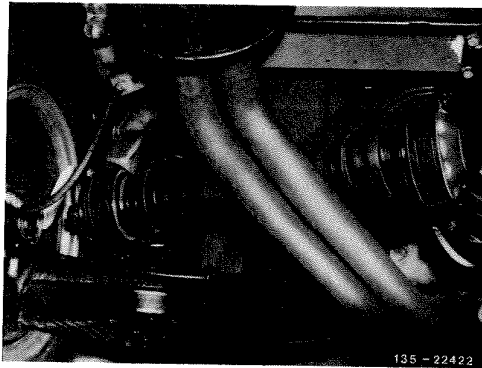

Installation

6 For installation proceed vice versa, paying attention to the following items:

- a Renew hex. socket screws, self-locking, on principle. Tightening torque 125-145 Nm.
- b Clean contact surface between end cover of rear axle shaft and connecting flange, if contaminated.

c Renew clamping plate for fastening rear axle shaft to rear axle shaft flange after one-time use. Provide clamping plate with oil in range of screw head.

d Tightening torque of hex. head screw for fastening rear axle shaft to rear axle shaft flange 30 Nm.

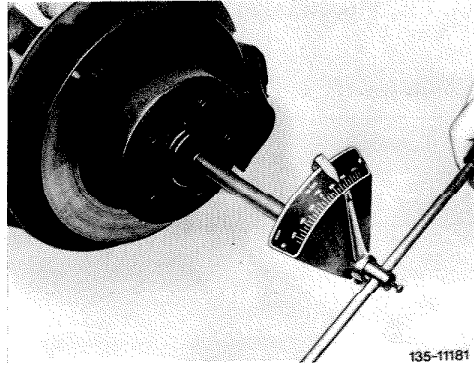

35-620 R and R rear axle shaft

Preliminary work:
R and R wheels for light alloy rim (40-110).

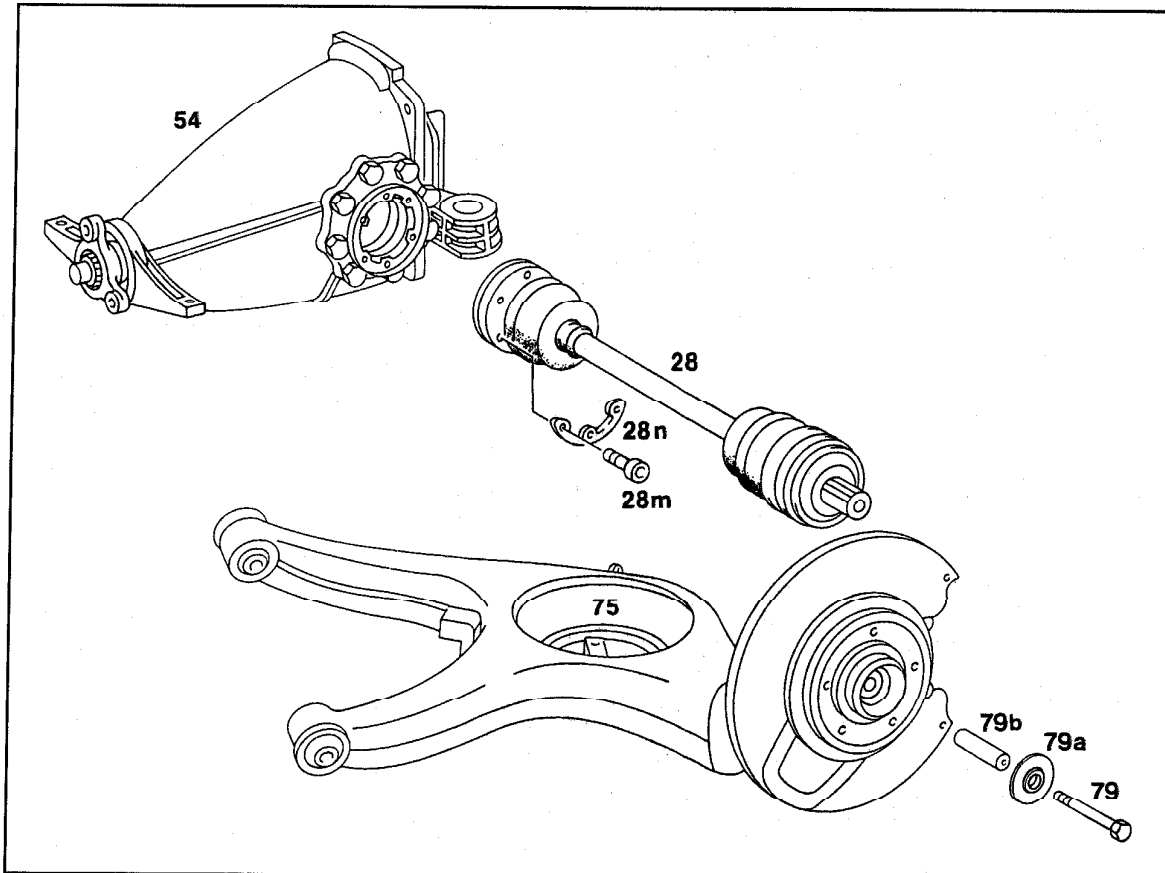

P35-0100-57

- | | |
|----------------------------|--|
| Rear axle shaft (28) | remove at connection flange, install. Replace retaining bolts (28m) and washers (28n). M10 = 70 Nm with threads and bolt head contact surface oiled, M12 = 125-145 Nm. Torque wrench 001 589 67 21 00 (step 1). |
| Rear axle shaft | remove at rear axle shaft flange, install. Replace tensioning washer (79a) and coat with oil in area of bolt head contact surface, 30 Nm, torque wrench 001 589 66 21 00. Press off axle shaft with installation tool 201 589 00 61 00 if tight (steps 2, 3). Observe installation survey. |

35-620 R and R rear axle shaft

Installation survey

| Model | Rear axle shafts with ring joint, part no. ³⁾ | Connecting flange without ring-shaped weight, part no. ³⁾ | Identification of rear axle shafts and connecting flanges |
|-----------|--|--|---|
| 126.02 | 126 350 29 10 | | |
| | 126 350 39 10 with ASD ¹⁾ | | P35-0088-81 |
| | 126 350 70 10 with ASR ¹⁾ | 124 350 26 45 | |
| | | 124 350 37 45 with ASD | P35-0090-81 |
| | | 124 350 49 45 with ASR | P35-0092-81 |
| | | | P35-0089-81 |
| 126.03/04 | 126 350 64 10 ²⁾ | | |
| | 126 350 65 10 with ASR ¹⁾ | | 1354-5493 |
| | | 126 350 04 45 without cap centering up to approx. 01/89 | |
| | | 126 350 18 45 with cap centering starting approx. 02/89 | 1354-16085 |
| | 126 350 12 45 with ASR without cap centering up to approx. 01/89 | | |
| | 126 350 19 45 with cap centering starting 02/89 | | P35-0090-81 |

¹⁾ On vehicles with ASD or ASR the rear axle shaft is marked with an 8 mm wide collar (arrow).

³⁾ Status 08/90

35-620 R and R rear axle shaft

| Model | Rear axle shafts with ring joint, part no. ³⁾ | Connecting flange without ring-shaped weight, part no. ³⁾ | Identification of rear axle shafts and connecting flanges |
|---------|---|--|---|
| 126.125 | 126 350 29 10 | | P35-0088-81 |
| | | 124 350 26 45 | |
| | | | P35-0090-81 |
| 126.13 | 126 350 54 10 | | |
| | 126 350 70 10 ¹⁾ with ASD starting model year 1990 | | 1354-16073 |
| | | 129 350 04 45 or 129 350 08 45 with cap centering | 1354-16074 P35-0094-81 |

- ¹⁾ On vehicles with ASD or ASR the rear axle shaft is marked with an 8 mm wide collar (arrow).
²⁾ Rear axle shaft marked with 3 mm wide collar.
³⁾ Status 08/90

35-620 R and R rear axle shaft

| Model | Rear axle shafts with ring joint, part no. ³⁾ | Connecting flange without ring-shaped weight, part no. ³⁾ | Identification of rear axle shafts and connecting flanges |
|--------|---|---|---|
| 126.13 | 126 350 70 10 ¹⁾ with ASD starting model year 1990 | 124 350 37 45 with ASD without cap centering 124 350 58 45 with ASD with cap centering, phased in starting model year 1990 | P35-0092-81 1354-16074 |

¹⁾ On vehicles with ASD or ASR the rear axle shaft is marked with an 8 mm wide collar (arrow).

³⁾ Status 08/90

Special tools

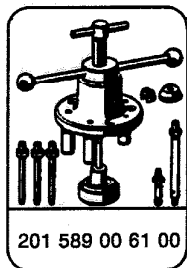
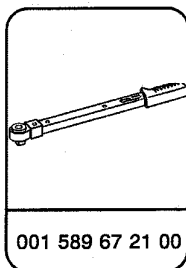
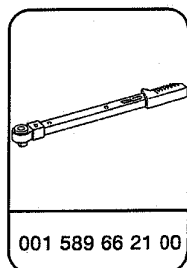

Note

It is not necessary to remove the differential housing cover for removal and installation of the rear axle shaft. Separation is accomplished between the joint and connection flange.

35-620 R and R rear axle shaft

Removal, installation

1 Remove rear axle shaft at connection flange, install.

Installation note

Replace retaining bolts (28m) and washers (28n). Retaining bolts M10 = 70 Nm with threads and bolt head contact surface oiled, M12 = 125-145 Nm.

Torque wrench 001 589 67 21 00.

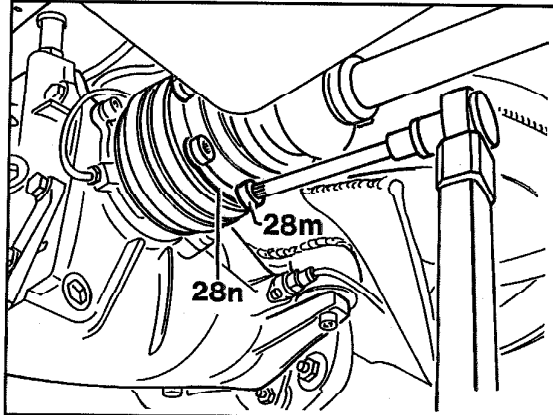

0135-36345

CAUTION!

If necessary clean dirt and wax off of pressure surface between end cover for rear axle shaft and connection flange (arrow).

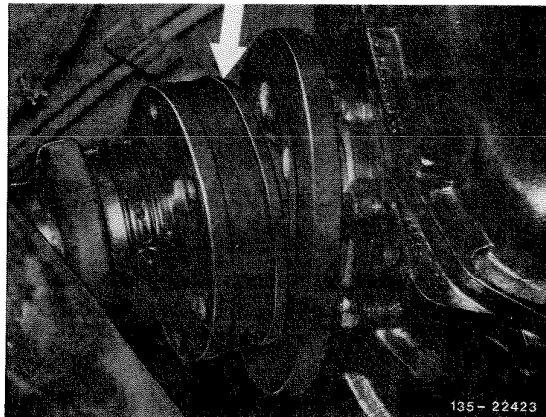

135-22423

135-22423

2 Remove hex. head bolt with spacer sleeve and tensioning washer for mounting rear axle shaft to rear axle shaft flange, install.

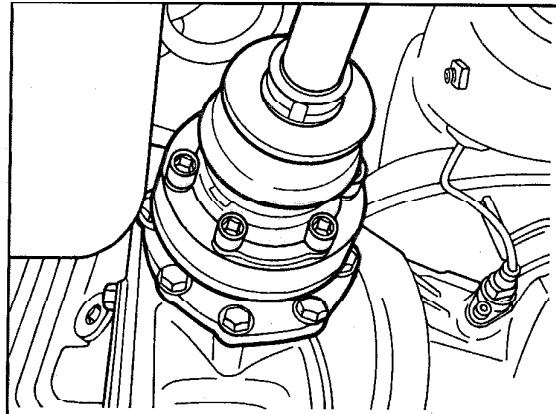

P35-2106-13

Installation note

Replace tensioning washer (79a). Coat tensioning washer with oil in area of bolt head contact. Tightening torque 30 Nm.

Torque wrench 001 589 66 21 00.

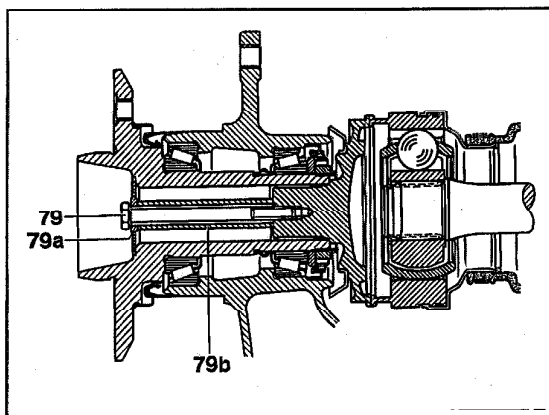

P35-0058-13

3 If necessary press rear axle shaft out of rear axle shaft flange with installation tool.

⚠ CAUTION!

When removing installation tool, hold rear axle shaft tightly under all circumstances. Do not allow rear axle shaft to fall, otherwise the housing for the constant velocity joint can be damaged.

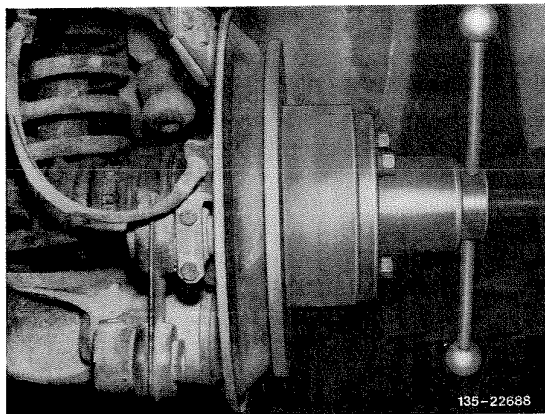

135-22688

135-22688

4 Install in opposite order.