

## 35-110 R and R semi-trailing arm

### Slide fluid for pressing-in rubber bearings

Slide fluid (Naphtolene H or slide paste Fahr)	000 989 08 60
--	---------------

### Tightening torques

Nm

Hex nut for attaching semi-trailing arm to rear axle carrier	120
--	-----

120

Hex bolt for attaching rear axle shaft to rear axle shaft flange	1st version (M 12)	95
	2nd and 3rd version (M 8)	30

1st version (M 12)

95

2nd and 3rd version (M 8)

30

### Special tools

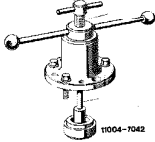
Assembly device for removal and installation of rear axle shaft on rear axle shaft flange		116 589 24 61 00
---	---	------------------

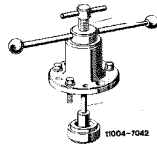

116 589 24 61 00

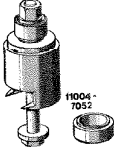
Remover and installer for rubber bearing on semi-trailing arm		116 589 13 43 00
---	--	------------------

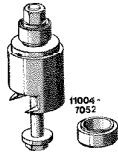

116 589 13 43 00

### Removal

- 1 Completely remove rear axle together with rear axle carrier (35-010).
- 2 Lower semi-trailing arm down to deflection stop.
- 3 Loosen hex. screw (M 12) of 1st version or hex. screw (M 8) with spacing sleeve and tensioning washer of 2nd and 3rd version for attaching rear axle shaft to rear axle shaft flange and remove.

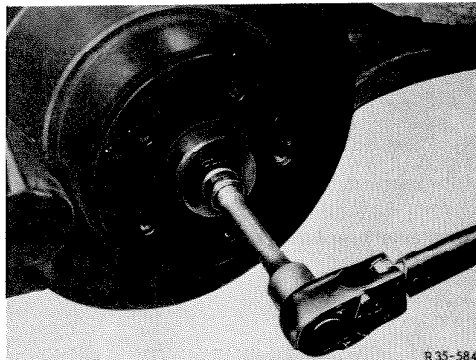

R 35-5843

## 35-110 R and R semi-trailing arm

---

4 If required, push rear axle shaft out of rear axle shaft flange by means of assembly fixture.

**Attention!**

When removing assembly tool, be sure to hold rear axle shaft in place. Do not drop rear axle shaft, so that housing for synchromesh joint will not be damaged or start leaking.

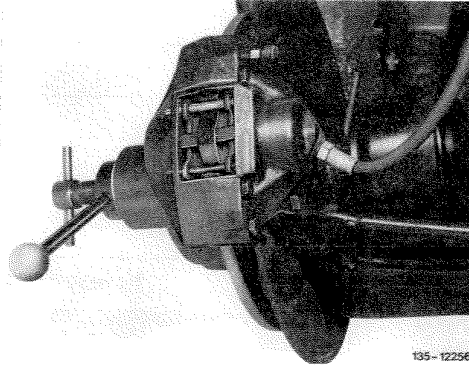

5 Loosen hex nut for attaching semi-trailing arm. Pull out hex bolts and remove semi-trailing arm.

**Attention!**

During removal and transportation of semi-trailing arm, do not damage cover plate of brake disc.

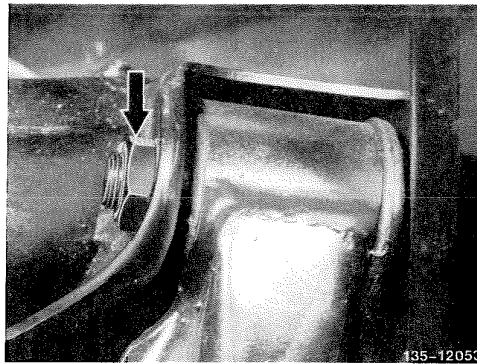

### Replacing rubber bearing

---

6 Pull rubber bearing out of semi-trailing arm.

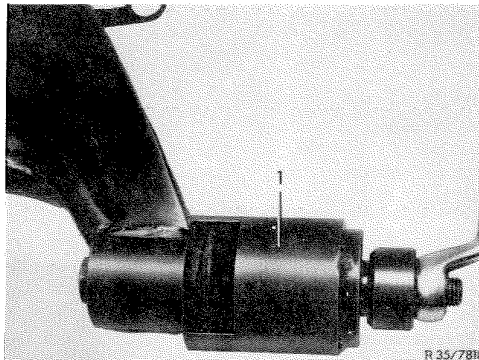

7 Coat new rubber bearing with sliding fluid and pull-in by means of installer (1) from outside in inward direction up to stop on eye of semi-trailing arm.

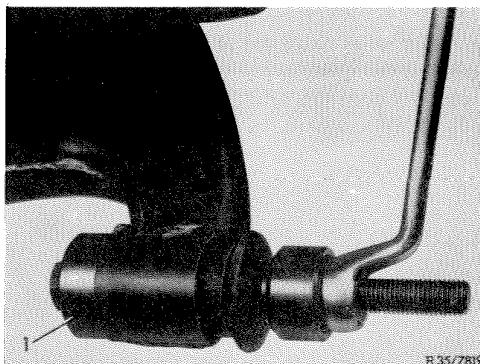

**Installation**

8 Insert semi-trailing arm into rear axle carrier. Insert hex bolts and screw-on hex nuts together with snap rings, but do not yet tighten.

9 If required, pull rear axle shaft with assembly fixture unto rear axle shaft flange.

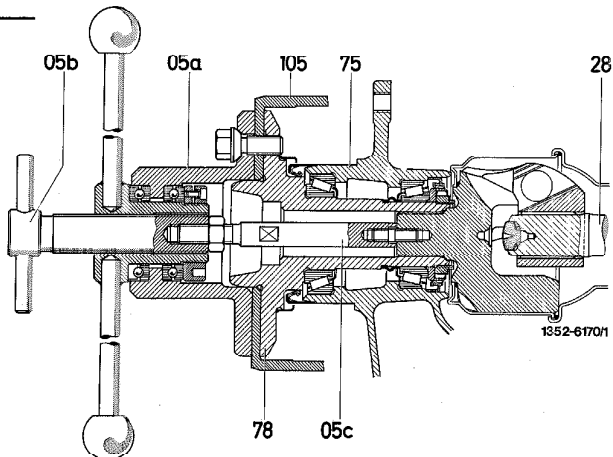

- 05a-05c Assembly fixture
- 28 Rear axle shaft
- 75 Semi-trailing arm
- 78 Rear axle shaft flange
- 105 Brake disc

10 Tighten hex. screw for attaching rear axle shaft to rear axle shaft flange on 1st version (M 12) to 95 Nm. On 2nd and 3rd version, mount hex. screw (M 8) together with tensioning washer and spacing sleeve and tighten to 30 Nm.

**Attention!**

Replace tensioning washer after one-time use. Provide tensioning washer (79a) with oil in range of screw head.

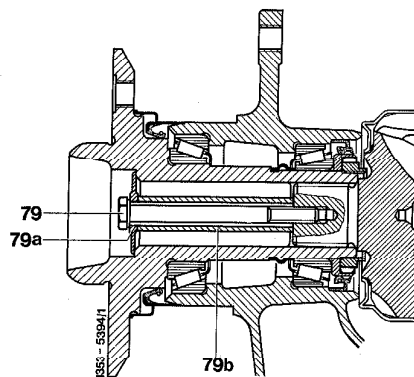

**2nd version**

- 79 Hex. screw M8 x 90
- 79a Tensioning washer
- 79b Spacing sleeve (72.5 mm long)

**Note:** Starting September 1979 the inside contour (arrow) of rear axle shaft flange has been modified and the contact surface of the tensioning washer has been moved inwards by an additional 5 mm. To guarantee the correct association of hex. screw and spacing sleeve, measure distance "a" on rear axle shaft flange from face to contact surface of tensioning washer by means of a depth gauge and take the length for the spacer sleeve and hex. screw from table.

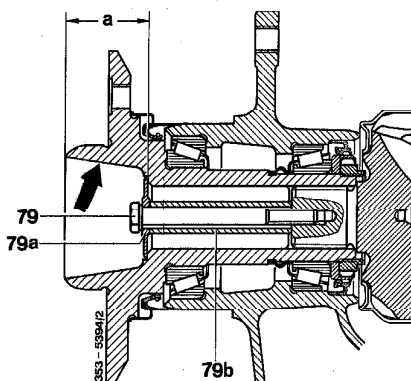

**Be sure to avoid wrong combinations!**

- 3rd version
- 79a Tensioning washer
- 79b Spacing sleeve (67.5 mm long)
- 79 Hex. screw M8 x 85
- a = 37 mm

## 35-110 R and R semi-trailing arm

---

### 2nd rear axle shaft flange version

a = 32 mm

Pertinent hex. screw = M 8x85

Pertinent spacing sleeve = 72.5 mm

### 3rd rear axle shaft version

a = 37 mm

Pertinent hex. screw = M 8x85

Pertinent spacing sleeve = 67.5 mm

As an additional external identification characteristic, the shorter hex. screw is provided with a recess on hex. head, on the shorter spacing sleeve the surface is bright, on the former sleeve it is phosphatized (bonderized).

- 11 Raise or lower semi-trailing arm until rear axle shafts are horizontal.

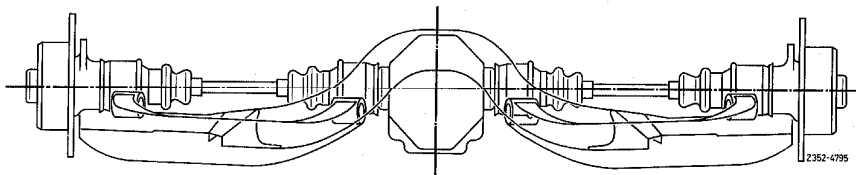

- 12 Tighten hex nuts for fastening semi-trailing arm to 120 Nm (12 kpm).

- 13 Completely install rear axle (35-010).

