



07.3–112 Testing electronic idle speed control

Job no. of flat rates or standard texts and flat rate data 07–2006.

A. Basic version

Standard

Standard KAT (open-loop)

National version   

Test data

Drive position	Coolant temperature	Idle speed
Without gear	> 42 °C	600–750/min
	< 42 °C	900–1000/min
With gear	> 42 °C	450–550/min
	< 42 °C	700–850/min
Current consumption at idle speed adjuster at operating temperature (approx. 80 °C engine oil temperature)		1050–1200 mA

Special tools

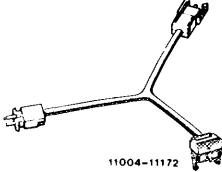
Test cable for measuring current		102 589 04 63 00
----------------------------------	-------------------------------------------------------------------------------------	------------------

Conventional tools

Digital tester (rpm, dwell angle, ignition angle)	e.g. Bosch, MOT 001.03
Multimeter	e.g. Sun DMM–5

B. Basic version NV KAT (closed-loop)
National version (J) (USA)

a) Engine 116 model year 1981/82

Test values

Coolant temperature	Idle speed
>42 °C	approx. 500/min
<42 °C	approx. 750/min

Conventional tools

Digital tester

(rpm, dwell angle, ignition angle)

e.g. Bosch, MOT 001.03

Multimeter

e.g. Sun DMM-5

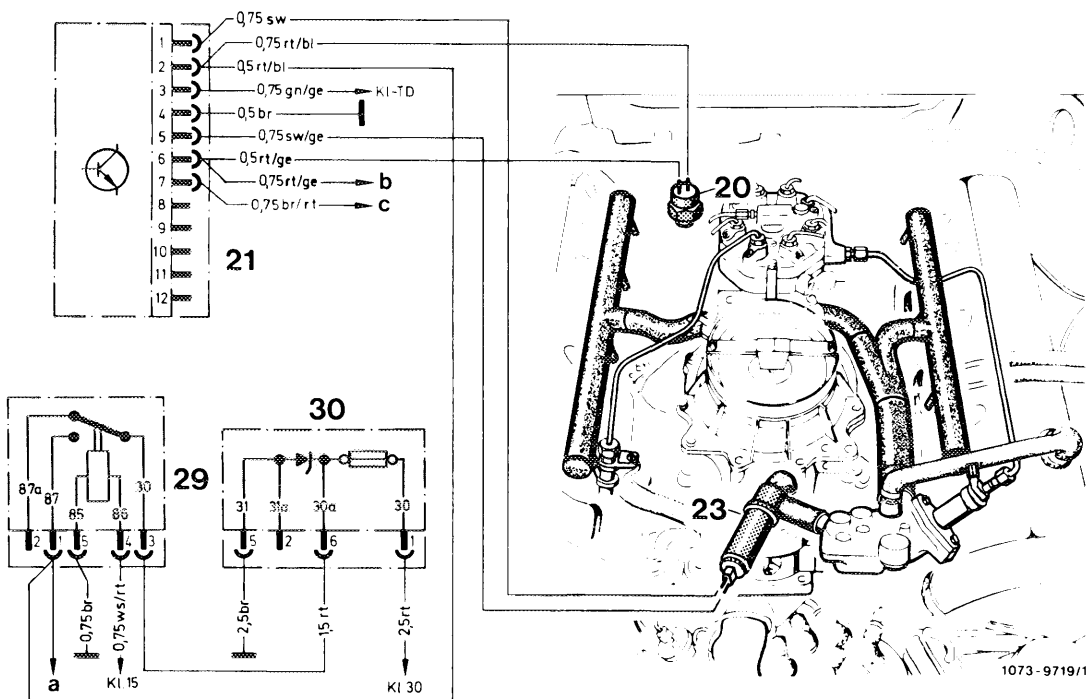

Function diagram

- 20 42 °C coolant temperature switch
- 21 Control unit, electronic idle speed control
- 23 Idle speed adjuster
- 29 Relay voltage supply
- 30 Overvoltage protection

- a To control unit lambda control, terminal 8
- b To relay air injection
- c To control unit lambda control, terminal 6,
looped on lambda control to throttle valve switch

Checking electric activation of idle speed adjuster

Engine — operating temperature.
Ignition switched on.
Pull coupling from idle speed adjuster and measure voltage.

Readout approx. 12 V	Readout 0 V.
----------------------	--------------

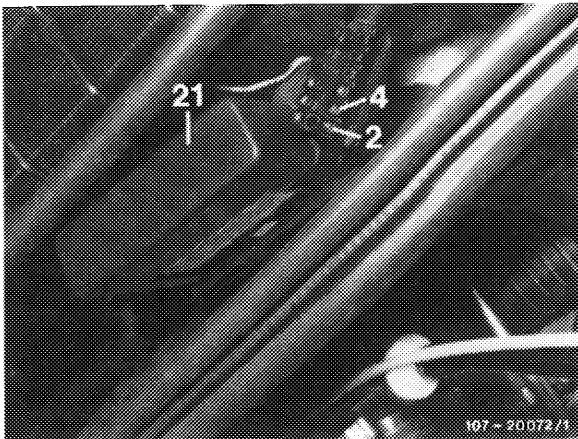
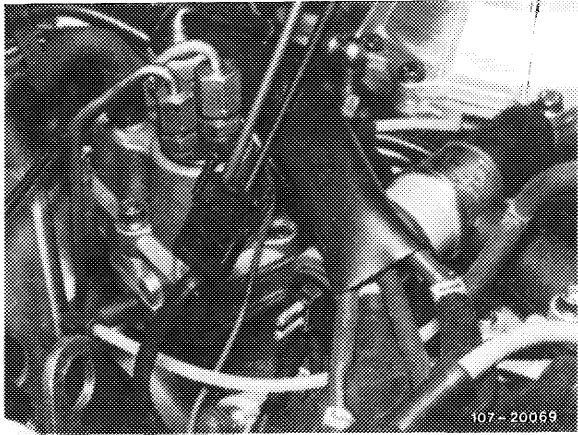

Pull coupling from control unit (21) and check voltage (approx. 12 Volts) on jacks 2 and 4.

If there is no voltage, check voltage supply according to electric wiring diagram and renew defective parts, if required.

If voltage is now available, check line (black/yellow) from coupling of control unit to coupling of idle speed adjuster for interruption and repair, if applicable.

Connect coupling to control unit and once again measure voltage on coupling of idle speed adjuster.

Readout 0 Volt, renew control unit.

End of test

Checking regulation of control unit

Engine at idle at operating temperature. Plug on coupling at idle speed adjuster in such a manner that voltage can be measured on plug.

Readout 5 Volts \pm 1.	No readout (no regulation).
--------------------------	-----------------------------

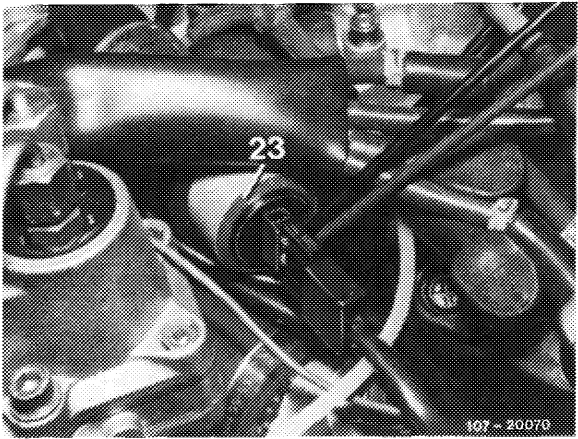

Renew control unit.

Check idle speed adjuster

Engine at idle.
Simulate coolant temperature $< 42\text{ }^{\circ}\text{C}$, for this purpose, pull coupling from temperature switch (20) and bridge.

Idle speed increases to approx. 750/min

Idle speed not increasing.

Energize idle speed adjuster with battery voltage for a short period (no more than 5 seconds).

Idle speed drops or engine stops, renew control unit.

Idle speed not dropping, renew idle speed adjuster.

End of test

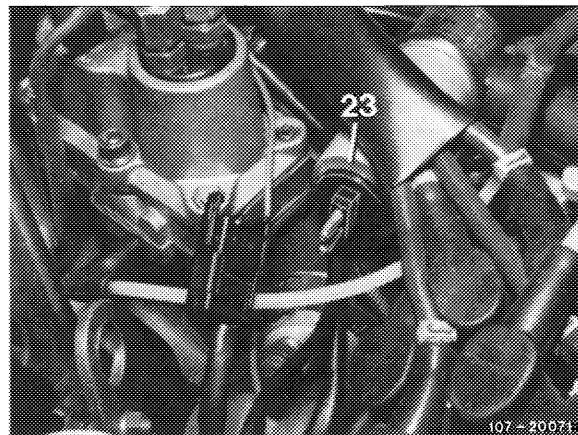
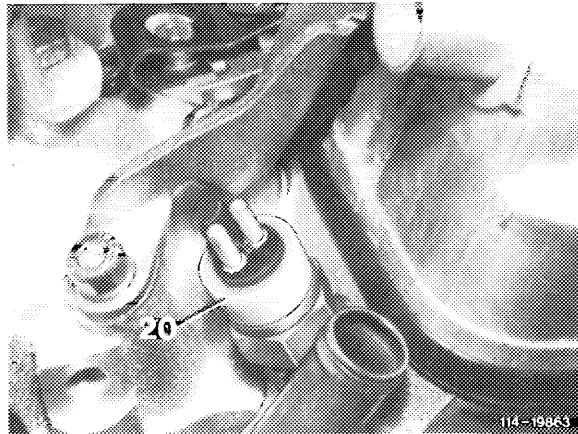

- b) Engine 116 NV KAT (closed-loop)
- Engine 116 starting model year 1983
- Engine 117 starting model year 1984

Test values

Drive position	Engine oil temperature	Idle speed
Gear stop not engaged	< 16 °C	800–950/min
	> 16 °C	600–750/min
Gear stop engaged	< 16 °C	650–750/min
	> 16 °C	450–550/min

Special tool

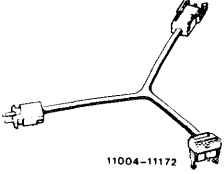
Test cable for measuring current		102 589 04 63 00
----------------------------------	------------------------------------------------------------------------------------	------------------

Conventional tools

Digital tester (rpm, dwell angle, ignition angle)	e.g. Bosch, MOT 001.03
Multimeter	e.g. Sun, DMM-5

Note

The switchover point for engine speed is tapped at the 16 °C oil temperature switch (19), which at the same time supplies a signal to the control unit of the lambda control.

It is not possible to fit the control unit from former model years.

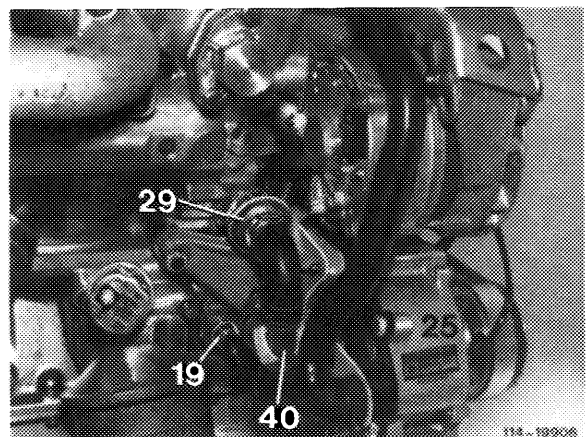

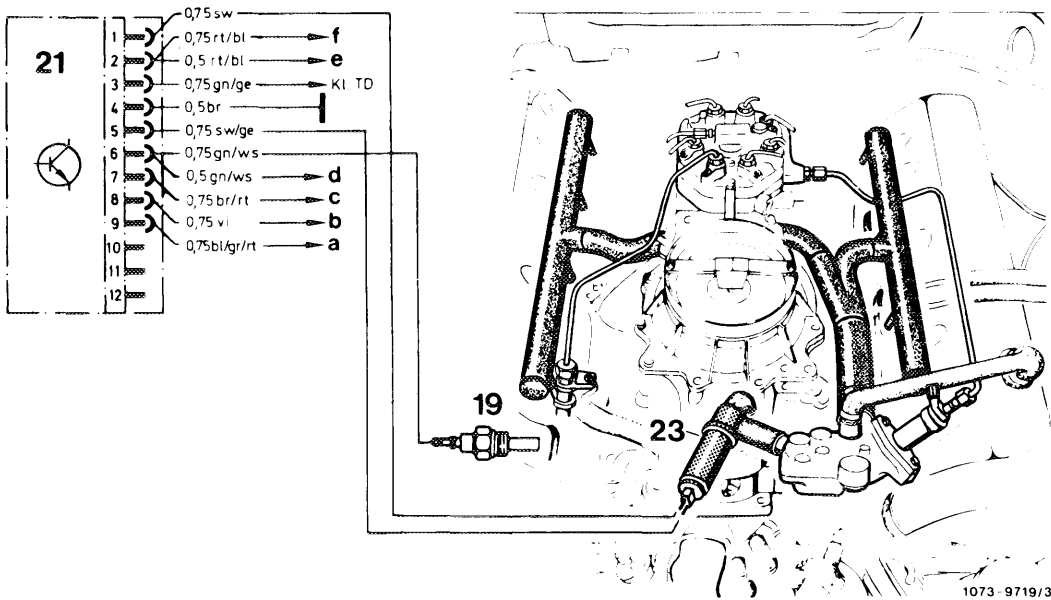

Function diagram

- 19 16 °C oil temperature switch
- 21 Control unit, electronic idle speed control
- 23 Idle speed adjuster

- a To lug (a) automatic climate control
- b To ignition starter switch terminal 50
- c To control unit lambda control terminal 6, looped on lambda control to throttle valve switch

- d To control unit lambda control terminal 7
- e To relay overvoltage protection
- f To 42 °C coolant temperature switch

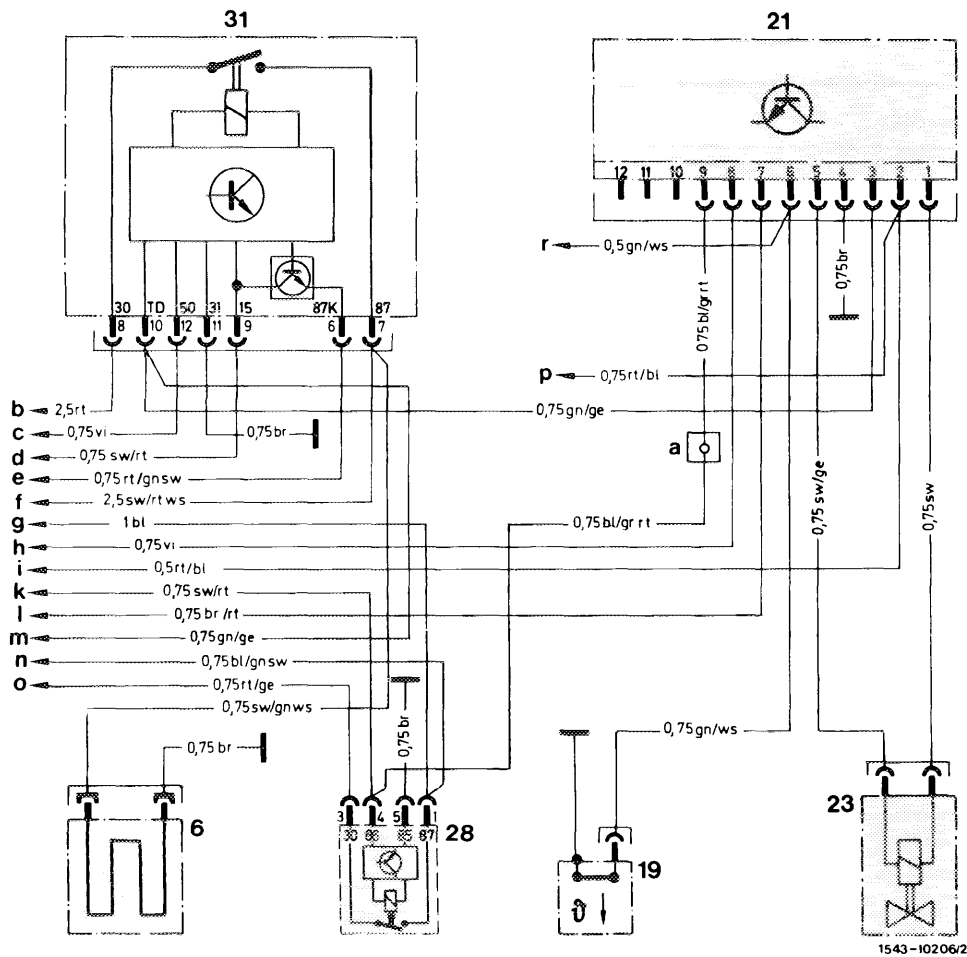

Electric wiring diagram idle speed control

- 6 Warm-up compensator
- 19 16 °C oil temperature switch
- 21 Control unit, electronic idle speed control
- 23 Idle speed adjuster
- 28 Relay air conditioning or automatic climate control
- 31 Fuel pump relay

- a Lug air conditioning or automatic climate control
- b To lug terminal 30, model 126
To cable connector engine, terminal 30, model 107
- c To cable connector engine, terminal 50
- d To fuse box terminal 15

- e To starter lockout and backup light switch, terminal 7
- f To tail lamp harness terminal 2
- g To coupling of refrigerant compressor
- h To ignition starter switch terminal 50
- i To relay lambda control with overvoltage protection, terminal 2
- k To low pressure switch refrigerant compressor
- l To control unit lambda control terminal 6
- m To cable connector terminal TD, model 126
To revolution counter, model 107
- n To switching unit temperature control
- o To fuse box terminal 15 X
- p To 42 °C coolant temperature switch
- r To control unit lambda control terminal 7

Cable colour coding
 bl = blue
 br = brown
 ge = yellow
 gn = green
 gr = grey
 rt = red
 sw = black
 vi = purple
 ws = white

Idle speed adjuster

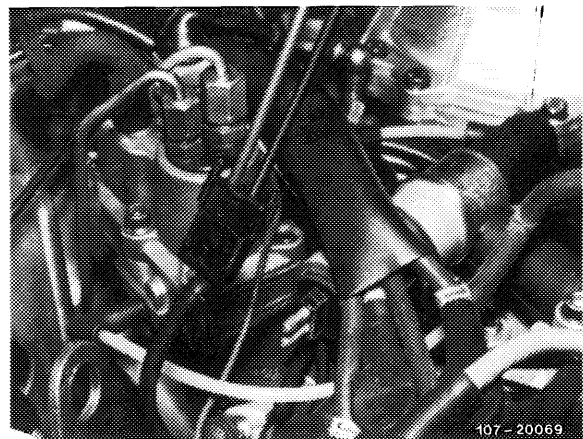
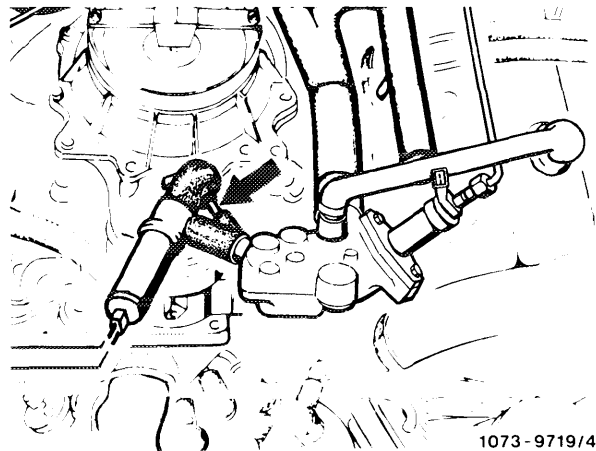
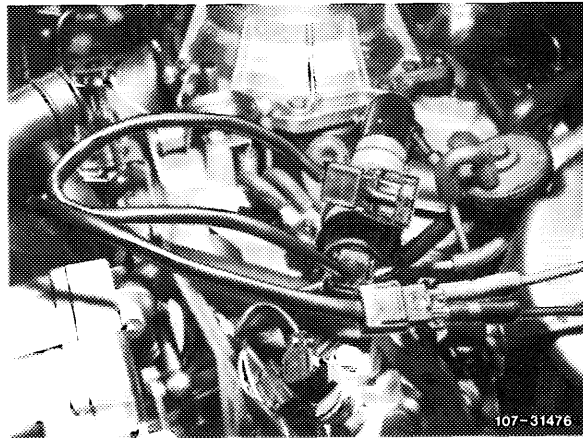
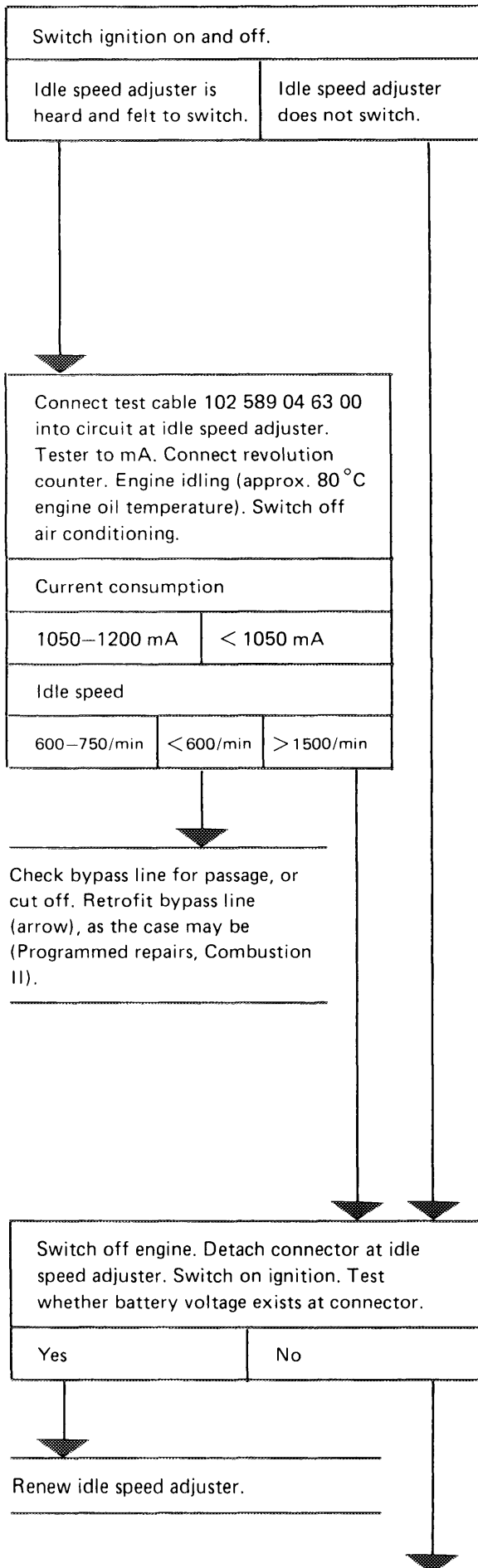

Detach connector at control unit (21). Switch on ignition. Test whether battery voltage exists at contact 2 (positive) and 4 (ground)

If no voltage exists:

- a) Test black/red cable between contact 2 and fuse 14 (terminal 15).
- b) Test brown cable, contact 4, to ground (refer to wiring diagram).

If voltage exists:

Briefly jumper contacts 1 and 2 and 4 and 5 simultaneously (max. 5 seconds). Idle speed adjuster must be heard to switch.

Idle speed adjuster switches.

Idle speed adjuster does not switch.

Check contour hoses for passage.
Renew control unit.

Test cables (contacts 1 and 5) between idle speed adjuster and control unit for continuity.

Resistance approx. 0 Ω.

Yes

No

Rectify cable interrupt according to wiring diagram.

- 21 Control unit, electronic idle speed control
- 23 Idle speed adjuster
- h Fuse box terminal 15 fuse 14

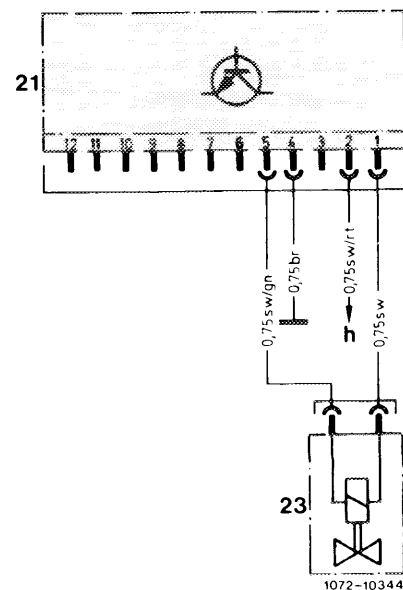
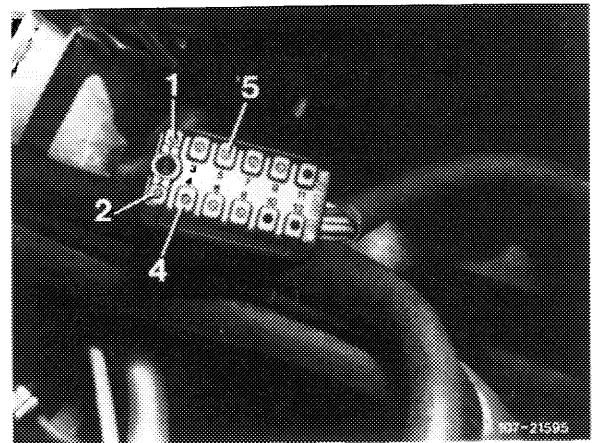
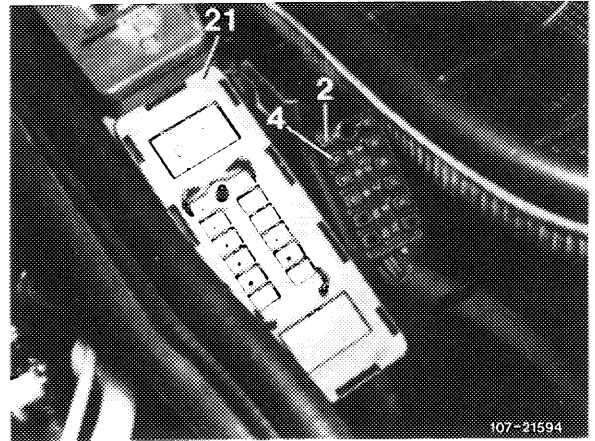

Check green/yellow TD cable from fuel pump relay to control unit for continuity.	
Resistance 0 Ω	
Yes	No

Rectify cable interrupt according to wiring diagram.

Additional functions
Test cutin signal of automatic transmission and air conditioning compressor.

Idle speed with and without drive position

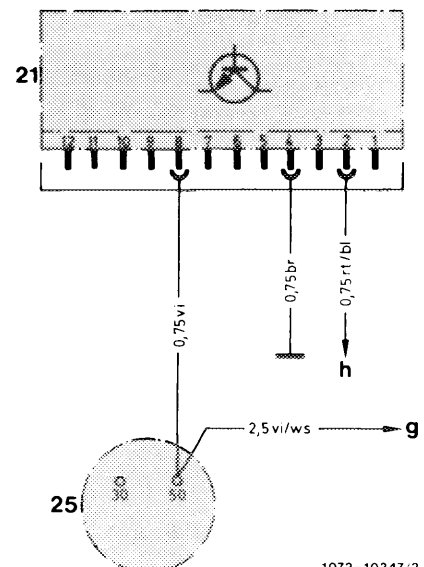
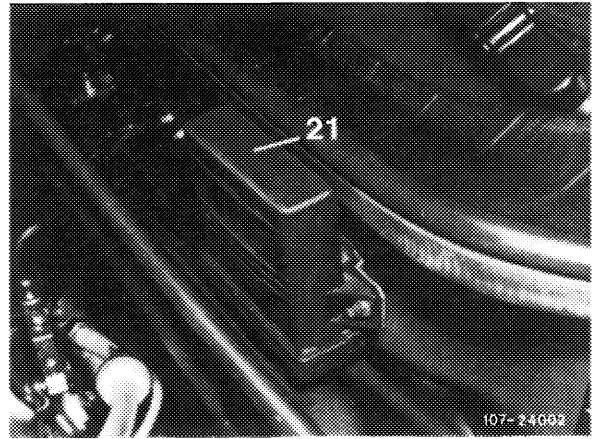
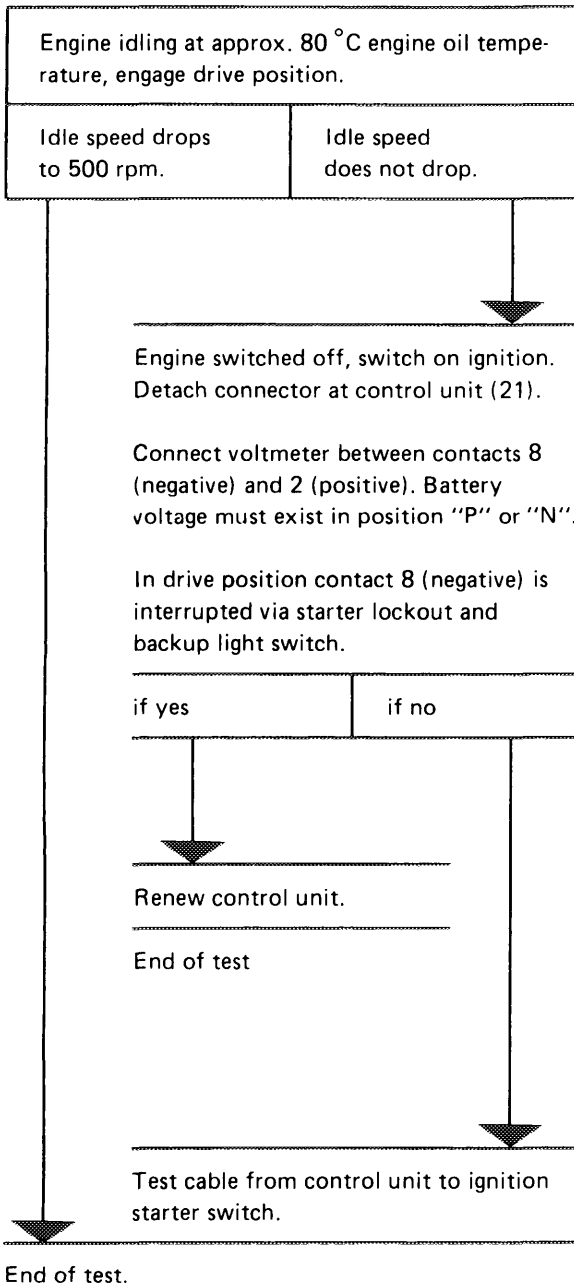

- 21 Control unit, electronic idle speed control
- 25 Ignition starter switch
- g Starter lockout and backup light switch
- h Fuse box terminal 15 input terminal 14

1072-10347/2

Idle speed stabilization on engines with refrigerant compressor

Engine idling at approx. 80 °C engine oil temperature. Switch on refrigerant compressor. Sharp drop in speed.

Yes	No
-----	----

End of test

Switch off engine. Switch on ignition. Detach connector at control unit. Battery voltage must exist at contact 9 (positive).

Battery voltage yes	Battery voltage no
---------------------	--------------------

Renew delay relay (arrow) or control unit.

Test voltage supply according to wiring diagram.

End of test

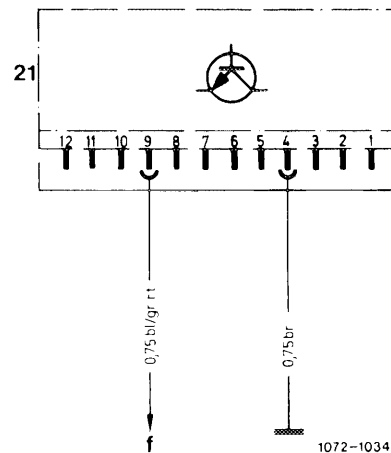
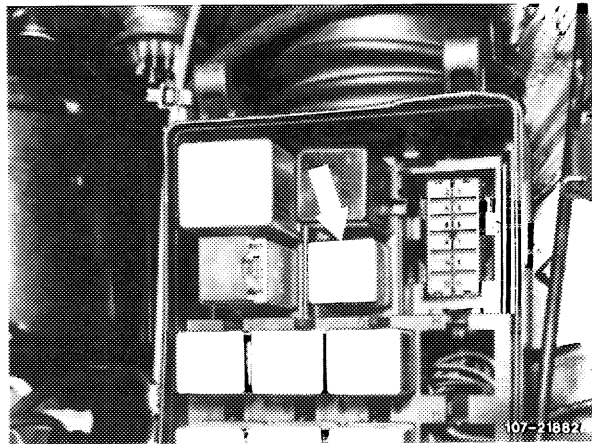

- 21 Control unit, electronic idle speed control
- f Lug, air conditioning in fuse box

C. Idle speed and partial load identification

a) Vehicles with vacuum switch

Pull coupling (arrow) on vacuum switch (22) and bridge.

Idle speed 600–750/min.

Yes	No
-----	----

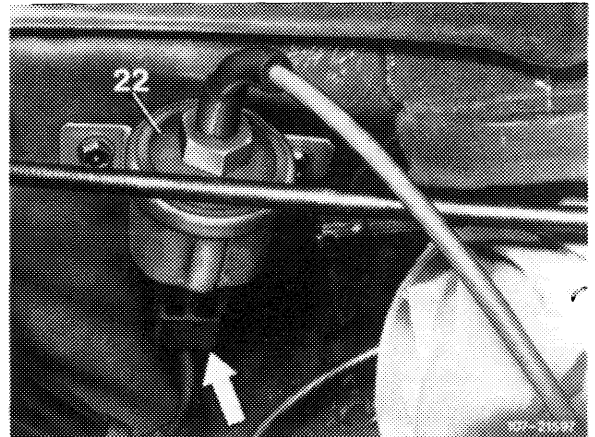

Check coupling on vacuum switch and on control unit (21) according to wiring diagram.

Battery voltage	Battery voltage
Yes	No

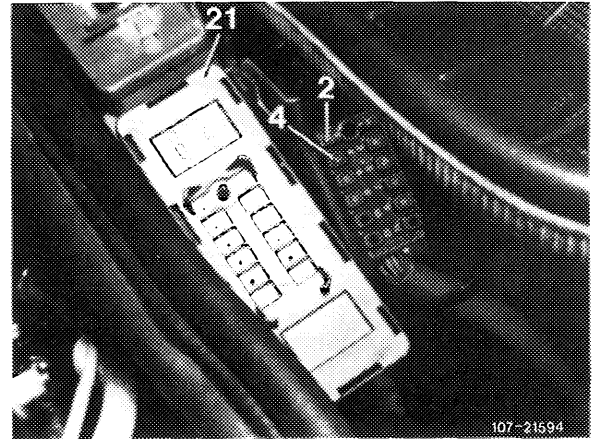

Renew control unit.	Check voltage supply according to wiring diagram.
---------------------	---------------------------------------------------

End of test

Plug on coupling at vacuum switch.
Energize vacuum switch with approx. 500 mbar.

Rpm increase by approx. 200/min.	No rpm increase.
----------------------------------	------------------

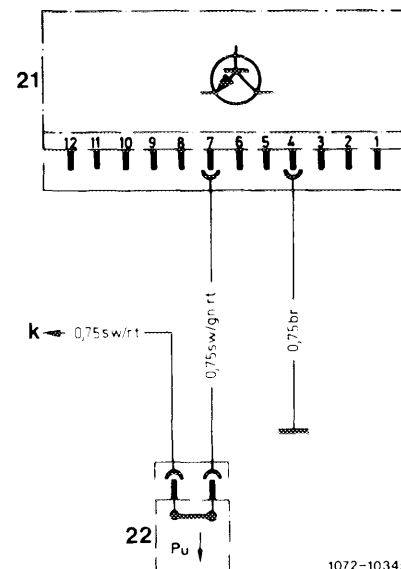

- 21 Control unit electronic idle speed control
- 22 Vacuum switch
- k Fuse box terminal 15 fuse 12

1072-10345

Renew vacuum switch.

End of test

At slight acceleration, vacuum should be immediately established at white/yellow line.

Yes

No

End of test

Check white/yellow line and connection on throttle valve housing for passage. Possible mixup with EGR at throttle valve housing.

End of test

a EGR
b Vacuum switch

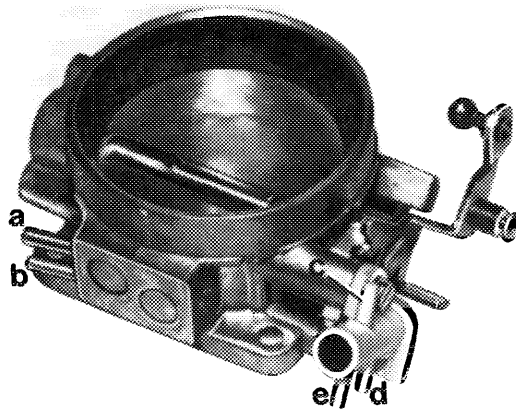

107-21700

b) Vehicles with throttle valve switch

Switch off engine.
Pull off coupling (arrow) between throttle valve switch and control unit.

Test resistance of throttle valve switch. Adjust throttle valve switch or renew or poles wrongly connected (see 07.3-152).

Throttle valve switch in order

Yes

No

Renew throttle valve switch.

Test cables between throttle valve switch and control unit for interruption according to wiring diagram.

End of test

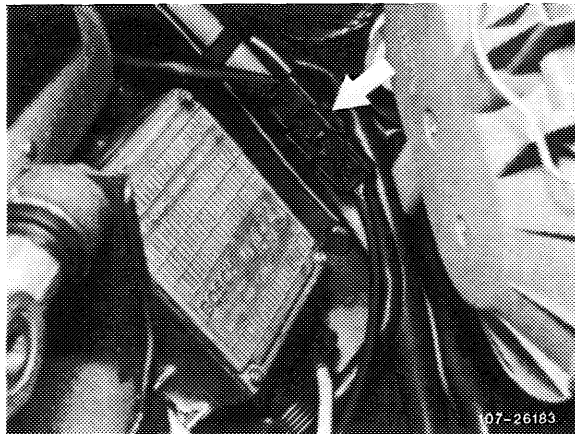

107-26183

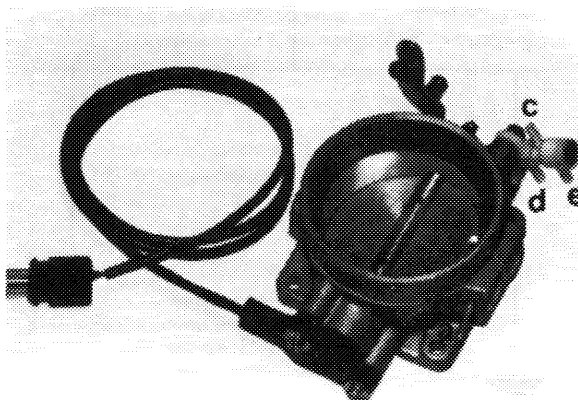

107-25806

D. Idle speed increase when engine cold

a) Vehicles with 42 °C coolant temperature switch

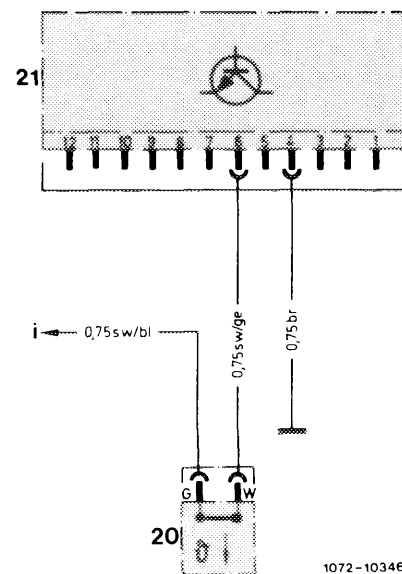
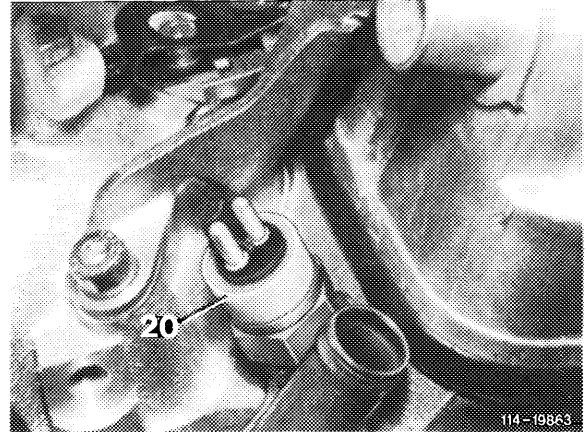
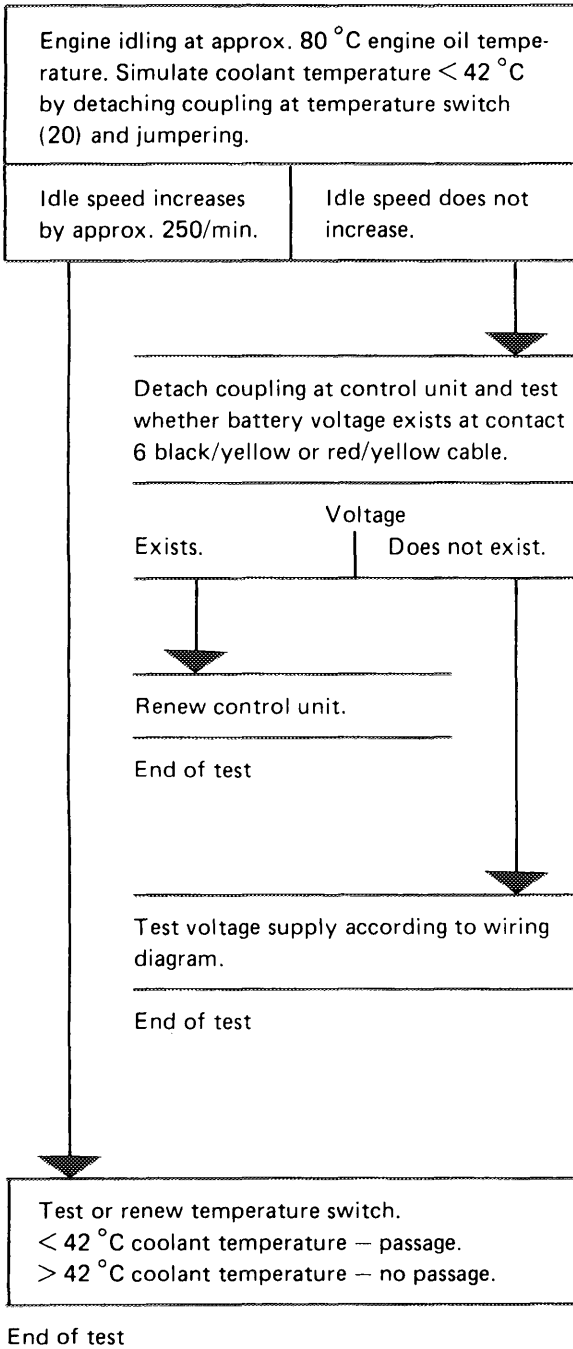

- 20 42 °C coolant temperature switch
- 21 Control unit, electronic idle speed control
- i Fuse box terminal 15 fuse 12

1072-10346

b) Vehicles with 16 °C oil temperature switch

Engine at idle and engine oil temperature approx. 80 °C. Selector lever in position "P" or "N". Simulate engine temperature < 16 °C. For this purpose, pull coupling from temperature switch (19) and connect to ground.

Idle speed increasing to 800–900/min.

Idle speed not increasing.

Pull coupling from control unit and check line from jack 6 to temperature switch 16 °C oil for passage.

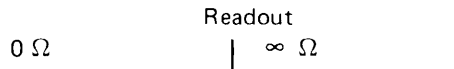

Renew control unit.

End of test

Check line to temperature switch.

End of test

Check temperature switch or renew.
 < 16 °C engine oil temperature – passage.
 > 16 °C engine oil temperature – no passage.

End of test

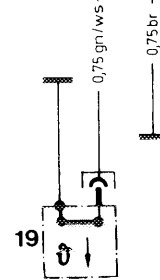
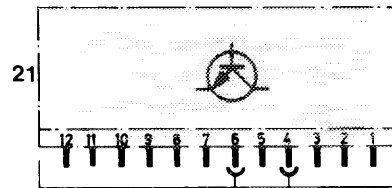
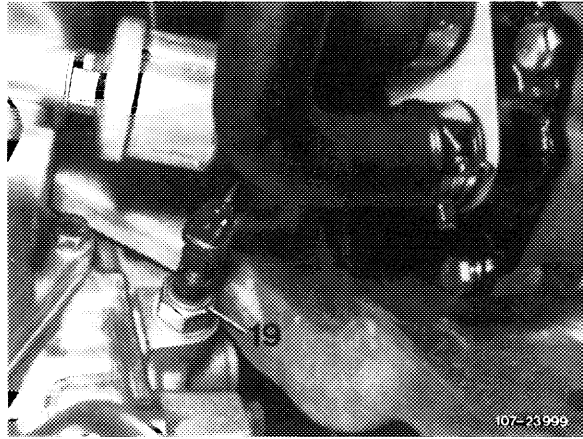

1072-10346/1

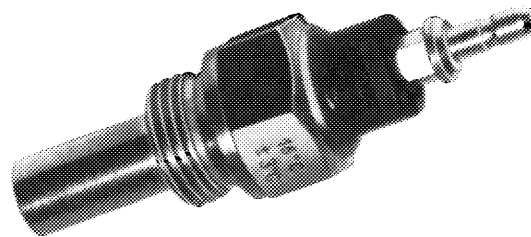

E. Idle speed on warm engine too high

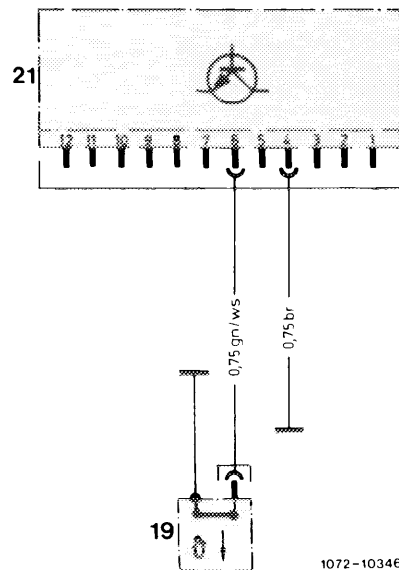
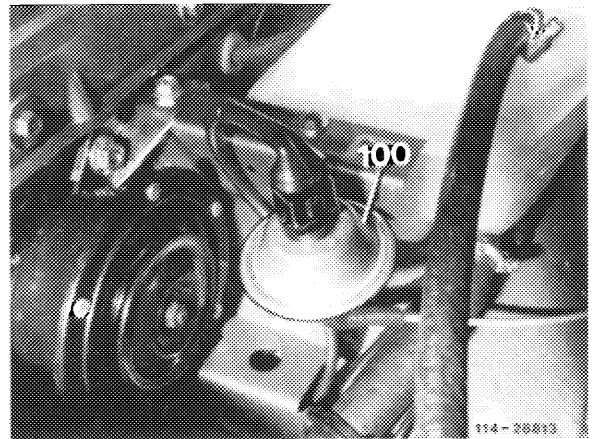
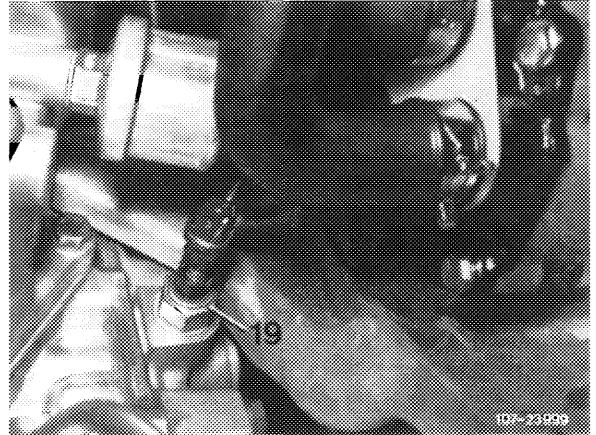
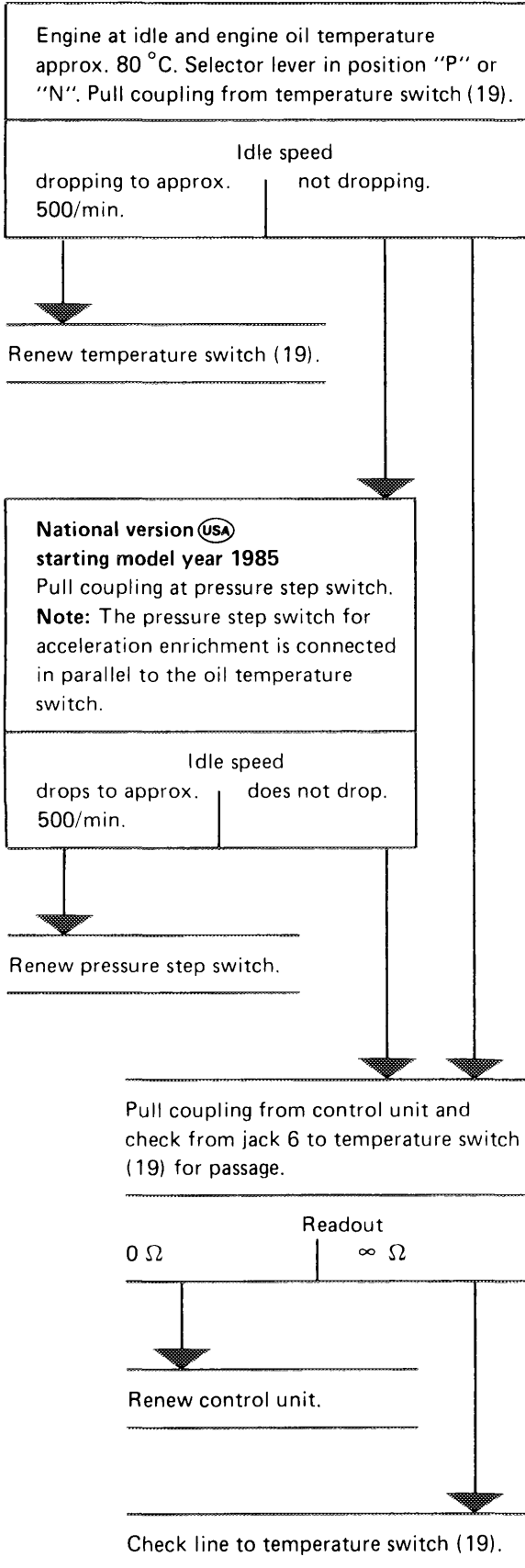

End of test

F. Assignment of auxiliary functions

Version	Idle speed and part load identification		Idle speed increase when engine cold by	
	Vacuum switch	Throttle valve switch	42 °C coolant temperature switch	16 °C oil temperature switch
Basic version starting September 1981 to April 1983 Standard Standard KAT (open-loop)	X	—	X	—
Basic version starting may 1983 Standard Standard KAT (open-loop) National version (AUS) (CH) (S) starting model year 1984	—	X	X	—
National version (J) (USA) Engine 116, model year 1981/82	—	X	X	—
National version (J) (USA) Engine 116 starting model year 1983 Engine 117 starting model year 1984 Basic version NV KAT (closed-loop)	—	X	—	X