

83–526 Removal and installation of electromagnetic clutch





B. Delco refrigerant compressor (engine 116 and 117)

Data

Designation	electromagnetic shutoff clutch 12 V, Frigidaire 5 inch
Power input in amps at 13.5 V	cold 3.0 warm 2.5

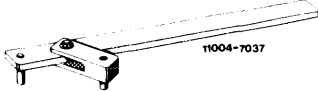
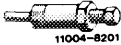
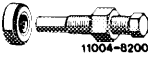
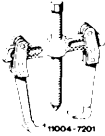
Tightening torque	Nm
Counter nut to shaft	20

Special tools

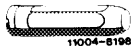
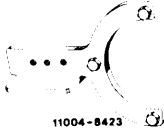
Special wrench for counterholding spring plate		116 589 10 07 00
Remover for spring plate		000 589 07 35 00
Installer for spring plate		000 589 49 43 00
Puller		000 589 88 33 00
Thrust piece for puller		116 589 05 63 00
Mandrel for pulley		115 589 02 35 02
Remover and installer for slip ring		000 589 21 61 00
Remover and installer for shaft sealing ring		000 589 65 63 00
Holding device for refrigerant compressor		109 589 00 31 00

Conventional tools

Slip gauges 0.05–1.00 mm	order no. 2147	
Pliers for internal lock	order no. 1846b–2	e.g. made by Hazet D-5630 Remscheid 1
Pliers for external lock	order no. 1846d–2	

Note

Removal and installation of spring plate with pulley and clutch coil, as well as of shaft seal, can be performed only with refrigerant compressor removed.

a) Spring plate

Removal

- 1 Drain air-conditioning system (83–516).
- 2 Remove refrigerant compressor (83–522).
- 3 Clamp refrigerant compressor with refrigerant compressor carrier into vice, without refrigerant compressor carrier into holding device for refrigerant compressor.
- 4 Prevent turning of spring plate (4) by means of holding tool (2), then unscrew counter nut from shaft using 14-mm socket.

Unscrewing of counter nut from shaft end

- | | |
|--------------------------|----------------|
| 1 Refrigerant compressor | 3 Socket |
| 2 Holding tool | 4 Spring plate |

- 5 Screw remover (2) into hub. Hold tool in position with wrench and tighten center screw.
- 6 Remove key from shaft.

Removing spring plate

- | | |
|--------------------------|----------------|
| 1 Refrigerant compressor | 3 Spring plate |
| 2 Remover | |

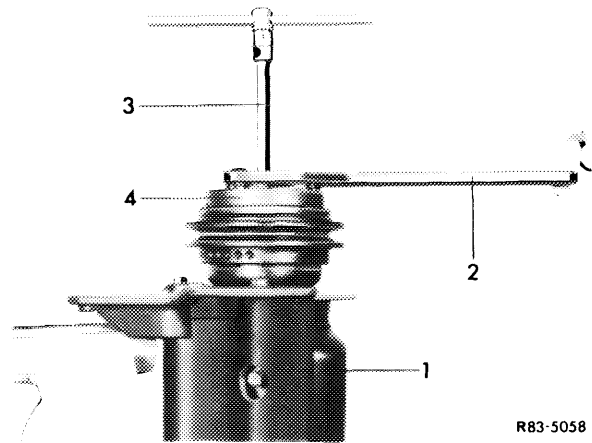

R83-5058

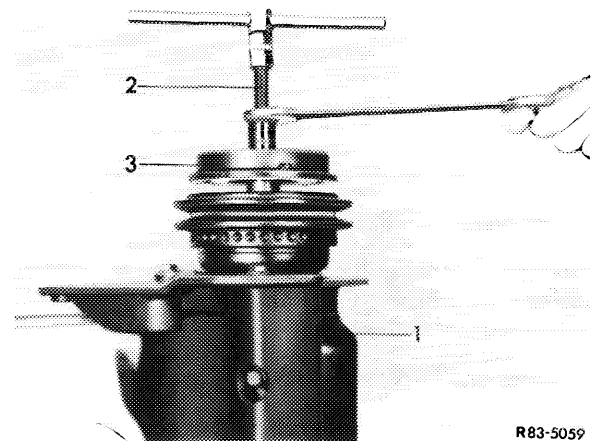

R83-5059

Installation

- 7 Insert key into shaft.
- 8 Clean friction surface of spring plate and pulley.
- 9 Place spring plate on shaft with key and keyway in alignment.

Attention!

To prevent damaging parts inside compressor, do not knock on or against spring plate or shaft.

10 Place spacer (2) on spring plate (1). Insert installer (3) through spacer (2) and screw installer (3) to shaft end.

11 Hold hex. head of tool and screw center screw down by several turns to press spring plate partially on shaft.

Installing spring plate

- 1 Spring plate 3 Installer
- 2 Spacer

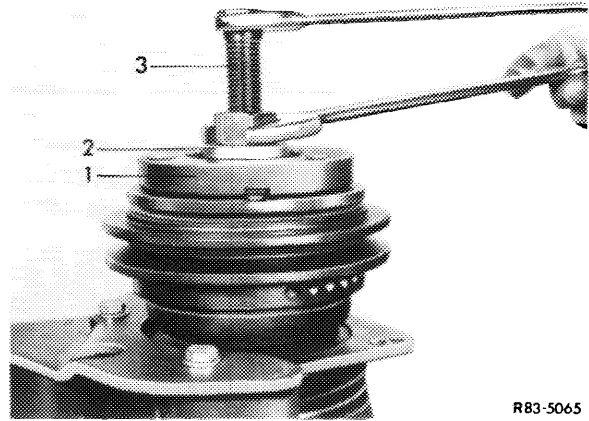

R83-5065

12 Remove installer (3) and spacer (2), check key and keyway for alignment. If both are correctly aligned, mount installer again and continue pressing spring plate (1) against shaft until the distance between the friction surfaces of the pulley and the spring plate amounts to approx. 1 mm to 1.5 mm.

13 Remove installer (3) and spacer (2).

Sectional view of shaft seal and sealing seat

- 1 Shaft
- 2 Hub
- 3 Collar nut
- 5 Holding ring
- 7 Key
- 8 Felt ring
- 9 Locking ring
- 10 Ceramic ring
- 11 O-ring
- 12 Shaft seal
- 13 Front head member

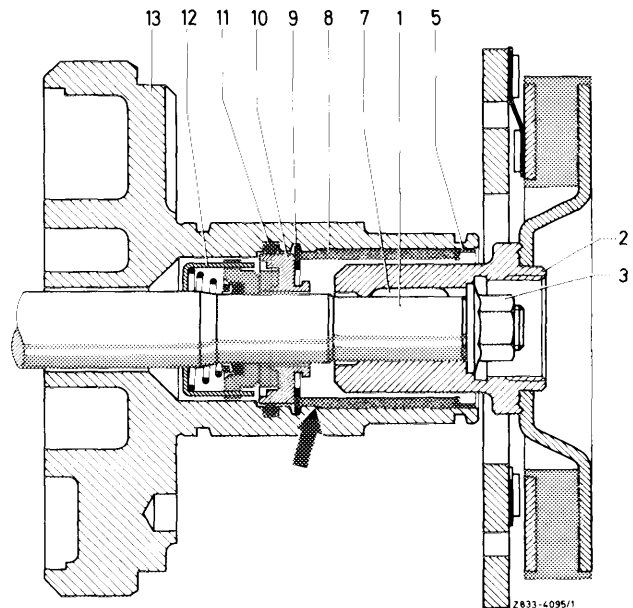

14 Screw-on new collar nut (3) with shoulder (smaller dia. of nut) in direction of shaft. Hold spring plate in position with holding tool (2) and tighten counter nut. The distance between the two friction surfaces of pulley and spring plate should now amount to approx. 0.5 to 1.5 mm.

15 Install refrigerant compressor (83-522).

Checking distance between spring plate and pulley

- 1 Spring plate
- 2 Pulley

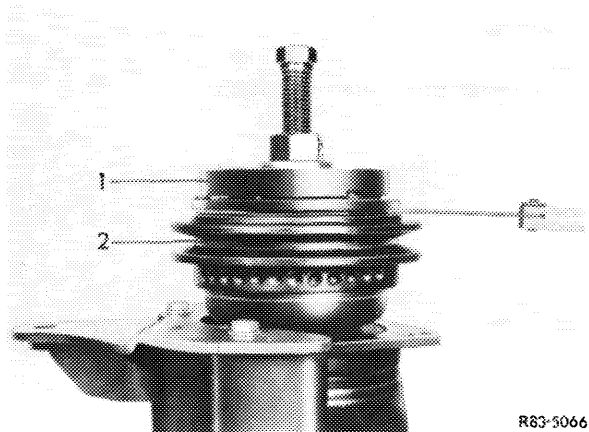

R83-5066

b) Pulley

Removal

- 1 Remove spring plate (section a item 1 to 6).
- 2 Remove locking ring (2) and holding ring (5).

Removing locking ring for pulley

1 Pulley 2 Locking ring

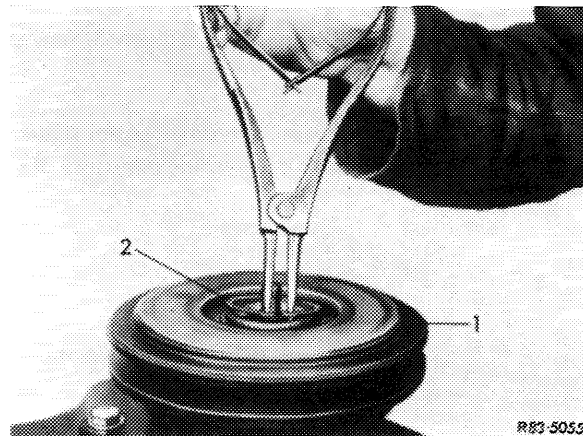

- 3 Insert guide member (2) into bore in head section of compressor.

- 4 Pull-off pulley (1) with puller (3).

Removal of pulley

1 Pulley 2 Guide member

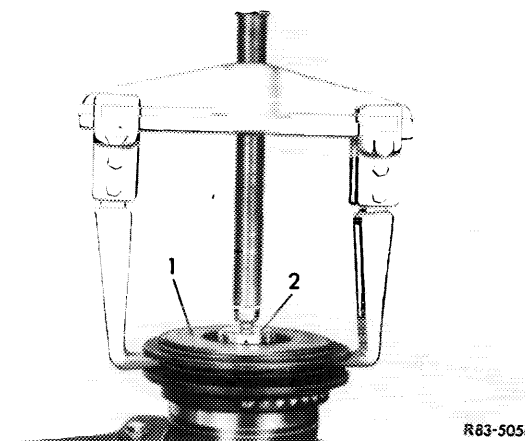

Installation

- 5 If the same pulley is installed again, clean friction surface of pulley. If friction surface shows evidence of damage, e.g. caused by overheating, replace pulley together with spring plate.

- 6 Knock pulley (1) with assistance of mandrel (2) on guide pin of refrigerant compressor. Position mandrel in such a manner that the respective forces are directed against inner race of bearing, so that any damage to bearing will be prevented.

- 7 Check pulley for unobstructed operation. Then insert locking ring (2) with flat side facing downwards.

- 8 Install spring plate (section a).

Removal of locking ring for pulley

1 Pulley 2 Mandrel

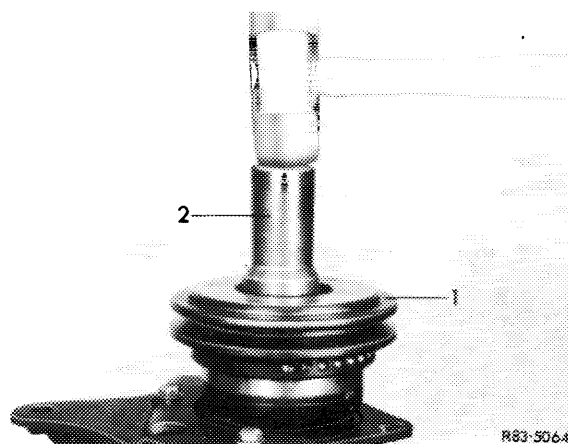

c) Clutch coil

Removal

- 1 Remove spring plate and pulley (section a and b).
- 2 Mark location of electric connections on coil housing on front head section of refrigerant compressor.
- 3 Remove locking ring (3).
- 4 Lift clutch coil (2) from refrigerant compressor (1).

Installation

- 5 Insert clutch coil (2) on front head section of refrigerant compressor in such a manner that the electric connections are in alignment with applied marks.

Removal and installation of clutch coil

- 1 Refrigerant compressor
- 2 Clutch coil
- 3 Locking ring

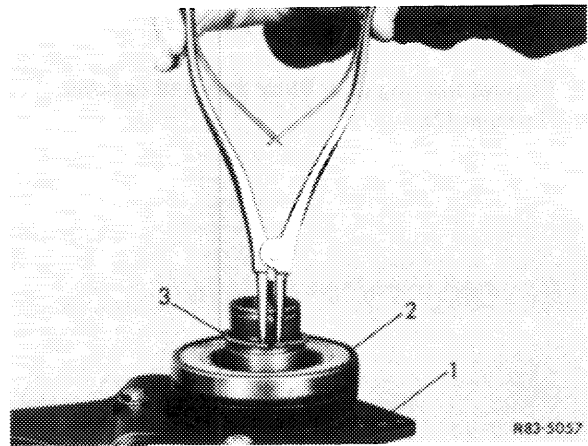

- 6 Align guide pins below on coil housing with holes in front head section of refrigerant compressor.
- 7 Install locking ring (3) with flat side of ring in direction of coil.
- 8 Install pulley and spring plate (section a and b).

d) Shaft seal of refrigerant compressor

Removal

- 1 Remove spring plate (section a).

Note: Removal of pulley and clutch coil when removing and installing shaft seal is not required.

- 2 Remove holding ring (5) and felt ring (8).

Section: Shaft seal and sealing seat

- | | |
|----------------|----------------------|
| 1 Shaft | 8 Felt ring |
| 2 Hub | 9 Locking ring |
| 3 Collar nut | 10 Ceramic ring |
| 5 Holding ring | 11 O-ring |
| 7 Key | 12 Shaft seal |
| | 13 Front head member |

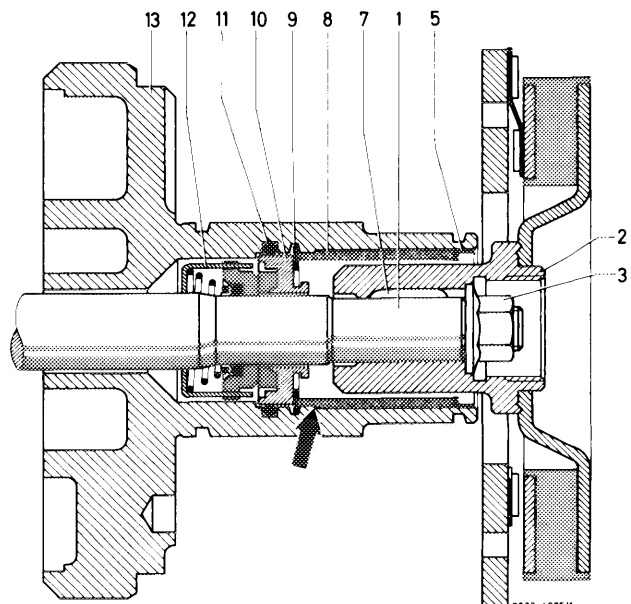

Note: Puller is self-made of 2.5 mm dia. brass wire.

Removal of holding ring
5 Holding ring

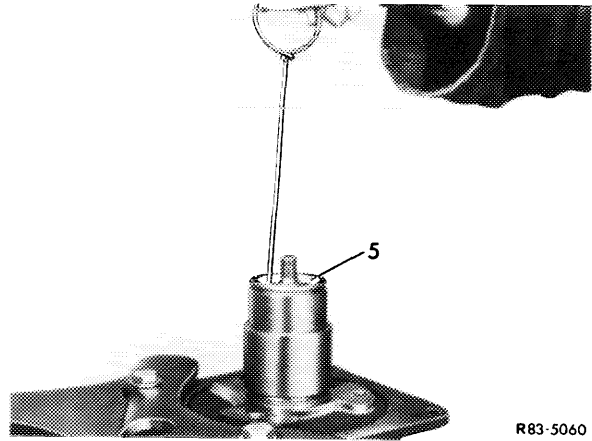

R83-5060

- 3 Remove locking ring (9) for shaft seal.
- 4 Remove slip ring (3 or 9) by means of remover and installer (2).

Removal of locking ring for shaft seal
9 Locking ring

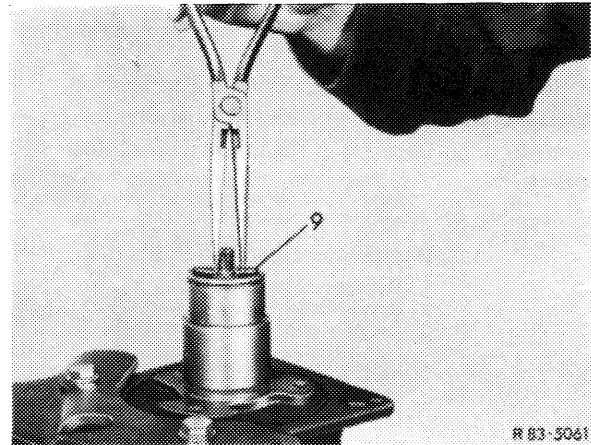

R 83-5061

Removal of ceramic slip ring
1 Refrigerant compressor
2 Remover and installer
3 Slip ring

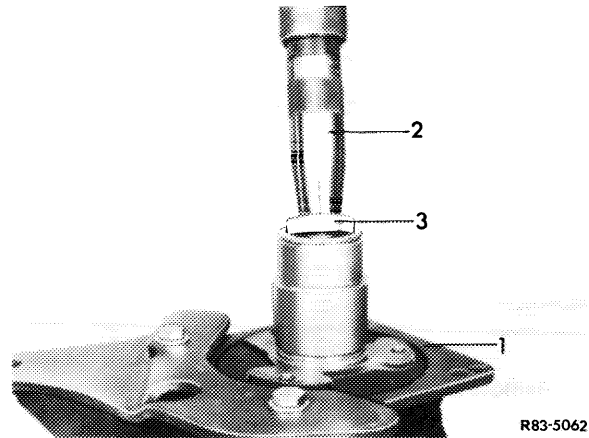

R83-5062

- 5 Remove shaft seal (2 or 11) with assistance of tool (3). For this purpose, push down on tool, turn tool to the right to engage lugs of shaft seal and locking tongues on tool. Remove complete shaft seal by straight pulling from shaft.

Removal of shaft seal
1 Refrigerant compressor
2 Shaft seal
3 Remover and installer

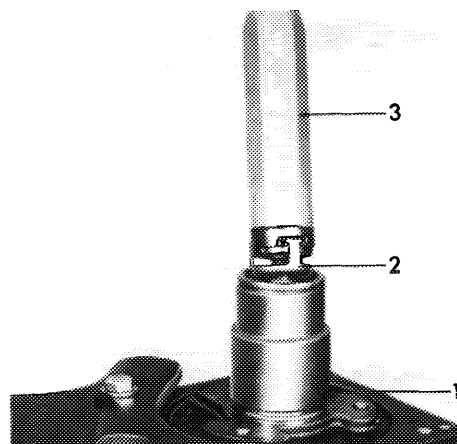

R83-5063

6 Remove O-ring (11) from inside bore in front head section of refrigerant compressor. A wire, which has been bent to a hook, may be used.

Installation

7 Check whether parts of the old seal are still in bore of front head section. Clean bore prior to inserting a new seal.

8 Insert new O-ring (11) into groove of bore in head section (13), making sure that the sealing ring is inserted in lower groove.

Section: Shaft seal and sealing seat

- | | |
|----------------|----------------------|
| 1 Shaft | 9 Locking ring |
| 2 Hub | 10 Ceramic ring |
| 3 Collar nut | 11 O-ring |
| 5 Holding ring | 12 Shaft seal |
| 7 Key | 13 Front head member |
| 8 Felt ring | |

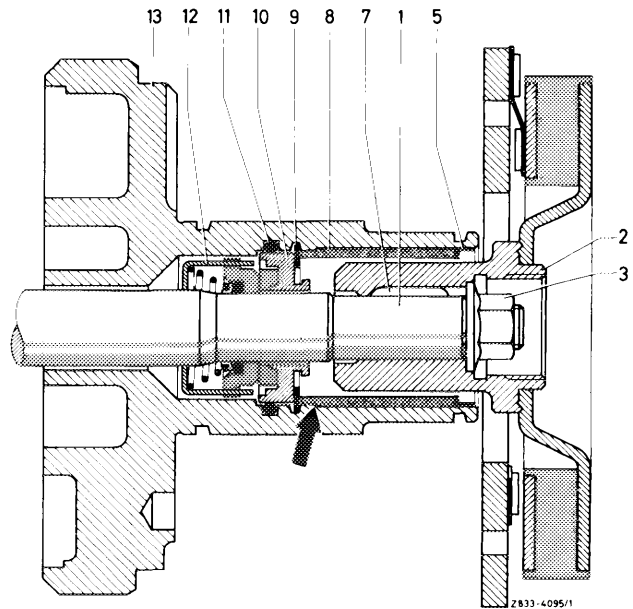

9 Provide shaft seal (11) with refrigerant oil prior to installation to prevent damaging seal during installation.

10 Insert shaft seal (2 or 12) into tool (3) and slip on shaft in compressor. Keep turning tool to the right until shaft seal engages in shaft. Only then turn tool to the left for disengagement from lugs of shaft seal and remove.

Installation of shaft seal

- | |
|--------------------------|
| 1 Refrigerant compressor |
| 2 Shaft seal |
| 3 Remover and installer |

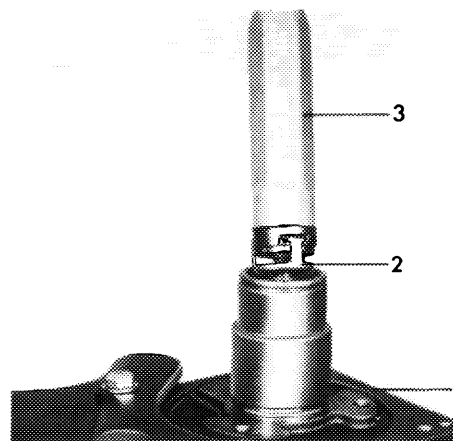

R83-5063

11 Introduce slip ring (3 or 10) with assistance of tool (2) into bore of front head section until slip ring touches shaft seal. Make sure that the O-ring (11) is not pushed out of groove.

Installation of ceramic slip ring

- 1 Refrigerant compressor
- 2 Remover and installer
- 3 Slip ring

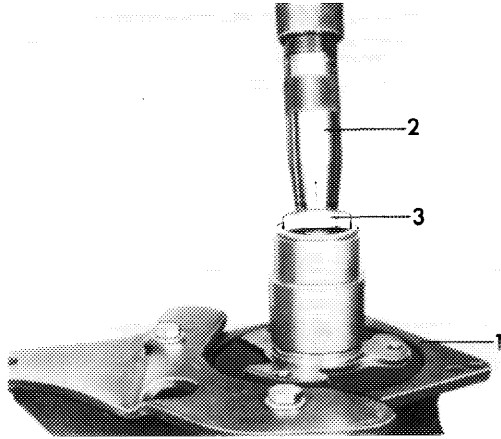

R83-5062

Attention!

Protect sealing surface of slip ring against any kind of damage such as scratches.

12 Introduce locking ring (9) with flat side in downward direction into bore until locking ring rests on slip ring. Then push with circlip pliers or a screw driver on locking ring until locking ring snaps into groove.

Installation of locking ring for shaft seal

- 9 Locking ring

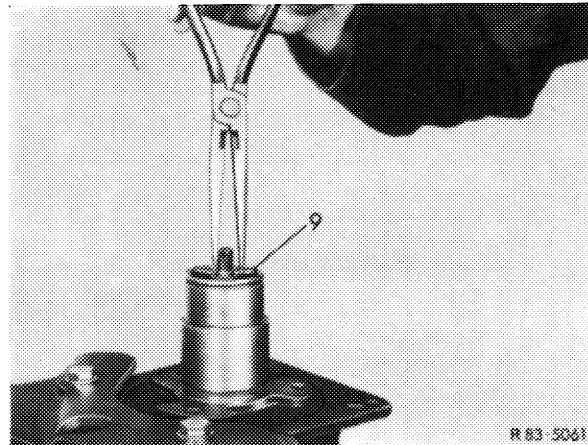

R 83-5061

Note: The shoulder (refer to arrow) seen from end of bore is a projection and not a groove.

13 Install spring plate (section a).

14 Check oil level in refrigerant compressor (83-520).

15 Check compressor for leaks (83-525).

Section: Shaft seal and sealing seat

- | | |
|----------------|----------------------|
| 1 Shaft | 9 Locking ring |
| 2 Hub | 10 Ceramic ring |
| 3 Collar nut | 11 O-ring |
| 5 Holding ring | 12 Shaft seal |
| 7 Key | 13 Front head member |
| 8 Felt ring | |

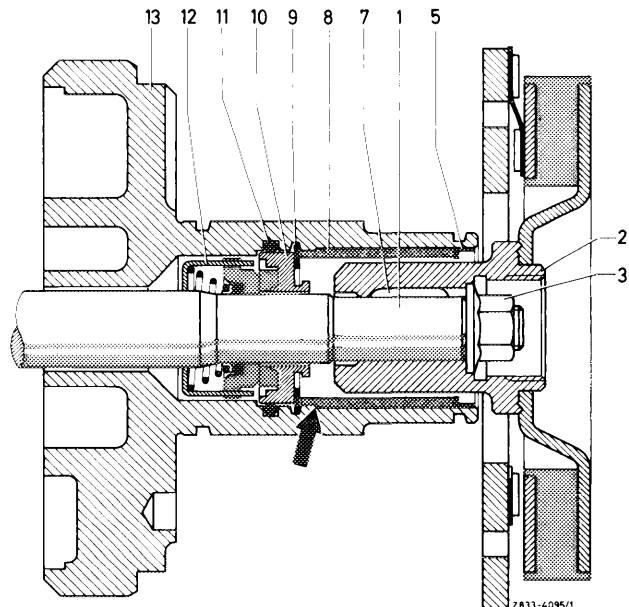

2833-4095/1







C. Delco-refrigerant compressor (engine 617.951)

Data, test values

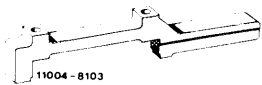
Designation	Engine 617.950
Electromagnetic shutoff clutch 12 V	Delco 4.9 inches
Power input in amps. at 13.5 V	cold 3.9 warm 3.4

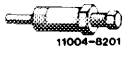
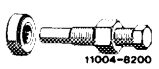
Tightening torques	Nm	(kpm)
Screws (8) pulley-clutch body	11	(1.1)
Screw M 10 x 30 pipe line to refrigerant compressor	50±3	(5±3)
Nut (1) on drive shaft	13	(1.3)
Screws (5 and 6) M 12 refrigerant compressor to carrier	60+10	(6+1)
Hose line (14) from evaporator to pipe line 7/8"	29–37	(2.9–3.7)
Hose line (15) from pipe line to condenser 3/4"	24–28	(2.4–2.8)

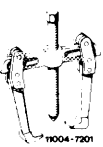
Special tools

Holding device for refrigerant compressor		116 589 14 31 00
Holding wrench for clutch		116 589 04 40 00
Remover for clutch plate		000 589 07 35 00
Installer with spacer for spring plate		000 589 49 43 00
Guide member		116 589 05 63 00
Two-claw puller		000 589 88 33 00
Knock-out mandrel		115 589 02 35 02
Pressure test plate for refrigerant compressor		109 589 00 25 00

Conventional tools

Socket 14 mm, 3/8" square	e.g. made by Hazet, 5630 Remscheid
Slip gauge (set)	e.g. made by Hazet, 5630 Remscheid order no. 2147
Langbeck pliers 72 A (internal lock)	e.g. made by Hazet, 5630 Remscheid order no. 1846 a-1
Pliers for locking ring J 2 (external lock)	e.g. made by Hazet, 5630 Remscheid order no. 1846 c-2

Self-made tool

Remover for O-ring

Note

The spring plate, the clutch body with pulley and the magnetic coil, as well as the shaft seal can only be removed and installed with refrigerant compressor removed.
The clutch body with bearing, the pulley and the magnetic coil are one complete assembly group. If a part of this assembly group must be replaced, remove complete assembly group (refer to 83–526, section b).

a) Removing and installing spring plate

Removal

- 1 Drain air-conditioning system (83–516).
- 2 Remove refrigerant compressor (83–522).
- 3 Fasten holding device to refrigerant compressor and clamp into vice. Then close openings with pressure test plate.
- 4 Loosen refrigerant compressor from holding device and reattach again with drive shaft in upward direction.

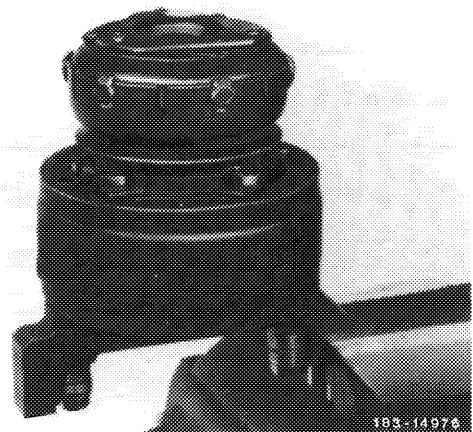
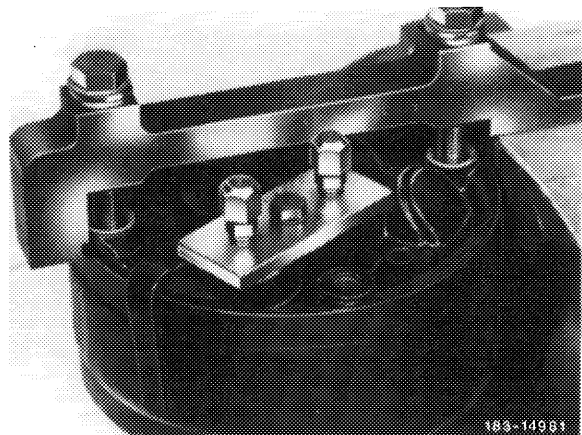

5 Prevent turning of spring plate (2) by means of a holding wrench, unscrew nut from shaft, using 14 mm wrench.

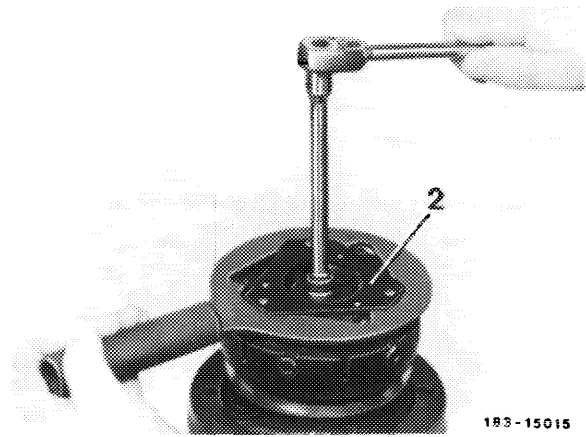

6 Screw remover into hub, hold tool in place with wrench and tighten central screw.

7 Remove key from shaft.

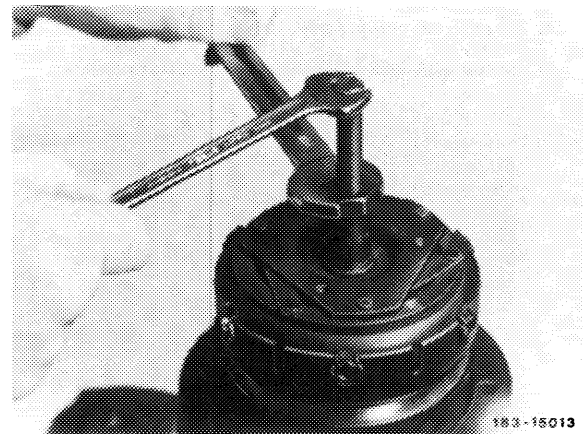

Installation

8 Clean friction surface of spring plate and clutch body.

9 Insert key (4) into groove of hub to project approx. 5 mm.

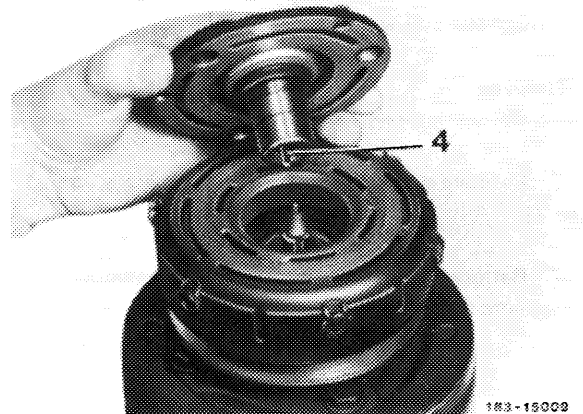

10 Place spring plate on shaft in such a manner that key and keyway are in alignment.

11 Place spacer on spring plate. Insert installation tool through spacer and screw installation tool on shaft end.

12 Hold hexagon head of tool and screw-in center screw until a clearance of approx. 0.5–1 mm is provided between friction surfaces of spring plate and clutch body.

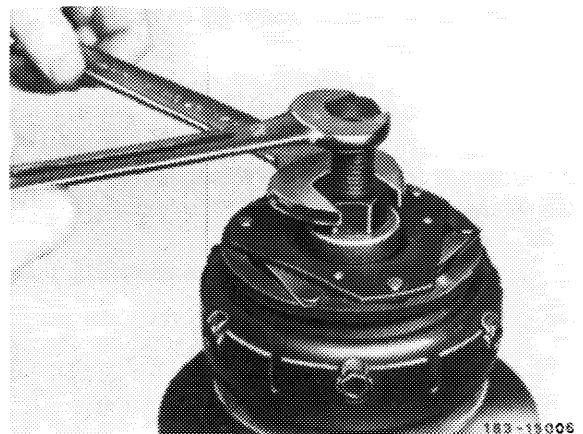

13 Remove installation tool from spacer.

14 Screw-on new nut on shaft (smaller diameter of nut in direction of shaft lug) and tighten. Check clearance once again.

15 Install refrigerant compressor (83-522).

- | | |
|---------------------------|------------------|
| 1 Nut on drive shaft | 9 Magnetic coil |
| 2 Spring plate | 10 Locking ring |
| 3 Clutch body | 11 O-ring |
| 5 Locking ring | 12 Slip ring |
| 6 Bearing for clutch body | 13 Shaft seal |
| 7 Pulley | 14 Drive shaft |
| 8 Screw with lock | 20 Housing cover |

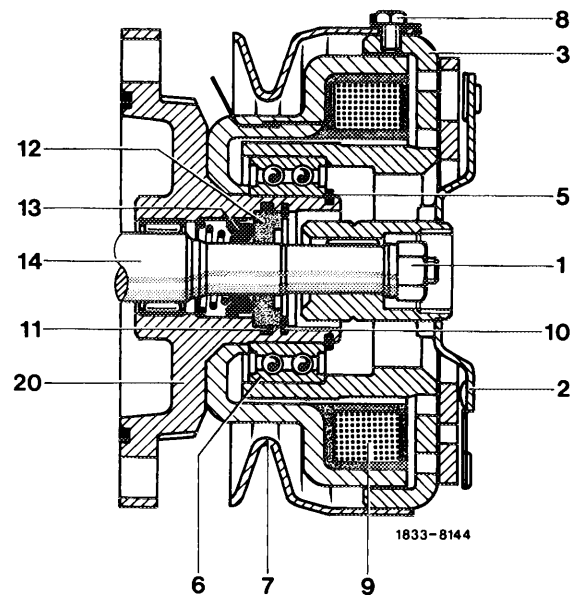

b) Removing and installing clutch body with pulley, magnetic coil and bearing.

Removal

16 Remove spring plate (83-526, section a, item 1 to 7).

17 Remove lock (5). Mark location of terminals for magnetic coil.

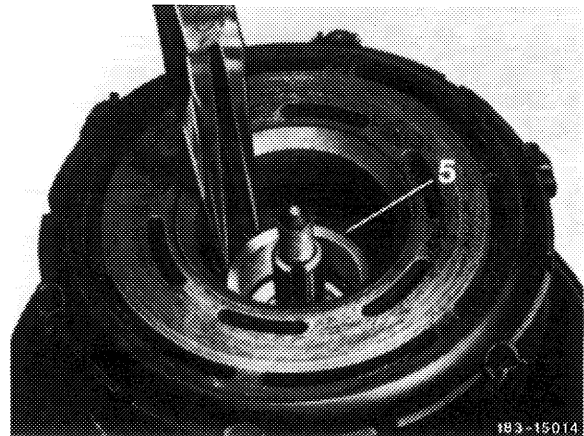

18 Insert guide member over shaft on head piece of refrigerant compressor.

19 Pull off assembly group by means of puller.

20 Unbend locks at hex. screws and remove the 6 screws together with locks.

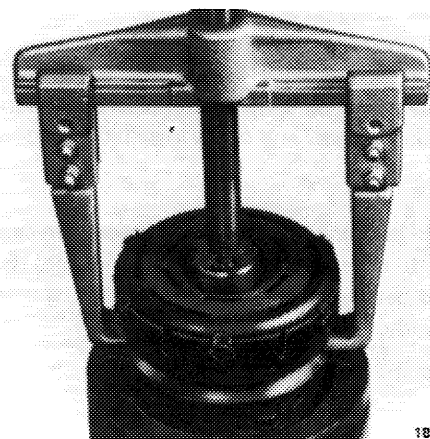

21 Remove pulley from clutch body and magnetic coil from pulley.

Note: If bearing (6) of clutch body (3) must be renewed, perform items 22 to 24.

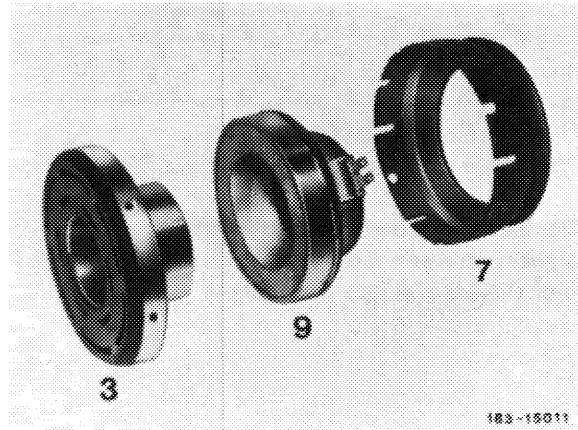

Removal of bearing

22 Place clutch body (3) on wooden support and press-out bearing (6). Removal of bearing does not require removal of notches.

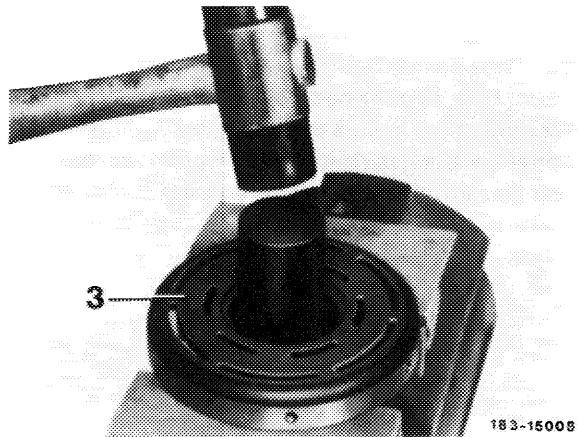

Installation of bearing

23 Align new bearing (6) accurately to bore of hub and then press-in.

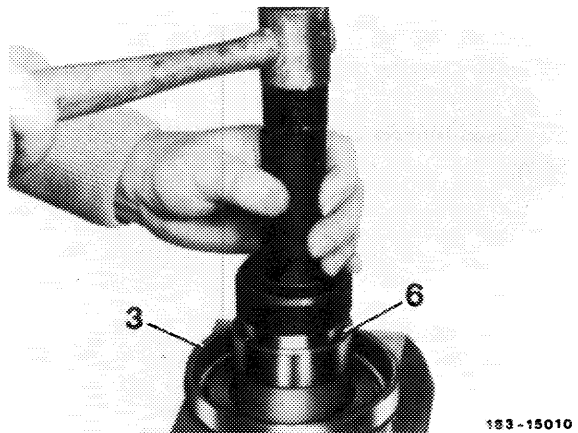

24 Punch mark bearing at 3 points 120° away from each other. Do not punch too deeply, since otherwise the outer race of bearing may become distorted. Do not use old notches again!

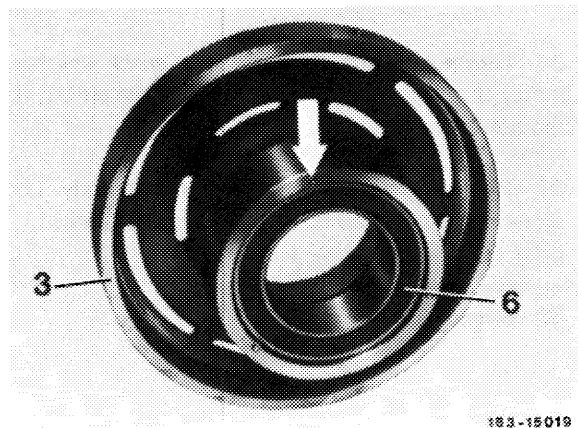

Installation

25 Insert magnetic coil (9) in pulley (7).

26 Slip clutch body (3) into pulley (7) and provisionally screw-on with new locks and screws. Provide threads of screws with Loctite.

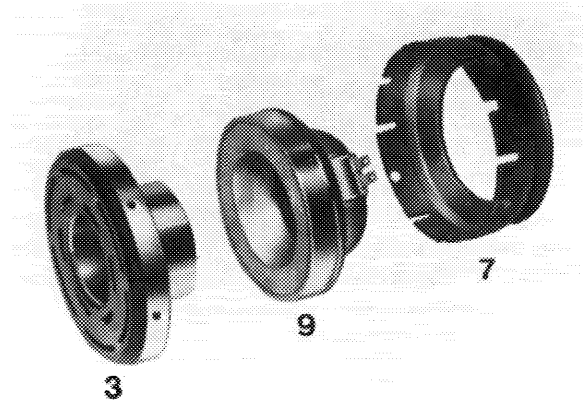

183-15011

27 Place complete assembly group on front housing cover. Prior to pressing-on assembly group, make sure that the terminals of the magnetic coil are in correct position in relation to refrigerant compressor and that the three projections on back of magnetic coil are in alignment with the three cavities in housing cover.



183-15021

28 Insert locking ring (5) for assembly group.

29 Clean friction surface of spring plate and clutch body.

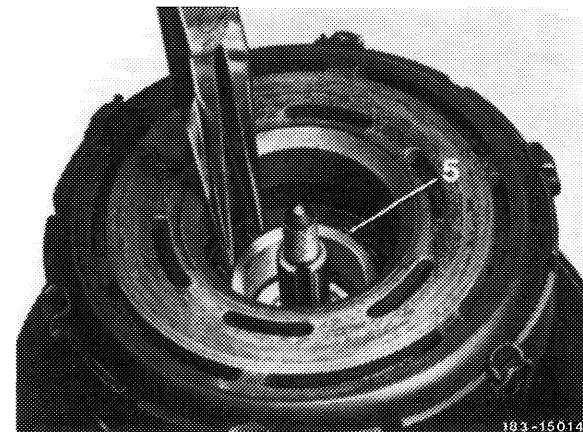

183-15014

30 Turn pulley with clutch body to check whether pulley is in alignment and slightly readjust pulley, if required.

31 Tighten screws (8) of pulley — clutch body. Lock screw heads the same way the screws were locked prior to removal.

32 Install refrigerant compressor (83-522).

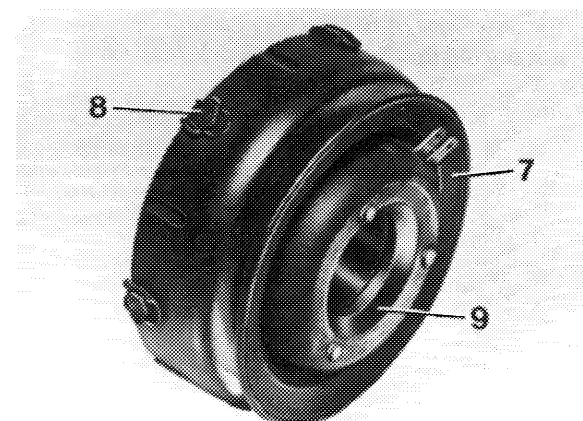

183-15012