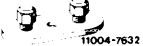

## 83-522 Removal and installation of refrigerant compressor

### B. Engines 116, 117

Oil capacity		in cc
Oil type	Refrigerant oil (for approved refrigerant oils refer to specifications for service products, page no. 362)	
Oil quantity with new refrigerant compressor		300
Oil quantity with removed refrigerant compressor and air-conditioning system flushed with R 11		300
Oil quantity with removed refrigerant compressor and air-conditioning system not flushed		200
Tightening torques		Nm
Pipe line to refrigerant compressor		17
Oil check screw		15-17
8 mm screw		35
10 mm screws		30-45
12 mm screws		40-45
Special tool		
Pressure test plate		109 589 00 25 00
Conventional tool		
Double open end wrench 3/8" x 7/16" for oil check screw		

### Note

From January up to approx. March 1980, Delco-A6-refrigerant compressors (former designation Frigidaire) were changed from inch-threads to metric threads. For identification, these refrigerant compressors are carrying a label with the note: "NOTICE, MOUNTING HOLES HAVE METRIC THREADS" (refer to Fig., arrow). Background as well as edge and separating line of this label are blue.



1834-9341

If a refrigerant compressor with inch threads is exchanged for a compressor with metric threads, use screws M 10 x 1.5 x 40 (instead of formerly 3/8") for rear fastening, and screws M 8 x 1.25 x 15 (instead of formerly 5/16") for front fastening.

The threads for fastening closing plate has been changed to M 10 x 1.5.

After using up the Delco-A6 refrigerant compressors with inch threads only compressors with metric threads will be supplied.

The refrigerant compressor can be removed and installed together with refrigerant compressor carrier only. If the compressor is removed because of a leak on compressor or on system, correct oil level in compressor by refilling with refrigerant oil, but fill-in only up to max. 200 cc refrigerant oil.

If the refrigerant compressor is replaced, drain all the refrigerant oil from new refrigerant compressor. Then fill-in refrigerant oil, but not more than max. 200 cc.

**Attention!**

If the refrigerant compressor is replaced, e.g. as a result of blocking, always renew pipe line with hoses on refrigerant compressor on principle, since there is always the possibility that small parts (abrasives) of refrigerant compressor may enter the pipe line.

Also renew fluid reservoir.

In addition, check function and direction of rotation of auxiliary fan by means of 52 °C and 100 °C switch.

When loosening or tightening hose or pipe connections, be sure to apply counterhold with a second open end wrench.

## Removal

- 1 Cover front fender.
- 2 Drain air-conditioning system (83-516).
- 3 Remove V-belt for power steering pump (13-340).
- 4 Loosen screw (15), remove belt tensioning roller (14) on refrigerant compressor carrier (2) and take-off V-belt (13).

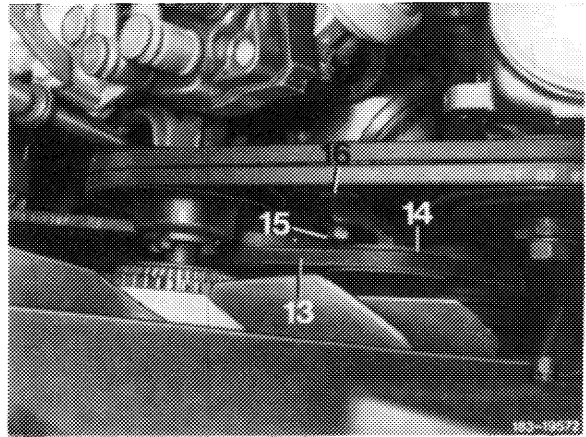

- 5 Unscrew screw (4 and 19) and remove pipe line (3) from refrigerant compressor, while paying attention to sealing rings.
- 6 Screw pressure testing plate to refrigerant compressor by means of available screw (4).

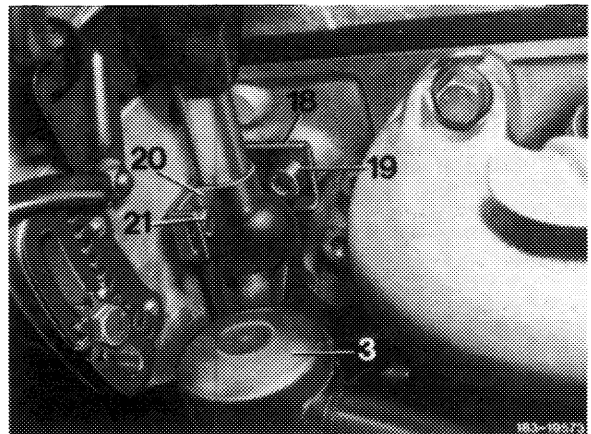
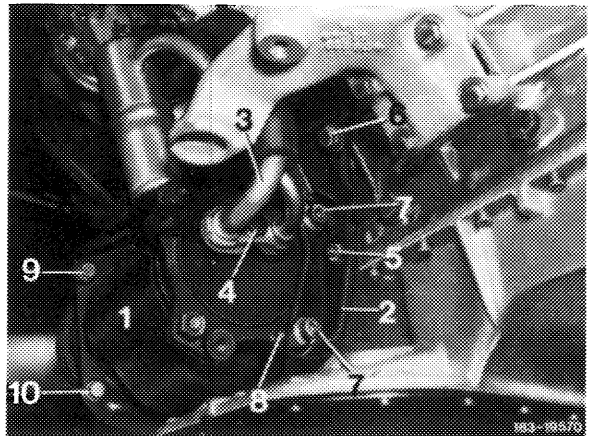

- 7 Unscrew screws (10 and 11) from supporting plate (12) on oil pan top and from refrigerant compressor.

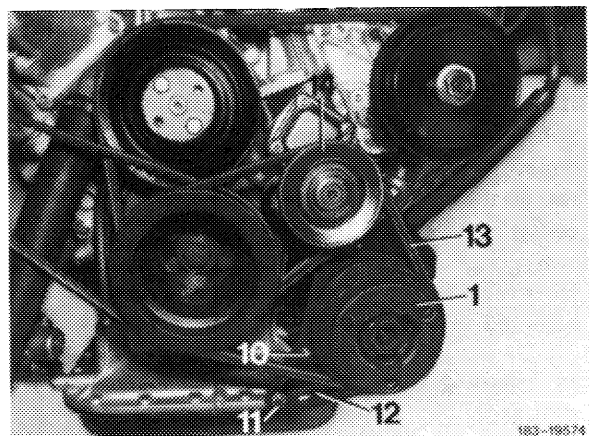

8 Unscrew screws (17) at engine face end.

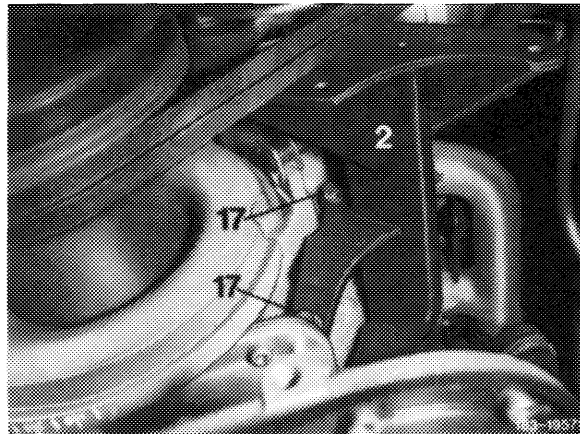

9 Unscrew screw (6) and nut (5) on refrigerant compressor carrier (2).

10 Pull electric plug connection from compressor.

11 Remove refrigerant compressor in forward direction together with carrier.

12 Unscrew refrigerant compressor from carrier and remove, while unscrewing screws (7 and 10) and removing spacing rings (8) for this purpose.

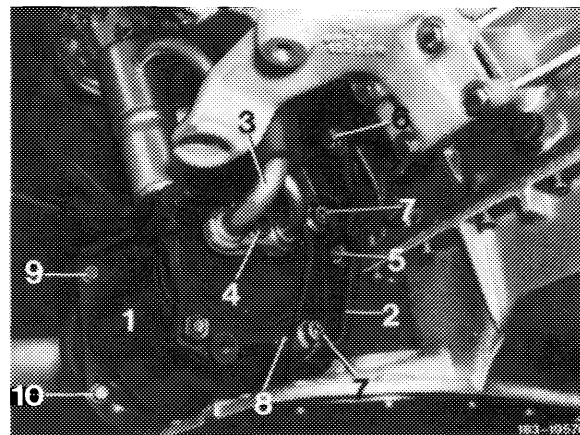

### Installation

13 Correct oil level in refrigerant compressor (83-520).

14 Reinstall pipe line (3), if removed (83-523).

15 For installation of refrigerant compressor, proceed vice versa.

### Attention!

Remove pressure testing plate for connecting pipe line, provide O-rings on refrigerant compressor with refrigerant oil and renew, if required.

Check alignment of pulley-compressor in relation to pulley-crankshaft and tensioning roller and, if required, correct alignment between tensioning roller and refrigerant compressor carrier by means of compensating washers (16).

16 Evacuate air-conditioning system and fill-up again (83-512 and 514).

17 Check air-conditioning system for function (83-510).

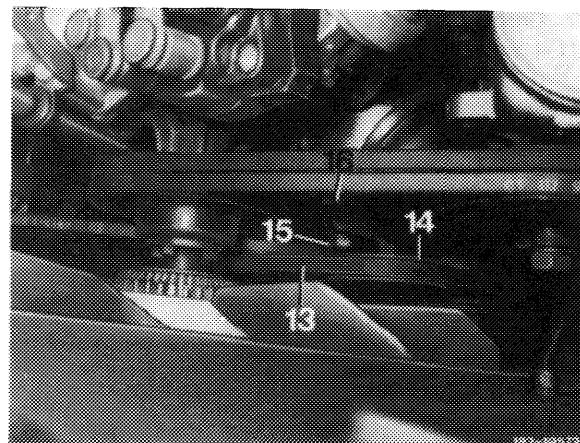

## C. Engine 617.951

### Oil capacity

Oil type refrigerant oil (for approved refrigerant oils refer to specifications for service products, page no. 362)

Oil quantity, new in refrigerant compressor 170 cc

Tightening torques	Nm	(kpm)
Screws M 12 refrigerant compressor to carrier	60+10	(6+1)
Screw pipe line to refrigerant compressor	50±3	(5±0.3)
Hose line from evaporator to pipe line 7/8"	29–37	(2.9–3.7)
Hose line from pipe line to condenser 3/4"	24–28	(2.4–2.8)

### Special tools

Holding device for refrigerant compressor  116 589 14 31 00

Pressure test plate for refrigerant compressor  109 589 00 25 00

### Conventional tools

Double open end wrench 1/2" x 9/16", 5/8" x 3/4", 7/8" x 15/16", 1" x 11/8"  
Socket 14 mm, 3/8" square

Assembly tester with 3 filling hoses or evacuating and filling device for air-conditioning system e.g. made by Christof Fischer, Augsburg Str. 289, 7000 Stuttgart 60

### Attention!

If the refrigerant compressor is replaced, e.g. as a result of blocking, always renew pipe line with hoses on refrigerant compressor on principle, since there is always the possibility that small parts (abrasives) of refrigerant compressor may enter the pipe line.

Also renew fluid reservoir.

In addition, check function and direction of rotation of auxiliary fan by means of 52 °C and 100 °C switch.

## Removal

---

- 1 Cover front fender.
- 2 Pull plug from electromagnetic coupling and drain air-conditioning system (83-516).

3 Loosen screw (5 and 6).

4 Loosen nut (3) on tensioning screw (4). Swivel refrigerant compressor (1) inwards and remove V-belt (2).

- |                          |                    |
|--------------------------|--------------------|
| 1 Refrigerant compressor | 6 Screw M 12 x 140 |
| 3 Nut                    | 7 Pipe line        |
| 4 Tensioning screw       | 8 Screw M 10 x 30  |
| 5 Screw M 12 x 170       |                    |

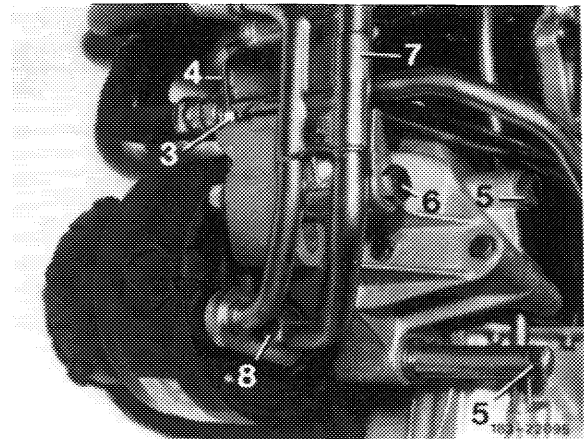

- |                          |
|--------------------------|
| 1 Refrigerant compressor |
| 2 V-belt                 |

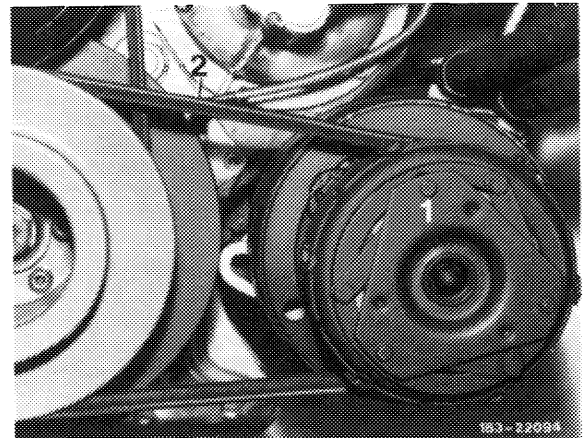

5 Unscrew pipe line (7) and close connections with plug.

6 Screw out screw (5 and 6) and remove refrigerant compressor (1).

7 If the refrigerant compressor is renewed or reconditioned, refer to section "Checking oil level in refrigerant compressor" (83-520).

7 Pipe line

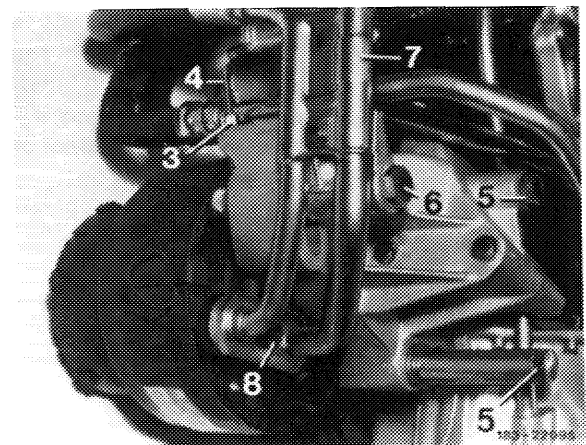

## Installation

8 Check O-rings on refrigerant compressor.

9 Provisionally screw refrigerant compressor to carrier by means of screws (5 and 6), tensioning screw (4), spacing sleeve (9) and spacing washers (10, 11 and 12).

- |                          |                         |
|--------------------------|-------------------------|
| 1 Refrigerant compressor | 9 Spacing sleeve        |
| 3 Nut                    | 10 Spacing washer 5 mm  |
| 4 Tensioning screw       | 11 Spacing washer 13 mm |
| 5 Screw M 12 x 170       | 12 Spacing washer 9 mm  |
| 6 Screw M 12 x 140       | 13 Spring washer        |

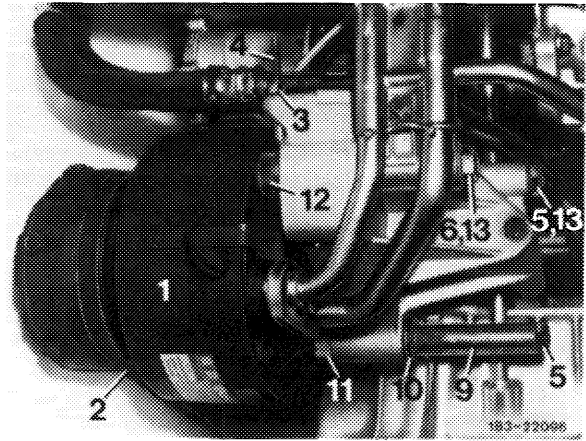

10 Screw nut (3) to tensioning screw (4).

11 Mount V-belt (2) and tension with nut (3).

- |                          |                        |
|--------------------------|------------------------|
| 1 Refrigerant compressor | 4 Tensioning screw     |
| 2 V-belt                 | 12 Spacing washer 9 mm |
| 3 Nut                    |                        |

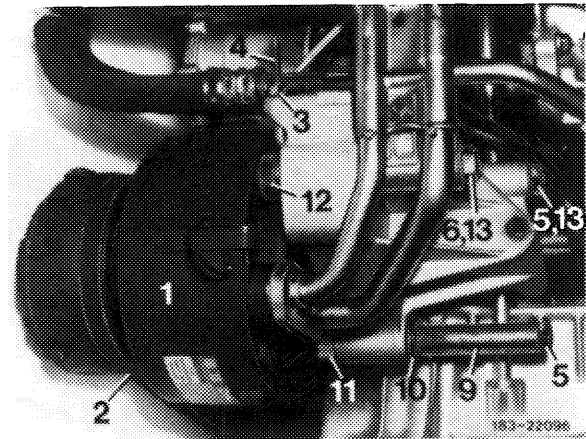

12 Tighten screws (5 and 6).

13 Remove closing caps on pipe line. Provide O-rings with refrigerant oil, screw-on pipe line and tighten.

14 Mount plug on electromagnetic coupling.

15 Evacuate system and fill up again (83-512, 514).

### Attention!

If oil is filled into refrigerant compressor, handle compressor like a new refrigerant compressor, that is, during initial operation engine should run at idle for 4 minutes only.

16 Check air conditioning for function and leaks (83-510, 512).

