

43-0628 R and R vacuum pump piston seal and plate valves

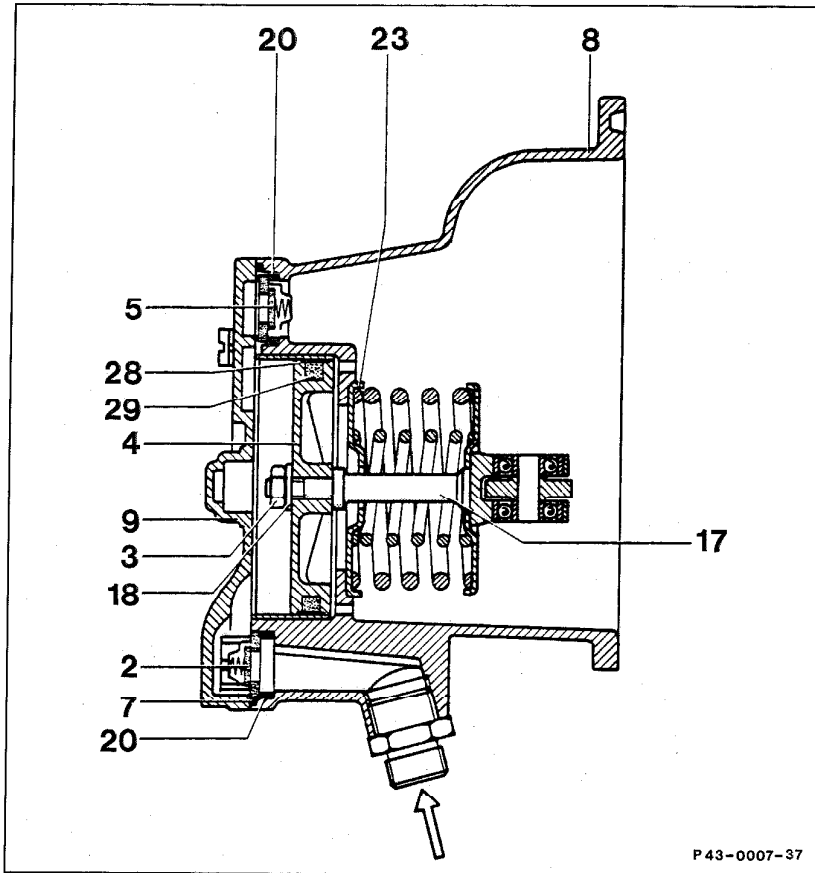

P 43-0007-37

P43-0007-37

- | | |
|--|--|
| Vacuum pump | install in assembly plate 115 589 14 21 00. |
| Pump cover (9) | screw off, screw on, tightening torque for
slotted screws 2.5 Nm. |
| Gasket (7), plate valves (2 and 5) | remove from pump housing (8), install. |
| Piston (4) | remove, install. Replace self-locking hex.
nuts (3), 9 Nm. |
| Piston (4) | disassemble, assemble (observe items
9 and 10). |

Special tool

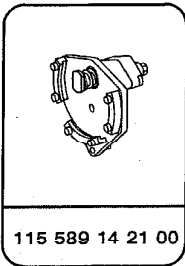

Note

Repair kit part no. 000 586 17 23 is required for reconditioning the vacuum pump.

Disassembly

- 1 Turn assembly plate spindle all the way back.
- 2 Insert vacuum pump into assembly plate (050) so that the cast seam points exactly to the center between the two Allen bolts (25) in the plate.
- 3 Screw spindle in against stop to press piston rod together with piston to top dead center.
- 4 Screw slotted screws out of pump housing and remove pump cover (9).
- 5 Remove gasket (7) for pump cover as well as gaskets and plate valves (2 and 5) from pump housing.

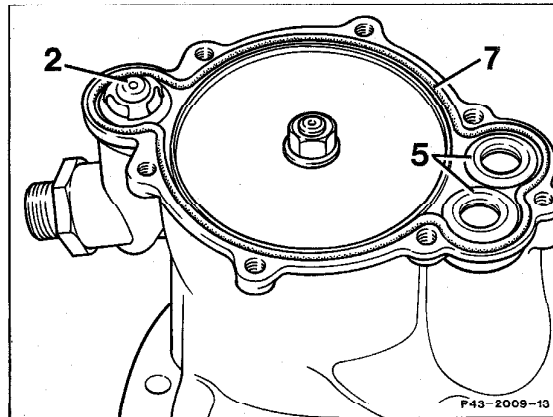
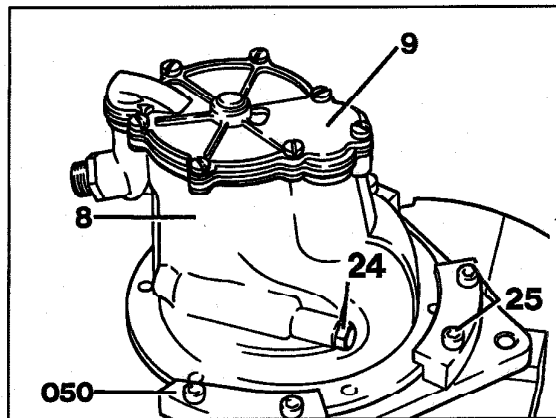

43-0628 R and R vacuum pump piston seal and plate valves

6 Screw self-locking hex. nut (3) off of piston rod (17) and remove washer (18).

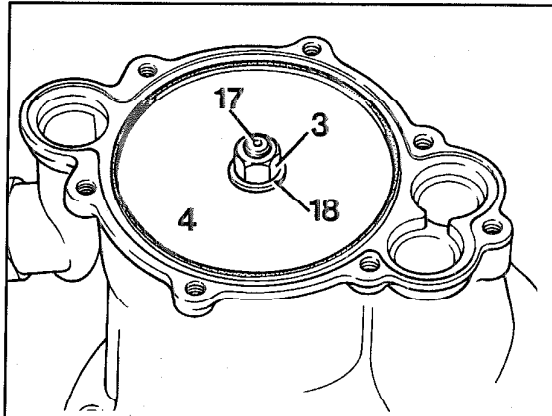

P43-2008-13

7 Screw assembly plate spindle all the way back. Then pull piston (4) out of pump housing (8) with suitable pliers.

8 Remove piston plate from pump housing (8).

Note

Starting 02/83 the piston plate was eliminated with a simultaneous modification to the piston.

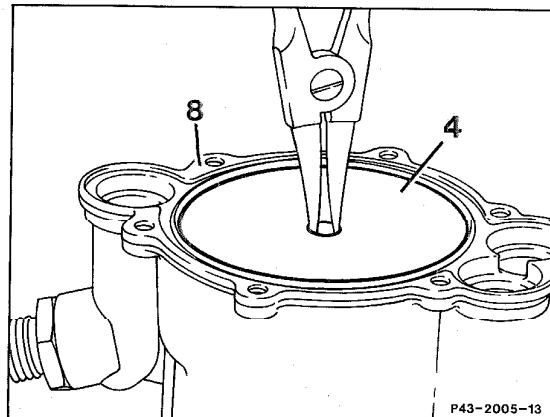

P43-2005-13

P43-2005-13

9 Remove piston ring (28) and O-ring (29) from piston (4).

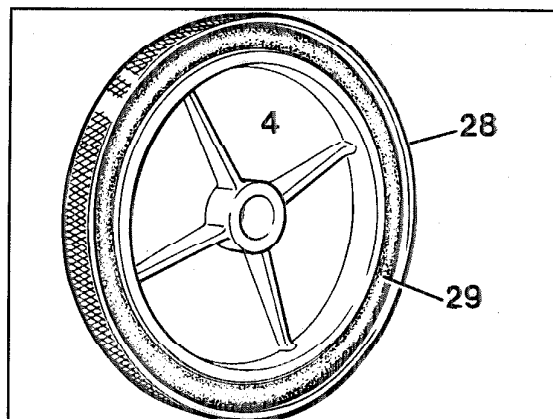

P43-2007-13

Piston up to 01/83

43-0628 R and R vacuum pump piston seal and plate valves

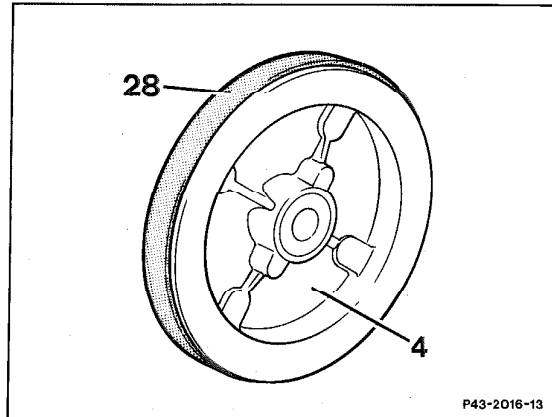

Piston starting 02/83

P43-2016-13

P43-2016-13

Assembly

Note

Before assembly check piston sleeve and roller for wear. If sleeve is worn excessively or scored, replace vacuum pump. If roller, ball bearing, piston rod, pivot lever or pivot lever shaft show signs of wear, recondition vacuum pump with repair kit part no. 000 586 18 23 (42-0635).

Check sealing surfaces on pump cover for gasket. The cover must be flat and level.

10 Clean piston (4). Install new O-ring (29) and piston ring (28). Oil parts lightly.

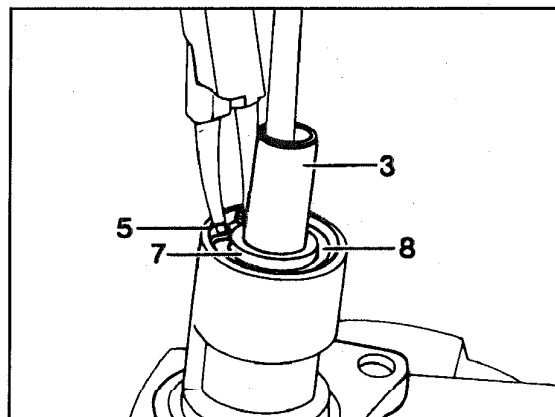

Piston up to 02/83

P42-2013-13

43-0628 R and R vacuum pump piston seal and plate valves

Piston starting 02/83

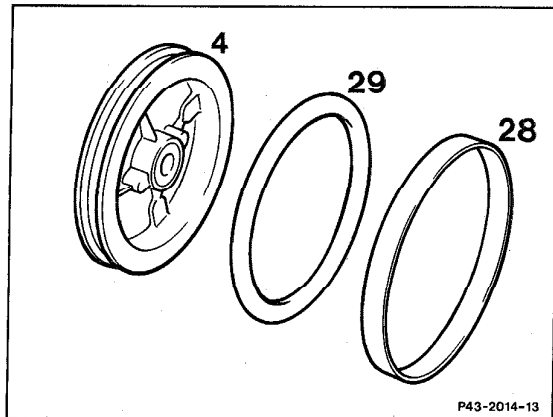

P43-2014-13

11 Press piston rod (17) up against stop with assembly plate spindle. Assure that the collar on the piston rod is guided properly through the upper spring plate (023).

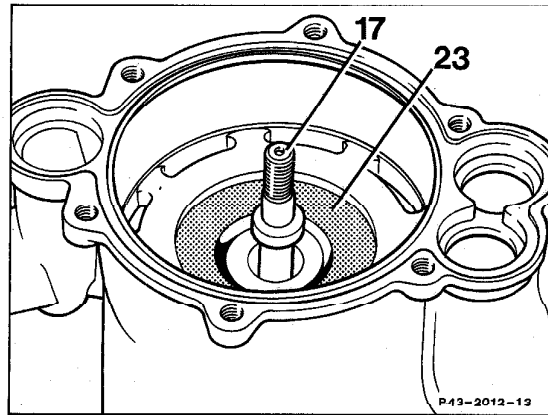

P43-2012-13

12 On 1st version up to 01/83 position piston plate (10) on piston rod (17) with the 4 center points in front.

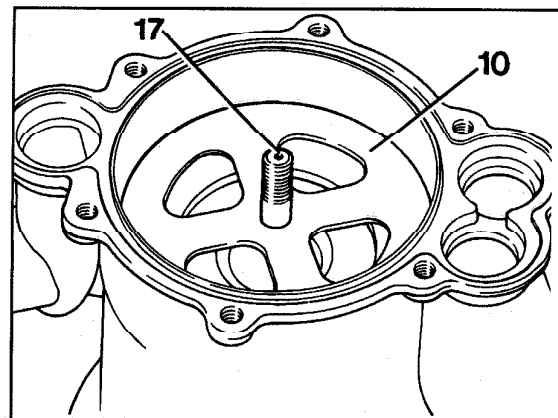

P43-2010-13

13 Oil piston sleeve slightly.

43-0628 R and R vacuum pump piston seal and plate valves

14 Install piston (4) assuring that the piston ring is not damaged.

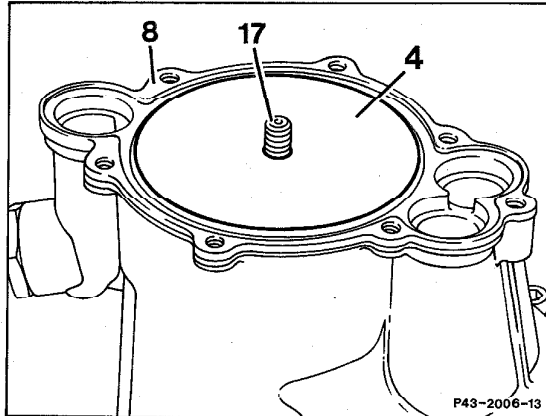

P43-2006-13

15 Position washer (18). Then screw on new self-locking hex. nuts (3) loosely and move piston (4) to stop on base of housing by turning back spindle. Then tighten hex. nut (3) to 9 Nm.

Note

The self-locking hex. nut can only be used once.

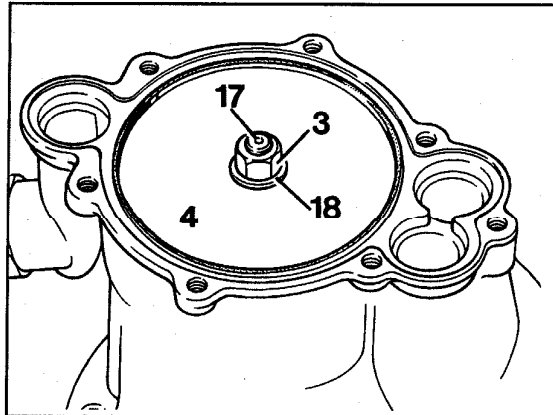

P43-2008-13

43-0628 R and R vacuum pump piston seal and plate valves

16 Insert sealing ring (1) new sealing rings and the three plate valves (2 and 5) into the pump housing in the correct position for installation.

Arrangement, intake side

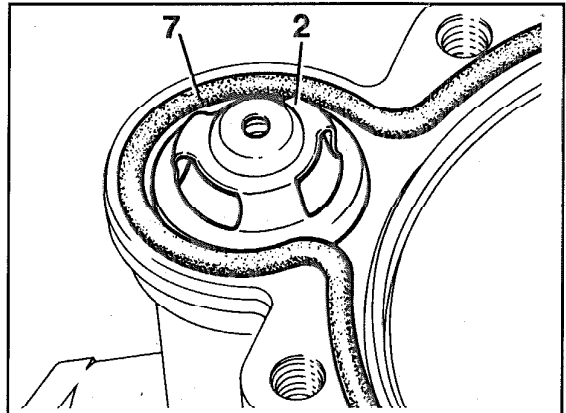

P43-2004-13

Arrangement, outlet side

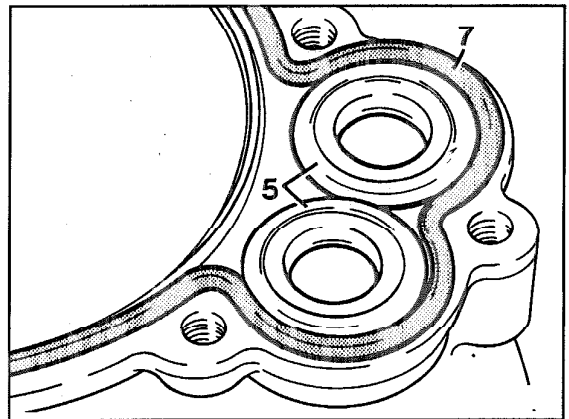

P43-2003-13

17 Position pump cover (9) on housing. Screw in slotted screws and tighten to 2.5 Nm.

18 Remove pump from assembly plate.

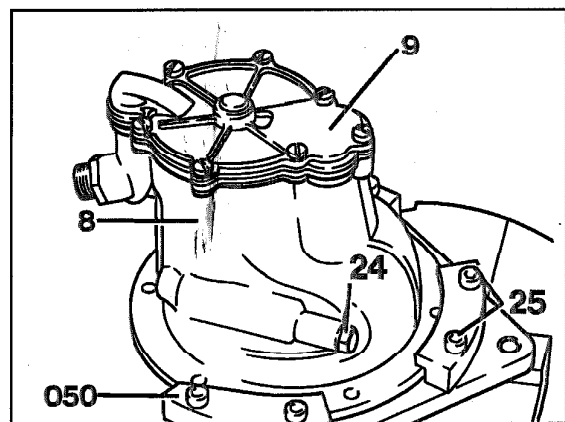

P43-2011-13