

P43-0004-57

P43-0004-57

- | | |
|-------------------------------------|---|
| Vacuum line (8) | screw off at booster unit (1), screw on, 30 Nm. |
| Test fitting (070) | install between booster unit and line.
(Self-made test fitting). |
| Tester (030) 201 589 13 21 00 | attach to test fitting. |
| Connection fitting | connect to bleed fitting on one brake caliper
after screwing out bleed screw. |
| Pressure tester (051) | connect to connection fitting and bleed.
After testing bleed only brake caliper (42-010),
to which the pressure tester was connected. |
| Pedal force gauge (060) | attach to brake pedal. |

43-0325 Testing brake booster

Test booster unit allow engine to run and bring vacuum to 0.75–0.8 bar by depressing accelerator and releasing suddenly.

Note

If the vacuum achieved is significantly lower or if the vacuum decreases again immediately, the O-ring between the booster unit and tandem master brake cylinder may be damaged or the check valve in the vacuum line may be defective. Test vacuum pump on vehicles with diesel engine (07.1–0160).

Brake pedal actuate with prescribed force, read off line pressure (see table).

Note

A tolerance to the nominal value of ± 10 bar is permissible to cover measuring errors (incorrect force on brake pedal, wrong vacuum) and inaccuracies in the testing equipment. Replace booster unit according to condition (43-0350). Test check valve for leakage (43-0003).

Data

Force on brake pedal	Vacuum in bar Teves T 52/225/9" Double ¹⁾	Line vacuum in bar Teves T 52/4 A 225-210, Girling LSC 115 T 8"/9" double ²⁾
50	0.75–0.8	2–12
100		28–40
150		54–68
200		80–97
250		105–125
300		132–140
Overlap between push rod piston in master brake cylinder and booster unit push rod		

¹⁾ Installed up to August 1985.

²⁾ Installed starting September 1985.

Special tool

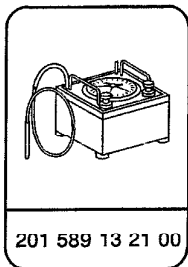

Commercially available tools

Pressure tester (051)

e.g. Teves
D-6000 Frankfurt/M.
Order no. 3 9305-1020.4

Pedal force gauge (060)

e.g. Bosch Prüftechnik
D-7000 Stuttgart
Order no.
0 681 148 015 EFSV 57 B

Self-made tool

Make test fitting according to drawing (parts 1, 3, 4, 5 and 6 are brazed to one another).

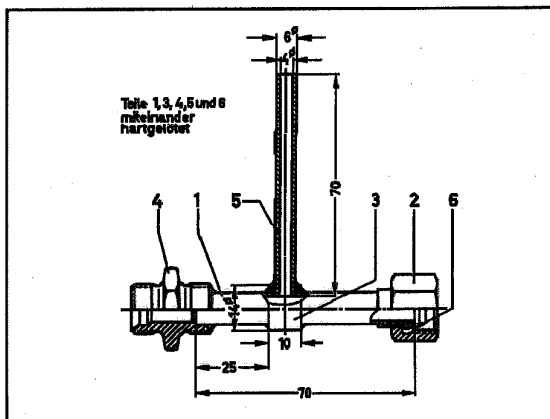

P100-0032-13