

**Note:**

Diagnosis of this system requires special equipment to ensure safe and accurate diagnosis.

**A. With adapter**

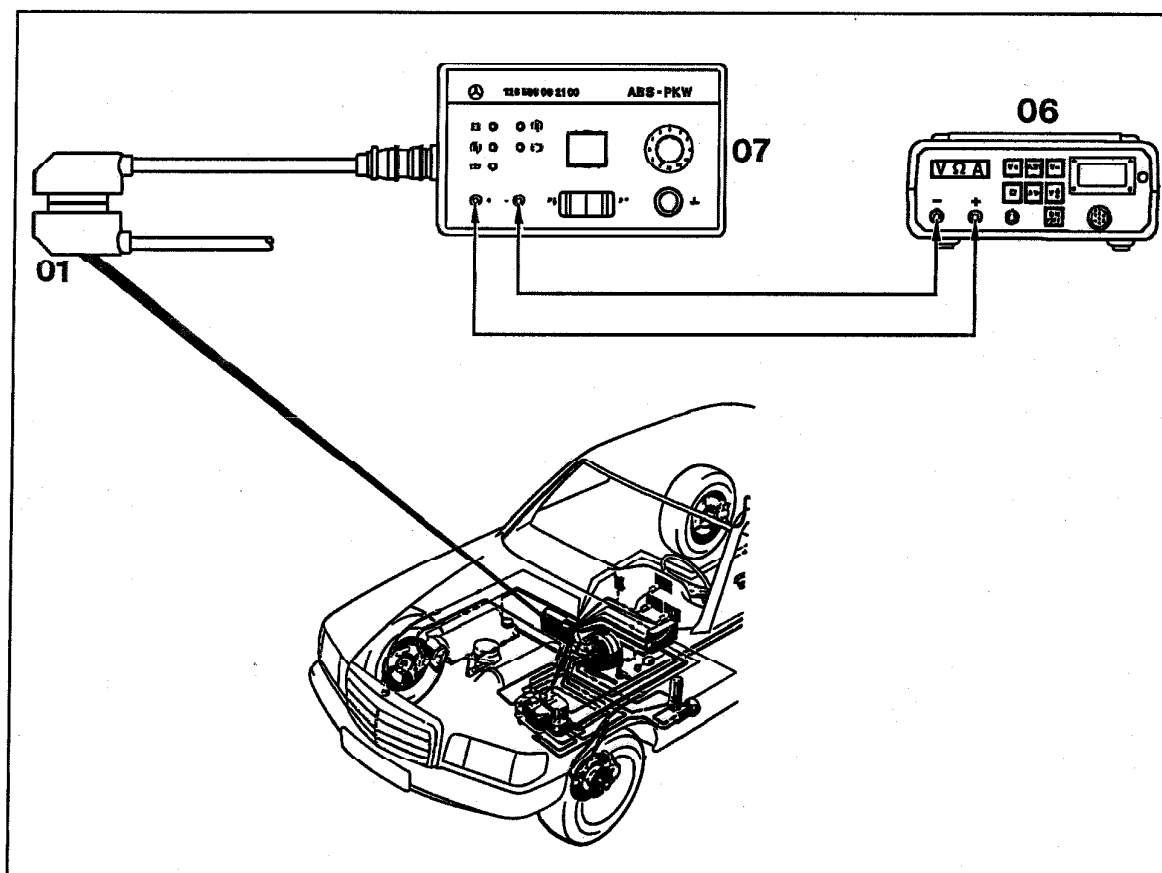

P42-0078-57

- 01 Connector - ABS control module (N30)
- 06 Multimeter
- 07 ABS adapter

**Special tools**

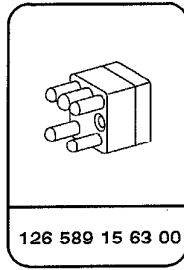
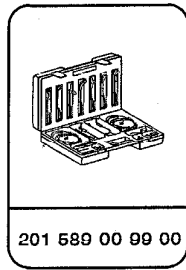
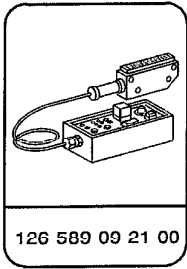

**Commercially available tool**

---

Multimeter

e. g. Sun, DMM-5

---

## 42-720 Electrical testing

### Complaint-related troubleshooting schedule

Complaint	Possible cause	Remedy Description of diagnosis Test step/adapter position
Pulsating pedal under light braking, shortly before vehicle stops	Wheel speed sensor voltage too low	8/4-13/6, 17/4, 20/5, 23/6
ABS indicator lamp comes on while driving and does not go out again	Wheel speed sensor cable interrupt	8/4-13/6, 17/4, 20/5, 23/6
ABS indicator lamp comes on while driving and goes out again	System voltage < 11 V, too many electrical ancillaries in use	3/1
ABS indicator lamp comes on, charge indicator lamp goes out	Defective alternator (1 diode)	Check alternator
ABS indicator lamp and charge indicator lamp come on	Defective alternator (2 diodes)	Check alternator
ABS indicator lamp does not go out when engine starts	ABS control module connector (N30) not connected. Plug connection has bad contact. Overvoltage protection relay defective.	1/1, 3/1
ABS indicator lamp comes on when ignition is switched on	Diode in solenoid valve relay defective	7/3
Return pump runs when ignition key is removed	Return pump relay (A7k2) sticks	Replace relay (A7k2)

### Notes on adapter

Using this tester the complete ABS system can be checked with the exception of the electronic control module.

### Conditions for test

On all test steps with ignition: **ON** the LED  must come on, which means battery voltage is correct, and the remaining electrical ancillaries must be switched off.

### **WARNING!**

The vehicle must not be driven with the ABS adapter (07) connected.

### Connection diagram

With the ignition switched off, detach connector from ABS control module (N30) and connect to the adapter. Connect multimeter (06) to ABS adapter (07).

## 42-720 Electrical testing

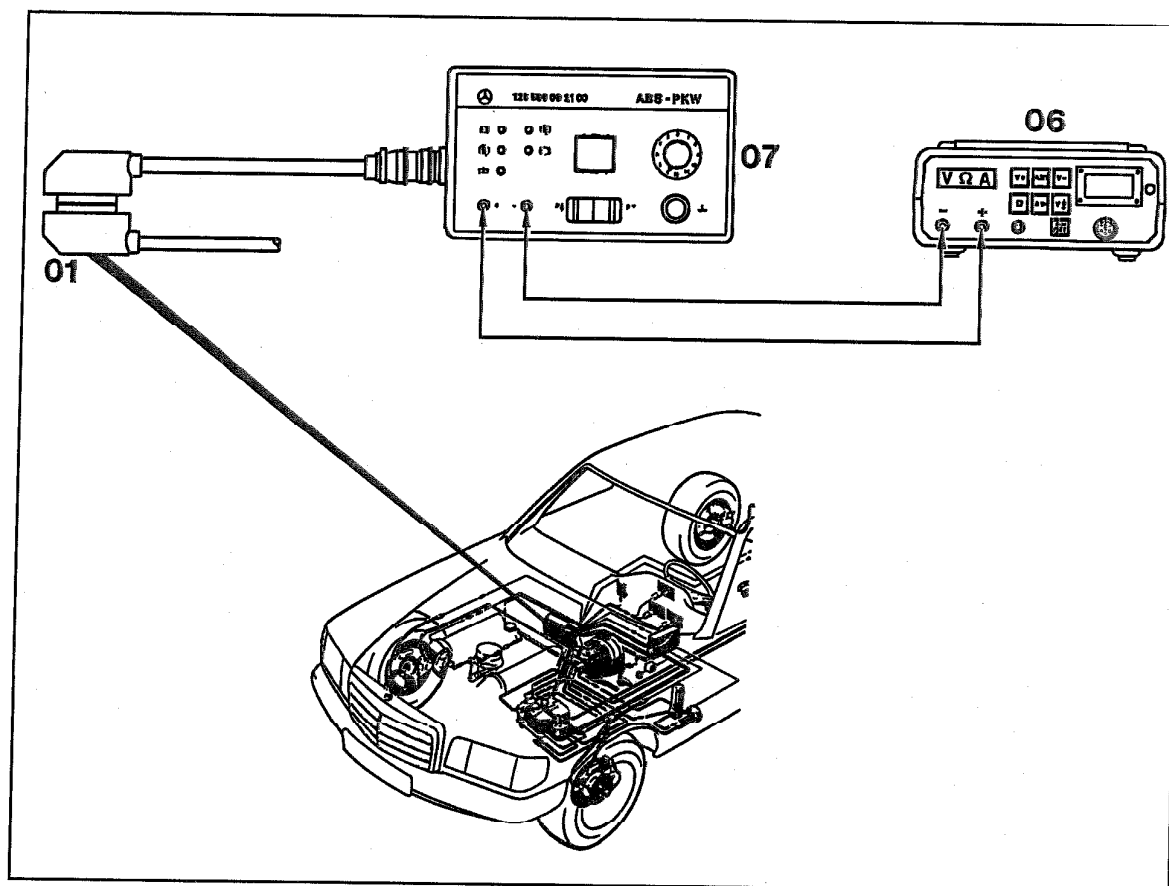







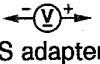

P42-0078-57









- 01 Connector - ABS control module (N30)
- 06 Multimeter
- 07 ABS adapter











Up to 09/85 the overvoltage protection relay can be checked by plugging the relay into the test adapter. The protection adapter part no. 126 589 15 63 00 is to be used with the overvoltage protection relay from 09/85 with 5 plugs. The test is performed in accordance with operation no. 42-725 on vehicles with 5-, 7- or 9-pin overvoltage protection as of 09/87.

## Test program



















Test step/ adapter position	Test scope	Test connection	Test condition	Nominal value	Possible cause/remedy
1/1	Overvoltage protection relay (K1/1)	-	Ignition: <b>OFF</b>	LED: All: <b>OFF</b>	Replace overvoltage protection relay (K1/1) (figure 3-5).
2/1	Solenoid valve relay (A7k1)	-	Ignition: <b>OFF</b>	LED: All: <b>OFF</b>	Replace solenoid valve relay (A7k1) (figure 1).
3/1	Overvoltage protection relay (K1/1)	 to ABS adapter	Ignition: <b>ON</b>	11-14 V LED:  : <b>ON</b>  : <b>ON</b>  ABS indicator lamp: <b>ON</b>	Battery state of charge incorrect. Replace overvoltage protection relay fuse. Replace overvoltage protection relay. Cable to N30 control module jack 1 interrupted. Poor contact at plug connection on overvoltage protection. Replace solenoid valve relay (A7k1). Replace ABS indicator lamp (A1e17).
4/1	Alternator terminal 61	-	Engine: allow to run briefly	LED:  : <b>OFF</b>	Connection cables interrupted, alternator defective.
5/1	Stop lamp switch (S9/1)	-	Ignition: <b>ON</b> Brake pedal: operate	LED:  : <b>ON</b>	Poor contact at plug connection. Replace stop lamp switch (S9/1).
6/2	Solenoid valve relay (A7k1)	-	Ignition: <b>ON</b>	LED:  : <b>ON</b>  : <b>ON</b>  : <b>ON</b>  ABS indicator lamp: <b>ON</b>	Connection cables interrupted. Replace solenoid valve relay (A7k1) (figure 1).











## 42-720 Electrical testing

Test step/ adapter position	Test scope	Test connection	Test condition	Nominal value	Possible cause/remedy
7/3	Diode in solenoid valve relay (A7k1) or in plug socket of hydraulic unit	 to ABS adapter	Ignition: <b>ON</b>	0.4–1.5 V E: <b>ON</b> G: <b>ON</b>	Replace solenoid valve relay (A7k1) or up to 1/86 the hydraulic unit (figure 1).
8/4	Internal resistance - left front axle speed sensor (L6/1)	 to ABS adapter	Ignition: <b>ON</b>	0.85–2.3 kΩ	Plug connections make bad contact, (figure 11) connection leads interrupted. Replace wheel speed sensor (L6/1) (figure 7).
9/4	Insulation resistance - left front axle speed sensor (L6/1)	 to ABS adapter	Ignition: <b>ON</b> Press button 	> 20 kΩ	Plug connections make bad contact (figure 11) Replace wheel speed sensor (L6/1) (figure 7).
10/5	Internal resistance - right front axle speed sensor (L6/2)	 to ABS adapter	Ignition: <b>ON</b>	0.85–2.3 kΩ	Plug connections make bad contact (figure 11). Connection leads interrupted. Replace wheel speed sensor (L6/2) (as figure 7).
11/5	Insulation resistance - right front axle speed sensor (L6/2)	 to ABS adapter	Ignition: <b>ON</b> Press button 	> 20 kΩ	Plug connections make bad contact (figure 11). Replace wheel speed sensor (L6/2).
12/6	Internal resistance - rear axle speed sensor (L6)	 to ABS adapter	Ignition: <b>ON</b>	0.6–1.6 kΩ	Plug connection makes bad contact (figure 12). Replace wheel speed sensor (L6) (figure 8).

Test step/ adapter position	Test scope	Test connection	Test condition	Nominal value	Possible cause/remedy
13/6	Insulation resistance - rear axle speed sensor (L6)	 to ABS adapter	Ignition: <b>ON</b> Press button $\perp$	> 20 k $\Omega$	Plug connection makes bad contact (figure 12). Replace wheel speed sensor (L6) (figure 8).
14/8	Internal resistance - left front axle solenoid valve (A7y1)	 to ABS adapter	Ignition: <b>OFF</b> Press button $\perp$	0.7-2.2 k $\Omega$	Plug connection to hydraulic unit (A7) makes bad contact (figure 1). Connection leads interrupted. Replace hydraulic unit (A7).
15/9	Internal resistance - right front axle solenoid valve (A7y2)	 to ABS adapter	Ignition: <b>OFF</b> Press button $\perp$	0.7-2.2 k $\Omega$	Plug connection on hydraulic unit (A7) makes bad contact (figure 1). Connection leads interrupted. Replace hydraulic unit.
16/10	Internal resistance - rear axle solenoid valve (A7y3)	 to ABS adapter	Ignition: <b>OFF</b> Press button $\perp$	0.7-2.2 k $\Omega$	Plug connection on hydraulic unit (A7) makes bad contact (figure 1). Connection leads interrupted. Replace hydraulic unit.
17/4	Check left front axle speed sensor (L6/1) voltage	 to ABS adapter	Ignition: <b>ON</b> Left front wheel: turn (approx. 1/s)	$\geq 0.1$ V~	Wheel bearing play excessive. Plug connection makes bad contact (figure 11). Connection leads interrupted or interchanged. Replace wheel speed sensor (L6/1).
18/8	Left front axle solenoid valve (A7y1) pressure holding	 remains connected	Ignition: <b>ON</b> Left front wheel: turn (approx. 1/s) Press switch: P = Operate brake pedal.	LED:  : <b>ON</b>  : <b>ON</b>  : <b>ON</b>  : <b>ON</b> Wheel must be able to turn.	Ground (14) makes bad contact (figure 9). Brake lines to hydraulic unit (A7) interchanged (figure 10). Connection leads interchanged. Replace hydraulic unit (A7).

## 42-720 Electrical testing

Test step/ adapter position	Test scope	Test connection	Test condition	Nominal value	Possible cause/remedy
19/8	Left front axle solenoid valve (A7y1) pressure reduction	 remains connected	Ignition: <b>ON</b> Operate brake pedal. Press switch: P ↓ Turn left front wheel (approx. 1/s).	LED:  : <b>ON</b>  : <b>ON</b>  : <b>ON</b>  : <b>ON</b>  : <b>ON</b> Wheel must be able to turn	Ground (14) makes bad contact (figure 9). Replace return pump relay (A7k2) (figure 1). Replace hydraulic unit (A7).
20/5	Check right front axle speed sensor (L6/2) voltage	 to ABS adapter	Ignition: <b>ON</b> Turn right front wheel (approx. 1/s).	≥ 0.1 V~	Wheel bearing play excessive. Plug connection makes bad contact. Connection leads interrupted or interchanged. Replace wheel speed sensor (L6/2).
21/9	Right front axle solenoid valve (A7y2) pressure holding	 remains connected	Ignition: <b>ON</b> Turn right front wheel (approx. 1/s). Press switch: P = Operate brake pedal.	LED:  : <b>ON</b>  : <b>ON</b>  : <b>ON</b>  : <b>ON</b> Wheel must be able to turn.	Ground (14) makes bad contact (figure 9). Brake lines to hydraulic unit interchanged. Connection leads interchanged (figure 10). Replace hydraulic unit (A7).
22/9	Right front axle solenoid valve (A7y2) pressure reduction	 remains connected	Ignition: <b>ON</b> Operate brake pedal. Press switch: P ↓ Turn right front wheel (approx. 1/s).	LED:  : <b>ON</b>  : <b>ON</b>  : <b>ON</b>  : <b>ON</b>  : <b>ON</b> Wheel must be able to turn	Ground (14) makes bad contact (figure 9). Replace return pump relay (A7k2). Replace hydraulic unit (A7).

Test step/ adapter position	Test scope	Test connection	Test condition	Nominal value	Possible cause/remedy
23/6	Check rear axle speed sensor (L6) voltage	 to ABS adapter	Ignition: <b>ON</b> Turn one rear wheel (approx. 1/s) 1)	$\geq 0.1 \text{ V} \sim$	Wheel speed sensor contaminated. Plug connection makes bad contact (figure 12). Connection leads interrupted. Replace wheel speed sensor (L6).
24/10	Rear axle solenoid valve (A7y3) pressure holding	 remains connected	Ignition: <b>ON</b> Turn one rear wheel (approx. 1/s) 1) Press switch: P = Operate brake pedal	LED:  : <b>ON</b>  : <b>ON</b>  : <b>ON</b>  : <b>ON</b> Wheel must be able to turn.	Ground (14) makes bad contact (figure 9). Brake lines to hydraulic unit interchanged. Connection leads interchanged (figure 10). Replace hydraulic unit (A7).
25/10	Rear axle solenoid valve (A7y3) pressure reduction	 remains connected	Ignition: <b>ON</b> Operate brake pedal. Press switch: P ↓ Turn one rear wheel (approx. 1/s) 1)	LED:  : <b>ON</b>  : <b>ON</b>  : <b>ON</b>  : <b>ON</b> Wheel must be able to turn.	Ground (14) makes bad contact (figure 9). Replace return pump relay (A7k2) (figure 1). Replace hydraulic unit (A7).

1) When turning one wheel make sure that the other wheel does not turn at the same time.

Figure 1

A7k1 Solenoid valve relay  
A7k2 Return pump relay

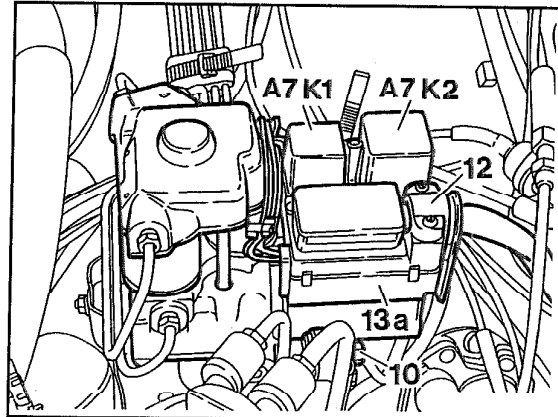

P42-2150-13

Figure 2

N30 Control module

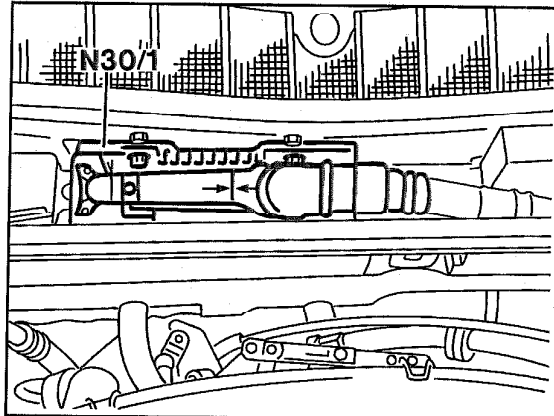

P42-2101-13A

Figure 3

51 Overtoltage protection  
1st version up to 08/81

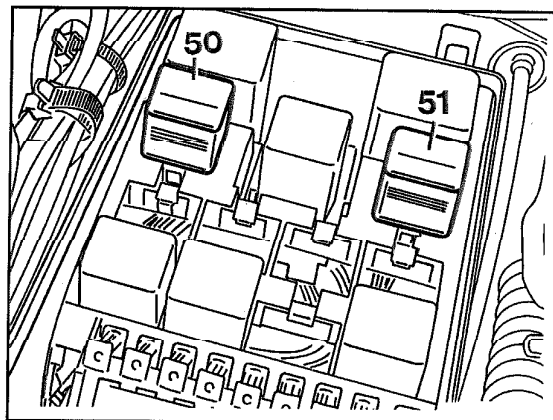

P42-2132-13

Figure 4

K1 = Overvoltage protection  
2nd version 09/81 to 08/85

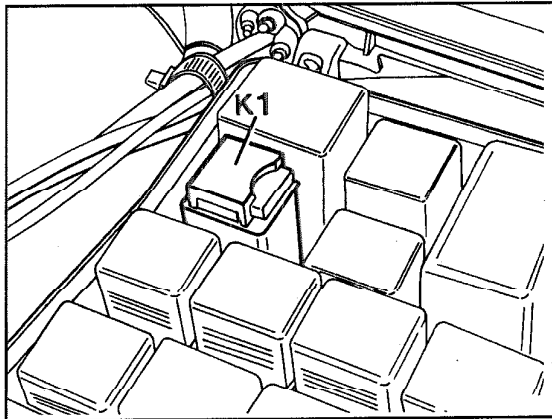

P42-2134-13

Figure 5

K1/1 Overvoltage protection  
3rd version 5-, 7- and 9-pin

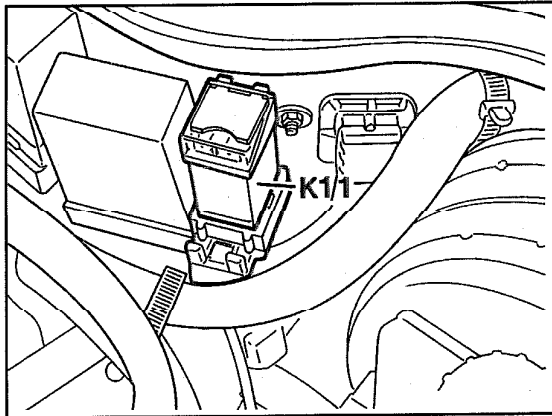

P42-2102-13

Figure 6

A = Hydraulic unit starting 01/86  
B = Hydraulic unit up to 12/85 with  
integrated diode in plug socket

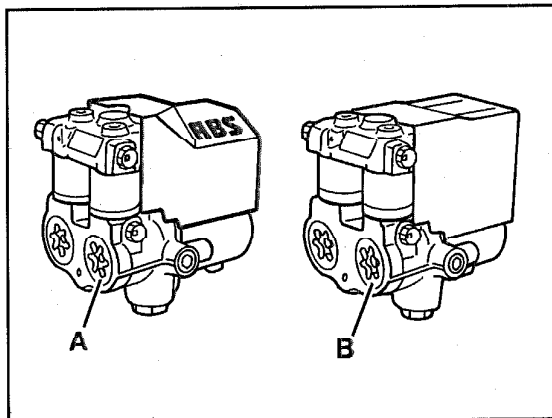

P42-2097 13

Figure 7

- L6/1 Left front wheel speed sensor
- L6/2 Right front wheel speed sensor

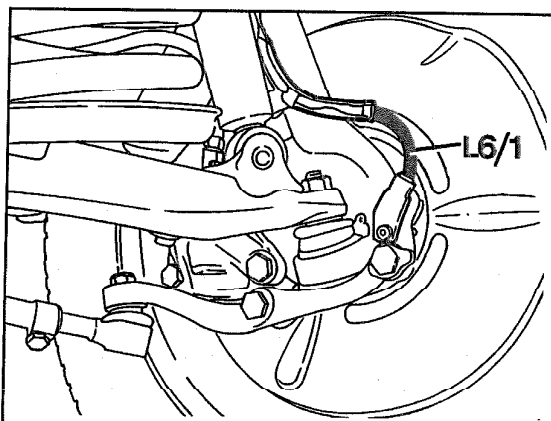

P42-2119-13

Figure 8

- L6 Rear axle speed sensor

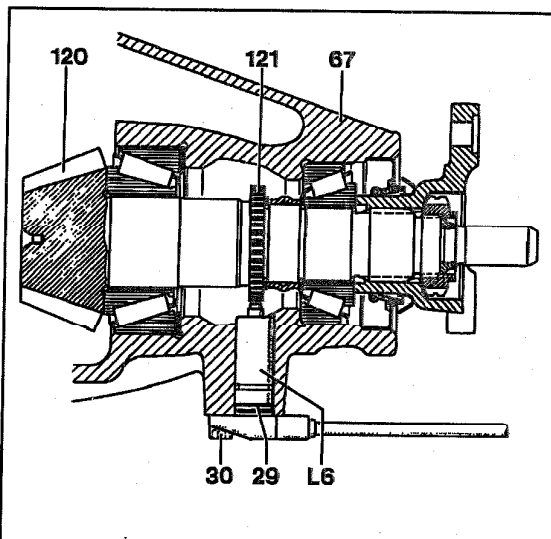

P42-0061-14

Figure 9

- 14 Ground connection on socket of hydraulic unit

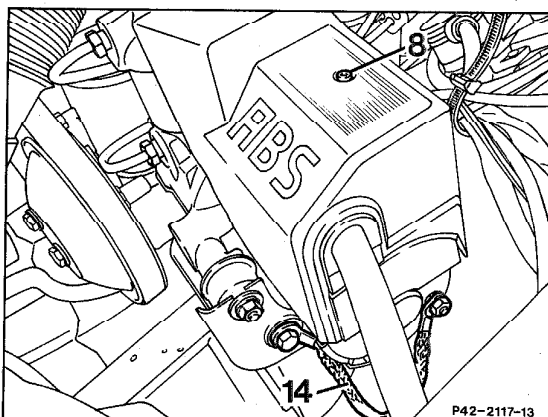

P42-2117-13

P42-2117-13

Figure 10

- 2 = Tandem brake master cylinder to front axle brake circuit (V)
- 3 = Tandem brake master cylinder to rear axle brake circuit (H)
- 4 = Hydraulic unit to front axle right (r)
- 5 = Hydraulic unit to front axle left (l)
- 6 = Hydraulic unit to rear axle (h)

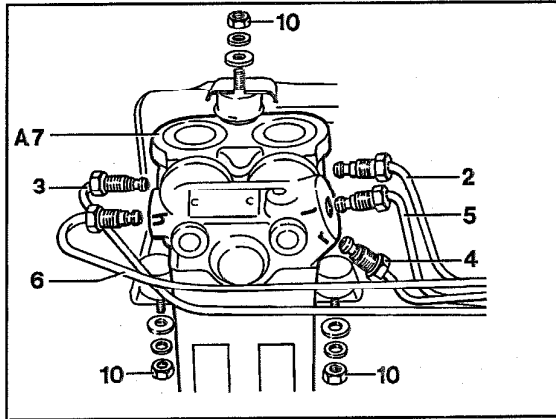

P42-0053-13

Figure 11

- L6/2x Plug connection - right front axle speed sensor (L6/1x Location mirror-image)

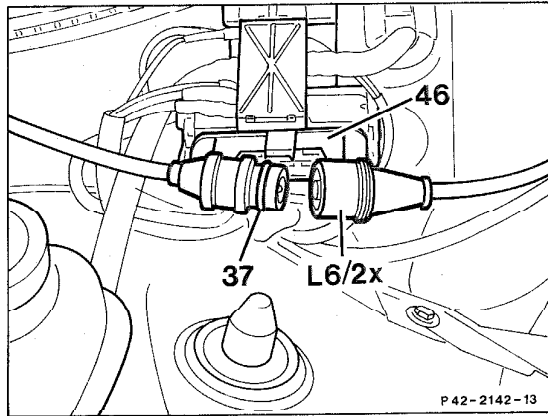

P 42 - 2142 - 13

P42-2142-13

Figure 12

- L6x1 = Cable connection - rear axle

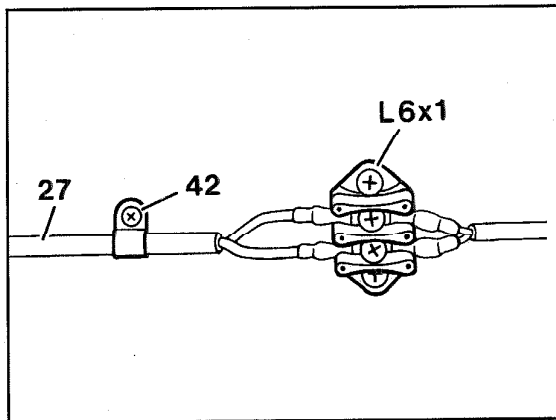

P42-2383-13

## 42-720 Electrical testing

---

### B. With Bosch tester

The Bosch tester should only be used when the test adapter 126 589 09 21 00 is not available as a special tool. Since 1986 only a test program with adapter has been prepared for all models.

#### Special tools

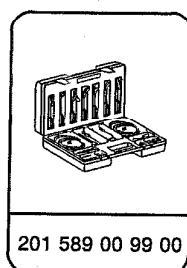
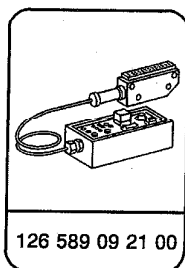
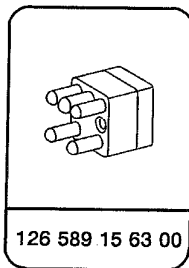

#### Commercially available tools

---

Tester

e. g. Bosch  
Model ETT 016.00

---

Multimeter

e. g. Sun, DMM-5

---

**Note**

All test steps must always be performed, starting with test step 1, except with the ABS control module with green Bosch designation plate and Bosch no. 0 265 101 011 or blue type rating plate and Bosch no. 0 265 101 016 phased in as of February 1984. This ABS control module can no longer be tested with the Bosch tester. Test steps 13, 16, 17, 18 and 19 are omitted.

As a result of the modified ABS control module the ABS cable harness is also changed, since the stop lamp switch is also included in the logic of the ABS. The stop lamp switch is connected to the 35-pin plug at pin 25 and is checked as follows:

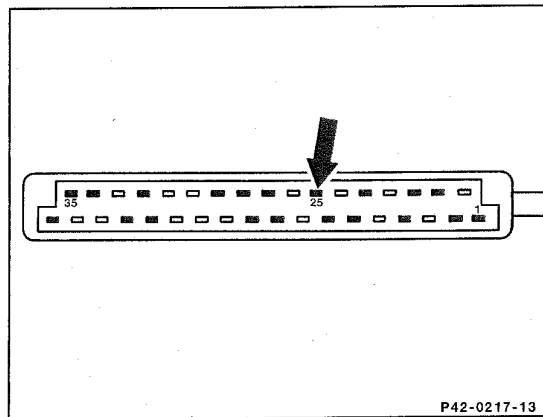

P42-0217-13  
P42-0217-13

Actuate brake and measure voltage between pin 25 and ground with a voltmeter. To prevent contact damage on the cable plug the use of a suitable connecting cable from the "electric connection set" is recommended.

## 42-720 Electrical testing

- 1 Green light (battery voltage)
- 2 Red light (battery voltage)
- 3 Green light
- 4 Red light
- 30 Digital readout
- 31 Program switch
- 32 Yellow illuminated button
- 33 Pushbutton - front wheel brake
- 34 Pushbutton - left front wheel brake
- 35 Pushbutton - right front wheel brake
- 36 Pushbutton - rear wheel brake

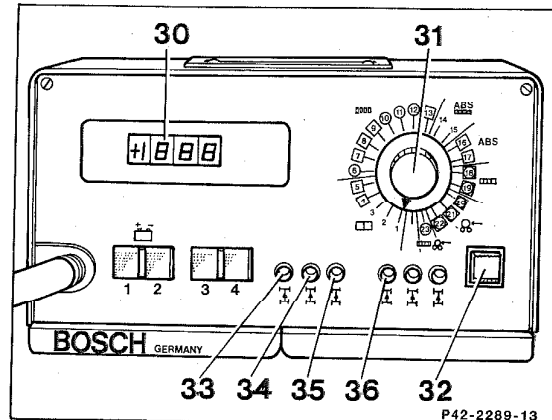

P42-2289-13

### Connection of tester

- 1 Remove ABS control module (20) with ignition switched off.
- 2 Connect multiple plug (35-pin) (21) of cable harness for ABS control module to plug (060a) of tester.
- 3 Attach plug (060b) of tester to ABS control module. The retaining spring should engage audibly in plug.

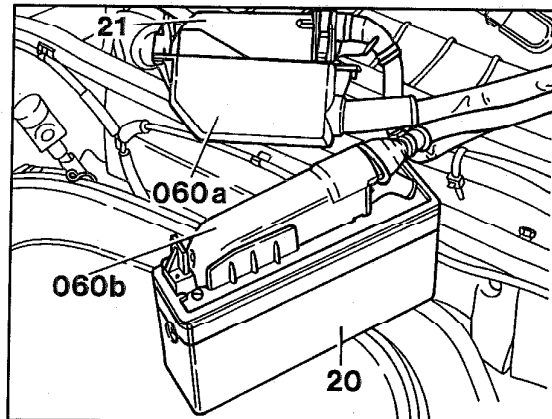

P42-2290-13

- 4 Switch on ignition, make sure that all other ancillaries are switched off.

### Note

Do not drive vehicle with tester connected.

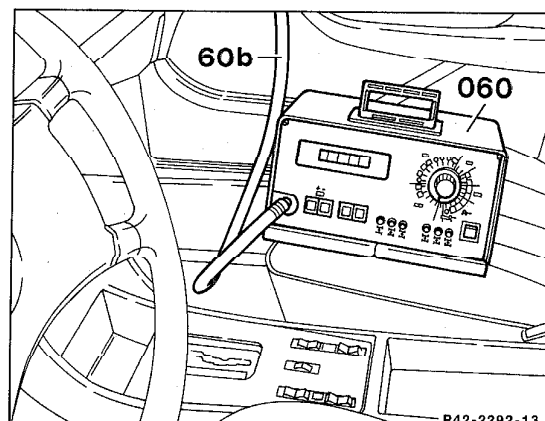

P42-2292-13

**Testing battery voltage**

(at all program switch positions).

**Note**

The battery voltage is constantly monitored during the entire test sequence. Lamps (1) and (2) are indicator lights.

If no lamp comes on, the power supply to the ABS control module and tester is interrupted.

Since September 1981 the overvoltage protection (51) and relay (50) for voltage supply of the ABS control module form one unit.

**Possible faults:**

- a) Multiple plug (35-pin) (21) not connected.
- b) Lead from battery to overvoltage protection relay interrupted (refer to electric wiring diagram).
- c) Overvoltage protection relay (51) defective (refer to test step 5).
- d) Ground line from ABS control module to overvoltage protection relay (terminal 2) interrupted.
- e) Check leads to relay (50) (refer to electric wiring diagram).
- f) Relay (50) defective.
- g) Ground line (52) to overvoltage protection relay (51) interrupted.

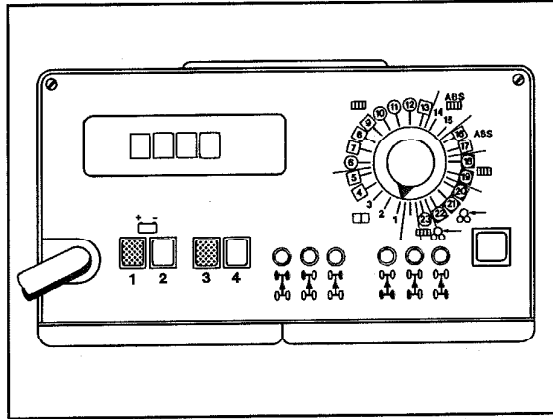

P42-0168-13

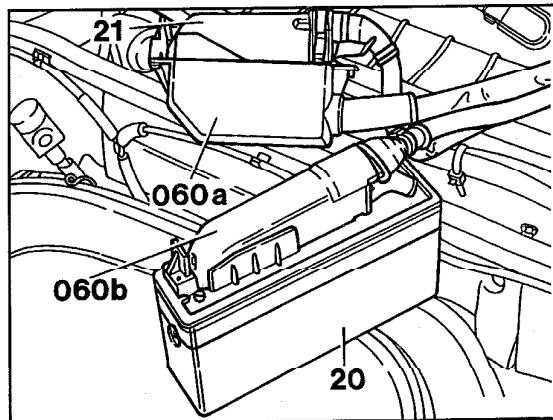

P42-2290-13

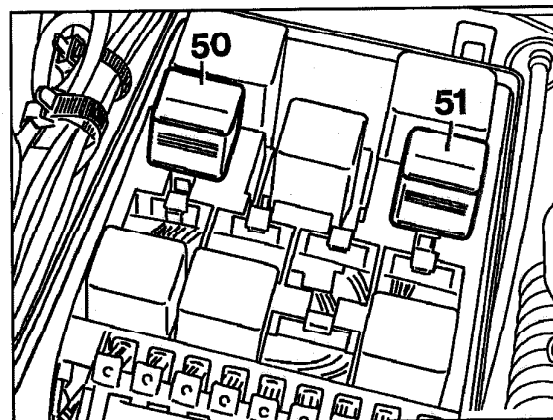

P42-2132-13

1st version up to 09/81

# 42-720 Electrical testing

If lamp (2) comes on during one of the following test steps, the supply voltage of the battery under the load of the test jobs is too low.

**Readout**

Good	Fault
Lamp 1 (green)	Lamp 2 (red)

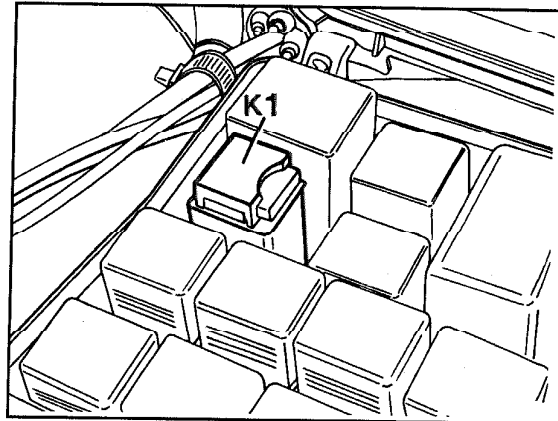

P42-2134-13

2nd version as of 09/81

1. Battery voltage < (lower) 10.5 V
2. Battery voltage > (higher) 15 V

**Remedy**

1. Check battery and recharge if required.
2. Check regulating voltage of alternator.

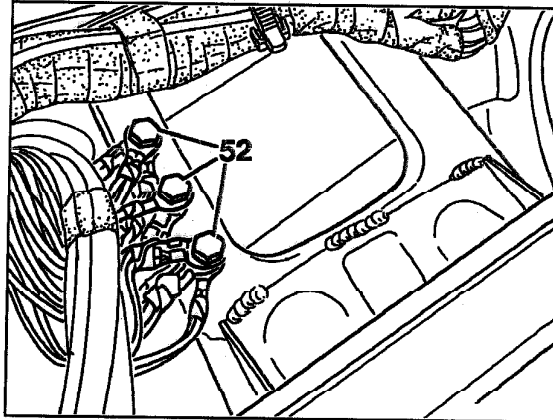

P42-2372-13

**Test step 1**

Testing solenoid valve relay (A7k1) in rest position.

**Actuation:** none

**Readout**

Good	Fault
Lamp 1 (green) Lamp 3 (green)	Lamp 4 (red)

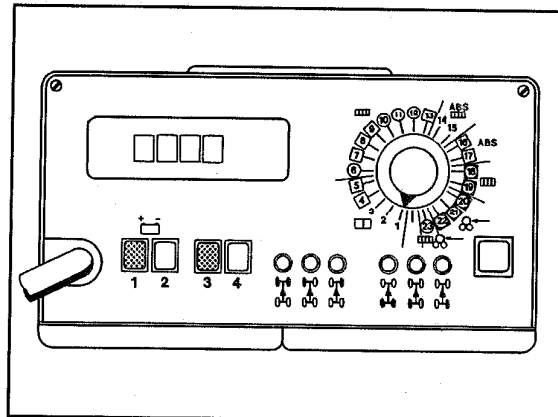

P42-0168-13

1. Poor contact of plug connection at solenoid valve relay (A7k1).
  2. Lines to solenoid valve relay interrupted (refer to wiring diagram).
  3. Solenoid valve relay (A7k1) defective.
- Remedy**
1. Check plug connection.
  2. Check lines from harness and in plug socket of hydraulic unit.
  3. Replace solenoid valve relay (A7k1).

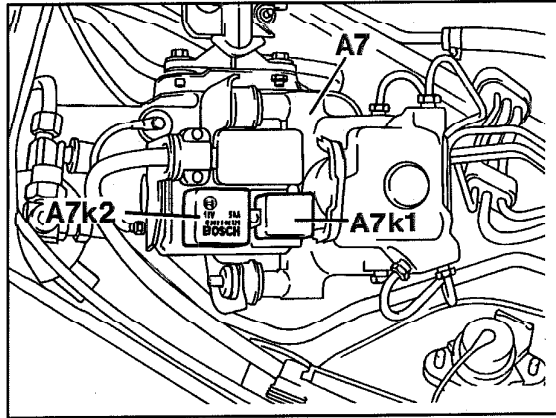

P42-2051-13A

<b>Test step 2</b> Testing the actuated solenoid valve relay (A7k1).	
<b>Actuation:</b> none	
<b>Readout</b>	
Good	Fault
Lamp 1 (green) Lamp 3 (green)	Lamp 4 (red)

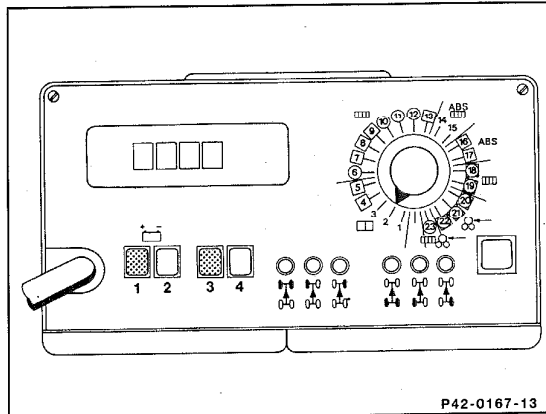

P42-0167-13  
P42-0167-13

## 42-720 Electrical testing

1. Poor contact at plug connection of solenoid valve relay (A7k1).
2. Lines to solenoid valve relay interrupted (refer to electric wiring diagram).
3. Replace solenoid valve relay (A7k1).

### Remedy

1. Check plug connection.
2. Check lines from harness and in socket of hydraulic unit.
3. Replace solenoid valve relay (A7k1).

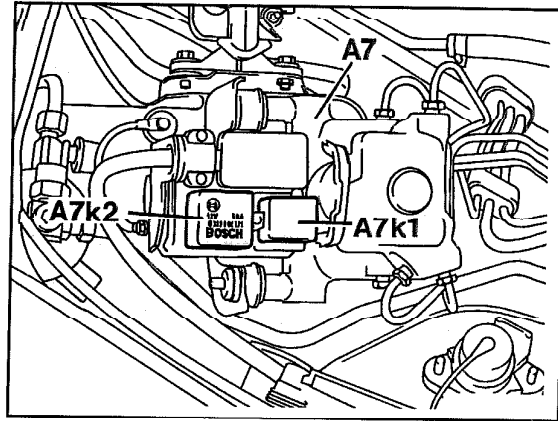

P42-2051-13A

<p><b>Test step 3</b> Testing return pump relay (A7k2) in rest position</p> <p><b>Actuation: none</b></p>	
<p><b>Readout</b></p>	
Good	Fault
Lamp 1 (green) Lamp 3 (green)	Lamp 4 (red)

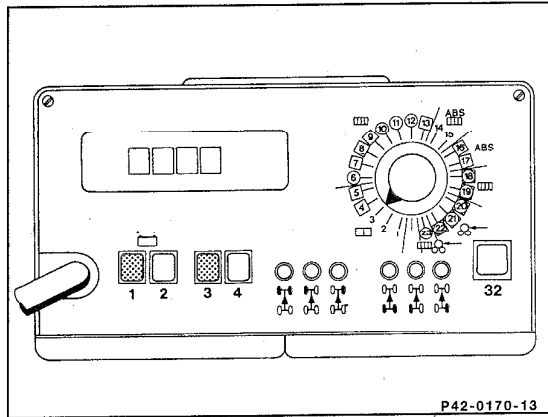

P42-0170-13

P42-0170-13

1. Poor contact at plug connection on return pump relay (A7k2).
2. Lines to return pump relay (A7k2) interrupted (refer to electric wiring diagram).
3. Grounding strap (14) or positive connection loose (visual check).
4. Return pump relay (A7k2) defective.

**Remedy**

1. Check plug connections.
2. Test lines to return pump relay (A7k2) and in plug socket of hydraulic unit.
3. Attach grounding strap or positive connection.
4. Replace return pump relay (A7k2).

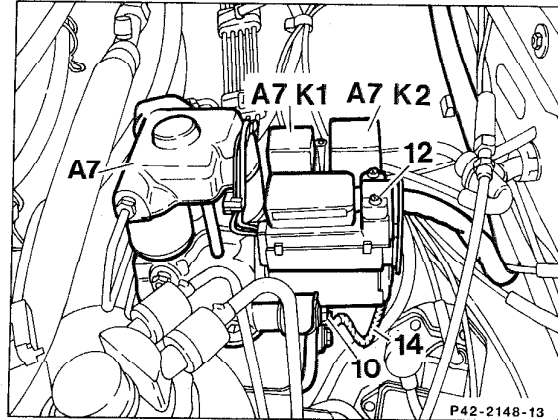

P42-2148-13  
P42-2148-13



- Remedy**
1. Check plug connection.
  2. Check lines to return pump relay (A7k2) and in plug socket of hydraulic unit.
  3. Fasten grounding strap.
  4. Replace return pump relay (A7k2).

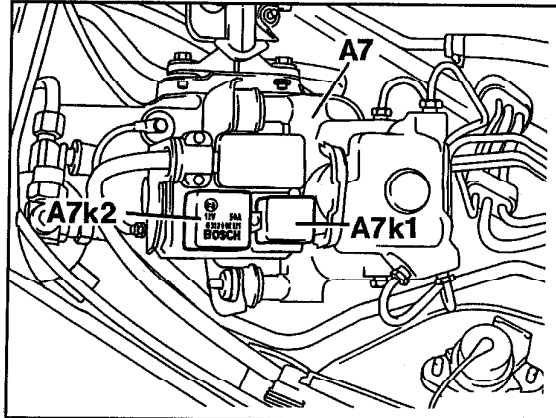

P42-2051-13A



## 42-720 Electrical testing

### Note

Overvoltage protection up to August 1981. A fusible wire (arrow) can be seen through the bore in the lower part of the overvoltage protection. The overvoltage protection may be defective even with the fuse wire intact.

### Actuation

Switch off ignition, pull out multiple plug from ABS control module. Remove overvoltage protection (51) from test socket of tester or from plug socket of vehicle.

Insert overvoltage protection relay (51 or K1/1) of tester (060) into plug socket of vehicle and overvoltage protection relay of vehicle into test socket of tester. Switch on ignition. After approx. 0.5 s, push yellow illuminated button (32). Switch off ignition. Attach multiple plug to ABS control module. Then switch on ignition again.

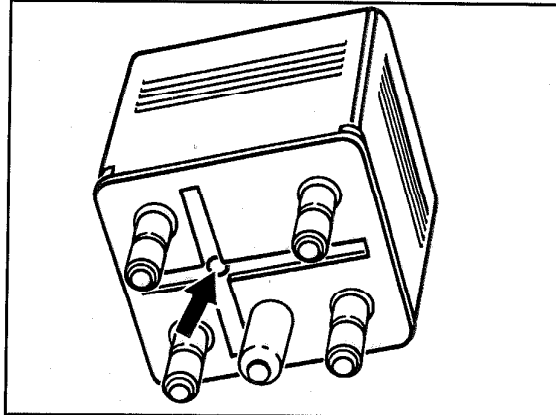

P42-2371-13

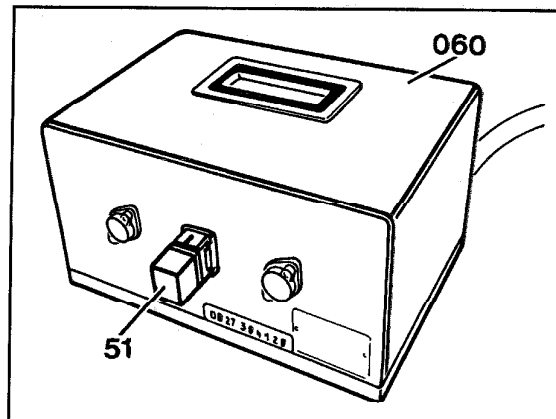

P42-2370-13

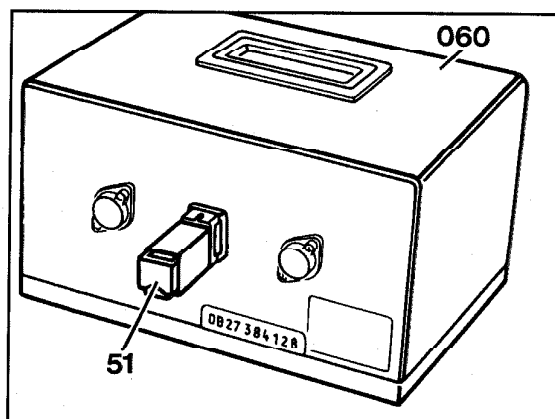

P42-2373 13

### Readout

Good

Fault

Lamp 1 (green)  
Lamp 3 (green)  
comes on following  
actuation of yellow  
illuminated button.

Lamp 4 (red)  
comes on following  
actuation of yellow  
illuminated button.  
(Repeat test step).



Overvoltage protection relay defective.

**Remedy**

Replace overvoltage protection relay (51 or K1/1).

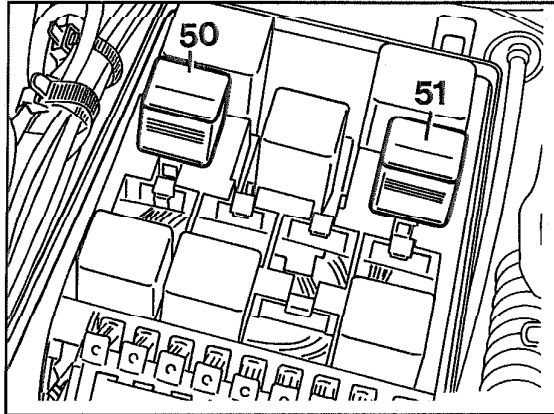

P42-2132-13

Up to 08/81

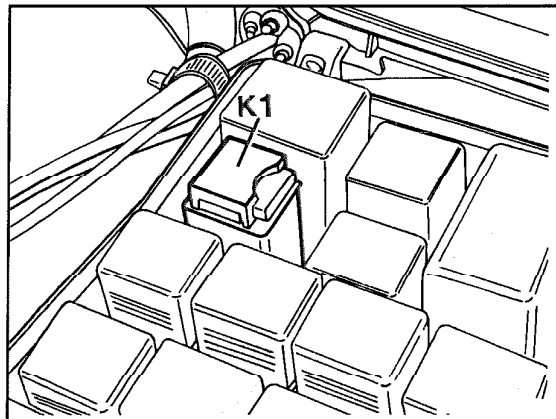

P42-2134-13

As of 09/80 to 08/85

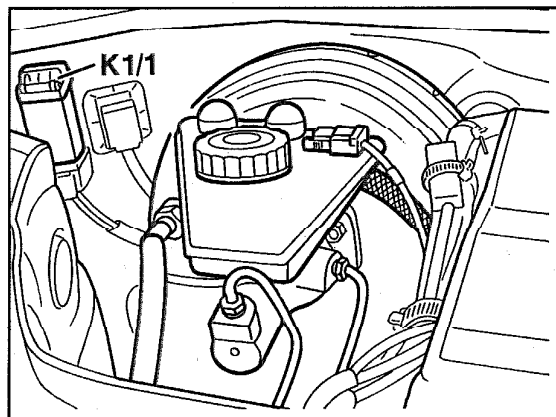

P42-2384-13

As of 09/85

### Note

Test overvoltage protection relay with 7 or 9 contact pins, installed as of 09/86, as follows:

1. Switch multimeter to measuring range for diode testing.
2. Connect relay which has been removed to multimeter, **paying attention to polarity**; connection + of multimeter to terminal 31 and connection - to terminal 30. Use electrical connection set for this purpose.

**Nominal value 0.4 to 1.5 V**

3. If the nominal value is not attained, test 10 A flat plug fuse or replace overvoltage protection relay.

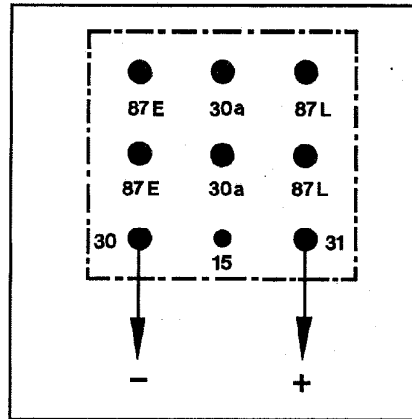

1544-14816

**Test step 6**  
Testing internal resistance of solenoid valves.

**Actuation**  
Depress pushbutton front left (34), front right (35) and rear axle (36) in sequence. Read value on tester after pushing each button.

Readout	
Good	Fault
Lamp 1 (green) Digital readout between 0.7 Ω, and 1.7 Ω	Readout: > (higher) 1.7 Ω - 999 Ω < (lower) 0.7 Ω

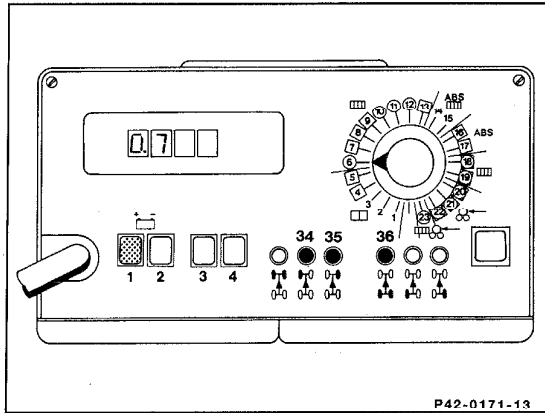

P42-0171-13

1. Poor contact at plug connection on hydraulic unit.
2. Lines to respective valve interrupted (refer to electric wiring diagram). Lines in plug socket of hydraulic unit interrupted.
3. Respective valve has short circuit or interturn ground connection.

**Remedy**

1. Check plug connections and spray with contact spray, if required.
2. Check lines, including those in plug socket of hydraulic unit.
3. Replace hydraulic unit.

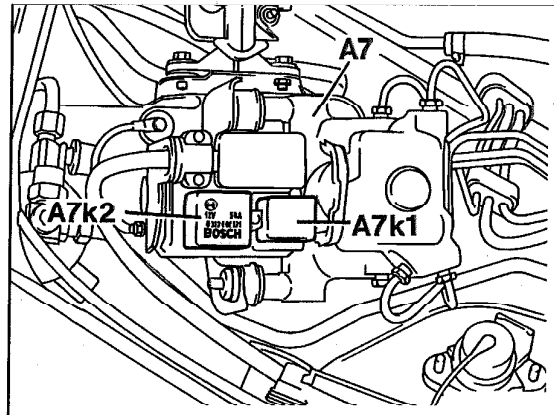

P42-2051-13A

<p><b>Test step 7</b> Testing ground connection from overvoltage protection relay to ABS control module terminal 10.</p> <p><b>Test step 8</b> Ground connection from ground point (52) to ABS control module terminal 34.</p> <p><b>Test step 9</b> Ground connection from ground point (52) to ABS control module terminal 20.</p> <p><b>Actuation</b> Press yellow illuminated button (32).</p>	
<p><b>Readout</b></p>	
Good	Fault
<p>Lamp 1 (green) Digital readout:</p> <p><b>Test step 7</b> between 110 mV- 300 mV</p> <p><b>Test steps 8 and 9</b> between 40 mV- 250 mV</p>	<p>Readout:</p> <p>&gt; (higher) 300 mV &lt; (lower) 110 mV</p> <p>&gt; (higher) 250 mV &lt; (lower) 40 mV</p>



**Test steps 7, 8, 9**

Lines from ground point (52) to ABS control module terminal 10, 34, 20 poor contact or interrupted or ground terminal on overvoltage protection relay has poor contact or is interrupted (refer to electric wiring diagram).

**Remedy**

Check ground connections, tighten if necessary.

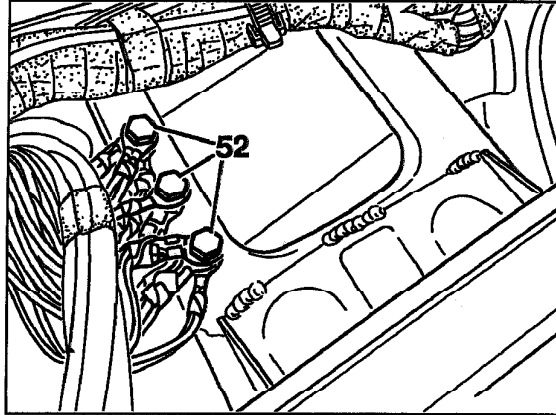

P42-2372-13

**Test step 10**

Testing internal resistance of wheel speed sensors.

**Actuation**

Depress pushbuttons front left (34), front right (35) and rear axle (36) in sequence.

After pushing each button, read value on tester.

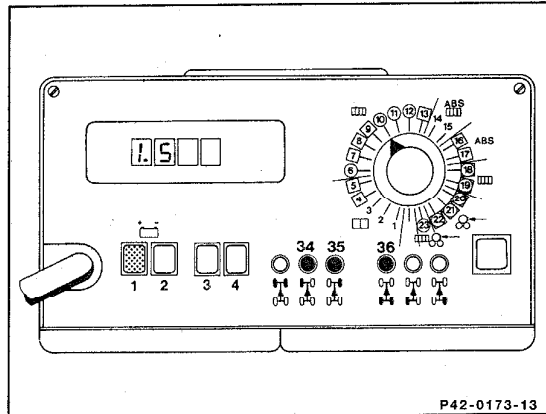

P42-0173-13

P42-0173-13

**Readout**

Good

Fault

Lamp 1 (green)

Readout:  
Front axle

Digital readout for:  
Front axle  
0.85 kΩ - 2.3 kΩ

< (lower) 0.85 kΩ  
> (higher) 2.3 kΩ

Rear axle  
0.6 kΩ - 1.6 kΩ

Rear axle  
< (lower) 0.6 kΩ  
> (higher) 1.6 kΩ

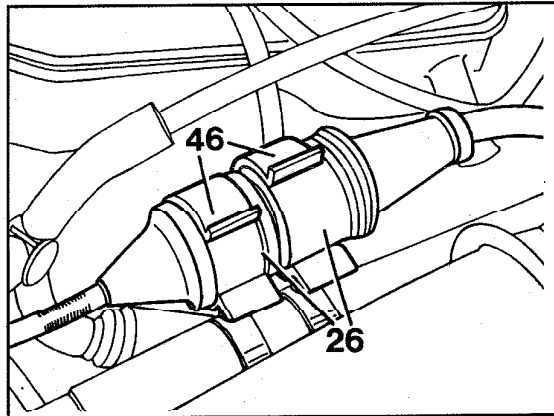

P42-2133-13



1. Poor contact at coaxial plugs (26) or cable connector (L6x1).
2. Line to respective wheel speed sensor interrupted.
3. Wheel speed sensor defective.

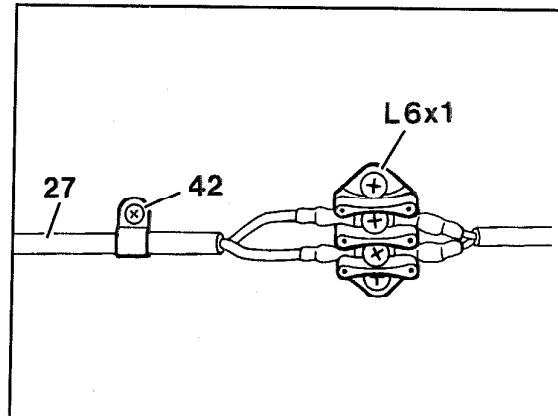

P42-2383-13

**Remedy**

1. Test coaxial plugs or plug connector.
2. Pull off both coaxial plugs (26) and test lines to ABS control module.

Disconnect lines on cable connector (L6x1) and test.

3. Replace appropriate wheel speed sensor.

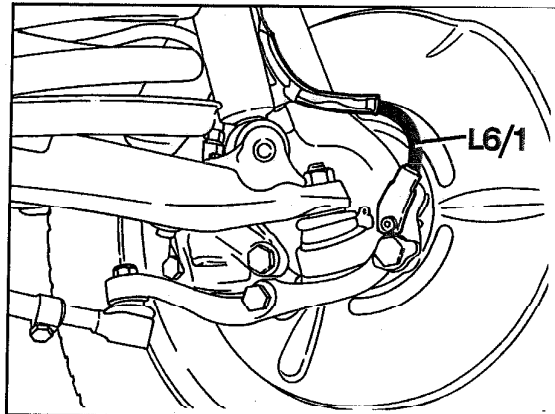

P42-2119-13

**Test step 11**

Testing insulation resistance of wheel speed sensors against ground.

**Actuation**

Depress pushbuttons front left (34), front right (35) and rear axle (36) in sequence.

After pushing each button, read value on tester.

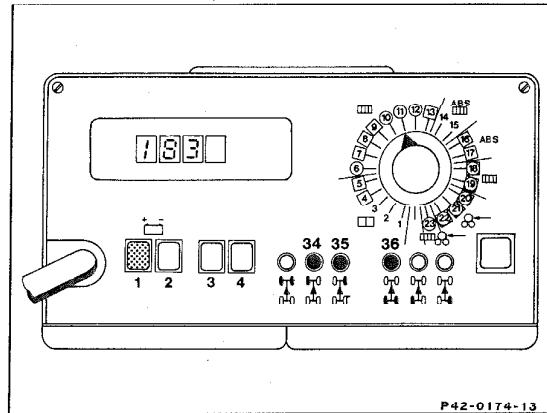

Readout	
Good	Fault
Lamp 1 (green) Digital readout: > (higher) 20 kΩ (max. 999 Ω)	Readout: < (lower) 20 kΩ

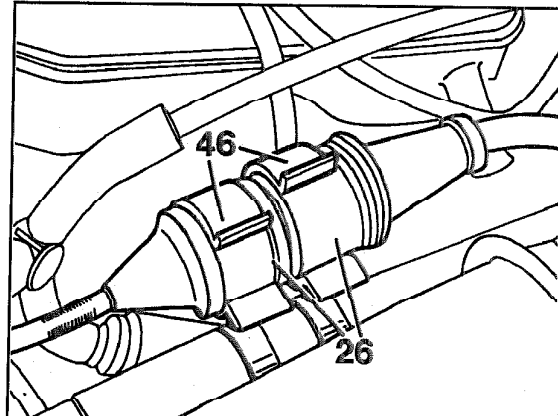

P42-2133-13

1. Line to respective wheel speed sensor has short-circuit to ground.
2. Coaxial plug or cable connector has short-circuit to ground.
3. Wheel speed sensor has short-circuit to ground.

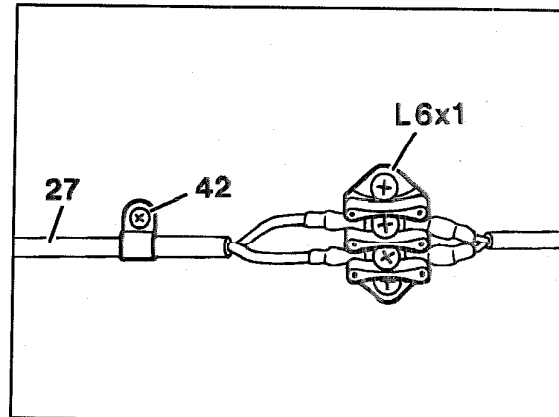

P42-2383-13

- Remedy**
1. Test line to wheel speed sensor.
  2. Test coaxial plugs or cable connector.
  3. Replace appropriate wheel speed sensor.

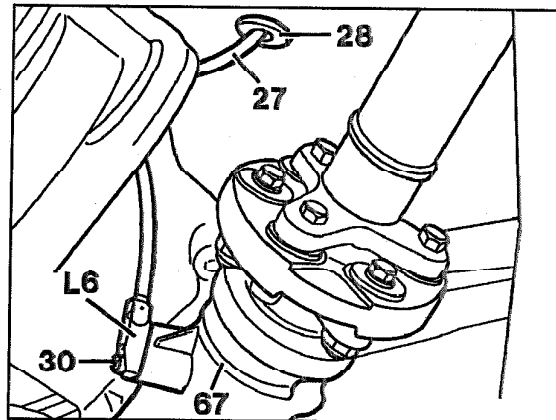

P42-2382-13

**Test step 12**

Testing insulation resistance of wheel speed sensors against supply voltage.

**Actuation**

Depress pushbuttons front left (34), front right (35) and rear axle (36) in sequence.

After pushing each button, read value on tester.

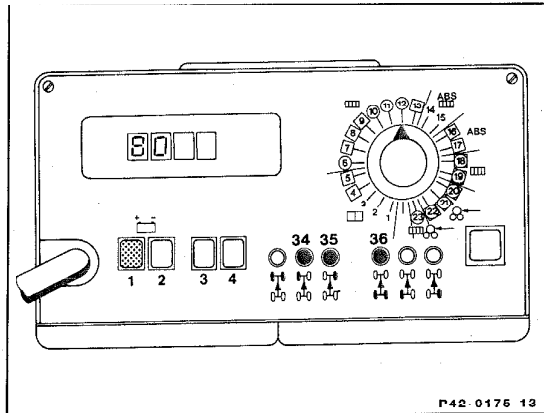

P42-0176-13  
P42-0175-13

**Readout**

Good	Fault
Lamp 1 (green) Digital readout: between 0-100 mV	Readout: > (higher) 100 mV (max. 999)

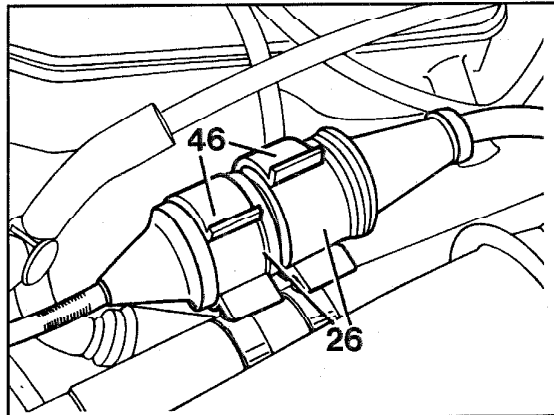

P42-2133-13

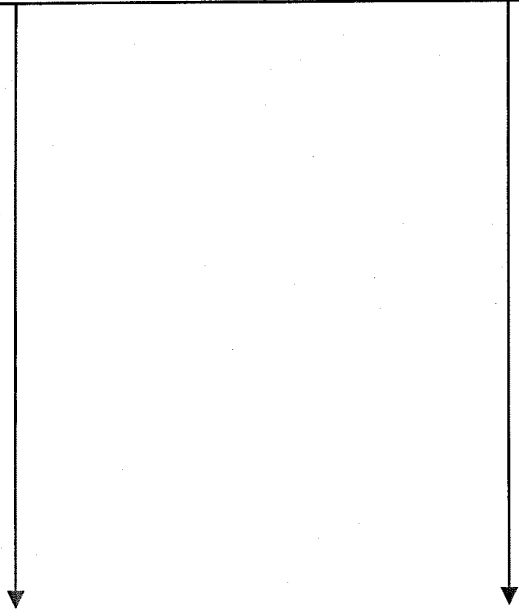



ABS control module defective.

**Remedy**  
Replace ABS control module (N30).



## 42-720 Electrical testing

<b>Test step 14</b> Testing function of ABS indicator lamp. (Diode in flow direction).	
<b>Actuation</b> none	
<b>Readout</b>	
<b>Good</b>	<b>Fault</b>
Lamp 1 (green) ABS indicator lamp comes on. Digital readout: between 0.4-1.5 V	ABS indicator lamp does not come on. Readout: < (lower) 0.4 V > (higher) 1.5 V

1. Indicator lamp defective.
2. Line from plug socket (13a) of hydraulic unit (terminal 7) to 35-pin multi-plug (terminal 29) of ABS control module (N30) interrupted (refer to electric wiring diagram).
3. Diode in plug socket (13a) of hydraulic unit or in solenoid valve relay (A7k1) interrupted or short circuit.