

P41-0006-33

- |   |  |
|---|--|
| Drive shaft .....   | remove and install (41-050).   |
| Front and rear drive shaft (1,2) .....                                      | separate, plug together (step 2).  |
| Rubber sleeve (4) .....   | pull on and off (step 3).  |
| Rubber mount (7) with grooved ball bearing (8) and protective cap (6) ..... | pull off, press on, remove locking ring (5) on vehicles up to 07/82.<br>Two-legged puller 000 589 88 33 00 with pulling legs 116 589 03 33 00, pressing-on sleeve 126 589 03 15 00 (steps 4 to 7). |
| Rear protective cap (6a) .....  | remove, plug on (step 8).  |

## 41-100 R and R center bearing

Grooved ball bearing (8) .....	press out of and in rubber mount (7), check and replace if required. Pressing-out, pressing-in tool 116 589 09 43 00 (steps 9 to 11).
Spline shaft profile (28) .....	grease with specified grease (refer to Specifications for Service Products page 266.2).

### Special tools

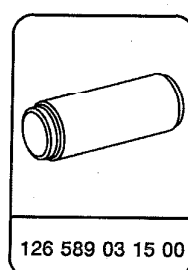
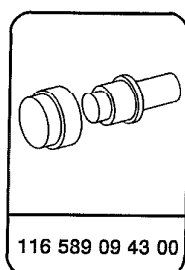
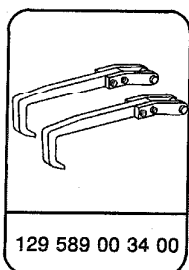
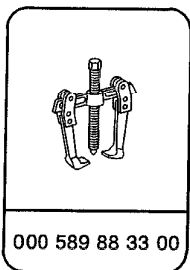

- 1 Remove drive shaft (41-050).
- 2 Separate front and rear drive shaft at clamp connection.

#### Note

On vehicles starting 08/82 the front and rear drive shaft are shown in relation to each other (arrows).

The drive shaft components are individually pre-balanced at the factory. To eliminate any residual unbalance which might still be present, the complete drive shaft including the flexible couplings, is rebalanced. For this reason, when disassembling the complete drive shaft (e.g. when changing the drive shaft intermediate bearing) the individual parts must be marked in relation to each other (if no markings are in place) for correct reassembly.

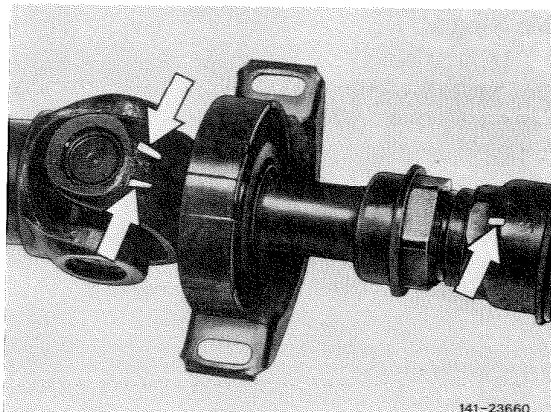

141-23660  
141-23660

On vehicles up to 07/82, mark the individual drive shaft parts in relation to each other (arrows).

**Installation note**

Grease spline shaft profile with specified grease (refer to factory approved service products list).

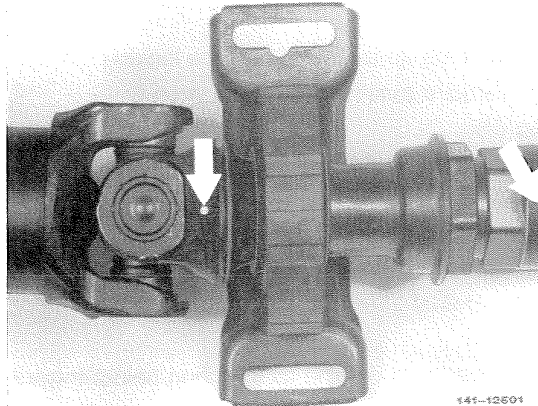

141-12591

141-12591

3 Pull off rubber sleeve (3) via serrations.

**Installation note**

Pay attention to correct seat of rubber sleeve on small diameter.

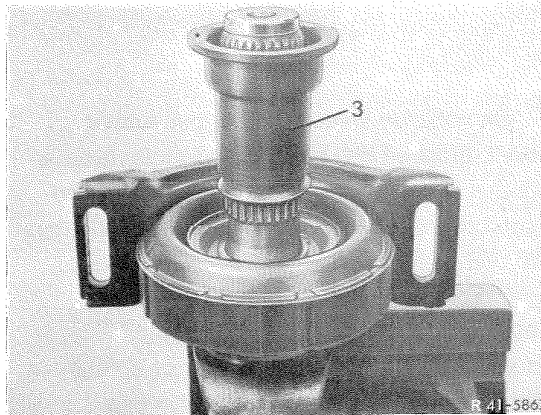

R 41-5867

R41-5867

4 On vehicles up to 07/82, pull rubber mount and grooved ball bearing together with two-legged puller 000 589 88 33 00 from fork-type joint.

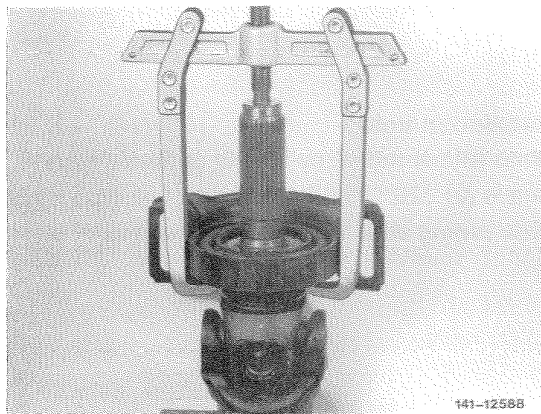

141-12588

141-12588

## 41-100 R and R center bearing

### Note

On vehicles up to 07/82, remove locking ring (5) and remove together with front protective cap (6).

### Installation note

Insert locking ring (5) into groove of fork-type joint in such a manner that the protective cap rests against bearing inner race.

The inner hump of the locking ring points toward protective cap.

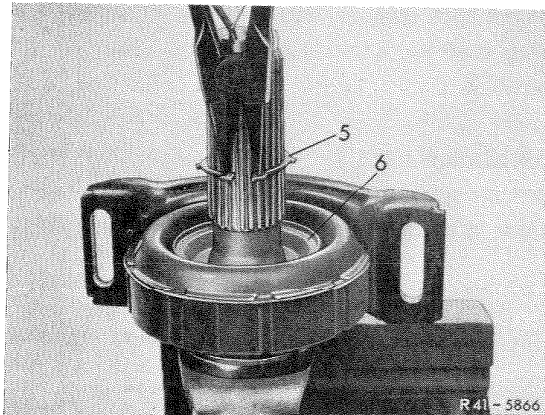

R41-5866

5 On vehicles starting 08/82, pull rubber mount, grooved ball bearing and protective cap together from fork-type joint by means of two-legged puller 000 589 88 33 00 and pulling legs 116 589 03 33 00.

### Note

On vehicles starting 08/82, the grooved ball bearing is secured by the protective cap.

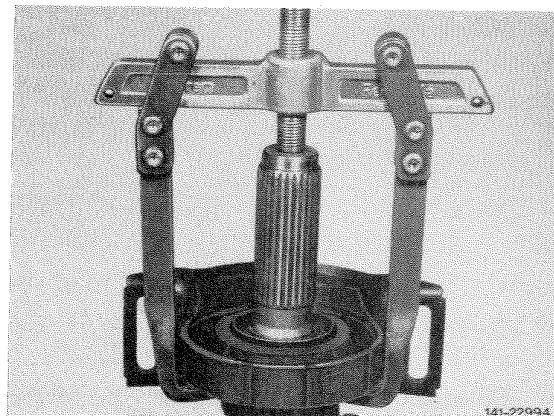

141-22994

### Installation note

Press rubber mount by means of pressing-on sleeve (3) 126 589 03 15 00 onto fork-type joint, while paying attention to correct location of V-fold.

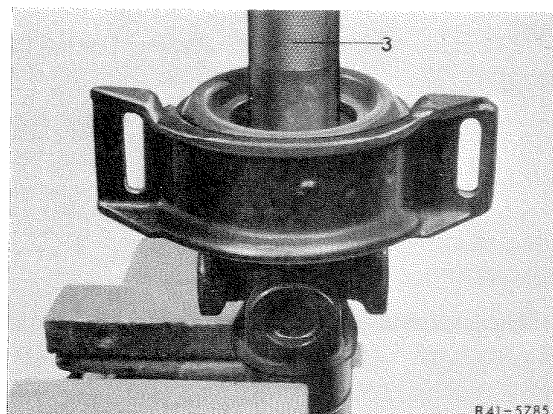

R41-5785

## 41-100 R and R center bearing

6 Install rubber mount with inner V-fold. Install rubber mount in such a manner that the inner V-fold points toward universal joint.

1st version up to 07/82

- 1 Front drive shaft
- 2 Rear drive shaft
- 3 Clamping nut
- 4 Rubber sleeve
- 5 Locking ring
- 6 Protective cap
- 7 Drive shaft intermediate bearing
- 8 Grooved ball bearing
- 9 Fork-type joint
- 15 Universal joint star with needle bearing and bushings
- 16 Frame floor
- 17 Drive shaft tunnel

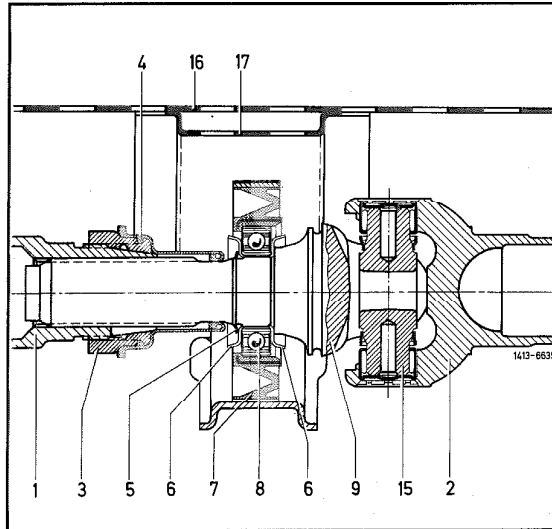

1413-6639

7 Mount self-locking protective cap (on vehicles starting 08/82) with pressing-on sleeve 126 589 03 15 00 making sure that the protective cap rests against grooved ball bearing (8) (cutout in Fig.).



Use pressed-on protective cap only once.

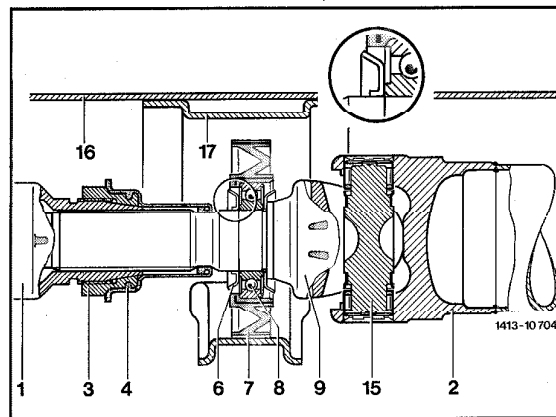

1413-10704

8 Remove rear protective cap (arrow) from fork-type joint.

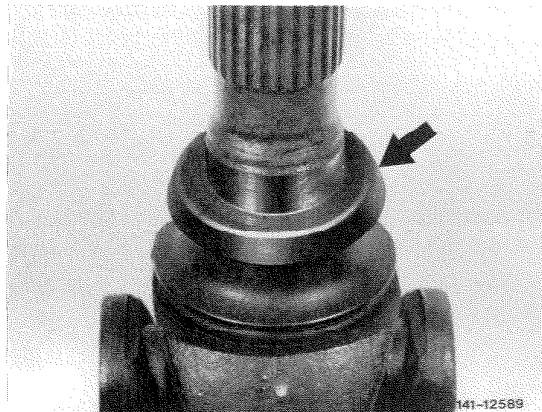

141-12589

141-12589

## 41-100 R and R center bearing

### Replacing grooved ball bearing

9 Press grooved ball bearing (8) with removing and pressing-in tool (04) 116 589 09 43 00 out of rubber mount (7).

10 Check rubber mount and grooved ball bearing for wear and replace parts, if required.

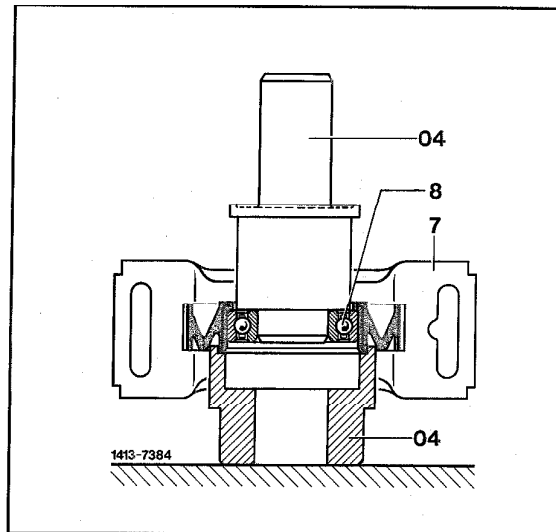

1413-7384

11 Press grooved ball bearing (8) into rubberized bearing seat up to contact surface (arrows).

#### Note

Pay attention to correct seat of grooved ball bearing.

12 For further installation proceed vice versa starting at step 8.

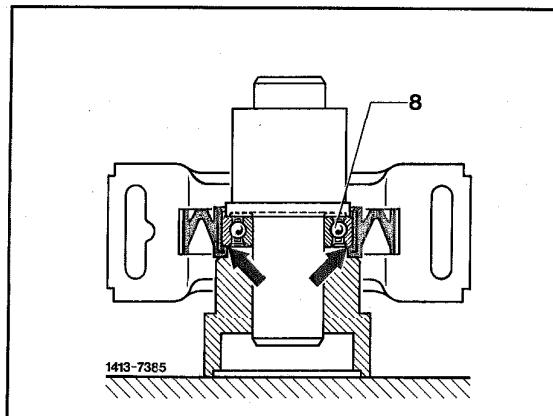

1413-7385