

**Notes**

- Identical version wheels only should be fitted to a vehicle.
- Use only wheels approved by the company. The part no. provided next to the general designation is always decisive in case of doubt.

Designation and part no. are provided on the wheel disk (on steel wheels outside, on light alloy wheels inside).

A trademark (three-pointed star in ring) is stamped as additional identification into steel wheels starting 07/73 and from start of production into light-alloy wheels.

- The additional identification "A" for symmetrical rim cross section and "B" for asymmetrical rim cross section is no longer used for the current passenger car wheels as all wheels are of the asymmetrical type. Mercedes-Benz asymmetrical wheels have a standard hump on the outside and inside.

Wheels with only one hump on the outside carry the code letter "H". During air loss of the tire, the hump prevents that the tire bead slides down into the low rim bed, i.e. sudden deflation of the tire. At least one hump on the rim outside is required when using tubeless tires.

- If vehicles are converted to another wheel designation approved by the company in connection with a change of the tire designation, country-specific rules and regulations must be observed prior to the conversion.
- Wheel trim covers must be mounted on steel wheels in order to support the rubber valve.
- No rust marks are allowed on the seat of the tire bead at the radius to the rim flange and on the rim flange itself as well as the outer surfaces especially on the inside of steel wheels.

# 40-0102 Wheels

## Wheels designation

Example:

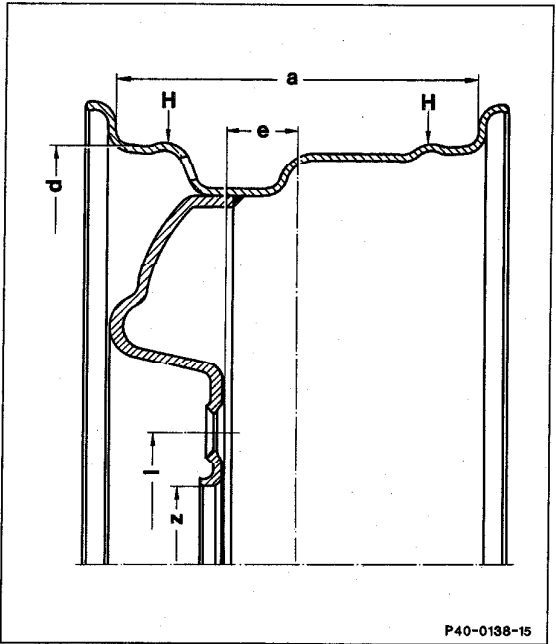
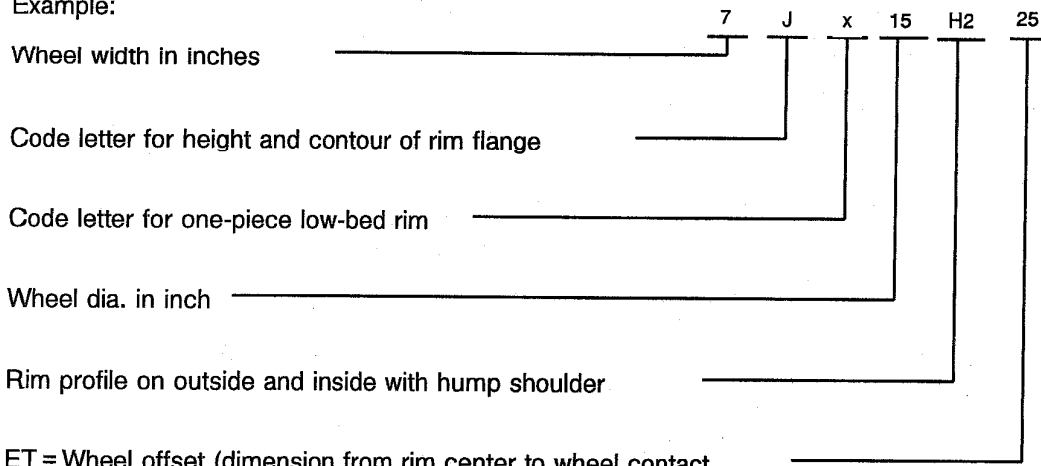

### Steel and light-alloy wheels

- a Wheel width in inch
- d Wheel dia. in inch (measuring point dia.)
- e Wheel offset ET  
(distance from rim center to contact surface of wheel disk, measured in mm)
- l Pitch circle dia. = 112 mm
- z Centering bore dia. = 66.5 ± 0.1 mm
- H Hump (rim with safety shoulder)

P40-0138-15

P40-0138-15

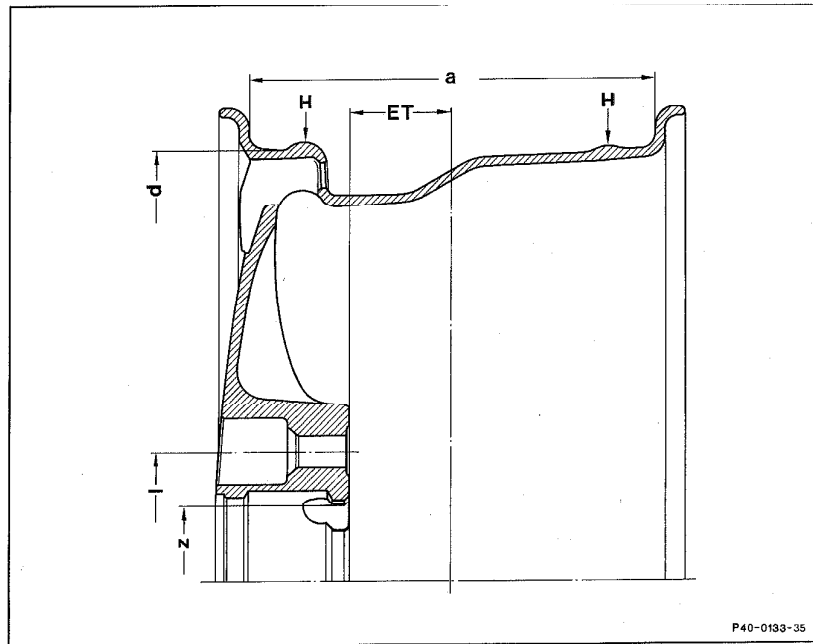

P40-0133-35

P40-0133-35

**Wheel designation**

1. Wheel designation, e.g. 6 J x 14 H2 ET 30.
2. Part no., e.g. 108 400 14 02.
3. Identification as Mercedes-Benz part.
4. Production code figure or manufacturing date.
  - a) Production identification with month/year through 02/78, e.g. = January 1978.
  - b) Production identification with week/year starting 03/78, e.g. 13 78 = 13th week 1978.

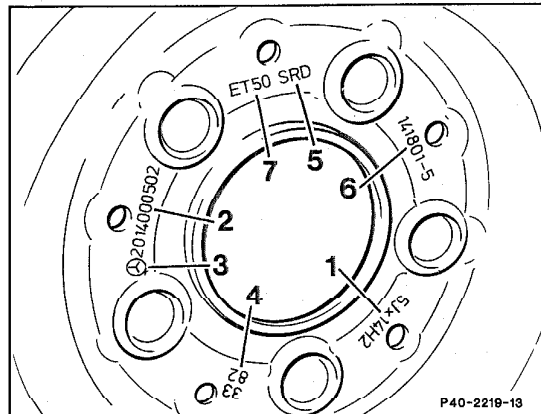

P40-2219-13

P40-2219-13

Identification of steel wheels outside

## 40-0102 Wheels

---

5. Manufacturer's trademark, e.g. SRD (SÜDRAD).
6. Part no. of manufacturer.
7. Wheel offset - ET  
Identification of wheel offset:
  - a) On steel wheels as of production code figure 41 81.
  - b) On light-alloy wheels as of production code figure 32 81.

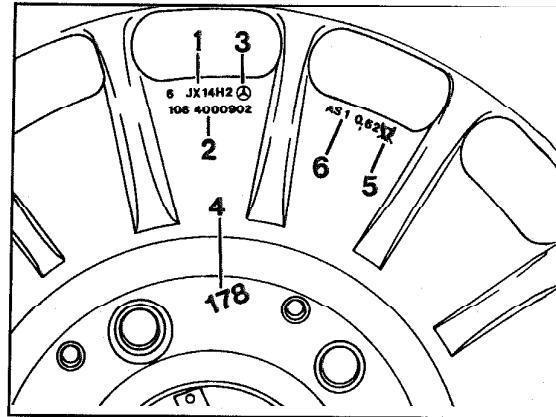

P40-2231-13

Identification of light-alloy wheels inside

## Steel wheels

### Note

No rust marks should be present on the seat of the tire bead at the radius to the rim flange and on the rim flange itself as well as the outer surfaces especially on the inside of steel wheels. Before inserting a new rubber valve, clean contact surfaces on the rim. If required, remove rust from surfaces and repaint.

Especially in the winter season, inspect rim inside for accumulation of dirt and clean if necessary.

For steel wheels the mounting eye version is decisive for exact wheel mounting. Raised mounting eyes provide better protection against excessive tightening of the wheel bolts than the sunk mounting eyes used in earlier wheels.

Wheels the mounting eyes of which have inadequate inner distance to the contact surface due to repeated excessive tightening of the wheel bolts must not be installed.

The distance between the contact surface and the area of the mounting eyes must be at least 0.7 mm on a removed wheel. Use a straightedge and vernier with depth gauge for measuring.

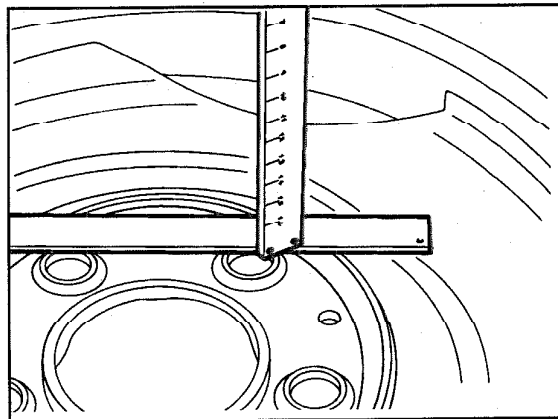

P40-2208-13

## 40-0102 Wheels

### 14" steel wheels

Designation	Wheel offset ET mm	Part no.	Model	Remarks
6 J x 14 H2	30	126 400 06 02 replacement for 123 400 16 02	126.02	with inner ventilation ring – wheel disk with 18 ventilation holes of 25 mm dia.

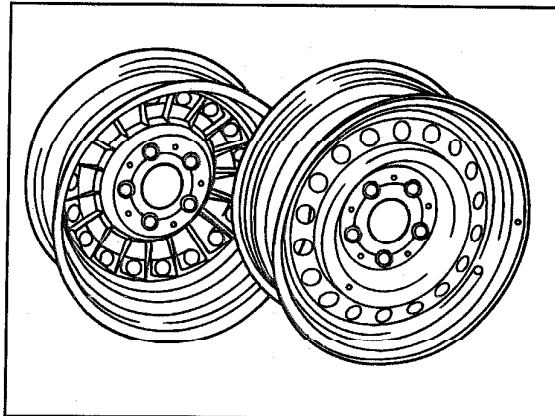

P40-2240-13

## 40-0102 Wheels

Designation	Wheel offset ET mm	Part no.	Model	Remarks
6 1/2 J x 14 H2	30	126 400 07 02	126.03	Version starting 01/80 with inner ventilation ring – wheel disk with 18 ventilation holes of 25 mm dia.

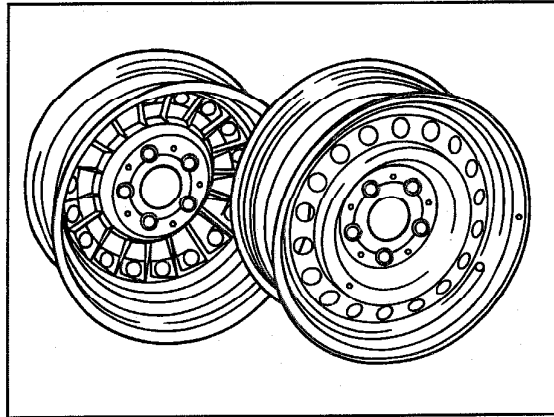

P40-2249-13

Designation	Wheel offset ET mm	Part no.	Model	Remarks
6 1/2 J x 14 H2	30	126 400 15 02	126.04	Without inner ventilation ring – wheel disk with 18 ventilation holes of 25 mm dia.

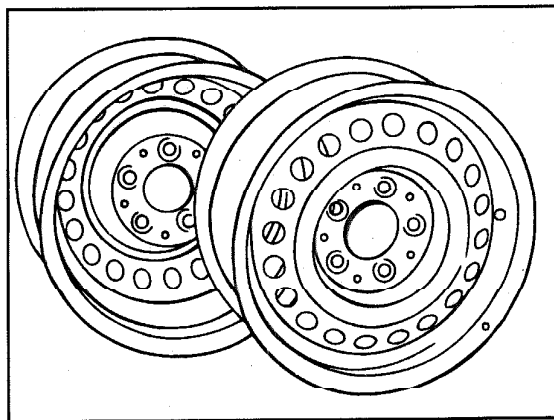

P40-2232-13

## 40-0102 Wheels

### 15" steel wheels

Designation	Wheel offset ET mm	Part no.	Model	Remarks
7 J x 15 H2	25	126 400 28 02	126	Without inner ventilation ring – wheel disk with 20 oval ventilation holes and with matchpoint (arrow). Phased-in starting 01/90 with segment centering.

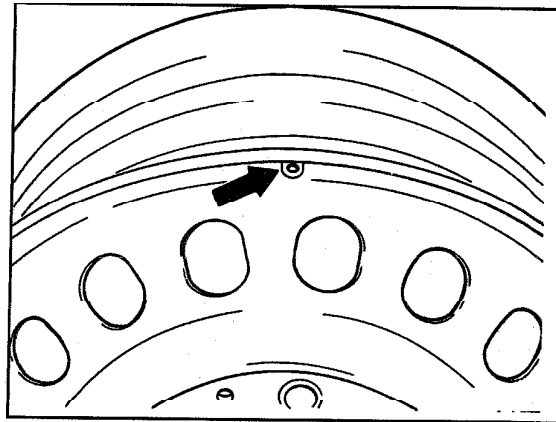

P40-2216-13

## Light-alloy wheels

### Notes

- The rim flanges of light-alloy wheels can show increased wear under the following operating conditions: High load, trailer operation, inadequate tire inflating pressure, use of tire makes or tire versions not recommended, dirt, sand and road salt. The rim flanges must be inspected for wear before fitting a new tire. Burrs must be removed. When the wear limit has been reached, replace the wheel (40-120).

Especially during the winter season, inspect wheels on the inside for accumulation of dirt and clean if required.

### Care and cleaning of light-alloy wheels

Light-alloy wheels have a special metallic paint finish. For this reason, they should, like the body, be only treated and cleaned with mild agents not attacking the paintwork. A damage of the clear varnish surface can lead to flaking off.

For this reason observe the following for cleaning:

1. Never use abrasive, acetic or severely alkaline agents or scouring sponge to clean light-alloy wheels.
2. Clean the wheels as required, preferably weekly. Ordinary dirt including brake lining abrasion can be removed with plenty of

lukewarm water, a mild dirt removing agent (as used on the body) and a sponge.

If cleaning of the wheels together with the vehicle wash is not adequate, special cleaning agents are available for light-alloy wheels. These should be used after previous cleaning with water.

3. When cleaning the light-alloy wheels with a high-pressure cleaning machine observe the following:
  - a) Use only high-pressure cleaning machine with 25° flat spray nozzle.

### CAUTION!

Do not use round spray nozzle.

- b) Maintain a minimum distance of approx. 300 mm from the flat spray nozzle to the light-alloy wheel for cleaning and move nozzle to and fro.
- c) If other nozzles are used or the required distance is not maintained, damage may result on the light-alloy wheel or, on the road wheel, also on the tire.

Damage can be caused even at an action time of less than 1 second and a distance of less than 700 mm.

4. If light-alloy wheels have to be repainted, using methods applied for body painting.

## 40-0102 Wheels

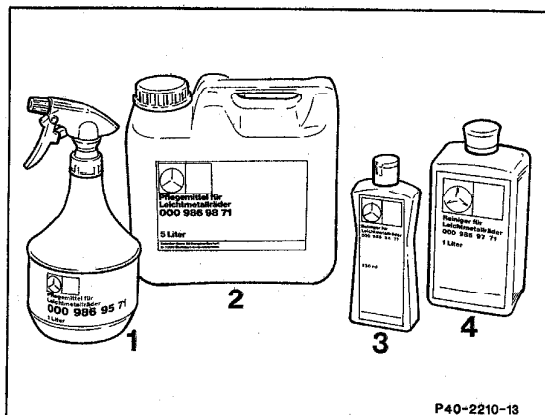

P40-2210-13

P40-2210-13

### Preservative and cleaning agents for light-alloy wheels

Designation		Part no.
Preservative agent	1 liter spray bottle (item 1)	000 986 95 71
	5 liter can (item 2)	000 986 98 71

Suitable for regular treatment of wheels even when very dirty, however not to remove stubborn dirt.

Has a preserving effect.

### Preserving and cleaning agents for light-alloy wheels

Designation		Part no.
Cleaning agent	1/4 liter bottle (item 3)	000 986 94 71
	1 liter bottle (item 4)	000 986 97 71

To remove stubborn dirt which cannot be removed with preservative agent for light-alloy wheels. After cleaning with this agent preserve with gloss preserving agent or preserving agent for light-alloy wheels 000 986 95 71.

**14" forged light-alloy wheels**

Designation	Wheel offset ET mm	Part no.	Model	Remarks
6 J x 14 H2	30	108 400 09 02 <sup>1)</sup>	126 (through 08/85)	Parts kit 108 400 21 02 <sup>1)</sup> <sup>3)</sup>
		126 400 19 02 <sup>2)</sup>		Parts kit 126 400 23 02 <sup>2)</sup> <sup>4)</sup>
6 1/2 J x 14 H2	30	108 400 10 02 <sup>1)</sup>	126 (through 08/85)	Parts kit 108 400 22 02 <sup>1)</sup> <sup>3)</sup>
		126 400 21 02 <sup>2)</sup>	126 (through 08/85)	Parts kit 126 400 24 02 <sup>2)</sup> <sup>4)</sup>

- 1) Version through 09/81 (without trough around valve seat – for special metal valve).
- 2) Version starting 10/81 (with trough around valve seat – for rubber valve).
- 3) Parts kit includes: wheel, wheel cover, spherical collar bolts, special metal valve and tag "Important information for light-alloy wheels".
- 4) Parts kit includes: wheel, wheel cover, spherical collar bolts, rubber valve and tag "Important information for wheel mounting".
- 5) Only with plastic wheel cover (part no. 107 400 00 25).

**Notes**

- 14" wheels in production:  
Model 126 through 08/85. Starting 09/85 15" wheels.

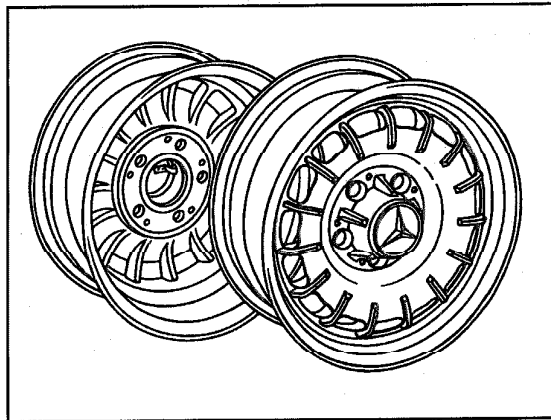

P40-2233-13

- Wheel version:  
Through 09/81 (without trough around valve seat – for special metal valve, arrow).  
Starting 10/81 (with trough around valve seat – for rubber valve, arrow).

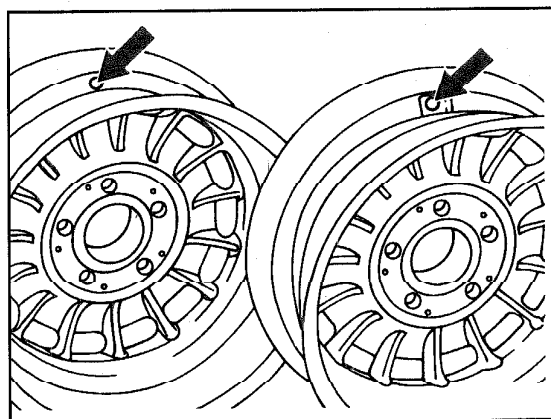

P40-2252-13

## 40-0102 Wheels

### 15" forged light-alloy wheels

Designation	Wheel offset ET mm	Part no.	Model	Remarks
6 1/2 J x 15 H2	21.5	126 400 41 02	126	starting model year 1988.

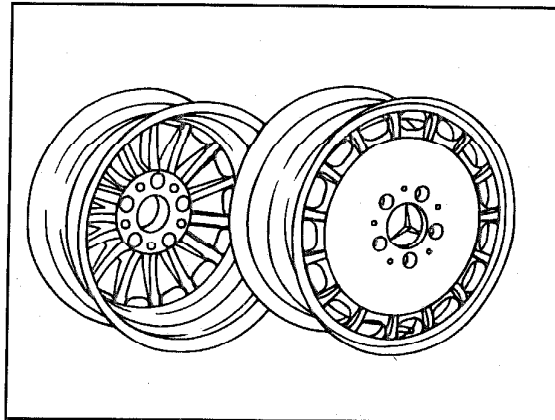

P40-2229-13

Designation	Wheel offset ET mm	Part no.	Model	Remarks
7 J x 15 H2	25	126 400 22 02	126 (through 08/85)	<b>Wheel disk with protruding hub.</b> For subsequent conversion, however for capacity reasons use wheel, part no. 126 400 30 02, (flush wheel disk).

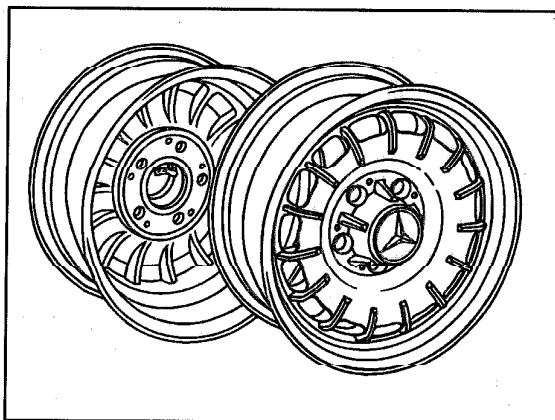

P40-2233-13

## 40-0102 Wheels

Designation	Wheel offset ET mm	Part no.	Model	Remarks
7 J x 15 H2	25	126 400 30 02	126 (starting 09/85)	

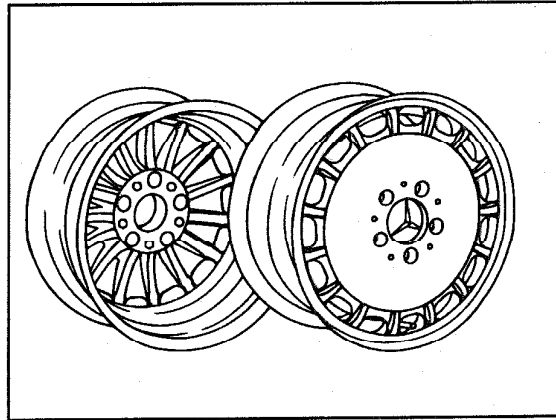

P40-2229-13