

# 35-660 R and R constant velocity joint boots

Preliminary work:  
R and R rear axle shaft (35-620).

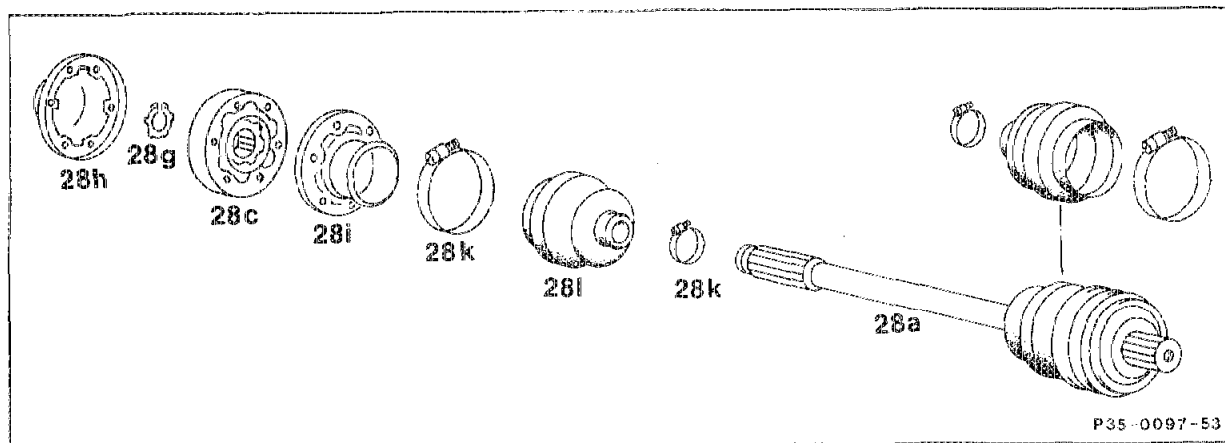

P35-0097-53

P35-0097-53

Hose clamp (28k) . . . . .	remove, attach and replace.
End cover (28h) and rubber boot cap (28i) . . . . .	remove, install, coat sealing surfaces with sealant (steps 3-5).
Retaining ring (28g) . . . . .	remove, install and replace.
Spider joint, complete (28c) . . . . .	press off, press on and clean, removal and installation punch 116 589 15 15 00, clamping jaws 116 589 11 31 00.
Rubber boot (28l) . . . . .	remove, install and replace (step 9).
Inner, outer spider joint . . . . .	check for wear, disassemble and reassemble (steps 10-15).

## Lubricants for constant velocity joints

Model	Lubricant	Quantity in grams per joint		
		inside	outside	
126.02/1	Long life grease	120	120	MB semi-fluid grease is included in each "rubber boot repair kit"
126.03/04	Long life grease	150	120	

Special tools

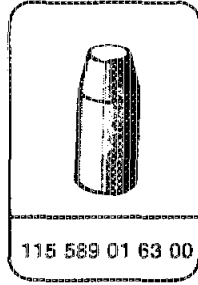
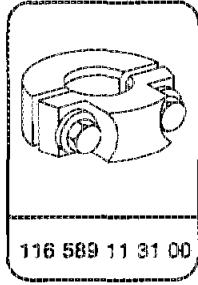
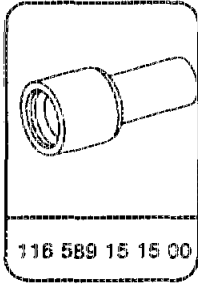

Self-made tool

Half shells for pressing on constant velocity joint

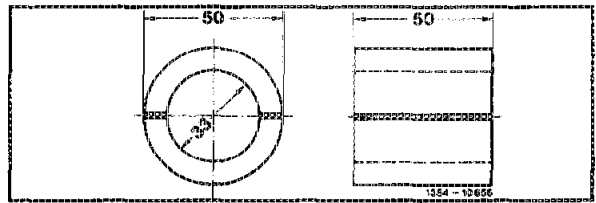

1354-10656

# 35-660 R and R constant velocity joint boots

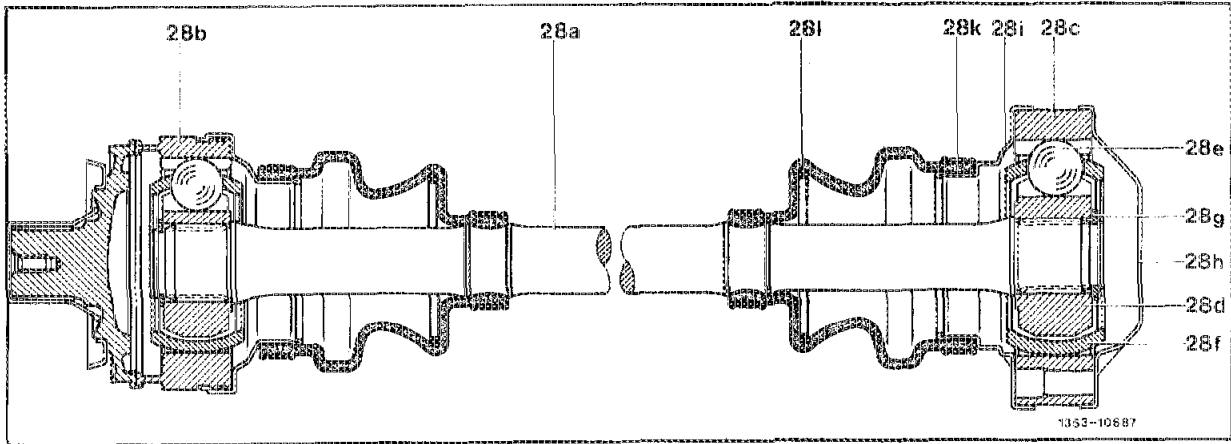

1353-10687

- |     |                    |     |                 |
|-----|--------------------|-----|-----------------|
| 28a | Rear axle shaft    | 28g | Retaining ring  |
| 28b | Outer spider joint | 28h | End cover       |
| 28c | Inner spider joint | 28i | Rubber boot cap |
| 28d | Spider joint hub   | 28k | Hose clamp      |
| 28e | Ball               | 28l | Rubber boot     |
| 28f | Ball cage          |     |                 |

### Note

The rubber boots on the rear axle shaft can only be replaced after disassembling the inner spider joint, because disassembly of the outer spider joint is not possible.

### Disassembly, assembly

- 1 Press hose clamps together with pliers at clamping pipe and remove.

### Installation note

Slide rubber boot on up to bead on rear axle shaft or rubber boot cap and fasten with hose clamp. Assure that hose clamp is properly seated.

If hose clamps with screws are still present, install the two hose clamps on one rubber boot with the screws pointing in the same direction. On the other rubber boot install the clamps so that the screws are turned 180° from the position on the first rubber boot.

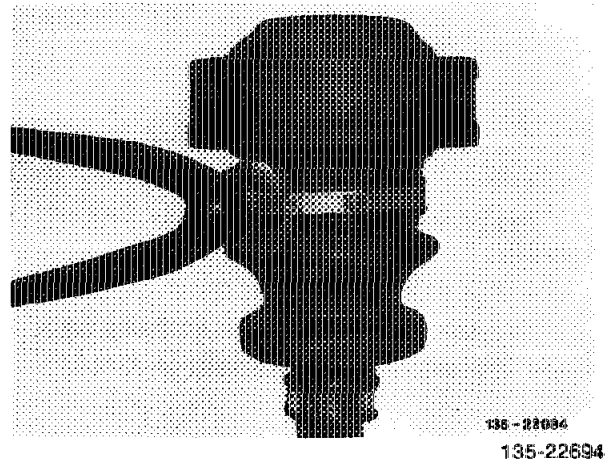

- 2 Press end cover off of spider joint, press on.

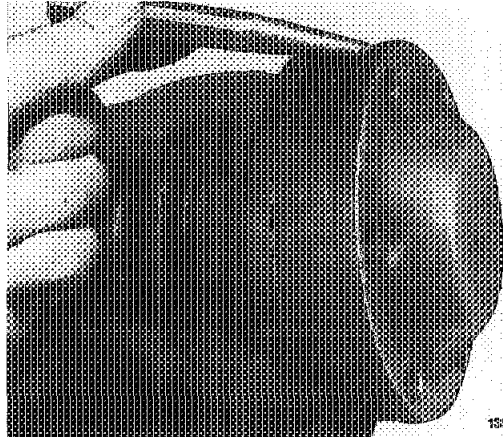

135-22695

135-22695

- 3 Press rubber boot cap off of spider joint, press on.

- 4 Slide rubber boot with rubber boot cap back on rear axle shaft. Clean off grease on joint.

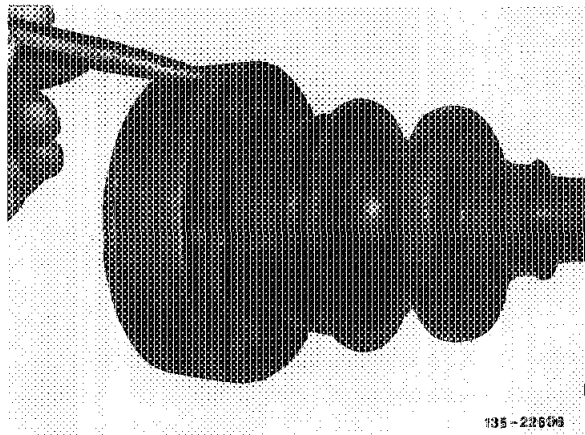

135-22696

135-22696

### Installation note

Coat sealing surfaces on constant velocity joint of end cover and rubber boot cap with sealant (e.g. Curil, Loctite 574 or Hylomar) and install. Install end cover only after packing with grease. Pack constant velocity joint only with prescribed lubricant in specified quantity (see lubricant table for constant velocity joints).

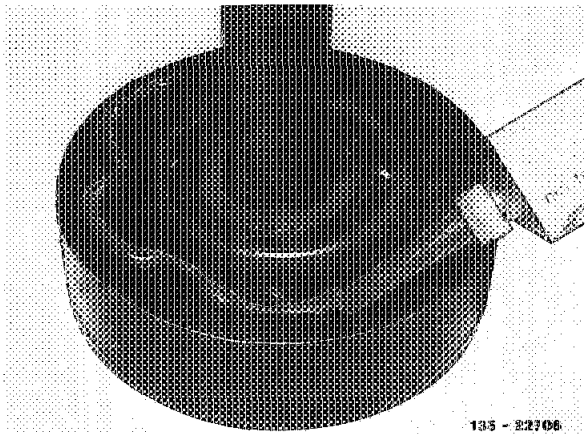

135-22706

135-22706

5 Remove retaining ring, install.

**Installation note**

Replace retaining ring. Assure that the retaining ring is properly positioned in the groove.

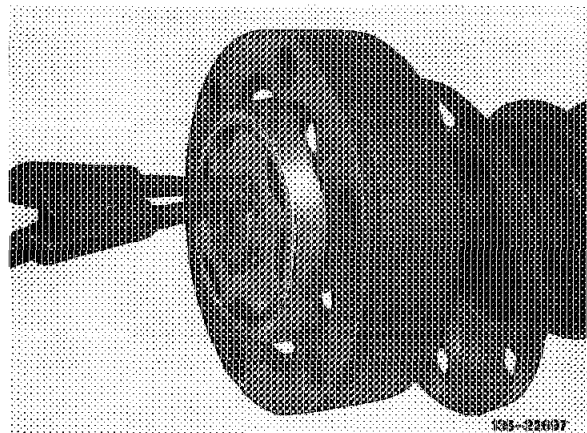

135-22697  
135-22697

6 Press constant velocity joint off of rear axle shaft, press on. Use the two self-made half shells (063a) and the installation and removal punch 116 589 15 15 00 (063).

7 Clean constant velocity joints.

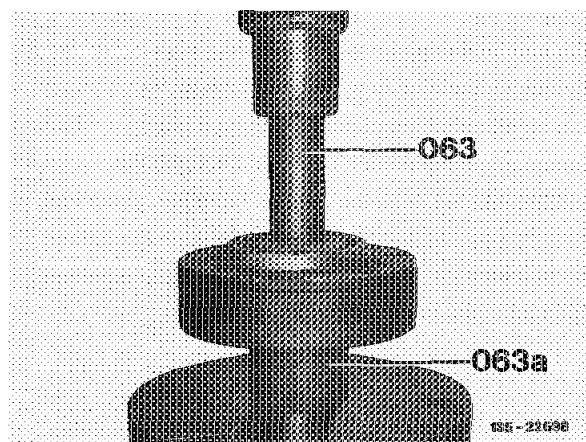

135-22698  
135-22698

**Installation note**

Position clamping jaws on rubber boot collar for rear axle shaft and press on with removal and installation punch up to contact surface on rear axle shaft (arrow). Clamping jaws for rear axle shaft 116 589 11 31 00, installation and removal punch 116 589 15 15 00.

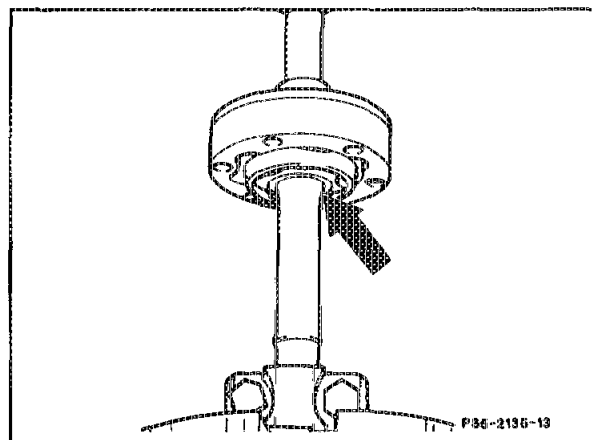

P36-2135-13  
P35-2135-13

8 Pull rubber boot cap and rubber boot off of rear axle shaft.

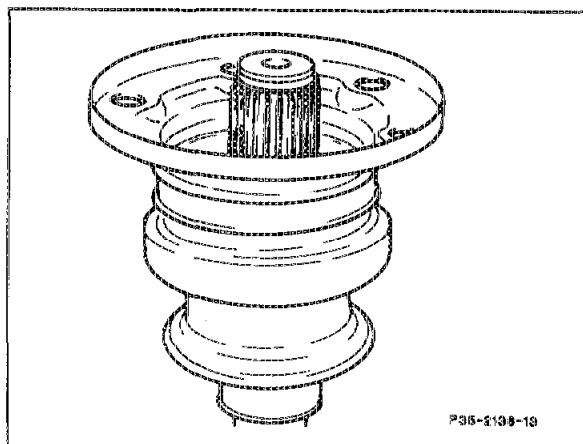

P35-2136-13

### Note

The second rubber boot can now be pulled off if required over the disassembled side of the rear axle shaft after releasing the hose clamps. When pulling off assure that none of the grease packing is lost and that contamination does not get into the inside of the joint. Wipe off grease still present on the inside of the rubber boot and put back into constant velocity joint.

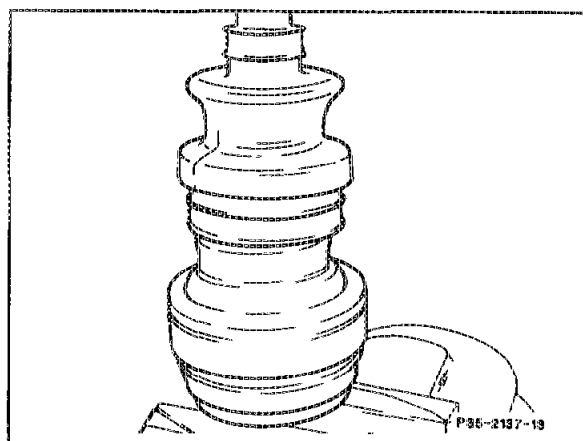

P35-2137-13

### Installation note

Stick assembly sleeve (if still present) onto the toothed shaft profile of the rear axle shaft. Slide rubber collar and rubber collar cap onto rear axle shaft.

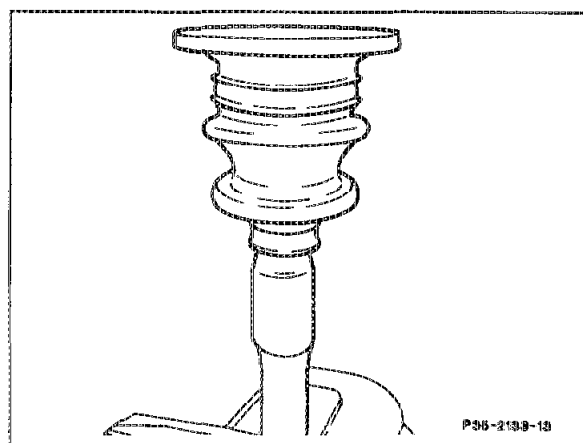

P35-2138-13

**Check constant velocity joint for wear**

9 Disassemble constant velocity joint to check for wear.

10 Before disassembly mark position of spider joint, spider joint hub and ball cage in relation to one another with electric engraving tool or whetstone.

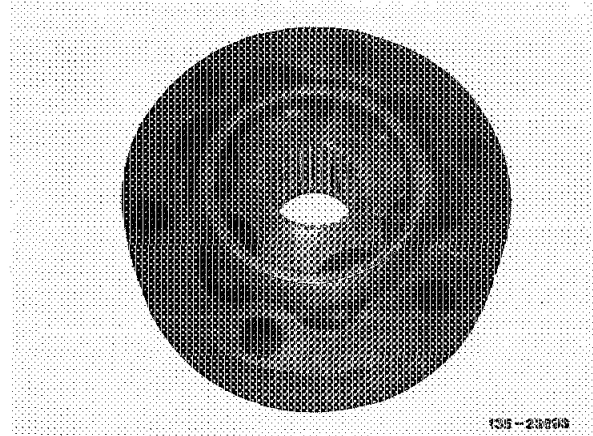

135-22693

135-22693

11 Pivot spider joint hub with ball cage and remove balls individually one after another.

12 Remove spider joint hub with ball cage from spider joint.

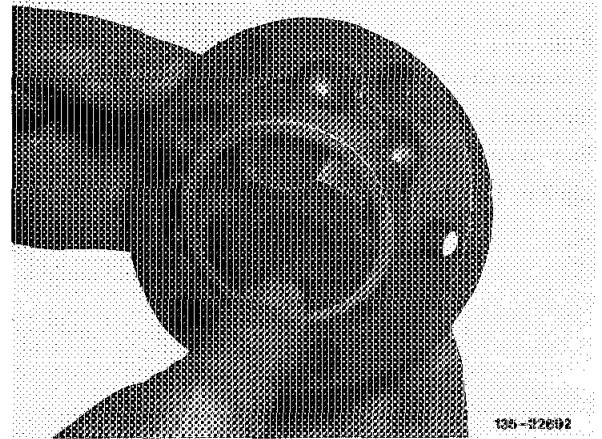

135-22692

135-22692

13 Pivot spider joint hub 90° in relation to ball cage and remove.

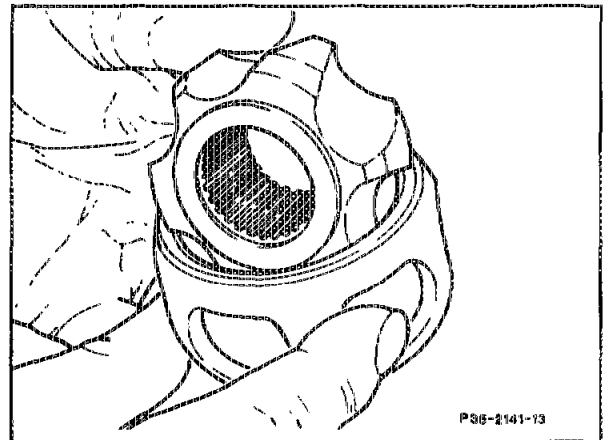

P35-2141-13

P35-2141-13

## 35-660 R and R constant velocity joint boots

---

14 Check ball races of spider joint, spider joint hub, ball cage and balls for pitting and signs of wear (arrows). If these parts show heavy signs of wear, replace complete constant velocity joint. Smooth points or running tracks caused by the balls are not reasons for replacing constant velocity joint.

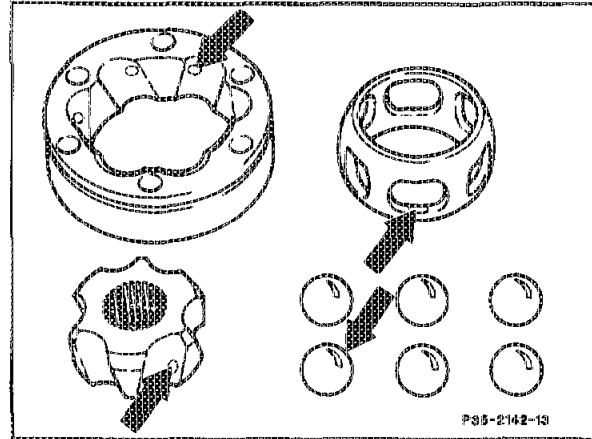

P35-2142-13

P35-2142-13

### Note

A repair kit with all required parts is available for exchanging the rubber boots. If a second rubber boot is required for the same rear axle shaft, use another rubber boot for this purpose.

### Installation note

Position spider joint hub perpendicular to ball cage and insert. Insert one ball while observing marking on spider joint hub and ball cage.

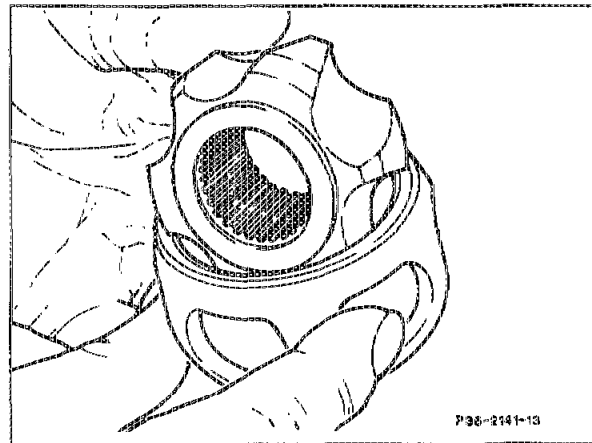

P35-2141-13

P35-2141-13

Insert spider joint hub with ball cage and ball into spider joint while also observing marking (arrow).

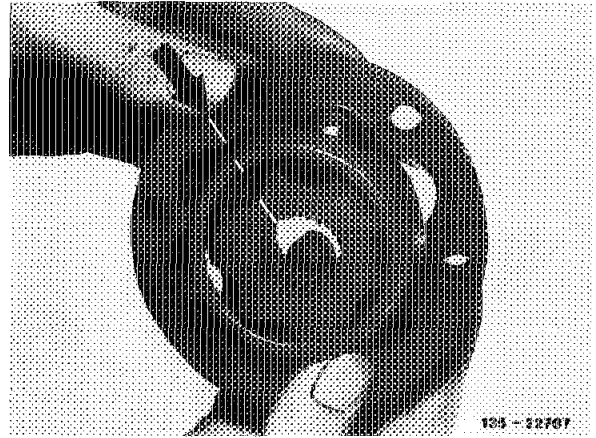

135-22707  
135-22707

Position spider joint hub with ball cage at an angle so that one ball at a time can be inserted.

15 Assemble in opposite order.

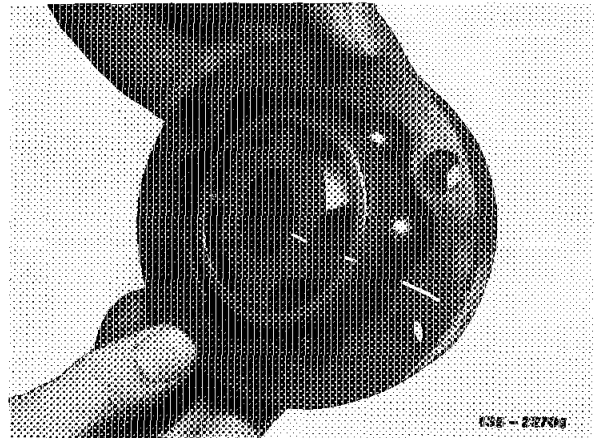

Sixth ball inserted

135-22706  
135-22706