

## 35-410 Inspection of rear axle assembly

### Adjusting dimensions for inspection

		Model 107.02, 114, 115	1025 ± 0.3 mm
Distance "d" of control mounts for front bearing of rear axle carrier		Model 107.04	820 ± 0.3 mm
		Model 116	1214 ± 0.3 mm
		Model 123	1190 ± 0.3 mm
		Model 126	1192 ± 0.7 mm
		Model 107.02, 114, 115	303 ± 0.5 mm
To upper edge of rear axle carrier center at front end		Model 116, 126	299 ± 0.5 mm
		Model 123	314 ± 0.5 mm
		Model 107.04	361 ± 0.5 mm
Distance "e" from measuring table	To lower edge of rear axle carrier center at rear end of rear axle without drive members <sup>1)</sup>	Model 107.04	361 ± 0.5 mm
	To center of drive pinion pin of rear axle with drive members	Model 107.042	269 ± 0.5 mm
		Model 107.043/044/045/046	255 ± 0.5 mm
Distance "f" from measuring table to rear axle shaft flange at upper edge for wheel fit		Model 107.02, 114, 115	293.5 ± 0.5 mm
		Model 107.04	318 ± 0.5 mm
		Model 116, 126	282.5 ± 0.5 mm
		Model 123	287.5 ± 0.5 mm

<sup>1)</sup> The measuring point refers to height of 12.5 mm bore.

## 35-410 Inspection of rear axle assembly

### Test values

Rear axle shaft flange	Lateral runout	0 to 0.12 mm	
Camber (+) or (-)	Model 107.02 114, 115 1st version 123 1st version	- 0° 45' ± 30'	
	Model 107.042 1st version 107.043/044	- 1° 20' ± 30'	
	Model 107.042 2nd version 107.045/046	- 1° 30' ± 30'	
	Model 116, 126 107.02 2nd version 123 2nd version	- 1° ± 30'	
Toe-in (+) or toe-out (-) (measuring points for toe-in per wheel (VSR1), reference points for toe-in total (VSG1) <sup>1</sup> )	Model 107.043/044, 114, 115, 116 107.02/042 and 123 1st version	per wheel	+ 0.5 + 1.0 - 0.5 mm
		total	+ 1.0 + 2.0 - 1.0 mm
	Model 107.045/046 107.02/042 and 123 2nd version <sup>2</sup> )	per wheel	+ 1.5 + 0.5 - 1.0 mm
	126	total	+ 3.0 + 1.0 - 2.0 mm

1) Measurement difference between front and rear in reference to 14" rim diameter (measuring points for toe-in per wheel (VSR1) and/or reference points for total toe-in (VSG1) at a distance of 185 mm from wheel center). The values correspond to those toe-in values resulting during running gear measurement.

The doubled measuring values resulting from the additional control measurement of the total toe-in (VSG2) (measuring points 370 mm from wheel center) must be halved for comparison with the total toe-in values (VSG1).

When comparing the toe-in measurement values obtained during running gear measurement with an axle measuring device in curb condition and measurement on the test bench in design position it must be noted that the values obtained during curb condition measurement can be 0.5 mm greater per wheel due to the higher semi-trailing arm position.

2) Identification characteristics on rear axle carrier 2nd version:

On model 123 additional bore of 10 mm dia. on the righthand, inner bearing bracket for connection of semitrailer.

On model 107.042 starting March 1980 and model 107.045/046 starting begin of production provided with spring bracket at outside with a recess.

### Comparison table for toe-in millimeters/degrees

Toe-in (VSR1 or VSG1 when checking rear axle on measuring table <sup>1</sup> )	corresponds to toe-in on axle measuring instrument	Toe-in (VSR1 or VSG1 when checking rear axle on measuring table <sup>1</sup> )	corresponds to toe-in on axle measuring instrument
0.5 mm	0° 4' 30"	5.5 mm	0° 49' 30"
1.0 mm	0° 9'	6.0 mm	0° 54'
1.5 mm	0° 13' 30"	6.5 mm	0° 58' 30"
2.0 mm	0° 18'	7.0 mm	1° 03'
2.5 mm	0° 22' 30"	7.5 mm	1° 07' 30"
3.0 mm	0° 27'	8.0 mm	1° 12'
3.5 mm	0° 31' 30"	8.5 mm	1° 16' 30"
4.0 mm	0° 36'	9.0 mm	1° 21'
4.5 mm	0° 40' 30"	9.5 mm	1° 25' 30"
5.0 mm	0° 45'	10.0 mm	1° 30'

1) Measuring values with reference to 14" rim dia. (distance 185 mm from wheel center).

## 35-410 Inspection of rear axle assembly

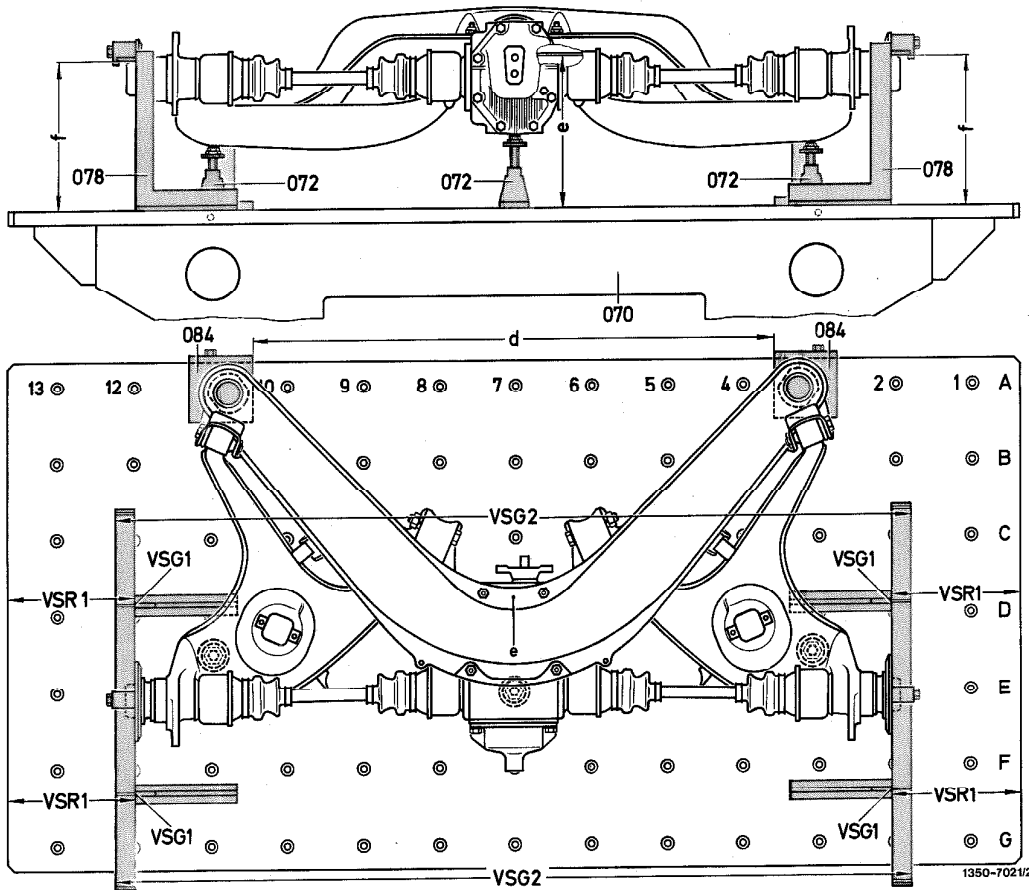

- d Adjusting dimension of control mounts for front bearings
- e Height adjusting dimension for rear axle carrier center
- f Height adjusting dimension to rear axle shaft flange on upper edge for wheel fit
- VSR1 Measuring points for toe-in per wheel (with reference to 14" rim dia at a distance of 185 mm from wheel center)
- VSG1 Reference points for toe-in total (with reference to 14" rim dia at a distance of 185 mm from wheel center)
- VSG2 Measuring points for additional control measurement of toe-in total (with reference to double 14" rim dia at a distance of 370 mm from wheel center)

- 070 Measuring table
- 072 Jack
- 078 Try square
- 084 Control mounts

### Semi-trailing arm position in design position

(For comparison, inspection on measuring table and chassis measurement)

Model	Diagonal swing axle	Diagonal swing axle with starting torque compensation
107.022 to August 1980	+ 16 mm	108 mm
107.023, 107.024, 107.026		
107.022 starting September 1980	+ 19 mm	—
107.025 <sup>1)</sup>	+ 14 mm	—
107.042 up to February 1980	+ 6 mm	—
107.043, 044, 045, 046	+ 6 mm	97 mm
107.042 starting March 1980	+ 11 mm	—
107.045 (USA)		
114, 115	+ 16 mm	—
116	+ 12 mm	105 mm
123	+ 21 mm	—
126	+ 12 mm	106 mm

1) (USA) + 19 mm.

# 35-410 Inspection of rear axle assembly

## Data Sheet for Rear Axle Wheel Location

Checking on Test Bench of Vehicles Involved in and Suspected of being Involved in an Accident



Branch/Agency

Customer

Measurement carried out: Date/Name Day Rep.-Order No.

Registration Number Initial Registration Model Chassis No. Speedometer reading: km/mi.

Received from Received time Received by Engine No. Non-binding delivery date

Testing the diagonal swing axle Models 107, 114, 115, 116, 123, 126			Measurement data		Remarks	
			prior to axle repair	following axle repair		
Wheel suspension, complete	Rear axle shaft flange Lateral runout	mm	left			
			right			
	Camber (+) or (-)	degrees	left			
			right			
	Toe-in (+) or toe-out (-) (measuring points for toe-in per wheel (VSR1), reference points for total toe-in (VSG1) <sup>1) 2) 3)</sup> )	mm	left			
			right			
total						
Semitrailing arm	Distance (b) between bearings measured across inner side	mm	left			
			right			
	Camber (+) or (-)	degrees	left			
			right			
	Toe-in (+) or toe-out (-) (measuring points for toe-in per wheel (VSR1) <sup>1)</sup> )	mm	left			
			right			
Rear axle carrier	Distance (c) between front mounts	mm				
	Camber deviation (STA) and toe-in deviation (SPA) on the outer bearing brackets for hinging the semitrailing arms <sup>4)</sup> )	mm	left	STA		
				SPA		
			right	STA		
SPA						

<sup>1)</sup> Measurement difference between front and rear in reference to 14" rim diameter (measuring points for toe-in per wheel (VSR1) and/or reference points for total toe-in (VSG1) at a distance of 165 mm from wheel center). The values correspond to those toe-in values resulting during running gear measurement.

<sup>2)</sup> The doubled measuring values resulting from the additional control measurement of the total toe-in (VSG2) (measuring points 370 mm from wheel center) must be halved for comparison with the total toe-in values (VSG1).

<sup>3)</sup> When comparing the toe-in measurement values obtained during running gear measurement with an axle measuring device in curb condition and measurement on the test bench in design position it must be noted that the values obtained during curb condition measurement can be 0.5 mm greater per wheel due to the higher semitrailing arm position.

<sup>4)</sup> Measurement via light slit between the check support pin and the bore in the bearing bracket of the rear axle carrier. Even circumferential gap of light in the bore = 0 mm deviation. Pin contact in the bore = 1 mm deviation.

## Testing Wheel Suspension, Complete

- d Adjustment dimension of the check supports for the front mounts of the rear axle carrier
  - e Height adjusting dimension to center of rear axle carrier
  - f Height adjusting dimension for rear axle shaft flange measured at upper edge of wheel centering collar
- VSR1 Measuring points for toe-in per wheel (in reference to 14" rim diameter at a distance of 185 mm from wheel center).
- VSG1 Reference points for total toe-in (in reference to 14" rim diameter at a distance of 185 mm from wheel center).
- VSG2 Measuring points for additional control measurement of the total toe-in (in reference to the doubled 14" rim diameter at a distance of 370 mm from wheel center).

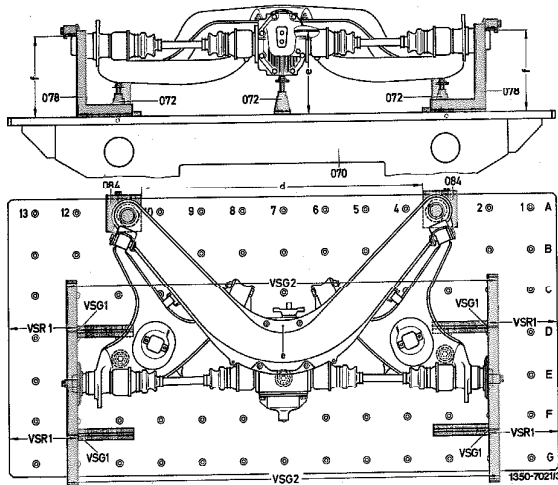

## Testing Semitrailing Arm

- a Height adjusting dimension for rear axle shaft flange measured at upper edge of wheel centering collar
  - b Distance between bearings measured across inner side (control dimension)
- VSR1 Measuring points for toe-in per wheel (in reference to 14" rim diameter at a distance of 185 mm from wheel center).

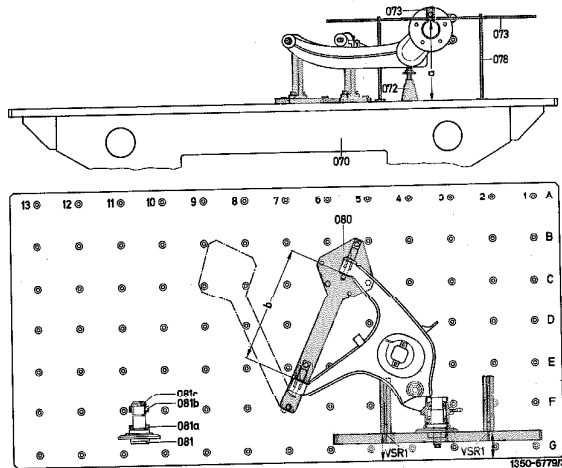

## Testing Rear Axle Carrier

- c Distance between front mounts (control dimension)
- STA Measuring points for camber deviation
- SPA Measuring points for toe-in deviation

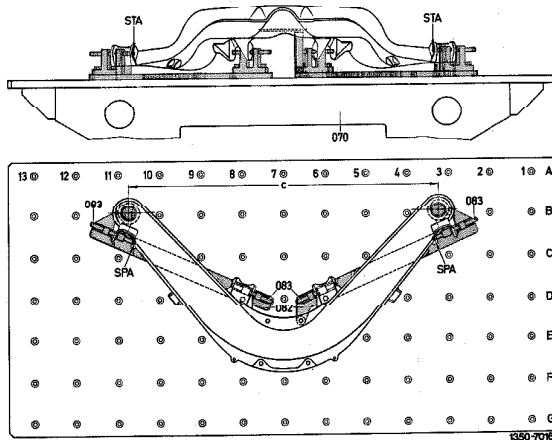

## 35-410 Inspection of rear axle assembly

---

### Required equipment

---

Measuring table with coordinate  
bore holes 13 mm dia F7,  
spacing 150 mm

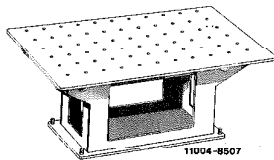

BE 03600 1522  
E 0145

---

### Special tools

---

Control mounts for  
complete directional  
stability system

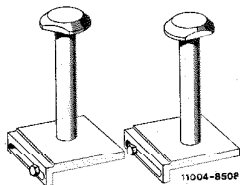

116 589 13 23 00

---

Intermediate rings for control mounts  
for complete wheel location model 126

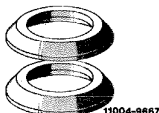

126 589 00 63 00

---

Jack, adjustable from 100 to 160 mm  
(required 3 each)



116 589 08 31 00

---

Straightedge (750 mm long)  
with holder  
(required 2 each)

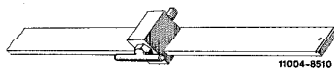

116 589 12 31 00

---

Magnetic holder for dial gauge

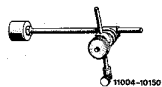

363 589 02 21 00

---

Measuring flange for semi-trailing arm  
and coupled semi-trailing arm without  
wheel bearing

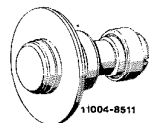

116 589 31 21 00

---

## 35-410 Inspection of rear axle assembly

### Self-made tool

Measuring base for  
magnetic holder  
Material: steel

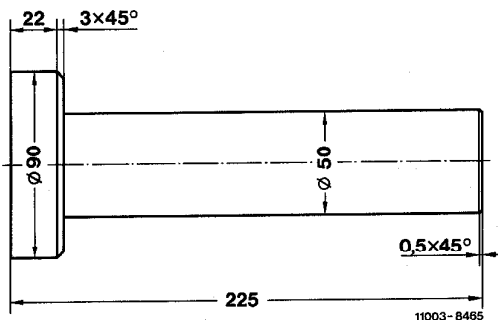

### Conventional tools

Dial gauge A 1 DIN 878	e.g. made by Mahr D-7300 Esslingen Order no. 810
Extension 50 mm for dial gauge	e.g. made Mahr D-7300 Esslingen Order no. 902
Try square 300 x 200 mm (required 2 each)	e.g. made by Stiefelmayer D-7300 Esslingen Order no. 151 AR
Height measuring and tracing tool size III	e.g. made by Stiefelmayer D-7300 Esslingen Order no. 5 V
Bell-type mount for angle measuring tool	e.g. made by Beissbarth D-8000 Munich Order no. P1/96
Angle measuring tool	e.g. made by Beissbarth D-8000 Munich Order no. P 10/05

### Notes

Measuring of complete directional stability system will be of advantage if chassis measurements cannot be made on a vehicle following an accident with e.g. heavy front axle or front end damage or also if chassis measurements provide no clear-cut diagnosis of rear axle. If such measurements are within the specified tolerances, additional checkups of the individual semi-trailing arms and rear axle carriers are not required.

A checkup of the complete directional stability system is not required if a visual checkup is already showing deformations on rear axle carrier or on a semi-trailing arm. In such a case, check the individual components whenever required.

Measuring of complete directional stability system is principally the same for all axles of the respective models; only the different adjusting dimensions must be taken into account when making preparations for measuring.

For measuring the directional stability system and its various components a measuring table of 2000 x 1000 mm will be required. The measuring table has coordinate bore holes of 13 mm dia F7 spaced 150 mm apart for locating the control mounts. The coordinate bore holes are identified in longitudinal direction with the numbers 1 to 13 and in transverse direction with the letters A to G.

## 35-410 Inspection of rear axle assembly

The principle of checking the complete directional stability system and the semi-trailing arms is about the same as for chassis measurements. The optical rectangular established around the vehicle for chassis measurements is replaced by the measuring table for the mechanical measurement of the directional stability system and its components.

The measuring values before and following axle reconditioning must be recorded in "Data sheet for directional stability of rear axle".

For checking on measuring table, the components of the directional stability system are located on measuring table in such a manner that the position of the semi-trailing arms corresponds to the design position, i.e. to a medium vehicle load. When comparing the measuring values between the checkup on the measuring table and the chassis measurements with vehicle ready for driving, refer to table "Semi-trailing arm position in design position".

The checkup of the complete directional stability system of rear axle comprises:

- a) Checking rear axle shaft flanges for lateral runout
- b) Rear axle camber
- c) Toe-in per wheel (VSR1), total toe-in (VSG 1 and VSG 2)

On rear axle carrier for model 123, starting April 1977, a change has been made on bearing brackets for connection of semi-trailing arms. Compared with the 1st version, the camber of the complete directional stability system has been changed in minus direction by approx.  $0^{\circ} 15'$  and the toe-in in plus direction by approx. 1.0 mm per wheel.

Identification starting January 1978 for rear axle carrier of 2nd version:

Additional bore of 10 mm dia at right-hand, inner bearing for connection of semi-trailing arm (arrow).

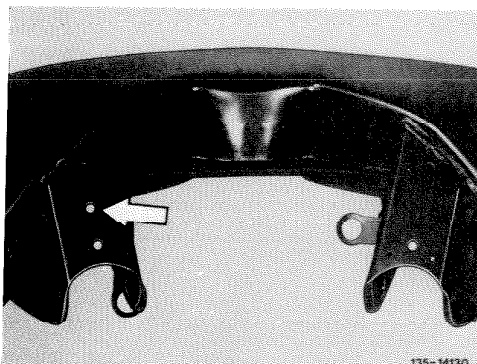

### Series production of rear axle carrier 2nd version on model 123

Model	—	Starting chassis end no.	Model	Starting chassis end no.	
Sedans	123.020	038 541	Sedans long	123.028	022 886
	123.023	048 372		123.125	033 764
	123.026	022 886		123.132	042 755
	123.030	016 635	T sedans	123.083	000 001
	123.033	024 625		123.086	000 001
	123.120	053 863		123.093	000 001
	123.123	033 764		123.183	000 001
	123.126	022 239		123.190	000 001
	123.130	043 755			
	Coupes	123.043		000 001	Special vehicles (bodies made by others)
123.050		000 001	123.003	022 886	
123.053		000 001	123.007	000 001	
123.150		000 001	123.102	033 764	
			123.103	033 764	
		123.105	043 755		

## 35-410 Inspection of rear axle assembly

On rear axle carrier for model 107.022 starting September 1980 and 107.042 starting March 1980, the bearing brackets for swivelling semi-trailing arm has been modified. As a result, compared with 1st version, the complete wheel location resulted in a change of toe-in in plus direction by approx. 1.0 mm per wheel.

Identifying characteristics starting March or September 1980 for rear axle carrier of 2nd version:

Additional bore of 10 mm dia. on righthand, inner bearing bracket for swivelling semi-trailing arm on model 107.022 and on model 107.042 provided with a recess on both resilient stops on outer side (arrow).

Beginn of series production of rear axle carrier 2nd version on model 107.022 and 107.042, no chassis end number has been recorded.

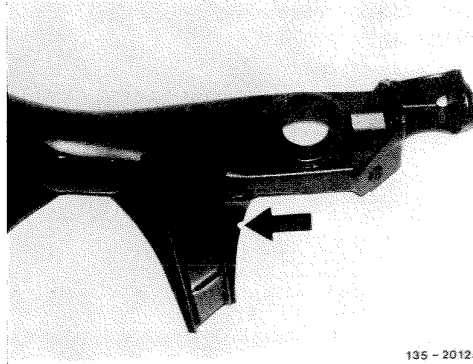

135 - 20125

### Preparation for checkup

- 1 Remove brake caliper and brake disc (42-228).
- 2 Force both rubber mounts of front rear axle bearings out of rear axle carrier (35-040).

- 3 Set distance "d" of control mounts on measuring table and attach control mounts.

### Adjusting dimensions

Model 107.02, 114, 115	$1025 \pm 0.3$ mm
Model 107.04	$820 \pm 0.3$ mm
Model 116	$1214 \pm 0.3$ mm
Model 123	$1190 \pm 0.3$ mm
Model 126	$1192 \pm 0.7$ mm

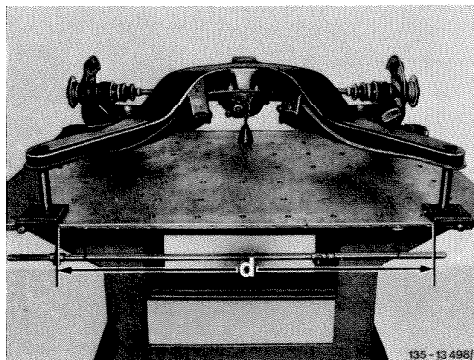

135 - 13 498/1

## 35-410 Inspection of rear axle assembly

4 On model 126, include additional intermediate rings on control mounts (arrow).

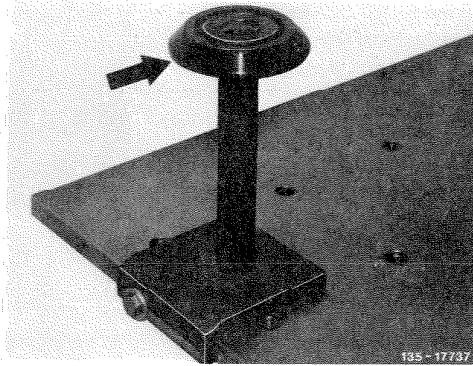

5 Place directional stability assembly on control mounts and support rear axle center housing or rear axle carrier center as well as both semi-trailing arms by means of jacks.

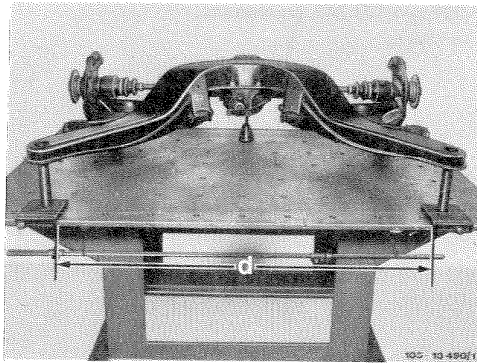

6 Distance "e" on models 107.02, 114, 115, 116, 123 and 126 on rear axle with or without drive members, adjust rear axle carrier at front end (arrow) by means of a height measuring instrument from measuring table to upper edge of rear axle carrier center. For this purpose, change height of jack accordingly.



### Adjusting dimensions

Model 107.02, 114, 115	$303 \pm 0.5$ mm
Model 116, 126	$299 \pm 0.5$ mm
Model 123	$314 \pm 0.5$ mm

**Note:** The adjusting dimension refers to surface of upper shell of rear axle carrier. Pay attention to weld seam in measuring range, if applicable.

7 Adjust distance "e" on model 107.04 on one rear axle **with** drive members by means of a precision measuring tape or height measuring tool from measuring table to center of pin on drive pinion. For this purpose, change height of jack accordingly.

**Adjusting dimensions**

Model 107.042	$269 \pm 0.5$ mm
Model 107.043/044 107.045/046	$255 \pm 0.5$ mm

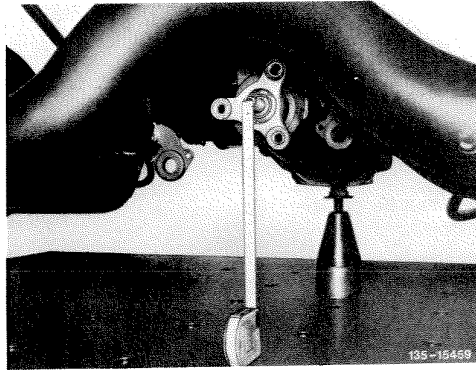

8 Adjust distance "e" on model 107.04 on one rear axle **without** drive members with a height measuring tool from measuring table to bottom edge of rear axle carrier at rear end in center to height of 12.5 mm bore (arrow). For this purpose, change height of jack accordingly.

**Adjusting dimension**

Model 107.04	$361 \pm 0.5$ mm
--------------	------------------

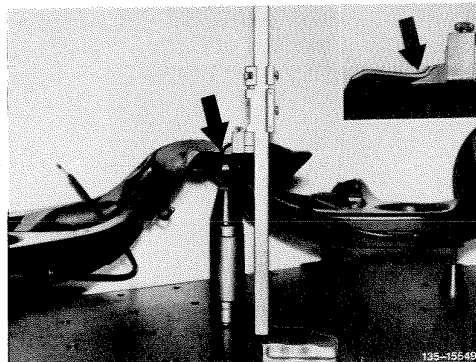

9 Adjust distance "f" with a height measuring tool from measuring table of upper edge of wheel fit on rear axle shaft flange left and right. For this purpose, change height of jack accordingly.

**Adjusting dimensions**

Model 107.02, 114, 115	$293.5 \pm 0.5$ mm
Model 107.04	$318 \pm 0.5$ mm
Model 116, 126	$282.5 \pm 0.5$ mm
Model 123	$287.5 \pm 0.5$ mm

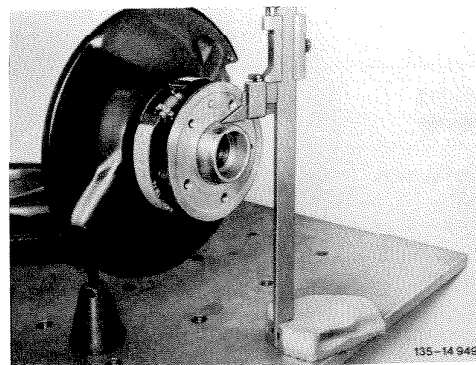

**Checkup**

**Rear axle shaft flange**

10 Check rear axle shaft flange at left and right for lateral runout. For this purpose, use dial gauge with magnetic holder and self-made measuring base

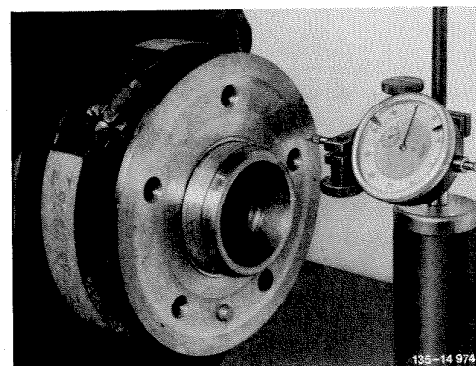

## 35-410 Inspection of rear axle assembly

### Attention!

If lateral runout of rear axle shaft flange is above permissible tolerance range, insert measuring flange for additional checkups.

Mount measuring flange:

- Remove rear axle shaft flange (35-130).
- Knock-out outer race of inner tapered roller bearing, pull off outer race of outer tapered roller bearing by means of pertinent device.
- Introduce measuring flange with outer spacing ring. Mount inner spacing ring with small diameter facing flange end and slightly tighten slot nut.

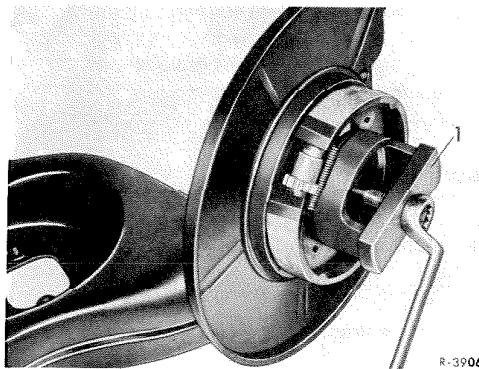

### Attention!

Measuring flange should be seated in wheel carrier of semi-trailing arm without play.

- 75 Semi-trailing arm
- 081 Measuring flange
- 081a Outer spacer ring (pressed-on)
- 081b Inner spacer ring
- 081c Slot nut

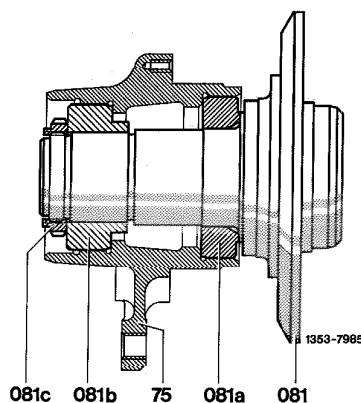

### Rear wheel camber

11 Measure rear wheel camber left and right, using angle measuring instrument with bell-type mount for this purpose.

#### Test values

Model 107.02, 114, 115 123 1st version	$-0^{\circ} 45' \pm 30'$
Model 107.042 1st version 107.043/044	$-1^{\circ} 20' \pm 30'$
Model 107.042 2nd version 107.045/046	$-1^{\circ} 30' \pm 30'$
Model 116, 120 123 2nd version	$-1^{\circ} \pm 30'$

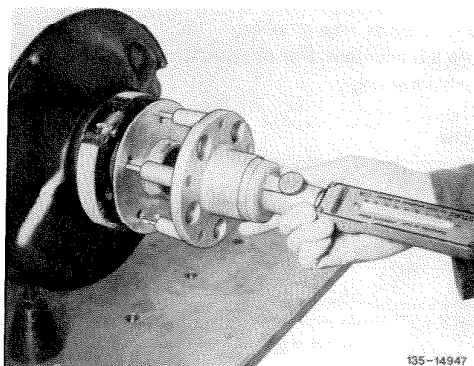

#### Note:

- Steel plate semi-trailing arm

If the camber is higher than the permissible tolerance range, the fault may be a distortion of the semi-trailing arm itself or of the bearing brackets on rear axle carrier. However, experience has shown that on steel plate semi-trailing arms a distortion is mainly characterised by a misalignment (deviation) in direction of track.

- Light alloy coupled semi-trailing arm

If the camber is higher than the permissible tolerance range, the fault may be a distortion of the separate wheel carrier or of the bearing brackets of rear axle carrier, or a distortion of both components. The cast light alloy coupled semi-trailing arm itself will not yield both in direction of camber and track. If the wheel carrier is only slightly distorted in direction of camber, continued use of semi-trailing arm in combination with a new wheel carrier is permitted. In the event of major distortions of wheel carrier (camber misalignment more than  $1^{\circ}$ ), the semi-trailing arm should be replaced for safety reasons to eliminate any risk of incipient cracks.

## 35-410 Inspection of rear axle assembly

### Toe-in per wheel (VSR 1) and total toe-in (VSG1)

**Note:** A straightedge on rear axle shaft flange serves for measuring toe-in. Measuring points for toe-in per wheel (VSR1) are the inside marks applied 185 mm from wheel center with reference to 14" rim dia. The measuring values thereby correspond to values of chassis measurements at respective position of semi-trailing arms (also refer to comparison table for toe-in values in millimeters and degrees). The outer marks on straightedge at a distance of 370 mm from wheel center are serving for an additional reference measurement of total toe-in (VSG2). For technical reasons the double toe-in is measured, so that the value **must be halved** for comparison with toe-in values (VSG1) with reference to 14" rim dia.

12 Attach straightedge with holder to rear axle shaft flange while paying attention to the two markings for wheel center. Set straightedge into horizontal position by measuring and compensating vertical distance of straightedge in relation to measuring table both at front and rear.

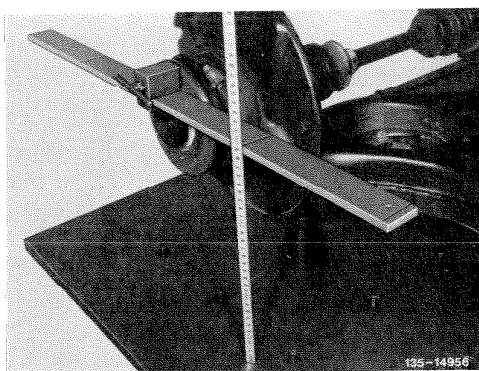

13 Position try square at front against inner mark of straightedge, using a second try square for this purpose.

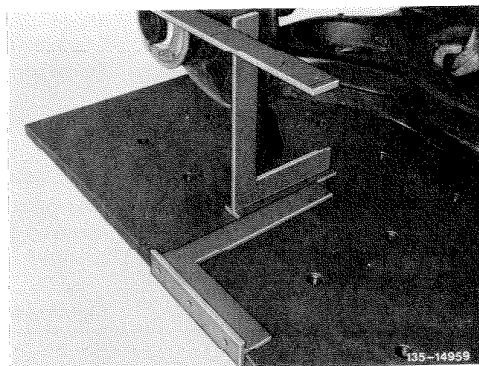

14 Measure front distance from edge of measuring table to try square or to straightedge by means of depth gauge and write down value.



## 35-410 Inspection of rear axle assembly

15 Place try square at the rear against inner mark of straightedge using a second try square for this purpose.

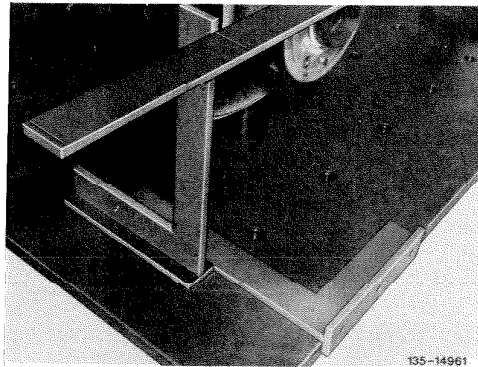

16 Measure rear distance from edge of measuring table to try square or to straightedge with depth gauge and write down value.

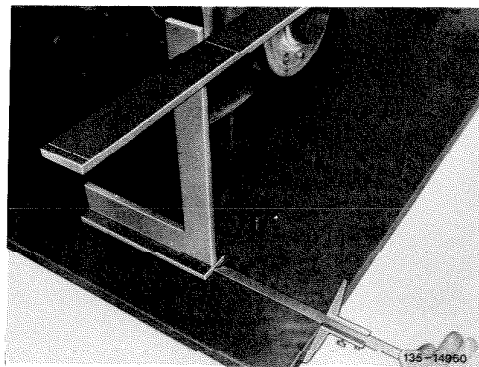

17 To find toe-in per wheel (VSR1) determine difference between values measured at the front and rear and enter into data sheet. The sum of measurements at left and right provide the total toe-in (VSG1).

### Attention!

Make sure whether there is toe-in (+) in toe-out (-)!

Test values	Toe-in per wheel (VSR1)
Model 114, 115, 116 107, 123 1st version	+ 0,5 + 1,0 - 0,5 mm
Model 107, 123 2nd version 126	+ 1,5 ± 1,0 mm

Test values	Total toe-in (VSG1)
Model 114, 115, 116 107, 123 1st version	+ 1,0 + 2,0 - 1,0 mm
Model 107, 123 2nd version 126	+ 3,0 ± 1,5 mm

**Example: Model 123 2nd version**  
**Toe-in per wheel (VSR1)**

Left-hand wheel:

Front value	=	162.5 mm
Rear value	=	161.0 mm
results in difference or toe-in	=	+ 1.5 mm

Right-hand wheel:

Front value	=	157.0 mm
Rear value	=	150.5 mm
results in difference or toe-in	=	+ 6.5 mm

**Total toe-in (VSG1)**

Toe-in left-hand wheel	=	+ 1.5 mm
Toe-in right-hand wheel	=	+ 6.5 mm
results in		
Total toe-in	=	+ 8.0 mm

## 35-410 Inspection of rear axle assembly

---

**Note:** The example shows a toe-in for lefthand wheel which is in order, while the righthand wheel is subject to a distortion of semi-trailing arm or rear axle carrier, which resulted in a larger toe-in. For additional evaluation, the righthand semi-trailing arm and the rear axle carrier must be additionally checked. Experience has shown that with larger deviations of toe-in (more than 6 mm per wheel), both the steel plate semi-trailing arm as well as the respective bearing brackets of the rear axle carrier are no longer in order.

On the other hand, with a cast light alloy coupled semi-trailing arm, which is not yielding both in direction of camber and track, a misalignment (deviation) of toe-in is mainly having an influence on bearing brackets of rear axle carrier. A distortion of wheel carrier may also be included (refer to section "Rear wheel camber", as well as to 35-420 "Checking semi-trailing arms").

Since a light alloy coupled semi-trailing arm is subject to a risk of incipient cracks, replace for safety reasons, if

- a) the wheel carrier is distorted in direction of track. Check during individual checkup of semi-trailing arm (35-420).
- b) the rear axle carrier shows major distortions on bearing brackets (deviations in direction of track or camber more than 5 mm). Check during individual checkup of rear axle carrier (35-430).

### Total-toe-in (VSG2) (Additional reference measurement)

---

18 Measure at outer marks of straightedge the distance at the rear from left to right by means of a precision measuring tape and write down value.

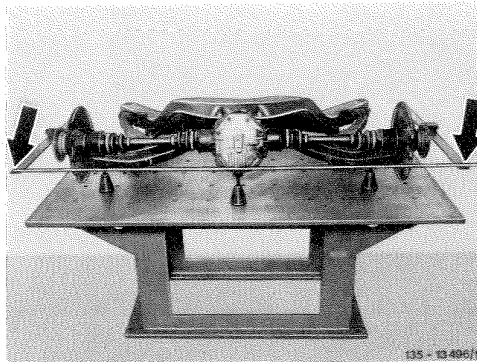

19 Measure distance at front from left to right at outer marks of straightedges and also write down value.

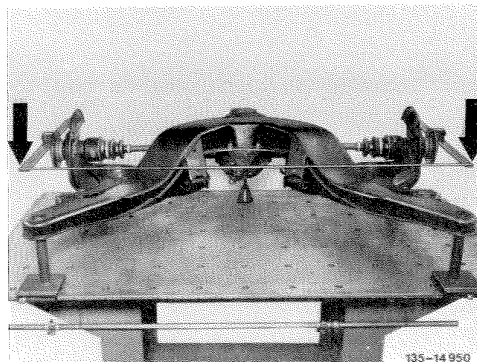

## 35-410 Inspection of rear axle assembly

---

20 To determine total toe-in (VSG2) determine difference between values measured at front and rear, making sure whether it is toe-in (+) or toe-out (-).

Half the measuring value is the value of the total toe-in (VSG1) with reference to rim dia.

**Example:**

Rear value	= 1587 mm
Front value	= 1571 mm
results in difference	
or total toe-in (VSG2)	= + 16 mm
corresponding to	
total toe-in (VSG1)	= + 8 mm