

35-360 R and R caliper carrier and hub, adjust wheel bearing

Diagonal swing axle with starting torque compensation

Wheel bearing

End play of rear axle shaft flange	0.04-0.06
------------------------------------	-----------

Rear axle shaft flange

Permissible vertical runout on concentric alignment in installed condition	0.12
--	------

Permissible lateral runout in installed condition	0.12
---	------

Thickness of flange	9.5-10.0
---------------------	----------

Permissible vertical runout on bearing seats and on surfaces for radial sealing rings	0.03
---	------

Permissible vertical runout on concentric alignment	0.02
---	------

Fit (diameter) for brake disc	67.00
	66.97

		46.028
	outside	46.017

Dia. of bearing seats		41.013
	inside	41.002

Dia of running surface for outside radial sealing ring		72.00
		71.81

	lefthand flange	righthand twist
Threads on running surface for outer radial sealing ring	righthand flange	lefthand twist
	Length of twist (threads) on circumference of running surface	20

Width of spacing sleeve	11.8-12.0
-------------------------	-----------

Lubricants

Lubricant for rear wheel bearing	Multi-purpose grease refer to specifications for service products page 267
----------------------------------	---







Quantity each side	50 g
--------------------	------

Tightening torque	Nm
-------------------	----

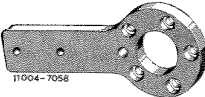
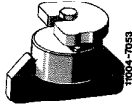
Hex bolt for attaching link to caliper carrier	25
--	----

35-360 R and R caliper carrier and hub, adjust wheel bearing

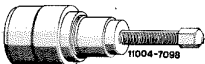
Special tools

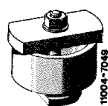
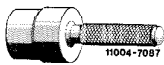
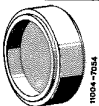
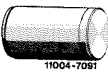
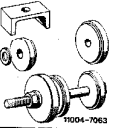
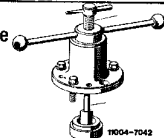
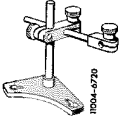
Assembly plate for rear axle shaft flange		136 589 05 31 00
Clamp for coupled semi-trailing arm		116 589 03 31 00
Socket for slot nut on rear axle shaft flange		115 589 02 07 00
Remover and installer for radial ball bearing of caliper carrier		116 589 10 43 00
Connection 3/4" square head to 1/2" square socket		100 589 02 59 00
Thrust piece for puller 001 589 36 33 00		000 589 03 34 00
Puller for tapered roller bearing inner races (basic tool)		001 589 36 33 00
Collet for puller 001 589 36 33 00 for tapered roller bearing inner race		000 589 02 34 00
Puller for outer race of outside tapered roller bearing of wheel carrier bearing		115 589 00 33 00
Punch for outer race of inside tapered roller bearing of wheel carrier bearing		115 589 02 43 00
Installer for caliper with radial ball bearing on wheel carrier		116 589 05 35 00
Punch for tapered roller bearing inner race on rear axle shaft flange		116 589 09 15 00
Installer for tapered roller bearing outer races and radial sealing ring of wheel carrier bearing		116 589 11 61 00
Assembly tool for removal and installation of rear axle shaft in rear axle shaft flange as well as for inner race of inside tapered roller bearing and inside radial sealing ring of wheel bearing		116 589 24 61 00
Dial gauge holder		136 589 04 21 00

35-360 R and R caliper carrier and hub, adjust wheel bearing

Conventional tool

Two-arm puller for removing caliper from wheel carrier

e.g. made by Nexus, 5630 Remscheid
order No. 100 Gr. 2

- 37 Rear axle shaft complete
- 70 Slot nut
- 71 Radial sealing ring
- 72 Thrust washer (sealing ring)
- 73 Tapered roller bearing, inner
- 74 Spacing sleeve
- 76 Tapered roller bearing, outer
- 77 Radial sealing ring
- 78 Rear axle shaft flange
- 79 Hex bolt M8 (2nd and 3rd version)
- 79a Clamping disc
- 79b Spacing sleeve
- 90 Coupled semi-trailing arm
- 91 Wheel carrier
- 92 Protective ring
- 93 Radial sealing ring
- 94 Tapered roller bearing, outside
- 95 Tapered roller bearing, inside
- 96 Washer
- 97 Self-locking nut
- 98 Cap
- 99 Brake caliper
- 100 Radial ball bearing
- 101 Locking ring
- 102 Protective ring
- 103 Locking ring

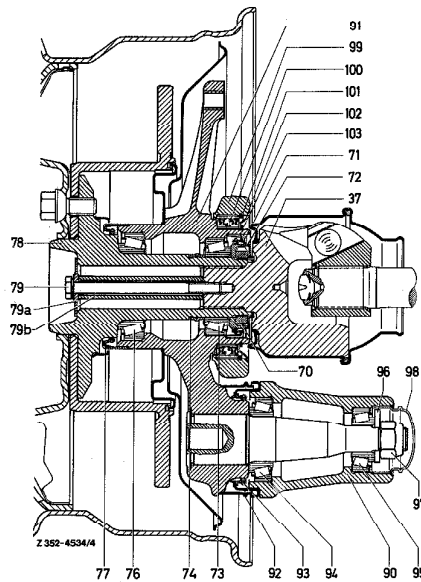

Note

Reconditioning jobs on rear axle shaft flange bearing can also be made with rear axle installed (35-130).

Removal

- 1 Remove coupled semi-trailing arm (35-310).
- 2 Remove caliper, brake disc and parking brake (42-530).
- 3 Clamp rear axle shaft flange with assembly plate (01) into vise.

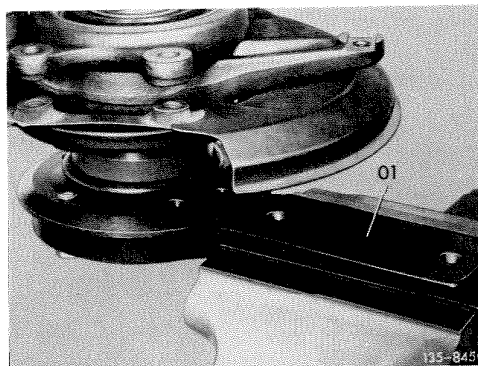

35-360 R and R caliper carrier and hub, adjust wheel bearing

4 Remove brake cable control (42-525).

5 Unscrew brake carrier, brake carrier plate and cover plate.

6 Unscrew caliper from link bolt.

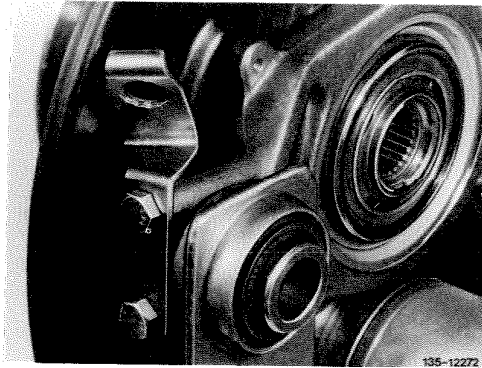

7 Remove locking ring and remove together with protective ring.

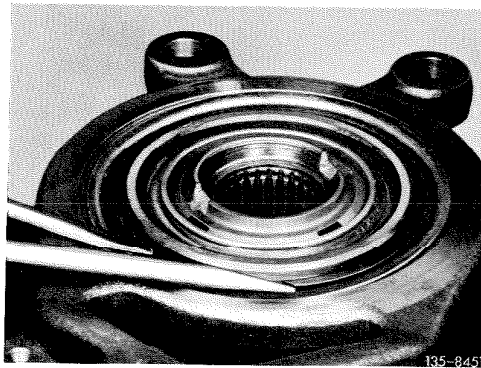

8 Pull caliper carrier with radial ball bearing from wheel carrier.

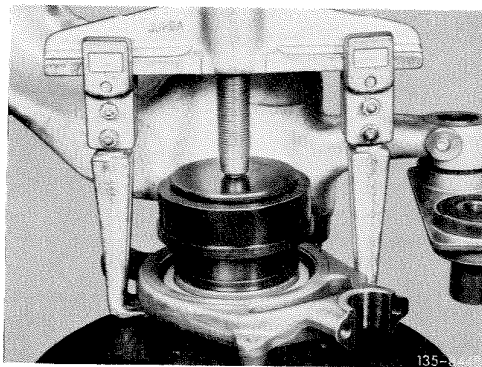

9 Remove locking ring and push radial ball bearing out of caliper carrier.

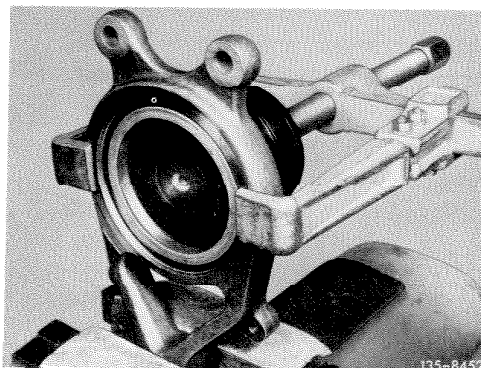

35-360 R and R caliper carrier and hub, adjust wheel bearing

10 Unlock slot nut on rear axle shaft flange and unscrew.

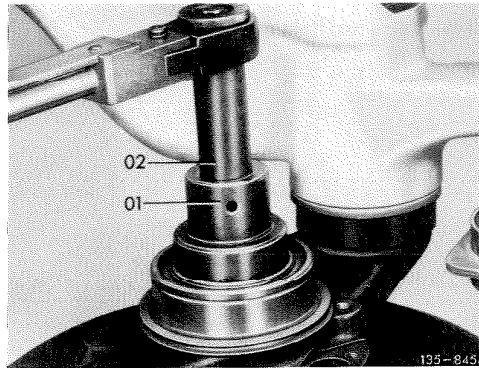

11 Remove sealing ring and push off radial sealing ring uniformly by means of a screwdriver.

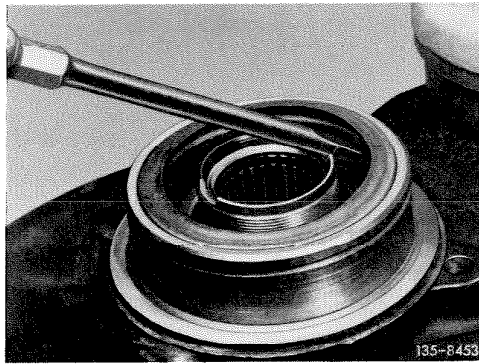

12 Push wheel carrier from rear axle shaft flange by means of two-arm puller and thrust piece (01). Remove wheel carrier with coupled semi-trailing arm and inner race of inside tapered roller bearing.

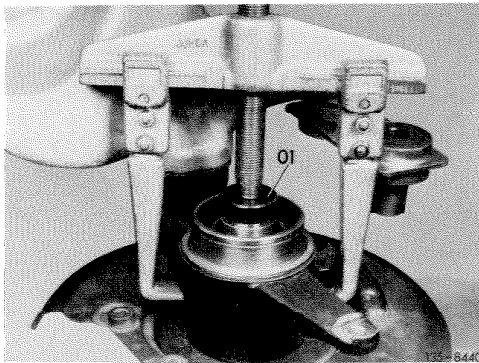

13 Remove spacing sleeve from rear axle shaft flange.

14 Pull inner race of outside tapered roller bearing from rear axle shaft flange by means of puller.

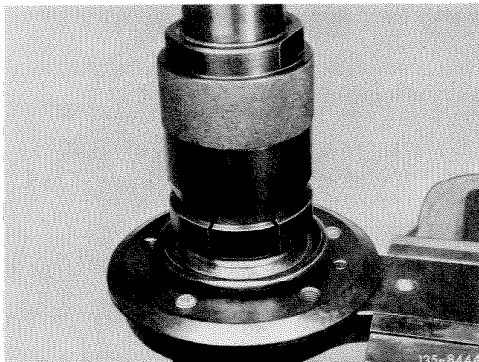

35-360 R and R caliper carrier and hub, adjust wheel bearing

15 Knock outer radial sealing ring from wheel carrier.

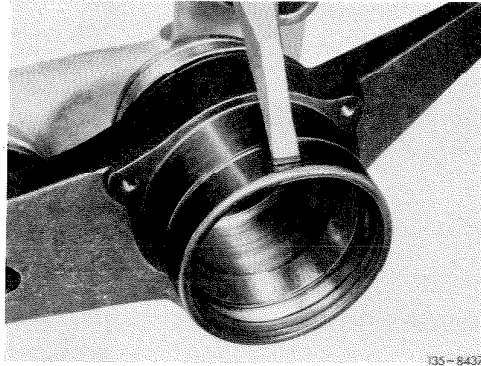

16 Pull outer race of outside tapered roller bearing from wheel carrier.

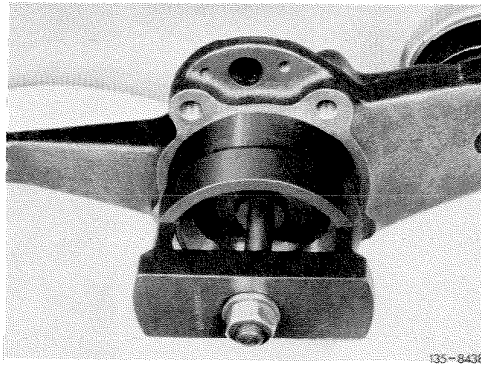

17 Knock outer race of inside tapered roller bearing out of wheel carrier.

18 Check parts for re-use. Renew worn and damaged parts.

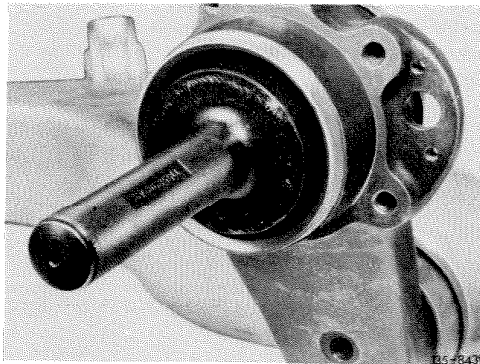

19 Check rear axle shaft flange for vertical and lateral runout.

Note: The rear axle shaft flanges are provided with an oil return spiral on running surface for outer radial sealing ring, which differs for lefthand and righthand side. For identification, the chamfer for concentric alignment is provided with a punched-in "R" for righthand side and a punched-in "L" for lefthand side.

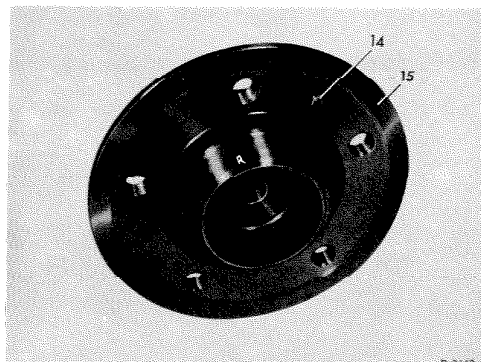

35-360 R and R caliper carrier and hub, adjust wheel bearing

20 If required, refinish oil return spiral with emery cloth (grain 180) at an angle of approx. 20 for a length of 20 mm.

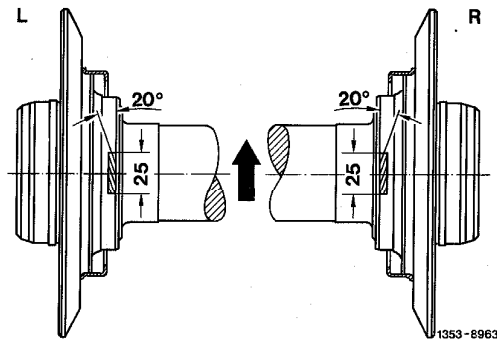

Installation

Attention!

Install rear axle shaft flanges with large fillet only (arrow).

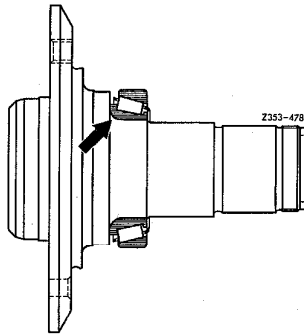

21 Press inner race (16) of outside tapered roller bearing on rear axle shaft flange (15).

Attention!

Use tapered roller bearing with large fillet for inner race only.

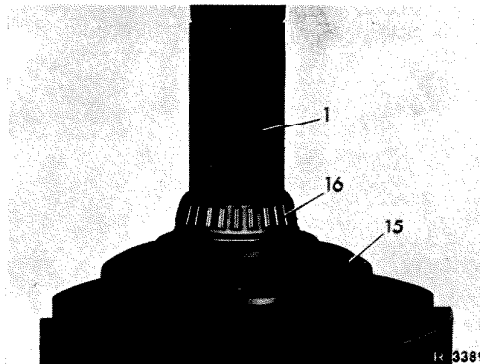

22 Press radial ball bearing into caliper carrier with remover and installer up to stop and secure with locking ring.

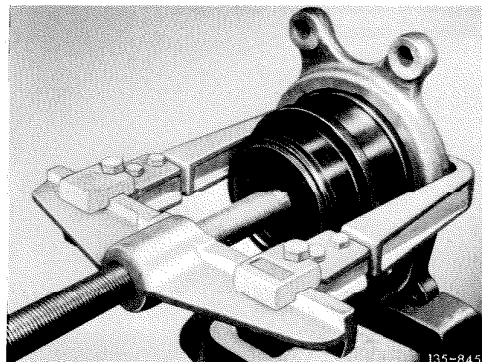

35-360 R and R caliper carrier and hub, adjust wheel bearing

23 Press caliper carrier with radial ball bearing on wheel carrier by means of installer (01).

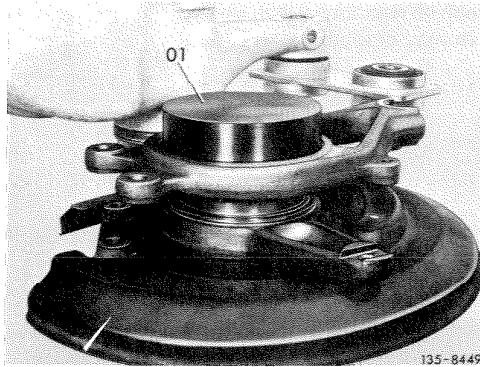

24 Mount protective ring and secure with locking ring.

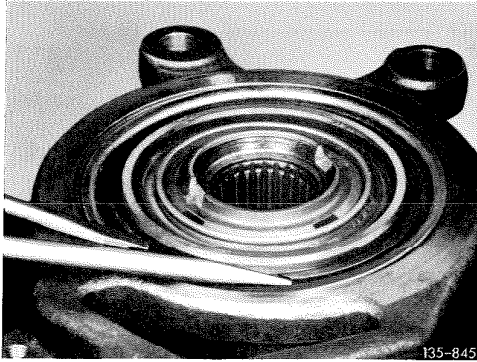

25 Attach brake caliper carrier with brake hose holder to link bolt and tighten to 25 Nm by means of hex. screws.

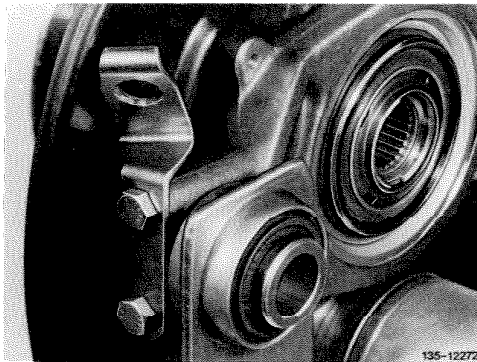

26 Install outer races of both tapered roller bearings into wheel carrier by means of installer (01).

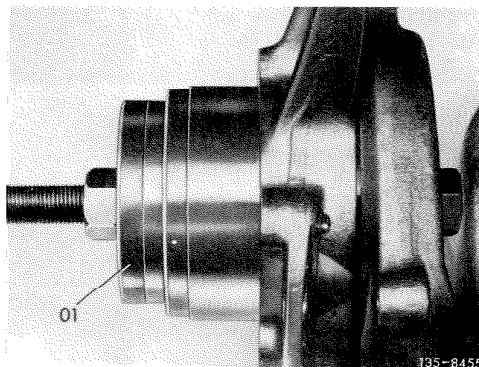

35-360 R and R caliper carrier and hub, adjust wheel bearing

27 Coat seat for outer radial sealing ring on wheel carrier with sealing compound and carefully mount new radial sealing ring by means of installer (01) in such a manner that ring rests against shoulder of wheel carrier.

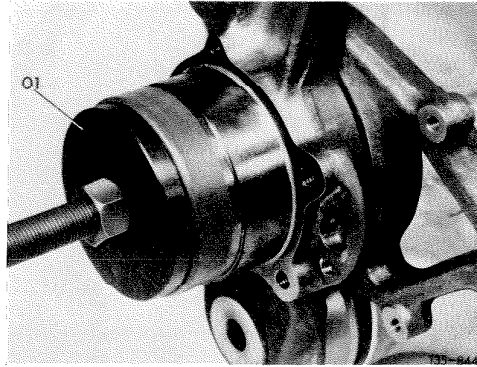

28 Fill cavity between the two bearing outer races in wheel carrier with specified multi-purpose grease.

29 Mount cover plate, brake carrier plate and brake carrier on wheel carrier.

30 Place new spacing sleeve (width 11.8–12.0 mm) on rear axle shaft flange and introduce rear axle shaft flange into wheel carrier.

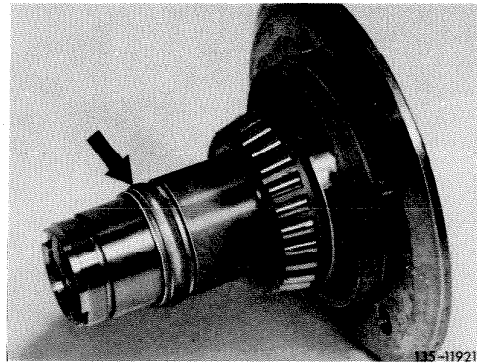

31 Slip inner race on rear axle shaft flange. Fill new inner radial sealing ring between both sealing lips with multi-purpose grease. Coat radial sealing ring with sheet metal jacket at OD with sealing compound. Mount radial sealing ring with partially rubberized jacket in dry condition. Press-in bearing inner race and radial sealing ring together by means of assembly tool (01).

32 Mount sealing race and screw-on new slot nut.

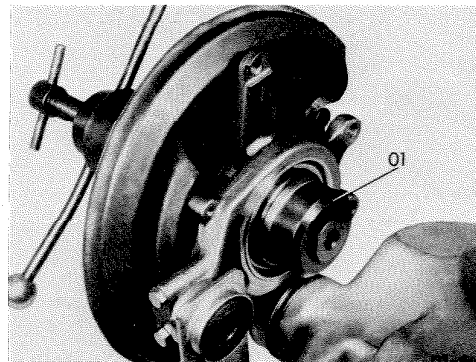

Adjustment of wheel bearing

33 Attach dial gauge holder to wheel carrier.

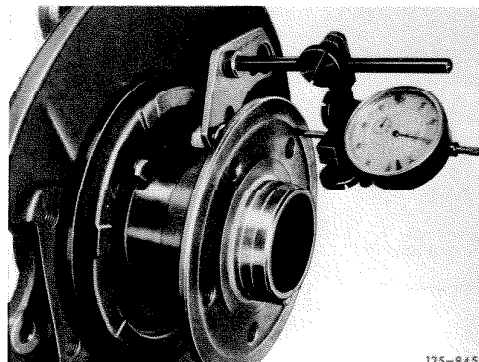

35-360 R and R caliper carrier and hub, adjust wheel bearing

34 Adjust end play (0.04–0.06 mm) of rear axle shaft flange by tightening slot nut. Turn rear axle shaft flange several times and check end play at several points.

Attention!

If the slot nut has been tightened too much and there is no more end play, do not correct end play by releasing slot but always install a new spacing sleeve and adjust end play once again.

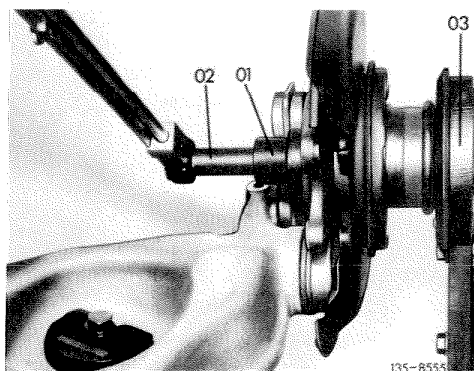

35 Secure slot nut by bending at two points into respective slots in rear axle shaft flange.

36 Install brake cable control (42-525).

37 Install parking brake, brake disc and caliper (42-530).

38 Install coupled semi-trailing arm (35-310).

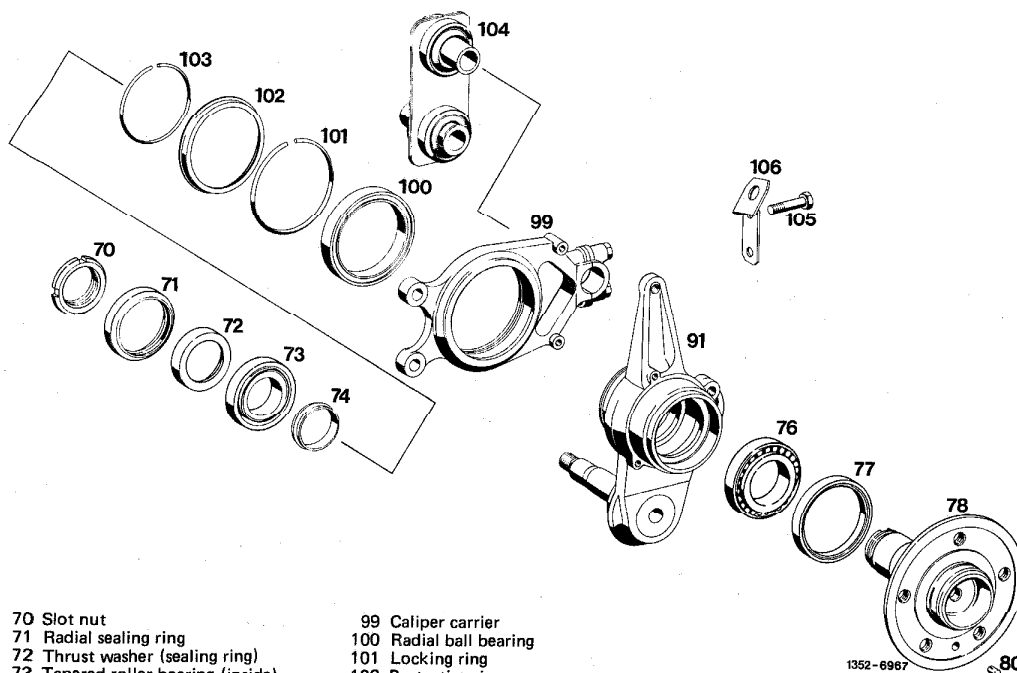
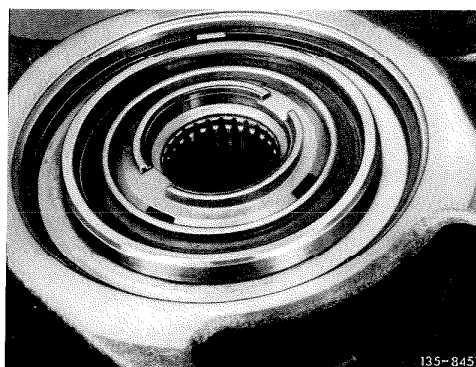

- | | |
|-------------------------------------|-------------------------|
| 70 Slot nut | 99 Caliper carrier |
| 71 Radial sealing ring | 100 Radial ball bearing |
| 72 Thrust washer (sealing ring) | 101 Locking ring |
| 73 Tapered roller bearing (inside) | 102 Protective ring |
| 74 Spacing sleeve | 103 Locking ring |
| 76 Tapered roller bearing (outside) | 104 Link |
| 77 Radial sealing ring | 105 Hex bolt |
| 78 Rear axle shaft flange | 106 Brake hose holder |
| 80 Fitted notched pin (cyl. pin) | |
| 91 Wheel carrier | |