

32-120 Checking shock absorbers

Preliminary work:
 R and R front shock absorbers (32-100).
 R and R rear shock absorbers (32-110).

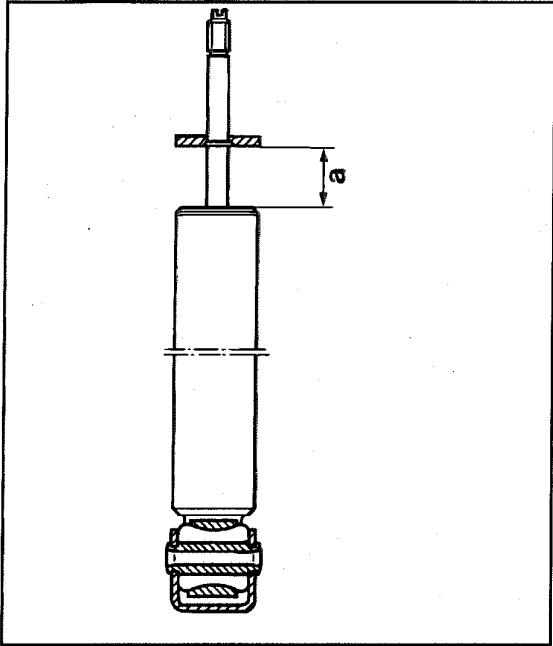

P32-5278-15

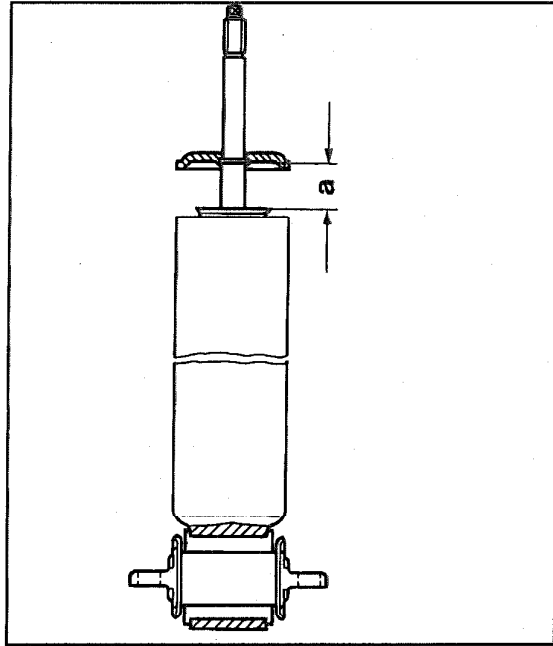

P32-5279-15

Front shock absorbers
 a Piston rod extension dimension

Rear shock absorber
 a Piston rod extension dimension

Visual check

Piston rod check for surface damage and bending.

Checking oil reserve

Oil reserve check by determining extension dimension "a" with piston rod completely retracted (see table of "Test values").

Rumbling and rattling noises

Upper mount check for proper assembly.

Bottom mount ensure that rubber bushing is seated tightly in housing eye. Check operating piston for tight seat (item 4).

32-120 Checking shock absorbers

Hissing noises

Shock absorbers with hissing noises replace (item 4).

Disposal of used shock absorbers

Observe all disposal regulations dispose of shock absorbers.

Test values for shock absorbers

Front shock absorbers

Gas pressure shock absorbers with separating piston

Designation	Part no.	Color code (for front shock absorbers: on housing; for rear shock absorbers: on bottom suspension eye)	Adjustment values for adjustment in N at 100 strokes per minute and 50 mm stroke for new or exchanged shock absorbers		Check for oil reserve in shock absorber Piston rod extension "a" 1)	
			Extension	Compr.	Values for new shock absorbers mm	Maximum permissible values mm
Bilstein	126 323 05 00	1 blue lengthwise stripe	580	320	6 ± 2	38
	126 323 06 00	2 blue lengthwise stripes	700	430		
F & S	126 323 11 00	1 blue crosswise stripe	580	320		
	126 323 12 00	2 blue crosswise stripes	700	430		
Bilstein Boge F & S	126 323 14 00	1 blue lengthwise stripe	580	320		
	126 323 15 00	2 blue lengthwise stripes	700	430		
	126 323 17 00	4 blue lengthwise stripes	480	260		
	126 323 18 00	1 green lengthwise stripe	540	255		

1) After exceeding the maximum piston rod extension value the effect of the shock absorber decreases.

32-120 Checking shock absorbers

Rear shock absorbers

Gas pressure shock absorbers with separating piston

Designation	Part no.	Color code (on bottom of suspension eye)	Adjustment values for adjustment in N at 100 strokes per minute and 50 mm stroke for new or exchanged shock absorbers		Check for oil reserve in shock absorber Piston rod extension "a" 1)	
			Extension	Compr.	Values for new shock absorbers mm	Maximum permissible values mm
Bilstein	126 326 06 00	1 blue stripe	1 300	600	0 + 2	32
	126 326 07 00	2 blue stripes	1 600	690		
	126 326 17 00	1 green stripe	1 165	495		
F & S	126 326 09 00	1 blue stripe	1 300	540		
	126 326 10 00	2 blue stripes	1 600	690		
	126 326 16 00	1 green stripe	1 165	495		
Boge	126 326 12 00	1 blue stripe	1 300	540		

1) After exceeding the maximum piston rod extension value the effect of the shock absorber decreases.

Note

On model 126 only gas pressure shock absorbers with separating piston between the oil and gas chambers are used (installed position with piston rod pointing up).

Visual check

- Carefully check the piston rod for surface damage.
- Check piston rod for bending. A bent piston rod binds in the guide bushing when it is pushed in.

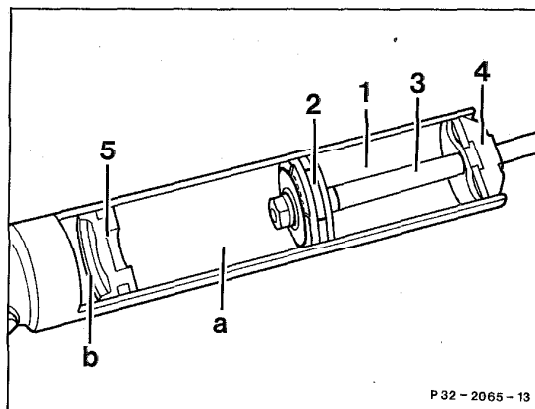

P 32 - 2065 - 13

P32-2065-13

- Cylinder
- Operating piston with spring plates
- Piston rod
- Sealing package with piston rod seal and piston rod guide
- Separating piston
- a Oil chamber
- b Gas chamber

Note

The piston rod is laid out to have a slight oil film for lubrication of the piston rod guide outside of the piston rod seal.

Rumbling and rattling noises

The alignment of the mounting points is important for proper function of the piston rod seal. For this reason always check whether the alignment of the mounting points is okay if the piston rod seal leaks.

3 Check top mount for proper installation, mounting bracket on bottom mount and rubber bushing in housing eye for tight seat.

4 Determine oil reserve quantity. When the oil loss is extremely high, shock absorbers with separating pistons tend to rattle because the piston rod can hit against the separating piston on retraction.

On rear shock absorbers check alignment of top mounting point on frame floor and bottom mounting point on semi-trailing arm (32-126).

Note

A loose operating piston can also be the cause for rattling noises.

To check installation position of shock absorber press piston rod in, release and press in again. If the operating piston is loose, the change-over from compression and extension will be accompanied by a rattling or knocking noise.

32-120 Checking shock absorbers

Hissing noises

Shock absorbers with separating piston cause hissing noises when the separating piston is leaky, because gas gets into the oil system and forms foam.

Such shock absorbers may still function, but still have to be replaced.

Checking the oil reserve

Note

The oil reserve in the shock absorber can be determined by the piston rod extension "a". The temperature of the shock absorber should be approx. 20 °C when measuring the oil reserve. In the event of oil loss the piston rod extension increases.

After exceeding the permissible extension value, replace shock absorbers, because the effect decreases.

5 Press piston rod in to operating piston stop on separating piston.

6 Measure extension dimension "a" and compare with values in table.

Note

When damaged shock absorbers can be replaced individually regardless of the brand. It is only necessary for the shock absorber version to coincide according to color code, e.g. 1 blue stripe or 2 blue stripes.

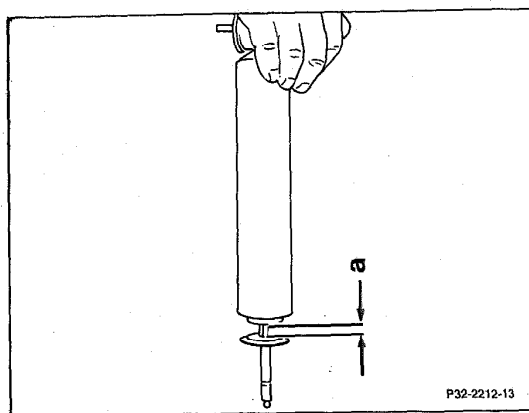

P32-2212-13

Disposing of used shock absorbers

Always observe all applicable **safety precautions, also observe federal state, and local regulations** when disposing of used shock absorbers.