

The M-Class



Mercedes-Benz



On: comfort
Off: routine

The M-Class comfort experience begins before you even turn the engine on. The marvellously spacious cabin with its fine materials immediately creates a sense of well-being. Like everything else about the M-Class, it helps you leave the routine behind.



High: safety
Low: stress

Sitting higher means seeing further. So you are literally in a better position for an anticipative driving style. This reduces stress and allows you to enjoy to the full the feeling of effortless superiority at the wheel of the M-Class. High road or no road? With our advanced technology it really doesn't matter.







↑: Comfort
↓: Effort



+ Power
- Emissions





The new M-Class makes its presence felt with its powerful, sporty appearance and its outstanding tractive power. But it is also a model of restraint where the environment is concerned. Numerous intelligent measures improve its efficiency and keep the fuel consumption down accordingly. A case in point is the ML 250 BlueTEC 4MATIC which consumes just 6 litres per 100 km (combined figure).

The **irresistible** charisma of the new M-Class is matched in equal measure by its sparing use of resources. Its integrated BlueEFFICIENCY measures are designed for maximum sustainability while its powerful engines also have impressively low fuel-consumption and emission figures. Various measures to optimise efficiency, such as the ECO start/stop function, fuel-saving tyres and the radiator shutter, make the new M-Class the trailblazer for a new generation of SUVs which acknowledge their responsibility towards the environment.

- New generation of 4 and 6-cylinder diesel engines (ML 250 BlueTEC 4MATIC and ML 350 BlueTEC 4MATIC)
- New generation of BlueDIRECT V6 engines with direct petrol injection
- Emission class Euro 6 for BlueTEC diesel engines, Euro 5 for petrol engines
- 7G-TRONIC PLUS automatic transmission, optimised to offer maximum efficiency at any given engine speed and reduced fuel consumption
- ECO start/stop system as well as instantaneous fuel consumption display
- Ancillaries - such as fuel pump and power steering pump - controlled to save energy
- On-demand activation of air conditioning compressor
- Fuel-saving tyres with low rolling resistance
- Optimised aerodynamics and radiator shutter

The **new M-Class** is the sum of all the safety concepts developed by Mercedes-Benz throughout the history of the brand. As a result, you have a feeling of complete control in the commanding driving position and can even specify your vehicle with options which allow it to monitor the traffic around you, adjust its headlamps automatically and check that you are alert at all times. In fact, your M-Class is more than a vehicle, it's a companion.

- 4MATIC permanent all-wheel drive, supported by the Electronic Stability Program ESP® and the electronic traction system 4ETS
- ATTENTION ASSIST as standard
- Optional Intelligent Light System with Adaptive Highbeam Assist for optimum illumination of the road (available from Q2 2012)
- Optional Night View Assist Plus (available from Q2 2012)
- PRE-SAFE® preventive occupant protection system
- Airbags and sidebags for driver and front passenger, kneebag for driver, windowbags for all seats, rear sidebags as an option
- Active bonnet offers improved protection for other road users
- High seating position for a commanding view and a relaxing driving experience
- Optional Driving Assistance package Plus comprising DISTRONIC PLUS including PRE-SAFE® Brake, BAS PLUS, Active Blind Spot Assist, and Active Lane Keeping Assist

Effortlessly superior. The M-Class

Strong characters attract each other. The elegant, powerful lines underline the self-assured presence of the new M-Class. The distinctive design of the new generation is reflected both in the overall impression it creates and in the many new styling details, such as the expressive front bumper and the modified side skirts. Together, these measures ensure that the M-Class is as pleasing to look at as it is to drive.

- LED daytime running lamps standard for all model variants
- Running boards available as an optional extra
- Panoramic sliding sunroof from windscreen to rear of vehicle (optional)
- New light-alloy wheels in various sizes and finishes
- Wide choice of paint finishes, interior colours, trim elements and upholstery
- Extensive individualisation options, such as the Mercedes-Benz Interior Sports package, the AMG Exterior Sports package and the designo Exclusive package
- Fine interior with ARTICO man-made leather door lining, trim elements in wood and wood/leather steering wheel (optional)
- Dashboard and beltline in ARTICO man-made leather (optional)
- Multi-coloured ambient lighting (optional)

Routine is one thing you won't find in this SUV. Installed comfortably in your seat, you can enjoy the M-Class experience to the full. As you do so, you will find that the spacious interior, as well as being particularly accommodating, provides the perfect acoustic environment for appreciating the output of the optional multimedia system – another way in which the new M-Class can take you places which no other vehicle can reach.

- DIRECT SELECT lever and steering-wheel shift paddles standard for all models
- All-Road Performance: with 4MATIC, optionally with AIRMATIC package, ACTIVE CURVE SYSTEM or ON&OFFROAD package
- Optional KEYLESS-GO
- Extremely quiet running
- Front seats electrically adjustable for height and backrest angle as standard
- Memory package (optional): fully power-adjustable front seats, steering column and exterior mirrors with memory function, including electrically adjustable 4-way lumbar support in front seats
- Flexibility: load compartment capacity of 680 to 2010 litres, maximum towing capacity of 3500 kg
- Optional COMAND Online web-enabled multimedia system with hard-disc navigation and high-resolution colour display
- Climate comfort: THERMATIC automatic air conditioning fitted as standard, THERMOTRONIC luxury automatic climate control with separate temperature control for driver, front passenger and rear seat available as an option
- Optional reversing camera
- Two temperature-controlled cup holders (optional)
- Active Parking Assist with PARKTRONIC (optional)

AIRMATIC package and ON&OFFROAD package

In vehicles equipped with the optional AIRMATIC package, the AIRMATIC air suspension with adaptive shock absorbers adjusts to the current road and driving conditions optimally and so ensures greater stability for both on and off-road driving as well as improved dynamics at high speeds. The driver can choose between sporty and comfort-oriented suspension modes and can set the ride height. Ground clearance remains constant, regardless of the load, thanks to the all-round self-levelling function. Downhill Speed Regulation, which is fitted as standard, allows a preset speed to be maintained when negotiating steep descents. If the vehicle is equipped with the optional ON&OFFROAD package, the driver can adjust the settings for the ride height, the transfer case and the manual gearshift program by means of control buttons in the centre console. A rotary switch allows any of six pre-programmed driving modes, including “Offroad”, “Sport” and “Snow”, to be selected as required by the driver. What’s more, if COMAND Online (optional) is fitted, the driver can call up additional information, such as the vehicle’s current angle of inclination, at the touch of a button.



Standard equipment

The new M-Class offers excellent ride comfort and flexibility as standard. THERMATIC automatic air conditioning maintains the right interior temperature during the journey and the front seats are electrically adjustable. Steering is made particularly effortless by the Direct-Steer system while the DIRECT SELECT lever and shift paddles on the multifunction steering wheel make changing gear a pleasure. 4MATIC makes for optimum traction on all surfaces and ATTENTION ASSIST can give a warning if the driver's concentration begins to lapse. Quiet running is another significant attribute of the new M-Class. Innovative LED tail lights add the literal finishing touch to the exclusive elegance of the new M-Class.



The aluminium trim elements underline the high quality of the interior



The 1/3:2/3 split rear bench seat is particularly practical when there are bulky loads to be carried



ATTENTION ASSIST can trigger a visual warning and an audible alarm



Unmistakable look: the new LED tail lights

Optional extras

The new M-Class is also well ahead of the crowd in the areas of safety and comfort - with the optional Memory package, for example: this allows three different sets of positions for the front seats, head restraints, steering column and exterior mirrors to be stored and recalled at the touch of a button. The COMAND Online multimedia system with hard-disc navigation and an optimised map display on a large, central colour screen (17.8-cm diagonal) now includes extended off-road functions as well as an integrated web browser. When used in combination with a web-enabled mobile phone, the online function is able to provide access to the internet and various mobile services offered by Mercedes-Benz. Driving pleasure and safety are raised to even higher levels by the AIRMATIC package, the Lane Tracking package, the ACTIVE CURVE SYSTEM and the Intelligent Light System with bi-xenon headlamps. Additional support for the driver is provided by assistance systems, such as Active Blind Spot Assist and Active Parking Assist with PARKTRONIC. Pedestrians and obstacles can be seen at an early stage thanks to Night View Assist Plus while Sports packages for the interior and exterior are available to give the new M-Class an even more distinctive look.



Night View Assist Plus: your second sight in the dark



The Intelligent Light System with bi-xenon headlamps



Large panoramic sliding sunroof



The ambient lighting creates a pleasant interior atmosphere



Active Blind Spot Assist is able to warn the driver about a vehicle in the blind spot



Sporty and exclusive: the Interior Sports package



The AMG Exterior Sports package gives the new M-Class an even more irresistible look



The web-enabled COMAND Online multimedia system



The Interior Sports package enhances the new M-Class with a range of attractive extras



A new dimension of sportiness: the AMG Exterior Sports package for the new M-Class

NON-METALLIC PAINTS

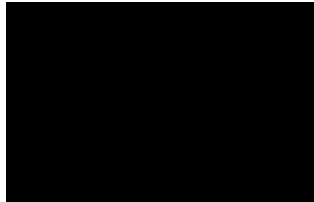

040 black

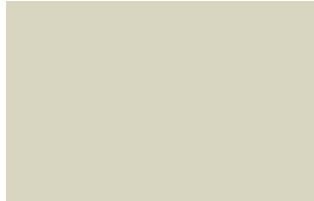

650 calcite white

METALLIC PAINTS¹

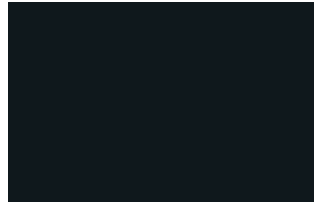

197 obsidian black



359 tanzanite blue



755 tenorite grey



775 iridium silver



792 palladium silver

METALLIC PAINTS¹



794 pearl beige

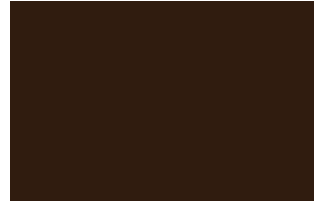

796 citrine brown

SPECIAL METALLIC PAINTS¹

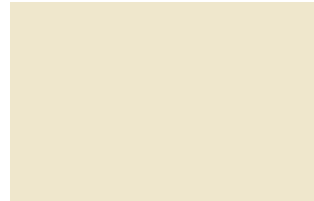

799 diamond white metallic BRIGHT

BLACK



001 ARTICO leather²/fabric



101²|201 Leather¹



739 Aluminium with longitudinal grain



734 brown eucalyptus wood¹



731 brown burr walnut wood¹



729 anthracite poplar wood¹



H09 brown ash wood¹

ALPACA GREY



108²|208 Leather¹



739 Aluminium with longitudinal grain



734 brown eucalyptus wood¹



731 brown burr walnut wood¹



729 anthracite poplar wood¹



H09 brown ash wood¹

¹ Optional extra

² ARTICO man-made leather

ALMOND BEIGE



BLACK/ALPACA GREY



BLACK/ALMOND BEIGE



BLACK/TOBACCO BROWN



105²|205 Leather¹



258 Leather¹



255 Leather¹



254 Leather¹



739 Aluminium with longitudinal grain



739 Aluminium with longitudinal grain



739 Aluminium with longitudinal grain



739 Aluminium with longitudinal grain



734 brown eucalyptus wood¹



734 brown eucalyptus wood¹



734 brown eucalyptus wood¹



734 brown eucalyptus wood¹



731 brown burr walnut wood¹



731 brown burr walnut wood¹



731 brown burr walnut wood¹



731 brown burr walnut wood¹



729 anthracite poplar wood¹



729 anthracite poplar wood¹



729 anthracite poplar wood¹



729 anthracite poplar wood¹



H09 brown ash wood¹



H09 brown ash wood¹



H09 brown ash wood¹



H09 brown ash wood¹

Dimensions

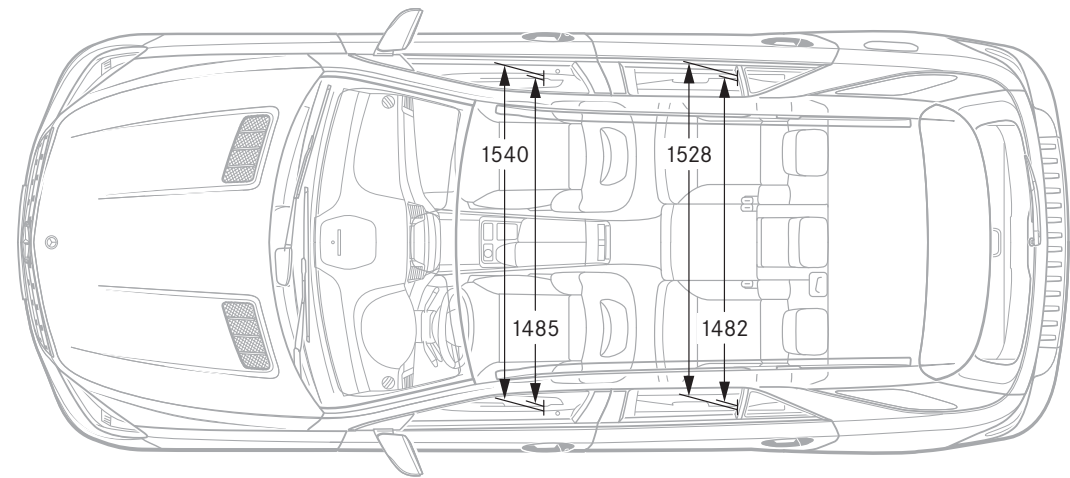
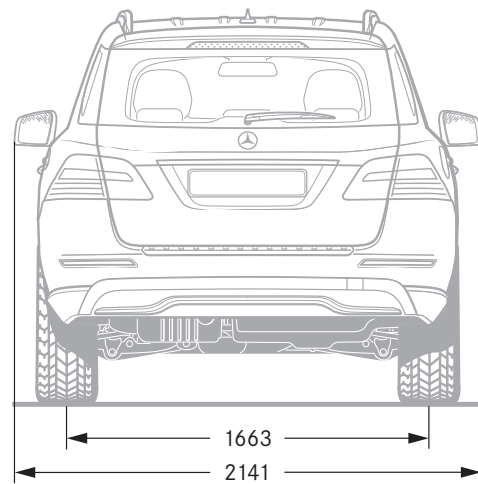
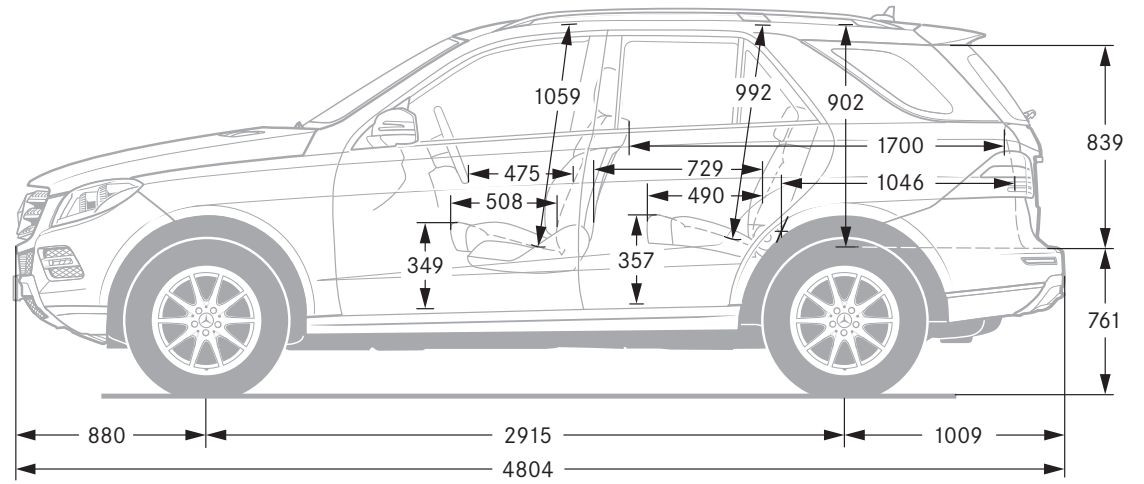
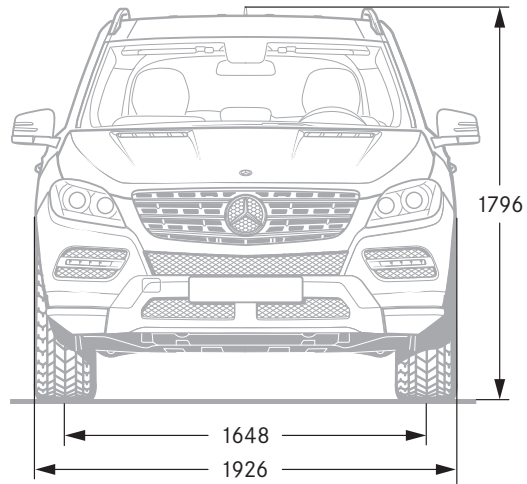

All measurements in millimetres. The dimensions shown are mean values and apply to standard-specification, unladen vehicles

Technical data

	DIESEL ENGINE		PETROL ENGINE
	ML 250 BlueTEC 4MATIC	ML 350 BlueTEC 4MATIC	ML 350 4MATIC BlueEFFICIENCY
No. of cylinders/arrangement	4/in-line	6/V	6/V
Transmission	7G-TRONIC PLUS	7G-TRONIC PLUS	7G-TRONIC PLUS
Total displacement (cc)	2143	2987	3498
Rated output ¹ (kW at rpm)	150/4200	190/3600	225/6500
Rated torque ¹ (Nm at rpm)	500/1600–1800	620/1600–2400	370/3500–5250
Acceleration from 0 to 100 km/h (s)	9.0	7.4	7.6
Top speed, approx. (km/h)	210	224	235
Fuel consumption ² (l/100 km)			
urban	7.0–7.6	7.8–8.4	10.9–11.3
extra-urban	5.4–5.8	6.3–6.8	7.1–7.4
combined	6.0–6.5	6.8–7.4	8.5–8.8
CO ₂ emissions ² (g/km) comb.	158–170	179–194	199–206
Emissions standard	Euro 6	Euro 6	Euro 5
Tank capacity (l), incl. reserve, approx.	70/11.0	70/11.0	78/10.0
Boot capacity (l)			
max. behind 2 nd row of seats	690	690	690
max. behind 1 st row of seats	2010	2010	2010
Turning circle diameter (m)	11.80	11.80	11.80
Kerb weight ³ /perm. GVW (kg)	2150/2950	2175/2950	2130/2900
Permissible towing capacity braked/unbraked (kg)	2950/750	3500/750	3500/750

¹ Figures in accordance with Directive 80/1269/EEC in the currently applicable version ² The figures shown were obtained in accordance with the prescribed measuring process (Directive 80/1268/EEC in the currently applicable version). The figures are not based on an individual vehicle and do not constitute part of the product offer; they are provided solely for purposes of comparison between different vehicle models ³ Figures in accordance with Directive 92/21/EC, version 95/48/EC (kerb weight with fuel tank 90% full, driver, 68 kg, and luggage, 7 kg) for standard-specification vehicles. Optional extras and accessories will generally increase this figure and reduce the payload capacity accordingly

Take-back of end-of-life Vehicles. Coming full circle. At the end of its long life, you can return your M-Class to us for environment-friendly disposal in accordance with the EU End-Of-Life Vehicle Directive¹. But that day lies a long way off.

¹ Applies in accordance with national regulations to vehicles up to 3.5 tonnes permissible gross weight. Mercedes-Benz passenger cars have met the statutory regulations governing the suitability of their design for reuse and recycling for a number of years now. A network of vehicle take-back depots and dismantlers has been established which will process your vehicle in an environment-friendly manner. The ways in which both vehicles and parts can be recovered are subject to ongoing development and improvement. Consequently, the M-Class will be able to comply with any future increases in the recycling quota within the stipulated time limits. For further information please visit www.mercedes-benz.com

Please note: changes may have been made to the product since this brochure went to press (29.04.2011). The manufacturer reserves the right to make changes to the design, form, colour and specification during the delivery period, provided these changes, while taking into account the interests of the vendor, can be deemed reasonable with respect to the purchaser. Where the vendor or the manufacturer uses symbols or numbers to describe an order or the subject of an order, no rights may be derived solely from these. The illustrations may show accessories and items of optional equipment which are not part of standard specification. Colours may differ slightly from those shown in the brochure, owing to the limitations of the printing process. This brochure is distributed internationally. It provides a general indication of the range of models, features, optional extras and/or colours available in various countries. Some of the models, features, optional extras and/or colours shown may not be available in your country or may only be available in a different specification. Additionally some models, features, optional extras and/or colours may only be available in combination with others. For current and more specific information in relation to the range of models, features, optional extras and/or colours available in your country, and their pricing, you should contact your nearest authorised Mercedes-Benz Passenger Car Dealer. www.mercedes-benz.com