

The C-Class Saloon and Estate



Mercedes-Benz

ign and materials. A new generation with its own rules. You can have it all. But with e
ynamic Handling package. Responsible-minded on the other thanks to BlueEFFICIENC
and provocative front section – sets the heart racing. The comfort and convenience fea
look: a new dashboard, new surfaces, new trims. A revolution of inner values. The C-C
ch the style. A new generation: individual and spontaneous. Its purpose is to serve. Its
o of the way. With the optional COMAND Online system, which makes every driver a d
easure. True perfection: nothing needs to be added or taken away. The C-Class Estate le
s as standard. And LED tail lights which first draw you in and then cast their spell. Im
ve people. And it can be a load carrier: with up to 1500 litres of stowage space, a paylo
its trump cards. The C-Class Estate has it all: a dashboard trimmed in wood or alumin
in every detail. **A class ahead.** The C-Class: it knows exactly where it comes from and wh
eneration with its own rules. You can have it all. But with enjoyment comes responsib



Saloon. The new-generation C-Class goes its own way simply because it can. Confident and captivating in appearance with a powerful, masculine exterior. Seductive and appealing in character thanks to a fresh, stylish interior and intelligent details such as the optional PARKTRONIC and Becker® MAP PILOT systems. Thrilling in essence courtesy of options such as the Dynamic Handling package and 4MATIC. And that's not all: up to ten assistance systems available as optional extras, efficient engines and rich details with a piano-lacquer-look finish. The new-generation C-Class: a class ahead.

At a glance | from page 4 Insight | from page 28

Estate. The C-Class Estate: proof that practicality can go hand in hand with excitement. Exciting thanks to a provocative front section with distinctive features, dynamic headlamps and a powerful bumper. Reassuring courtesy of optionally available safety features and assistance systems normally the reserve of the luxury class, which always keep an eye on the driver and the road. Spacious on account of plenty of room for easy loading. Future-compatible by virtue of the outstanding efficiency provided by spirited engines with BlueEFFICIENCY. But, above all, an interior with an extensively modified dashboard and visible luxury. The C-Class Estate races ahead: a class ahead.

At a glance | from page 16 Insight | from page 28

The C-Class Saloon and Estate

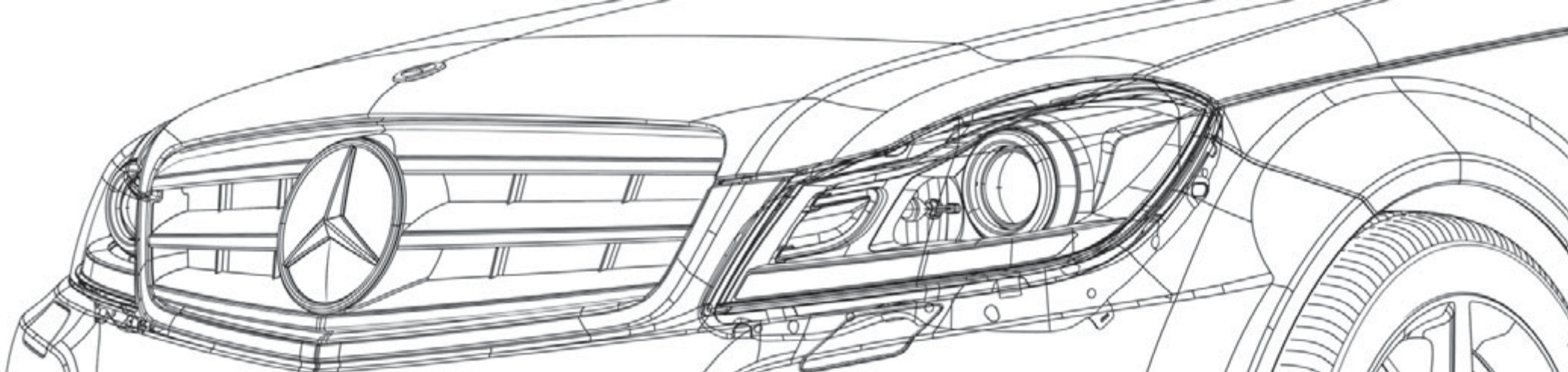

Perfection in motion: diesel and petrol engines, transmissions, chassis and suspension.

Drive system & chassis | from page 36

All-round protection: state-of-the art technology for safe driving and the right response in the event of danger or an accident.

Safety | from page 46

More luxury per mile: from multimedia and assistance systems to climate control and the Estate's versatile load compartment.

Comfort | from page 50

High-performance sport as standard: the equipment for the C 63 AMG and the options available from the AMG Performance Studio.

AMG | from page 62

All about the driver: design and equipment lines and packages, designo, standard equipment and optional extras, wheels and genuine accessories.

Equipment & appointments | from page 70

All-round service: Mercedes-Benz Museum, MercedesCard, Mercedes-Benz Financial Services, Mercedes-Benz mobility, service packages, test drive, Interactive Owner's Manual, mobile internet.

Services | from page 96

Impressive in every detail: dimensions, paintwork and technical data.

Facts & colours | from page 98

They say nothing's perfect.
We beg to differ





The C-Class knows exactly where it comes from and where it wants to go. Its aspiration is to lead, its path onwards and upwards. Incorporating outstanding technology, design and materials. A new generation with its own rules.





Outclasses even the stiffest of opposition

You can have it all. But with enjoyment comes responsibility. Agile on the one hand thanks to the AGILITY CONTROL suspension with selective damping and the optional Dynamic Handling package. Responsible-minded on the other thanks to BlueEFFICIENCY and direct injection. Uncompromisingly rational: live for today and think of tomorrow.

→ Page 36-41, 44, 45

A close-up, low-angle shot of the front of a dark-colored Mercedes-Benz C-Class car. The car is moving rapidly, as indicated by the blurred background and light trails. The front grille, featuring the Mercedes-Benz logo, and the license plate 'S C 2525' are clearly visible. The license plate has a blue strip on the left with the letter 'D' and a yellow 'HYBRID' badge. The car's headlights and bumper are also visible.

As impressive inside as it is outside

The beguiling form of the C-Class – with its powerful and provocative front section – sets the heart racing. The comfort and convenience features then calm it down again: up to ten assistance systems, latest-generation telematics, optional climatized seats. With style wherever you look: a new dashboard, new surfaces, new trims. A revolution of inner values.





Never accept less. Except when it comes to emissions

Save fuel, reduce emissions: be it the ECO start/stop function or the enhanced aerodynamics, BlueEFFICIENCY shows the way ahead. Without compromising on performance, dynamism or sportiness. Now less really does mean more.

→ Page 36, 37





What lies beneath the pristine surface?
More pristine surfaces







Just let your heart
and mind rule together





The C-Class Estate: as attractive as it is intelligent. In a highly desirable form with all the functionality you could wish for. Now there is space to match the style. A new generation: individual and spontaneous. → Page 58-61

Comfort has never
been more exciting





Its purpose is to serve. Its true nature to seduce. The C-Class Estate achieves this with the optional Driving Assistance package Plus, which can protect you every step of the way. With the optional COMAND Online system, which makes every driver a decision maker. And with an impressive load capacity, which places great emphasis on freedom. Wilful disobedience: adrenaline for driving pleasure.



True perfection: nothing needs to be added or taken away. The C-Class Estate leads by example. With enhanced stature and a more mature appearance. New wheels sharpen the side profile. A fine chrome handle comes as standard. And LED tail lights which first draw you in and then cast their spell. Impressive details wherever you look.

First impressions count.
And so do lasting ones





Size is also a matter of inner values

The C-Class Estate can be a lounge: with plenty of space, kneeroom and shoulder room for up to five people. And it can be a load carrier: with up to 1500 litres of stowage space, a payload of up to 540 kilograms and, as an option, the intelligent EASY-PACK load compartment management system. Spaciousness is one of its trump cards. → Page 58-61





Even the inside can be a best side

Always appropriate and in the proper style. The C-Class Estate has it all: a dashboard trimmed in wood or aluminium, for example, a steering wheel in nappa leather, and a high-resolution colour display in the instrument cluster. Sweeping change: immaculate in every detail.









Inspiration from high above

A classic, pale yellow manor house on the shore of Lake Como with a sign bearing the name “Villa Salazar”. What looks like an aristocratic retreat actually houses the Mercedes-Benz Advanced Design Studio – speciality interior design. Around 20 designers, modellers and engineers have been working here since 1998, leaving no stone unturned in their quest to make future Mercedes models as comfortable and enjoyable as possible for the driver and passengers. It is the perfect environment for our aesthetes: the Como – Milan – Turin triangle is

the hub of the Italian fashion and leather industry, where haute couture meets traditional craftsmanship. For the creative teams, this means exciting experiments with new forms, materials and finishes – and new ideas. And if they need inspiration, they can just look above and around them, as the villa’s ceilings and walls are painted with lavish, baroque frescos. The resulting designs – such as the interior of the C-Class – are timelessly elegant and comfortable, with every last detail perfectly conceived.



BOSCH

BANKOOK STIHL

I ♥ [Mercedes-Benz logo]

Mercedes-Benz Service

It's a C-Class – but not as you know it

When it exercises restraint, it has the familiar character of a compact-class Mercedes. Out on the race circuit, it's a different story as its true nature emerges. The C-Class – an unprecedented success story in the DTM.

1988: Mercedes-Benz and the motorsport experts from AMG first entered the DTM, four years young at the time. Lining up at the start was a 190 E 2.5-16 model, a racing version of the famous precursor to the C-Class. Mercedes promptly took this car to second place in the DTM championship and went on to secure a position on the podium in the years that followed: 1991 and 1993 runner-up, 1992 and 1994 DTM winner with the first genuine C-Class – a triumph repeated in 1995, 2005 and 2006.

The 2010 season was the most successful to date for Mercedes-Benz and AMG: the C-Class took first place in nine out of eleven races and so secured the DTM championship for Paul Di Resta. This triumph proved once and for all that a C-Class should never be underestimated.



ment. Multimedia systems. kW at rpm. In the event of danger. Assistance systems. Seats.
ery. Trim. g/km. Wheels. Services. Nm at rpm. Trim. Dimensions. Following an accident.
Interior. Technical data. Rated output. In the event of an accident. Emission class. Top
ior. Diesel engines. Transmissions. Comfort. Following an accident. Interior. Total disp
s. Climate control. Equipment packages. Total displacement. Optional extras. Safe driv
nt. Paintwork. Petrol engines. Technical data. Airbags. Acceleration. c_d value. Chassis.
op speed. cc. l/100 km. Standard equipment. Trim. Sustainability. Services. Accelerati
l data. CO₂. Chassis. Fuel. Fuel consumption. Assistance systems. Seats. Climate contr
es. Nm at rpm. Trim. Dimensions. Following an accident. Paintwork. Diesel engines. T
ems. kW at rpm. In the event of danger. Assistance systems. Seats. Climate control. Eq
eels. Services. **The facts.** Nm at rpm. Trim. Dimensions. Following an accident. Paintw
Technical data. Rated output. In the event of an accident. Emission class. Top speed. cc

36 **BlueEFFICIENCY**38 **Diesel engines**

4-cylinder
6-cylinder

40 **Petrol engines**

4-cylinder
6-cylinder

42 **Transmissions**

6-speed manual transmission
7G-TRONIC PLUS

44 **Chassis & suspension**

4MATIC all-wheel drive
AGILITY CONTROL suspension
Sports suspension
Dynamic Handling package

46 **Safe driving**

Lane Keeping Assist/Blind Spot Assist
ATTENTION ASSIST
DISTRONIC PLUS
Intelligent Light System

48 **In the event of danger or an accident**

PRE-SAFE® system
NECK-PRO head restraints
Airbags

50 **Multimedia systems**

COMAND Online
Audio 20 CD
Harman Kardon® Logic 7®
surround sound system
Becker® MAP PILOT

52 **Assistance systems**

Speed Limit Assist
Reversing camera
PARKTRONIC incl. Parking Guidance

54 **Climate control**

THERMOTRONIC
THERMATIC
Rear climate control

56 **Seats**

Seats
Climatised seats
Memory package

58 **Space**

Load compartment
Load compartment cover

60 **Load compartment management**

EASY-PACK load-securing kit
Self-levelling suspension
EASY-PACK tailgate

The C-Class Saloon and Estate in detail

62	C 63 AMG exterior	70	Design and equipment lines, incl. upholstery and trim	96	Services	98	Dimensions
64	C 63 AMG interior		Standard equipment		Mercedes-Benz Museum	98 101	Paintwork
			ELEGANCE line		MercedesCard		
66	C 63 AMG technology		AVANTGARDE line		Mercedes-Benz Financial Services		99
	AMG 6.3-litre V8 engine	82	Equipment packages		Mercedes-Benz mobility		Technical data
	AMG sports suspension		AMG Sports package		Service packages		
	AMG SPEEDSHIFT MCT		designo		Test drive		
	7-speed sports transmission				Interactive Owner's Manual		
					Mobile internet		
68	AMG Performance Studio	88	Standard equipment				
		90	Optional extras				
		92	Wheels				
			Standard wheels				
			Optional wheels				
			AMG wheels				
			Genuine accessory wheels				
		94	Genuine accessories				

BlueEFFICIENCY – Fast forward to tomorrow

We are quicker at getting environmentally friendly future technologies to where it matters most: on the road. As the inventor of the motor car, Mercedes-Benz has a special responsibility – one we have undertaken with all our might for many years. By the end of 2011, we will be able to offer you 128 models with BlueEFFICIENCY technologies, all of which help you reduce your impact on the environment – without compromising on safety, comfort and driving enjoyment.

Our BlueEFFICIENCY concept comprises innovations for efficient mobility as well as optimised processes all the way along the value chain. They involve different approaches, but they all have a common goal: to make your individual mobility as sustainable as possible.

The BlueEFFICIENCY measures – the Mercedes-Benz efficiency package. This package consists of comprehensive vehicle optimisations designed to save fuel and ease the burden on the environment. Each model combines the most efficient engine with latest-generation aerodynamic and energy-management measures to minimise fuel consumption. Such measures include

intelligently controlled ancillaries, tyres with optimised rolling resistance, lightweight components and the ECO start/stop function, which is being made available for an increasing number of models. The new BlueDIRECT V6 and V8 petrol engines, which feature in several model series, deliver a much higher power output while reducing fuel consumption by up to 24%.

BlueTEC – the clean diesel. Mercedes-Benz has brought to market BlueTEC technology for diesel engines based on common-rail direct injection (CDI). A modular emission-control system makes BlueTEC an exceptionally clean diesel technology, as not only does it remove up to 95% of the particulate matter from the exhaust gases, it also reduces nitrogen oxides by up to 90%. What remains is mainly water, nitrogen and the satisfying feeling of having helped to ease the burden on the environment.

HYBRID – petrol and electric drives intelligently combined. A well-established team makes a lot of things easier. And this is certainly true in the case of HYBRID technology. Here the electric motor is used for the recuperation of kinetic energy. This energy is stored in the battery and returned to the electric drive when needed, which assists the petrol engine when the car is accelerating. What's more, the ECU shuts off the petrol engine when the speed is below 15 km/h. In this way, a HYBRID can reduce fuel consumption by up to 20%. So it looks after the environment as well as your bank balance. Perfect teamwork, you might say.



The BlueEFFICIENCY measures bring about a substantial reduction in fuel consumption and CO₂ emissions



BlueTEC HYBRID – clean diesel combined with electric drive. It marries the benefits of the HYBRID with those of BlueTEC: during braking, the kinetic energy is converted into electrical energy, which can be re-used when required. At the same time, the BlueTEC technology cleans exhaust gases and removes many of the pollutants. All of which makes the economical diesel powerplant even more efficient, agile and clean.



Using the E-Class as a basis, we are developing a diesel hybrid equipped with **BlueTEC HYBRID Technology**

Innovative drive systems that break new ground: E-CELL and F-CELL. Mercedes-Benz has developed two locally emission-free drive systems known as the E-CELL and F-CELL. The B-Class F-CELL is already being produced on a small scale and has been displaying its everyday practicality on Germany's roads since mid-2010. It uses hydrogen to produce power for the electric motor in a fuel cell. The first vehicles from a small series of the A-Class E-CELL – which features an electric motor that draws its energy from two lithium-ion batteries, giving it an average range of more than 200 km – began rolling off the production line at the end



The A-Class **E-CELL** allows locally emission-free driving with a battery-powered electric motor

of 2010. An E-CELL PLUS is also scheduled for release, which will include a small internal combustion engine combined with a generator to increase the range of the electric vehicle.

But that is not all: under the banner “Design for Environment”, we also look at a vehicle's entire lifecycle and work hard to preserve the environment from the planning stage right through to recycling. The same applies to the building and running of new plants. In addition, we are heavily involved in the development of alternative fuels and carry out research in the field of bionics. In short, BlueEFFICIENCY is good news for both you and the environment.

Further information about our comprehensive measures can be found at:

www.mercedes-benz.com/blueefficiency

Diesel engines

Cleaner, more powerful and more economical: the C-Class also signals the launch of the latest Mercedes-Benz diesel technology. The powerful and quiet engines impress with their low emission and fuel-consumption figures.

4-cylinder in-line engines. The 4-cylinder diesel unit with a choice of four power outputs displays a high level of sophistication: it offers impressively rich torque and instantaneous response, even at low revs. What's more, the diesel engines consume less fuel, have low emissions and are both quiet and powerful.

This is made possible by a wealth of innovative technologies. Fourth-generation common-rail diesel technology impresses by virtue of an injection pressure increased to 2000 bar, optimised combustion chambers and extremely precise injectors. Higher ignition pressure and the turbocharger make for high torque in every engine speed range, while the requisite refinement comes courtesy of two Lanchester balancer shafts. Optimised alternator management ensures consistent use of the engine's coasting phases, thus allowing recuperation of kinetic energy. Meanwhile the radiator shutter reduces the

aerodynamic drag when the engines require only moderate cooling. The current engine generation delivers impressive output and high torque as well as reduced fuel consumption and CO₂ emissions. All 4-cylinder diesel engines now feature the ECO start/stop function.

The 4-cylinder diesel engines comply with the Euro 5 emissions standard and are available with the following outputs:

- C 180 CDI BlueEFFICIENCY developing 88 kW and a peak torque of 300 Nm
- C 200 CDI BlueEFFICIENCY developing 100 kW and a peak torque of 360 Nm
- C 220 CDI BlueEFFICIENCY developing 125 kW and a peak torque of 400 Nm
- C 250 CDI BlueEFFICIENCY developing 150 kW and a peak torque of 500 Nm

V6 engines. The C 350 CDI BlueEFFICIENCY also places the emphasis on efficiency. In its latest guise, the updated and consumption-optimised V6 diesel engine develops 195 kW, making it the most powerful diesel drive system with common-rail technology in the C-Class. Precise and fast injectors, a high injection pressure of up to 1600 bar, and an optimised turbocharger combine to produce an immense peak torque of 620 Nm – all of which adds up to effortlessly superior pulling power in all driving situations. In combination with 4MATIC all-wheel drive, the 6-cylinder diesel engine in the C-Class is also available as the C 300 CDI 4MATIC BlueEFFICIENCY, developing 170 kW and peak torque of 540 Nm. For all their performance potential, both 6-cylinder diesel engines still meet the requirements of the Euro 5 emissions standard, of course, and the 195-kW version is also equipped with the ECO start/stop function as standard.



The 4-cylinder diesel engine is available with a choice of four outputs (C 220 CDI BlueEFFICIENCY shown here)

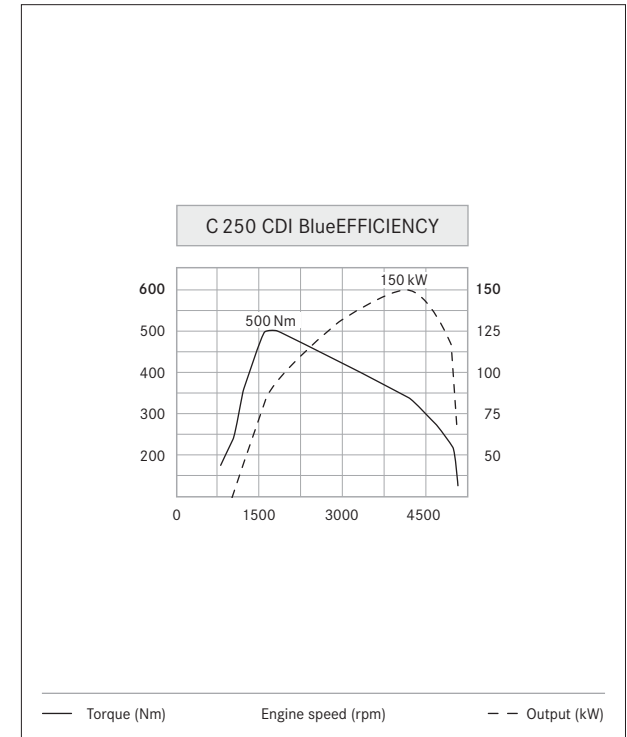

The C 250 CDI BlueEFFICIENCY posts an excellent set of output, torque and fuel-consumption figures

Petrol engines

Mercedes-Benz offers a wide range of environmentally compatible engines. New technologies reduce fuel consumption, while CO₂ emissions are lower than ever for a Mercedes-Benz C-Class.

4-cylinder in-line engines. The optimised 4-cylinder powerplant with a displacement of 1.8 litres, direct petrol injection, variable valve timing and turbocharger offers outstanding torque and power, not to mention appropriately low fuel consumption and emissions.

Fuel is used efficiently thanks to almost complete combustion, while the variable valve timing allows optimum cylinder charging and, therefore, reduces fuel consumption. Fuel consumption is also cut thanks to the reduced weight and low internal friction. Two balancer shafts ensure low engine vibration in every engine speed range.

The 4-cylinder petrol engines come with a choice of three power outputs:

- C 180 BlueEFFICIENCY developing 115 kW and a peak torque of 250 Nm
- C 200 BlueEFFICIENCY developing 135 kW and a peak torque of 270 Nm
- C 250 BlueEFFICIENCY developing 150 kW and a peak torque of 310 Nm

All engines are exceptionally quiet and meet stringent fuel consumption and emission requirements (Euro 5).

V6 engine. Over 20 % lower fuel consumption than the predecessor model and correspondingly lower CO₂ emissions yet enhanced dynamics – a neat way of summing up the C 350 BlueEFFICIENCY. These advantages are primarily down to the latest-generation direct petrol injection from Mercedes-Benz, which operates using spray-guided combustion and high-pressure injection by means of piezo injectors. Maximum output is 225 kW, while the peak torque of 370 Nm is available between 3500 and 5250 rpm. In addition to the modified combustion process, further factors which help to reduce fuel consumption include the standard-fit ECO start/stop function, a completely new air and exhaust system, controlled ancillaries, intelligent alternator management and consistently applied lightweight-design principles. Outstanding refinement is another of the new V6 engine's hallmark traits. The C 350 BlueEFFICIENCY Saloon is also available with 4MATIC all-wheel drive.



The 4-cylinder engines feature direct petrol injection, variable valve timing and a turbocharger (C 250 BlueEFFICIENCY shown here)

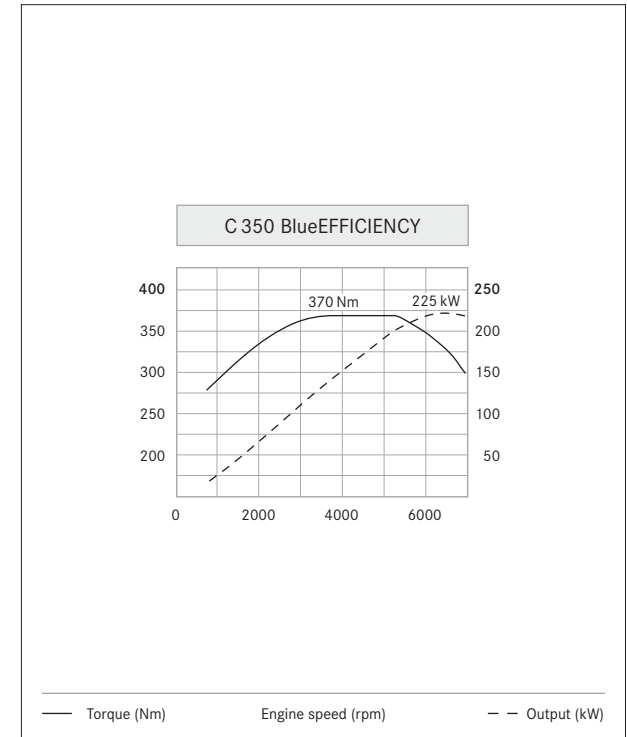

The C 350 BlueEFFICIENCY offers the ideal combination of harmonious power delivery, driving enjoyment and energy efficiency

Transmissions

Whether it be a manual gearshift or an automatic, an economical or a sporty driving style – the transmissions for the C-Class have been optimised in line with the model in which they are installed. Plus they are intuitive and ergonomic to use.

6-speed manual transmission. The 4-cylinder engines (with the exception of the C 250 BlueEFFICIENCY and models with 4MATIC all-wheel drive) are paired with a 6-speed manual transmission – with ECO start/stop function as standard – which offers impressively short, precise shift travel and whose gear spacing is optimally matched to the rear axle ratio. A display on the instrument cluster indicates recommended gear changes to further encourage a highly economical driving style.

7G-TRONIC PLUS. All V6 engines as well as models with 4MATIC all-wheel drive (with the exception of the C 300 CDI 4MATIC BlueEFFICIENCY) are paired with the efficiency-optimised 7G-TRONIC PLUS 7-speed automatic transmission as standard. This transmission is available as an optional extra for 4-cylinder models (standard for C 250 BlueEFFICIENCY). The revised 7G-TRONIC PLUS setup includes a new torque converter generation which ensures more dynamic response, greater durability, reduced noise levels and significantly lower fuel consumption. The latter is also thanks to the inclusion as standard of the ECO start/stop function,

which stops the engine temporarily when the car is stopped at traffic lights or in a traffic jam. Furthermore, the seven forward gears in the 7G-TRONIC PLUS ensure an ideally adapted engine speed at all times, short shift times and smooth shifts. Driving enjoyment is likewise enhanced: the car delivers even better acceleration and provides even more pulling power. And when changing down, gears can be skipped for fast in-gear acceleration.

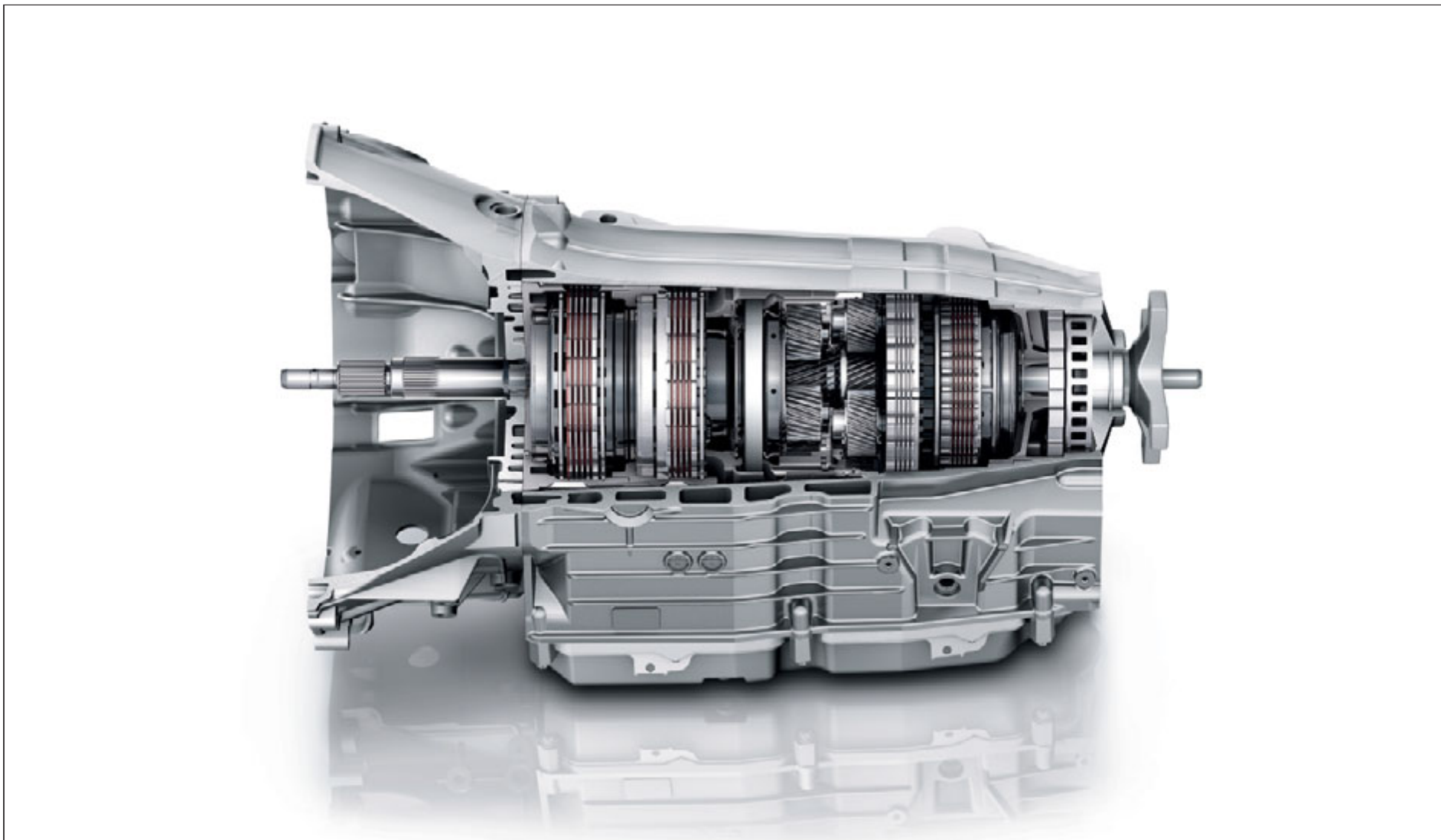

The 7G-TRONIC PLUS: one of over 18 million automatic transmissions produced in a period spanning more than 50 years

Chassis & suspension

4MATIC permanent all-wheel drive provides impressive traction as well as enhanced driving stability. The AGILITY CONTROL suspension with selective damping system really comes into its own on the road, offering a high level of comfort as well as impressive agility.

4MATIC all-wheel drive (optional). As 4MATIC is always active, it responds almost instantaneously in poor weather conditions such as rain, black ice or snow. 4MATIC is assisted by the Electronic Stability Program ESP® and the electronic traction system 4ETS. The latter enables controlled braking of spinning wheels and, as a consequence, increases the drive torque at the wheels offering good traction, allowing plenty of

power to be planted on the road when moving off and when accelerating, especially on poor road surfaces. 4MATIC makes conventional differential locks superfluous: the automatic braking pulses make it easier to move off on slippery ground as well as enhancing stability during critical manoeuvres. A further advantage of the system is the fact that it is hardly any heavier than the rear-wheel-drive version on account of the compact

design, intelligent choice of materials and high level of efficiency. 4MATIC is only available in conjunction with the 7G-TRONIC PLUS automatic transmission (C 300 CDI 4MATIC BlueEFFICIENCY with 7G-TRONIC).

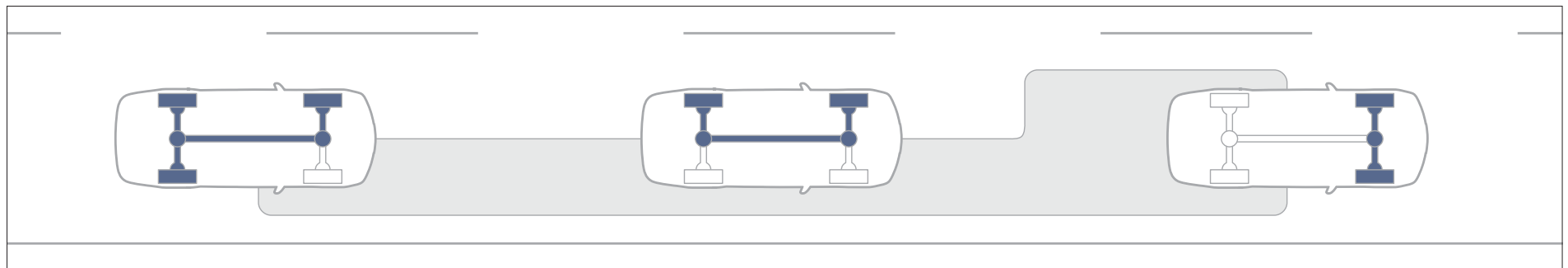

The electronic traction system 4ETS automatically sends the drive torque to the wheels offering sufficient grip

AGILITY CONTROL suspension with selective damping system (standard). The AGILITY CONTROL suspension with selective damping system combines agility and ride comfort, as the shock absorbers adjust automatically to suit the current driving situation. The enhanced damping and vehicle stability are especially beneficial on poor road surfaces.

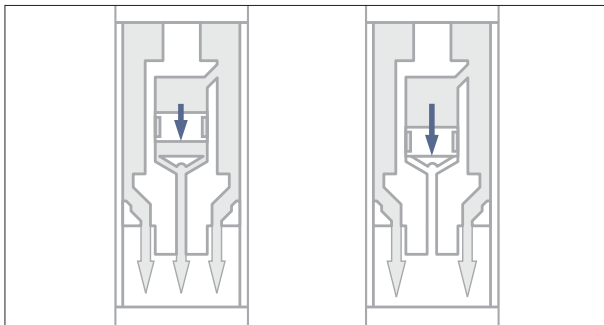

Agility with a high level of comfort – the AGILITY CONTROL suspension adjusts the shock absorbers automatically

Sports suspension (optional, standard in conjunction with AMG Sports package). The AGILITY CONTROL sports suspension with firmer settings and a body lowered by 15 mm is available as an optional extra. The springs and dampers are stiffer than those used by the standard-fit AGILITY CONTROL suspension, thus reducing body roll and enhancing driving stability. The speed sensitive sports steering's more direct ratio complements the suspension by transferring the steering movements to the road even more spontaneously.

Dynamic Handling package (optional). With the optionally available Dynamic Handling package, a touch of the Sport button is all it takes to switch the relevant systems from regular comfort mode to sports mode. Damping becomes noticeably firmer, and the engine responds far more directly to accelerator pedal movements. At the same time the automatic transmission's shift program changes to a more aggressively responsive mode, ensuring optimum acceleration figures. The speed-sensitive sports steering conveys a more direct, sporty steering feel in both driving modes.

Safe driving

The assistance systems in the C-Class can intervene before an accident happens: thanks to their awareness, even critical situations can be defused – the ideal basis for relaxed driving.

Lane Keeping Assist/Blind Spot Assist (Lane Tracking package, optional). Lane Keeping Assist detects the white markings on the road. If the car leaves its lane unintentionally, the system can warn the driver by making the steering wheel vibrate gently. Blind Spot Assist uses two radar sensors to monitor the area which cannot be seen by the driver directly alongside and behind the car – in short: if the assistance system detects the

danger of an impending collision with another vehicle when changing lanes, the driver is warned by a signal in the exterior mirror if the car is travelling at 30 km/h or more.

ATTENTION ASSIST (included with the optional luxury multifunction steering wheel). This new drowsiness detection system can be especially useful on long trips. Between 80 and 180 km/h, ATTENTION ASSIST warns the driver as soon as it detects typical signs of drowsiness or inattention. All thanks to sensors that can analyse driving behaviour and detect any changes in it.



Lane Keeping Assist can make the steering wheel vibrate if the vehicle drifts unintentionally across lane markings



Blind Spot Assist can monitor the hidden-from-view areas alongside and behind the car in order to help the driver change lanes safely



Helps to detect drowsiness at an earlier stage. ATTENTION ASSIST can remind the driver to take a break

DISTRONIC PLUS (included with the optional Driving Assistance package Plus). The DISTRONIC PLUS adaptive cruise control can help the driver to maintain the desired distance between the car and the vehicle in front by braking the car, to a standstill if necessary, and then accelerating it again. The PRE-SAFE® Brake can initiate emergency braking around 0.6 seconds before an imminent collision to reduce the severity of the accident.

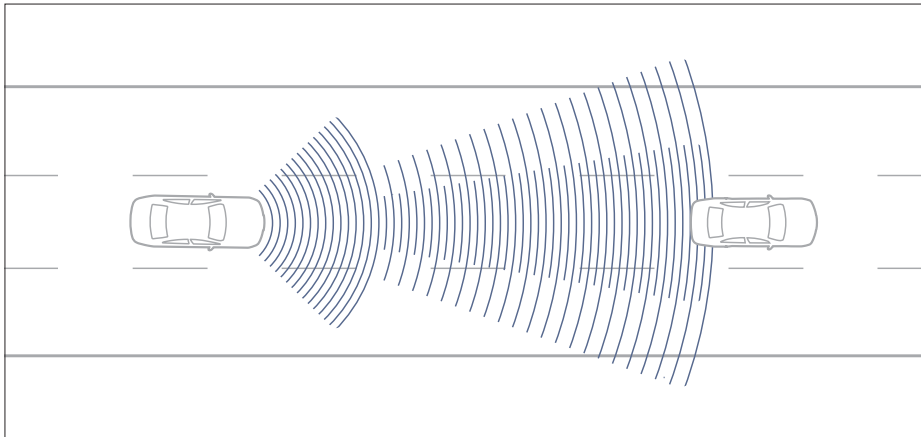

The DISTRONIC PLUS adaptive cruise control can brake the car to a standstill, for example when driving in a queue of traffic

Intelligent Light System (optional). The system has six functions: country mode, motorway mode, enhanced fog lamps, cornering light function, active light function and Adaptive Highbeam Assist. The latter provides the best possible low-beam headlamp range. The headlamps can be dimmed automatically as soon as an oncoming vehicle with its lights on is detected. The LED daytime driving lights enhance perceptual safety during the daytime.

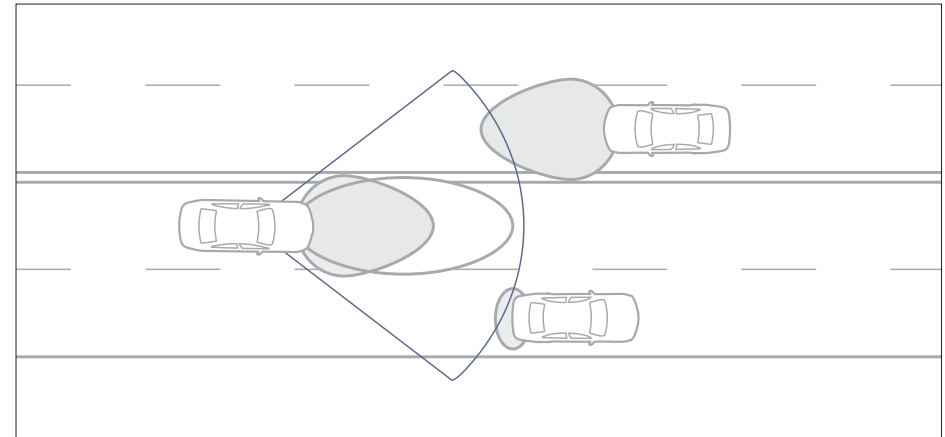

The Intelligent Light System is an adaptive headlamp system which adjusts itself automatically to the current weather, light and driving conditions

In the event of danger or an accident

Whether there's the danger of an accident or one can no longer be avoided, the C-Class does all it can to provide better protection for the driver and passengers.

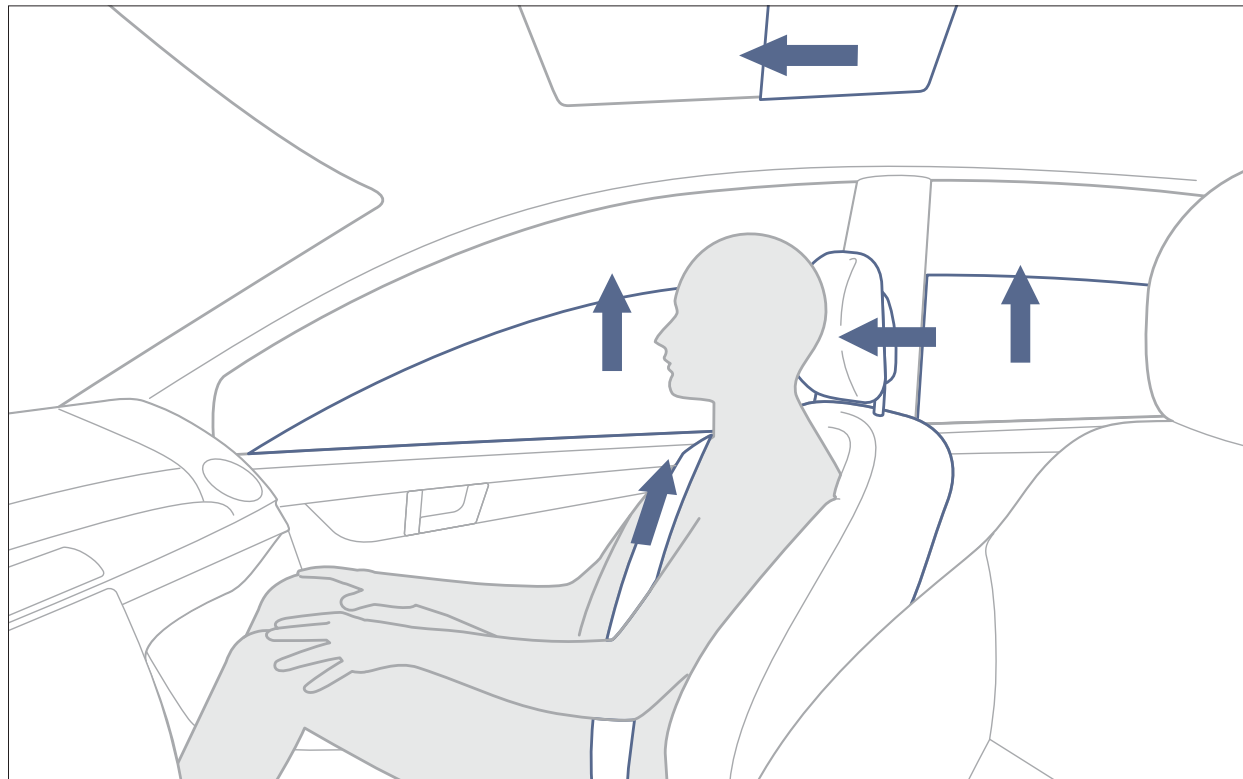

The anticipatory occupant protection system PRE-SAFE® can recognise critical driving situations and take preventive measures to protect the occupants

PRE-SAFE® system (optional). The PRE-SAFE® anticipatory occupant protection system can detect critical driving situations as they start to arise and initiate measures to protect the occupants as a precaution. The front seat belts can be tensioned, while open side windows or the sliding sunroof can be closed, depending on the driving situation and the car's specification, meaning that the seat belts and airbags can be deployed as effectively as possible should an accident occur. Air cushions in the optionally available multicontour seats can be activated within seconds to help hold the occupants in the front seats. What's more, the separately available Memory function can move the front passenger's seat into a more ideal position from an accident standpoint. If the accident is avoided, the seat belts are slackened, and the system is then ready for action again straightaway.

NECK-PRO head restraints (standard). The crash-responsive NECK-PRO head restraints can help to reduce the risk of whiplash injury by moving forwards and upwards to support the heads of the front occupants at an earlier stage in the event of a rear impact. The flexible side bolsters on the optional NECK-PRO luxury head restraints (standard for ELEGANCE line) provide additional lateral support for the head.

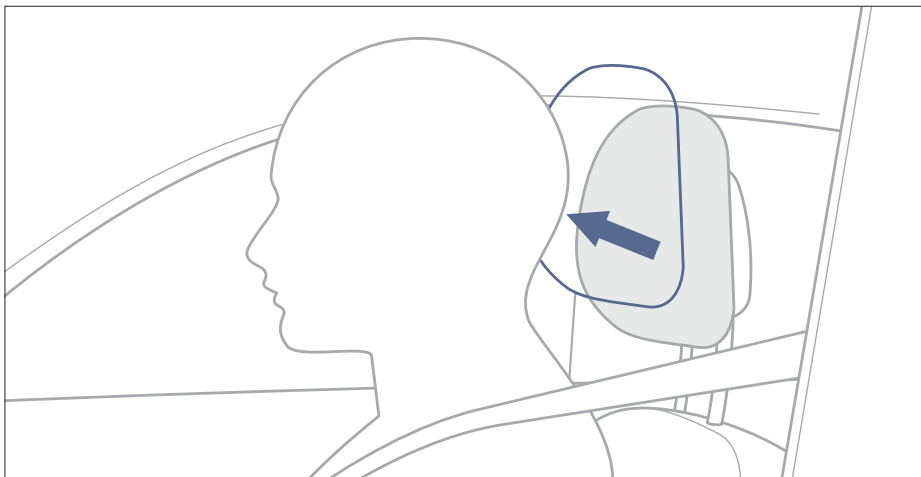

In the event of a rear impact, the NECK-PRO head restraints can move forwards by 40 millimetres and upwards by 30 millimetres in order to offer added protection

Airbags (standard). Seven airbags are fitted as standard in order to help protect the passengers: front airbags which can be deployed in two-stages, depending on the accident severity, as well as sidebags and windowbags. The kneebag can further reduce the forces exerted on the driver during an accident. Rear sidebags are available as an optional extra.

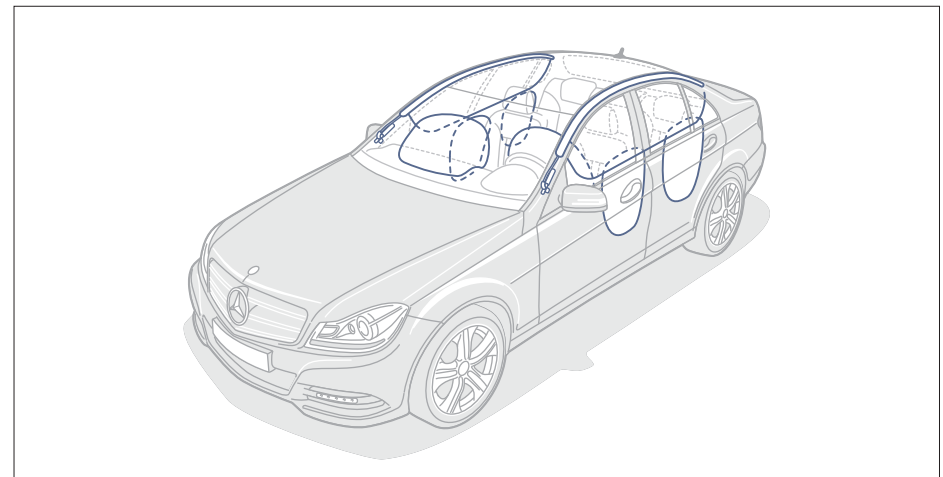

The seven airbags fitted as standard are part of the restraint systems which are decisive in helping to mitigate the consequences of accidents

Multimedia systems

The C-Class offers a full range of entertainment systems, from the Audio 20 and the optional Audio 20 system with Becker® MAP PILOT to the optional COMAND Online multimedia system.



COMAND Online is a combination of audio and navigation systems as well as telephone and internet functions. All of the main settings can also be programmed using the LINGUATRONIC voice-operated control system

COMAND Online (option). The multimedia system boasts a high-resolution 17.8-cm colour display. The system's functions include a radio, speed-sensitive volume control, the MUSIC REGISTER with a 10-GB hard disc and hard-disc navigation. What's more, for 3 years from the initial registration it also includes free updates for European map data. The best in entertainment comes courtesy of the DVD drive which plays CDs and MP3 content as well as video and audio DVDs. The online function with integrated web browser facilitates access to the internet plus various mobile services from Mercedes-Benz via an internet-capable mobile phone. A USB and an Aux-in socket, a slot for SD memory cards and a Bluetooth® interface enable connections to external data carriers and a mobile phone. The system is operated via a Controller that can be used intuitively and also via the buttons on the multifunction steering wheel. LINGUATRONIC allows you to operate COMAND Online by voice entry.

Audio 20 CD (standard). The Audio 20 system combines the key functions of a fully-fledged entertainment system: radio, CD player, MP3 player, Aux-in socket, USB and Bluetooth® interfaces. Following the introduction of the new telematics generation, the screen diagonal was increased to 14.7 cm. Optional extras also include a 6-disc CD changer and the universal Media Interface.



A Bluetooth® interface with hands-free system and the Audio 20 system with telephone keypad facilitate mobile communication

Harman Kardon® Logic 7® surround sound system (optional). Equipped with 12 loudspeakers, including a woofer, and a 9-channel DSP sound amplifier, this optionally available Dolby Digital 5.1 system has an output of 450 watts, giving you first-class acoustics in all seats when combined with the COMAND Online system. 3D surround sound and speed-sensitive volume control ensure constant listening pleasure.



12 loudspeakers and 450 watts for the ultimate listening experience: the Harman Kardon® Logic 7® surround sound system

Becker® MAP PILOT (option). The new Becker® MAP PILOT has everything you look for in a fully featured navigation system. Fully integrated, it can be operated via the central control and also the display of the Audio 20 CD. What's more, it can be individualised by downloading current map data and additional functions. A cradle for the control unit in the glove compartment allows the system to be used flexibly and to be removed from the vehicle.



The extensive functions of the Becker® MAP PILOT are shown on the Audio 20 CD display and the instrument cluster

Assistance systems

The C-Class has always been a car in which convenience has played a major role. And thanks to convenience-enhancing assistance systems such as Speed Limit Assist Plus, Parking Guidance and the reversing camera, it more than lives up to this reputation.



Speed Limit Assist Plus can even indicate temporary speed limits

Speed Limit Assist (included with the optional COMAND Online system). Speed Limit Assist can detect speed-limit signs and display them as symbols on the instrument cluster. They remain displayed there until the speed restriction is lifted or changed. To this end, a windscreen-mounted camera monitors the area in front of the car on a permanent basis. The camera can filter out round traffic signs, be they speed-limit signs at the side of the road or on a gantry above the road. To detect the signs, the system also scans the data stored on the navigation system's digital map, thus also enabling the identification and display of the signs seen when entering or leaving some towns and villages. Speed Limit Assist is especially helpful on routes with variable speed limits or road works. In addition, Speed Limit Assist compares the signposted speed limits with the data stored in the navigation system.

Reversing camera (optional). The reversing camera with wide-angle lens films the area directly behind the car and sends the images to the COMAND display. It is activated when reverse gear is engaged, thus enhancing safety when reversing into a parking space. The reversing camera is only available in conjunction with COMAND Online.



The reversing camera provides additional assistance when reversing into a parking space

PARKTRONIC incl. Parking Guidance (optional).

PARKTRONIC can warn the driver automatically if space in front of or behind the car becomes tight when parking or manoeuvring. The system operates on the echo sounder principle, Sensors on the front and rear bumpers emit ultrasound signals which are then reflected by other vehicles or obstacles. A microcomputer calculates the current distance and informs the driver by means



The display in the instrument cluster gives you a clear picture of what is happening at all times when parking

of displays in the instrument cluster and audible signals. Parking damage can therefore be prevented.

Parking Guidance can help the driver when parking and when looking for a parking space: ultrasonic sensors in the side front bumper can measure the length of parking spaces parallel to the car automatically if the car drives past at a speed of 35 km/h or less. Parking Guidance starts once a suitable space has been found and reverse gear has been engaged. It provides the driver with visible and audible instructions regarding the correct steering angle as well as the turn-in and turn-back points on the instrument cluster. If the car is not straight after the first reversing move, the system also helps the driver with the required manoeuvring moves.

Climate control

An ideal interior climate is paramount when it comes to ensuring a high level of driver-fitness and stress-relieving safety. This is why the climate control system for the C-Class is exceptionally versatile and can be adjusted to meet the needs of each individual occupant.



The THERMOTRONIC automatic climate control system operates extremely effectively without producing draughts. It is easy to use, fast to respond and quiet. The control wheels have been redesigned and finished with a silver-chrome surface for the C-Class.

THERMOTRONIC (optional). The THERMOTRONIC luxury automatic climate control system allows the driver, front passenger and rear passengers each to set the temperature using their own controls. Additional air outlets in the B-pillars and a booster blower beneath the centre console ensure the ideal temperature in the rear. What's more, the automatic mode can now be adapted to meet individual needs at the push of a button. There are three climate styles to select from: DIFFUSE, MEDIUM or FOCUS.

THERMATIC (standard). The THERMATIC automatic climate control system can control the temperature and ventilation for the driver and front passenger automatically. A solar sensor on the windscreen can record the intensity and direction of the sun's rays, for example. Further standard features include air recirculation, a cooled glove compartment and a combination filter which filters out particulate matter. There are two additional air outlets for the rear compartment on the rear end of the centre console.

Rear climate control (included with THERMOTRONIC automatic climate control system). The optional THERMOTRONIC automatic climate control system includes controls for the passengers in the rear seats: the airflow speed, airflow direction and temperature can be easily controlled at the push of a button, thus enhancing climate comfort for the rear occupants.



THERMATIC operates on the basis of sensor information including data for interior and exterior temperature as well as air humidity



The desired temperature and airflow can be set precisely using the separate controls in the rear

Seats

Seats that meet an exceptionally wide range of requirements in terms of seating comfort, ergonomic design and safety have been developed for the C-Class.



Seats. The seats in the C-Class are good news for the front and rear passengers, as they are exceptionally comfortable and provide plenty of legroom and shoulder room. The standard-fit driver's seat is partially power-adjustable and features manually adjustable lumbar support. Fully power-adjustable front seats are available as optional extras. Line-specific colour concepts, designs and fluting add attractive visual touches. The AVANTGARDE line is available with upholstery in the new cappuccino colour or fine sahara beige while the standard version impresses with the new black/blue combination. Further optional extras include 1/3 : 2/3 split-folding rear seats (standard for Estate).

Climatised seats for driver and front passenger (optional). The airflow for the climatised seats has been configured to ensure a well-balanced seat climate. There is a choice of three-stage seat heating and active ventilation for cooling the seats. The output of the climatised seats is reduced automatically after certain periods.



The ventilation and heating for the climatised seats can be adjusted separately

Memory package (optional). The front seats are available with full power adjustment as an optional extra. The switches for this are clearly arranged in the doors. If the Memory package is ordered, three position settings can be stored for the driver's seat, steering column and mirrors. Both front seats also feature 4-way lumbar support.



The Memory package remembers up to three positions for the driver's seat, steering column and exterior mirrors

Space

The C-Class Estate combines luxury and sportiness with generous interior space.



Fully folding down the rear seats allows a boot capacity of some 1500 litres with a practically flat load bay

Load compartment. The dimensions of the C-Class Estate – length 4.61 metres, width 1.77 metres and height 1.46 metres – form the basis for its load compartment. There's plenty of space for up to five people in the Estate – with even the rear seats offering passengers generous kneeroom. Fully folding down the rear bench seat gives a boot capacity of up to 1500 litres with a practically flat load bay. Convenient one-hand controls enable exceptionally easy 1/3 : 2/3 folding of the rear seats. The C-Class Estate sets another benchmark when it comes to payload, as it is capable of carrying up to 540 kilograms with ease. A stainless-steel cover on the boot sill helps prevent bumper and load compartment scratches or other damage when loading and unloading the car.

Load compartment cover (standard). A combined load compartment cover and net is positioned in the C-pillar area. The load compartment cover, colour-coded to match the interior appointments, shields luggage from the sun and prying eyes. For easy loading, it moves upwards automatically when the tailgate is opening and returns to its starting position when the tailgate is closed. Depending on the size of the load being carried, the safety net for dividing the load compartment can be attached between the B-pillars or the C-pillars. It helps protect the occupants from items in the load compartment. Further features in the load compartment enable items to be stowed tidily, e.g. two nets integrated in the side panelling for the practical stowage of smaller items, two retractable bag hooks, four load retainers and a 12-volt socket providing an additional power supply in the load compartment.



The rear bench seat can be split 2/3 with just one hand to give a versatile stowage space



The load compartment cover shields the contents of the boot from the sun's rays and prying eyes

Load compartment management

The C-Class Estate has plenty of stowage space. Intelligent solutions are required to enable it to be used efficiently – such as the EASY-PACK load compartment management system.



The load compartment rails in the EASY-PACK load-securing kit can help to secure the load

EASY-PACK load-securing kit (optional). The EASY-PACK load-securing kit consists of two load compartment rails, which are secured to the load compartment floor on the left and right and are used to hold load-securing elements. The telescopic bar included in the package allows the load compartment to be divided flexibly into different zones or bulky items to be secured. Bulky or round items can be secured to the load compartment sides using the retractable load-restraining belt. The four mounting elements also supplied and four load retainers already fitted as standard allow flexible use and easy handling for securing a wide range of luggage and cargo.

Self-levelling suspension (optional). The self-levelling rear suspension keeps the rear of the car at the specified level, even when the car is laden, and therefore has a positive effect on driving stability and driving safety – especially when towing a trailer. Another benefit for the occupants is a consistently high level of suspension comfort when the car is loaded within the permissible axle load limits.

EASY-PACK tailgate (optional). The EASY-PACK tailgate can be operated electro-mechanically for convenience. It can be opened at the push of a button from the driver's seat, at the tailgate or by using the ignition key. It can be closed again using a switch on the tailgate. In this case, it can also be stopped in a lower position. Furthermore, the tailgate can be made to open only as far as the roof edge by adjusting the setting on the instrument cluster. Independently of this, the tailgate can also be opened and closed manually using the release handle on the tailgate.



You can also open and close the EASY-PACK tailgate in a low position at the push of a button



C 63 AMG exterior

The expressive exterior of the C 63 AMG reflects its inner values perfectly: the sporty Saloon developing 336 kW features an AMG front and rear apron, side sill panels, and flared front wings. The updated look includes features such as the unique AMG LED daytime driving lights, the front apron with a high-gloss black cross-strut, the new radiator grille with a chrome louvre and the unique AMG bonnet with new powerdomes.

→ www.mercedes-amg.com

EXTERIOR

AMG 5-twin-spoke light-alloy wheels, painted titanium grey with a high-sheen finish, with 235/40 R 18 front tyres and 255/35 R 18 rear tyres

AMG bodystyling, consisting of front apron with side air outlets, side sill panels and diffuser-style rear apron

AMG high-performance braking system with 360 x 36 mm front brake discs and 330 x 26 mm rear brake discs

AMG spoiler lip on the boot lid (Saloon)

AMG sports exhaust system with two chromed twin tailpipes

Distinctive, flared front wings with "6.3 AMG" lettering

Tail lights with LED technology

Unique AMG bonnet with new powerdomes

Unique AMG front apron with cross strut in high-gloss black

Unique AMG LED daytime driving lights

Unique AMG radiator grille with a single chromed louvre





C 63 AMG interior

Inside, too, the C 63 AMG impresses with sporty touches throughout. At the heart of the interior is the new AMG tube-design instrument cluster with a colour display and the AMG Start-up indicator as well as the three-spoke AMG Performance steering wheel trimmed in nappa leather and featuring perforations in the grip area, silver-coloured aluminium shift paddles and flattened top and bottom sections. Exclusive, ergonomic AMG sports seats with ARTICO man-made leather/DINAMICA upholstery in black as standard (optionally available in single- or two-tone design leather) ensure excellent seating comfort. A black roof lining, dark brushed-aluminium trim and brushed stainless steel AMG door sill panels and AMG sports pedals complete the dynamic ambience.

INTERIOR

AMG door sill panels in brushed stainless steel

AMG instrument cluster, incl. RACETIMER and AMG Start-up indicator

AMG Performance steering wheel in nappa leather, with flattened top and bottom sections as well as silver-coloured aluminium gearshift paddles, incl. ATTENTION ASSIST

AMG speed-sensitive sports steering

AMG sports seats in ARTICO man-made leather/DINAMICA in black

New rotary switch for selecting the four transmission modes and the Race Start function

Brushed stainless-steel sports pedals with rubber studs

Dark brushed-aluminium trim



C 63 AMG technology

The AMG 6.3-litre V8 naturally aspirated engine and the AMG SPEEDSHIFT MCT 7-speed sports transmission offer an emotional driving feel and driving dynamics at the highest level. Yet when it comes to choosing a sporty or comfort-oriented driving style, the driver always has the final say in the sports saloon.

AMG 6.3-litre V8 engine. A high-revving naturally aspirated engine with thoroughbred motor-racing technology: the vertical arrangement of the intake and exhaust ducts as well as the magnesium variable-intake manifold with two integrated throttle valves ensure optimum charging of the eight cylinders. Further high-tech features include the variable camshaft adjustment, four valves per cylinder, the stiff aluminium crankcase and the low-friction TWAS (twin-wire-arc-spraying) coating used for the cylinder walls. The V8 powerplant develops 336 kW at 6800 rpm, delivering impressive pulling power and a torque of 600 Nm at 5000 rpm. Ideal ingredients for powerful acceleration in every engine speed range, as the driver has over 500 Nm on tap between 2000 and 6250 rpm. The AMG Performance package boosts the output by 22 kW to 358 kW, enabling the car to accelerate from 0 to 100 km/h in an impressive 4.4 s (4.5 s for Estate).

AMG sports suspension. The retuned AMG sports suspension delivers excitement thanks to increased agility, enhanced lateral acceleration potential and improved overall ride comfort. Together with the new AMG 5-twin-spoke light-alloy wheels with 235/40 R 18 front tyres and 255/35 R 18 rear tyres, the specific three-link front suspension with a wider track, the AMG speed-sensitive sports steering and the three-stage ESP®, it ensures superlative driving dynamics and thrilling driving enjoyment. The AMG speed-sensitive sports steering has an even more direct ratio and, therefore, offers greater steering precision at high cornering speeds. The AMG sport suspension's stiff springs and gas-pressure shock absorbers ensure optimum road feel and minimise body movements. The AMG sports suspension therefore combines driving dynamics at the highest level with hallmark Mercedes long-distance comfort – and thus displays the characteristic attributes of a true AMG. The Electronic Stability Program ESP® has been specially adapted in line with the high level of driving dynamics, as it allows the driver to select the level of assistance provided by the dynamic handling control system by choosing one of three different control settings: ON, SPORT or OFF. The

activated setting is shown on the AMG instrument cluster's central display. The AMG high-performance braking system featuring large, internally ventilated and perforated brake discs ensures good levels of deceleration and fade resistance. Not to mention perfect brake control and short stopping distances.

AMG SPEEDSHIFT MCT 7-speed sports transmission.

Equipped with AMG aluminium steering-wheel shift paddles, four modes and a Race Start function, the new 7-speed automatic transmission delivers enhanced driving dynamics, higher efficiency and 10 percent lower fuel consumption than the predecessor model. The Race Start function allows the driver to call up the maximum acceleration potential with optimum traction. The “S” (Sport), “S+” (Sport Plus), “C” (Comfort) and “M” (Manual) modes each have different gear-change characteristics and speeds: gear changes in “S” and “S+” modes are around 20 or 40 percent quicker than in “C” mode respectively - while in “M” mode gear changes take just 100 milliseconds, making them some 50 percent faster. A push of a button activates the desired driving mode: distinctly sporty or more comfort-oriented. There is also an automatic double-declutching function when downshifting, which provides an emotional sound experience as well as reducing power-off effects. This function has a positive effect when braking on the approach to bends in particular.



The AMG SPEEDSHIFT MCT 7-speed sports transmission offers customised modes for maximum driving pleasure



Motor-racing technology gives the AMG 6.3-litre V8 engine maximum agility



AMG Performance Studio

The AMG Performance Studio offers a range of options for further enhancing the dynamic aspects of the C 63 AMG. A prime example of this is the AMG Performance package, which boosts the output by 22 kW to 358 kW and also includes a variable intake manifold painted in titanium grey, the AMG high-performance composite brake system with compound front brake discs, red-painted brake calipers, the AMG carbon-fibre spoiler lip on the boot lid, and the AMG Performance steering wheel in nappa leather/Alcantara®.

Options available separately include AMG carbon-fibre trim, the AMG Exterior Carbon-Fibre package, AMG door sill panels with white LED illumination and the AMG rear-axle differential lock. AMG multi-spoke light-alloy wheels in titanium grey or matt black, or 5-spoke light-alloy wheels in titanium grey, also available as optional extras, emphasise the unique appearance of the C 63 AMG.

The AMG Driver's package allows an electronically governed top speed of 280 km/h and includes participation in driving training at the AMG Driving Academy. What's more, the AMG Performance Studio can meet customer requests for personalised vehicles as well as special one-off models.





Standard equipment

When it comes to standard equipment, the C-Class impresses with an array of key comfort- and safety-related features. Not to mention high-quality visual attributes such as LED tail lights, a chromed radiator grille and a harmonious interior.



EXTERIOR

7-spoke light-alloy wheels with 195/60 R 16 tyres (not for Estate) or 205/55 R 16 tyres (depending on engine version)

Beltline trim strip in matt black

Bumpers and side trim in vehicle colour

LED tail lights

Louvred radiator, chromed, star on bonnet

Roof rails in black (Estate only)

INTERIOR

Black backplate

Brighton fabric upholstery

Door openers with silver-chrome surface

High-gloss black piano-lacquer-look trim

Multifunction steering wheel and shift/selecter lever in nappa leather

Seat design with large panels and horizontal seamlines





The upholstery is available in Brighton fabric as standard or ARTICO man-made leather as an option. There are also four upholstery colours to choose from (two in the case of ARTICO man-made leather), with the same upholstery being used for the inside of the doors in each case. The remainder of the interior is in elegant black, while the trim has a fine piano-lacquer-look finish.

BLACK

- 021 Brighton fabric
 - 121 ARTICO man-made leather (optional)
-

ALPACA GREY

- 028 Brighton fabric
 - 128 ARTICO man-made leather (optional)
-

BLACK/BLUE

- 062 Brighton fabric
-

BLACK/BEIGE

- 065 Brighton fabric
-

TRIM

- H80 High-gloss black piano-lacquer look
 - 734 Eucalyptus wood (optional)
-

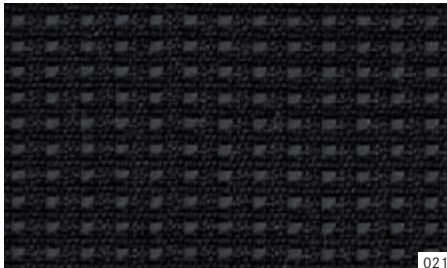

021

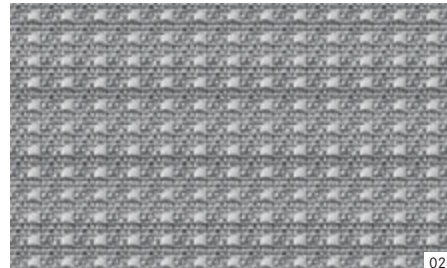

028

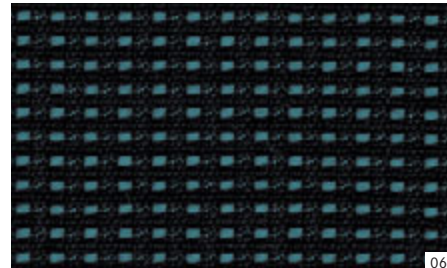

062



065

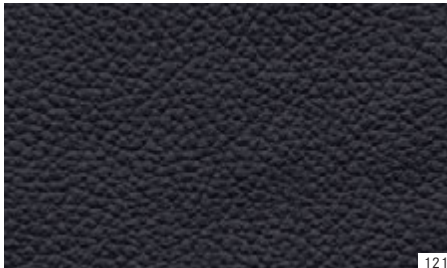

121

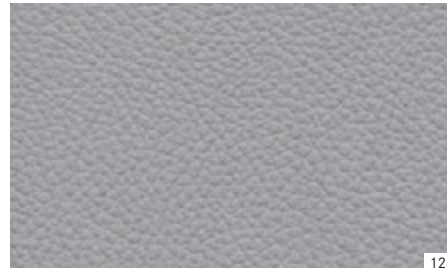

128

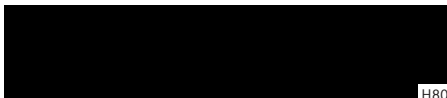

H80

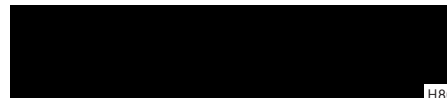

H80

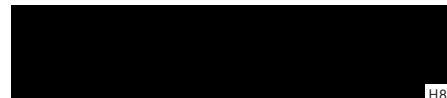

H80

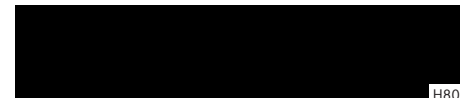

H80



734



734



734



734



ELEGANCE line

The optional ELEGANCE line emphasises the elegant side of the C-Class. Exterior features that catch the eye right away include the polished chrome highlights, while the harmonious interior features an impressive mix of fine trim and a discreet tone-in-tone colour concept.

EXTERIOR

7-twin-spoke light-alloy wheels with 205/55 R 16 or 225/45 R 17 tyres (depending on engine version)

Ambient lighting integrated in exterior mirror housings

Beltline trim strip in polished aluminium

Chrome trim strips on sides and on rear bumper

Louvred radiator with high-gloss paint finish and chrome highlights, star on the bonnet

Roof rails in aluminium (Estate only)

INTERIOR

ATTENTION ASSIST

Backplate in cream

Colour display (11.4 cm) in the instrument cluster

Door openers with silver-chrome surface

Front ambient lighting in the doors/Light package

Luxury multifunction steering wheel with silver shadow trim

Matt brown ash trim

NECK-PRO luxury head restraints for the front seats

Newcastle fabric upholstery

Seat design with vertical seamlines

Steering wheel and shift/selector lever in nappa leather with chrome insert





The fabric, ARTICO man-made-leather and leather upholstery can be specified in black, almond beige or alpaca grey and combined with a fine-grained matt brown ash wood trim. The dashboard, inside of the doors and carpets match the selected interior colour perfectly.

BLACK

- 421 Newcastle fabric
- 121 ARTICO man-made leather (optional)
- 221 Leather (optional)

ALMOND BEIGE

- 425 Newcastle fabric
- 125 ARTICO man-made leather (optional)
- 225 Leather (optional)

ALPACA GREY

- 428 Newcastle fabric
- 128 ARTICO man-made leather (optional)
- 228 Leather (optional)

TRIM

- H06 Matt brown ash wood
 - 731 Brown burr walnut wood (optional)
-



421

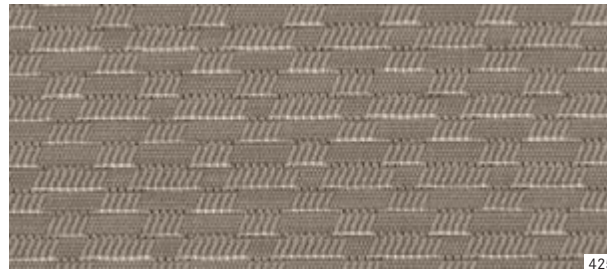

425

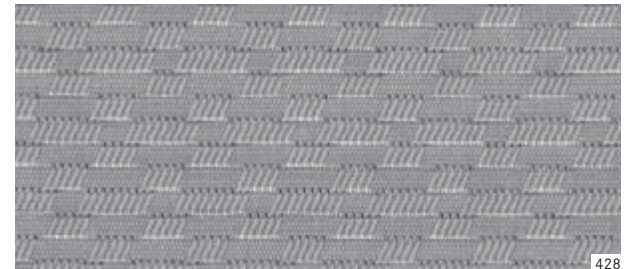

428



121
221

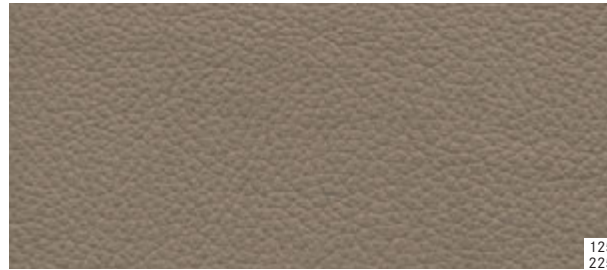

125
225



128
228



H06



H06



H06



731



731



731



AVANTGARDE line

The optional AVANTGARDE line lends the C-Class a distinctly sporty character. The exterior is more dynamic, more striking and bolder, while colour contrasts in the interior add dynamic touches.

EXTERIOR

5-twin-spoke light-alloy wheels with 225/45 R 17 tyres

Ambient lighting integrated in exterior mirror housings

Beltline trim strip in polished aluminium

Chrome trim strips on sides and on rear bumper

Louvred radiator in matt brilliant silver, with chrome highlights and integrated star

Roof rails in aluminium (Estate only)

INTERIOR

ARTICO man-made leather/Liverpool fabric upholstery

ATTENTION ASSIST

Brushed aluminium trim

Colour display (11.4 cm) in the instrument cluster

Door openers with silver-chrome surface

Front ambient lighting in the doors/Light package

Seat design with horizontal seamlines

Shift/selecter lever in nappa leather with chrome insert

Sports steering wheel (12-button) in nappa leather, perforated grip area, matt silver-look trim, silver backplate





The upholstery is trimmed in a combination of ARTICO man-made leather and Liverpool fabric as standard or in genuine leather as an option. The high-quality interior is trimmed in the selected colour. The brushed aluminium trim, specified as standard, emphasises the sporty ambience.

BLACK/BLACK

721 ARTICO man-made leather/Liverpool fabric
221 Leather (optional)

BLACK/ALPACA GREY

728 ARTICO man-made leather/Liverpool fabric
228 Leather (optional)

BLACK/CAPPUCCINO

224 Leather (optional)

BLACK/SAHARA BEIGE

235 Leather (optional)

TRIM

739 Brushed aluminium
736 Black ash wood (optional)



721

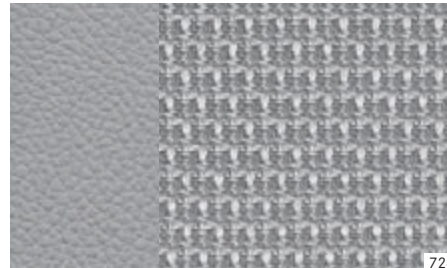

728

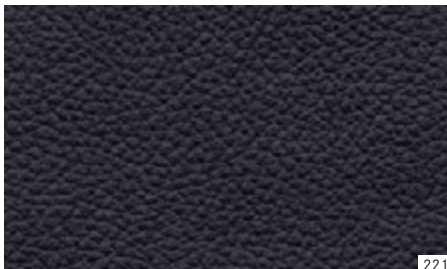

221

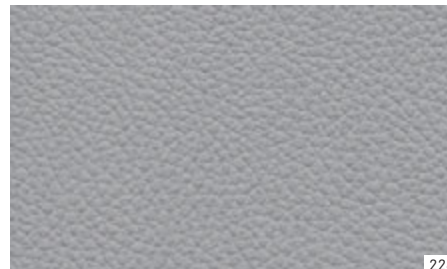

228

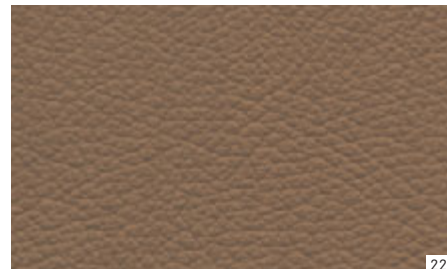

224



235



739



739



739



739



736



736



736



736



AMG Sports package

The dynamic appearance of the C-Class can be further enhanced by adding the optional AMG Sports package. The exciting and distinctive AMG bodystyling consists of the front apron, side sill panels and rear apron. AMG light-alloy wheels featuring new 5-twin-spoke styling, a high-sheen finish and mixed-size tyres (front 225/45 R 17 and rear 245/40 R 17) as well as sports suspension lowered by 15 millimetres complete the sporty look.

EXTERIOR

AMG 5-twin-spoke light-alloy wheels with a high-sheen finish, with 225/45 R 17 front tyres and 245/40 R 17 rear tyres

AMG bodystyling comprising front apron, side sill panels and rear apron

Fog lamps and daytime driving lights, double-round design with chrome surround

Lowered sports suspension

Perforated front brake discs, brake calipers with "Mercedes-Benz" lettering

Polished stainless-steel exhaust tailpipe trim

Speed-sensitive sports steering





A true AMG when it comes to inner values, too: exciting features which catch the eye immediately include front sports seats, a new 3-spoke multifunction sports steering wheel in nappa leather with a flattened bottom section and gearshift paddles (when fitted in conjunction with an automatic transmission), and an aluminium-look shift/selecter lever with a leather gaiter. The look of the instrument cluster is based on the tube-type design found in the C 63 AMG. Brushed stainless-steel sports pedals, black floor mats with AMG lettering and a black roof lining are further highlights of the sporty interior.

INTERIOR

3-spoke multifunction sports steering wheel in nappa leather, with flattened bottom section, incl. ATTENTION ASSIST

Brushed stainless-steel sports pedals with rubber studs

Floor mats in black with AMG lettering

Front sports seats with ARTICO man-made leather/Liverpool fabric upholstery in black or alpaca grey, optionally available in leather with additional colour combinations

Roof lining in black

Shift/selecter lever in aluminium look with leather gaiter

Steering-wheel shift paddles and manual shift mode (M) in conjunction with automatic transmission





designo



The exclusive designo two-tone leather appointments are available in several combinations – designo porcelain/black, designo sand/black or designo classic red/black – for both the Saloon and the Estate. In addition to the seats in the characteristic two-tone design, the door centre panels and the armrests in the doors are trimmed in designo leather – as is the armrest in the centre console in the C 63 AMG. The appointments are completed by the fabric roof lining in black and the velour floor mats with edging in designo black leather (not for C 63 AMG).



The high-quality designo interior can be further enhanced by adding the extended appointments in designo black leather, including the upper section of the dashboard and the beltlines on the doors. Furthermore, a new AMG carbon fibre/piano-lacquer-look trim in high-gloss black is available as an optional extra. In addition, the interior of the new C 63 AMG comes with the option of exclusive designo single-tone leather upholstery in black, sand, porcelain or classic red, giving discerning customers further options for making the car even more individual and exclusive.

Standard equipment | Selection



Audio 20 CD



THERMATIC automatic climate control



Standard steering wheel in nappa leather



Roof rails in black (for Estate only)



Door sill panel



Split rear bench seat (for Estate only)



LED tail light



Load compartment cover (for Estate only)

Optional extras | Selection



Panoramic sliding sunroof



Sliding sunroof



Convenience Telephony



Becker® MAP PILOT



EASY-PACK tailgate (for Estate only)



ATTENTION ASSIST



Trailer coupling



COMAND Online

Wheels



7-spoke light-alloy wheels with 195/60 R 16 tyres (Saloon, standard for C 180 CDI BlueEFFICIENCY, C 200 CDI BlueEFFICIENCY, C 180 BlueEFFICIENCY, Code R20)



7-twin-spoke light-alloy wheels with 205/55 R 16 tyres (standard for 4-cylinder ELEGANCE models, Code R27)



5-twin-spoke light-alloy wheels with 225/45 R 17 tyres (standard for AVANTGARDE models, Code 44R)



5-twin-spoke light-alloy wheels with 225/45 R 17 front tyres and 245/40 R 17 rear tyres (optional, Code R52)



7-spoke light-alloy wheels with 205/55 R 16 tyres (standard for 4-cylinder Saloon models from C 220 CDI BlueEFFICIENCY or C 200 BlueEFFICIENCY upwards, standard for 4-cylinder Estate models, Code R75)



7-twin-spoke light-alloy wheels with 225/45 R 17 tyres (standard for 6-cylinder ELEGANCE models, optional for 4-cylinder models, Code 26R)



Multi-spoke light-alloy wheels with 225/50 R 16 tyres (optional for 4-cylinder models, Code 43R)



5-twin-spoke light-alloy wheels with 225/45 R 17 front tyres and 245/40 R 17 rear tyres (optional, Code R95)



5-twin-spoke AMG light-alloy wheels with 225/45 R 17 front tyres and 245/40 R 17 rear tyres, with high-sheen finish (part of the optional AMG Sports package, not for C 63 AMG, Code 784)



5-twin-spoke AMG light-alloy wheels with 225/40 R 18 front tyres and 255/35 R 18 rear tyres, with high-sheen finish (optional, not for C 63 AMG, Code 786)



5-spoke AMG light-alloy wheels with 235/40 R 18 front tyres and 255/35 R 18 rear tyres, painted titanium grey with high-sheen finish (optional for C 63 AMG, Code 790)



Multi-spoke AMG light-alloy wheels with 235/35 R 19 front tyres and 255/30 R 19 rear tyres, painted matt black with high-sheen finish (optional for C 63 AMG, Code 797)



7-spoke AMG light-alloy wheels with 225/40 R 18 front tyres and 255/35 R 18 rear tyres, with high-sheen finish (optional, not for C 63 AMG, Code 782)



5-twin-spoke AMG light-alloy wheels with 235/40 R 18 front tyres and 255/35 R 18 rear tyres, painted titanium grey with high-sheen finish (standard for C 63 AMG, Code 795)



Multi-spoke AMG light-alloy wheels with 235/35 R 19 front tyres and 255/30 R 19 rear tyres, painted titanium grey with high-sheen finish (optional for C 63 AMG, Code 788)



incenio 5-twin-spoke light-alloy wheels with 225/40 R 18 tyres at the front and 255/35 R 18 tyres at the rear (accessory)



Surf the web, watch movies, listen to music: the iPad® docking station for the rear compartment delivers entertainment on the move

Genuine accessories

A Mercedes-Benz is more than just a car. It can be a travel companion, an office, a living space. And this diversity is reflected in the Mercedes-Benz accessories range.

The innovative iPad® docking station for the rear compartment allows the tablet computer to be integrated into the rear of the C-Class and charges its battery at the same time. All the entertainment content stored on the iPad® can be used while travelling. And if the car is also equipped with the InCar Hotspot, even an iPad® not equipped with UMTS has full internet access.

Discover the full range of incenio light-alloy wheels available in the genuine accessories range. Elegant or sporty, distinctive or dynamic – they allow you to give the C-Class

the perfect finishing touch to reflect your tastes. For example, there are the incenio “Proserpina” light-alloy wheels for tyre sizes 225/45 R 17 (front) and 245/40 R 17 (rear).

The KidFix child seat is ideal for children aged between around 3½ and 12 years (15 to 36 kg). The raised seat and height-adjustable backrest can provide optimum side impact protection.

One particularly important aspect is the correct transport of bulky objects such as bicycles, skis or large items of

luggage. There is a range of safe and flexible rack systems available for such tasks. The basic carrier bars developed specifically for the C-Class can be combined with a number of different roof-rack systems such as the ski and snowboard rack, the bicycle rack or the Mercedes-Benz roof boxes, which hold around 330 or 450 litres and can be opened on both sides. Please consult our special brochures or your Mercedes-Benz dealer for further details on the extensive range of genuine accessories.



“Proserpina” 5-spoke light-alloy wheels with 225/45 R 17 tyres at the front and 245/40 R 17 tyres at the rear. Further wheels available on request



The KidFix child seat provides an exceptional level of safety for younger passengers



The roof box is an elegant solution for stowing all manner of sports or leisure equipment from diving gear to snowboards

Services

Mercedes-Benz Museum. 125 years of automotive history in one place – this is what awaits you at the Mercedes-Benz Museum in Stuttgart. Experience the unique excitement, and embark upon a thrilling journey through time. Housed inside an architecturally impressive building, over 1500 exhibits on nine levels give you an insight into the unique tradition and powers of innovation of the Mercedes-Benz brand. See the world's first two automobiles in the shape of the Benz Patent-Motorwagen (motor car) and the Daimler motorised carriage – both from the year 1886. Two linked circuits take you from the beginnings of the automobile, past a series of unforgettable classics and on to a glimpse of what the future holds – in an area covering a total of 16,500 square metres. Enjoy the unique brand experience. We look forward to your visit. Further details can be found at www.mercedes-benz-classic.com/museum

MercedesCard. The card is your ticket to the Mercedes-Benz experience. Four times a year, we will send you the Mercedes Magazine, featuring fascinating reports from the world of Mercedes-Benz and articles about our latest vehicles. A MercedesCard also has many other uses too. As a VISA credit card, it is an internationally accepted means of payment. Further benefits are available to provide you with peace of mind, such as insurance packages for your Mercedes and other insurance services for the whole family. You also get free entry to the Mercedes-Benz Museum simply by showing your VISA MercedesCard. Further details can be found at www.mercedes-benz.de/mercedescard

Mercedes-Benz Financial Services. Mercedes-Benz stands for quality, innovation and safety – and the same applies to Mercedes-Benz Financial Services. Our innovative leasing and financing products are tailored to your financial needs and means, making it easy for you to secure the keys to your dream car. Once you are on the road, our insurance products offer you comprehensive protection on every trip. Finally, our service products ensure that your car is always in tip-top condition whilst keeping costs transparent and easily manageable. For a detailed quotation, please contact your Mercedes-Benz dealer, who will be glad to go through the latest financial services and terms and conditions with you.

Mercedes-Benz mobility. Your new car comes complete with the promise of feeling safe on the road, but if you should ever need assistance, then Mercedes-Benz Service24h is there to help. Just call the freephone service hotline on 00800 1 777 7777². The newly integrated telematics service, Mercedes-Benz Contact³, is even more customer friendly: a touch of a button is all it takes to contact the Mercedes-Benz customer centre. If you wish, the relevant vehicle and position-related data can be transmitted at the same time, thereby allowing the centre to react quickly and provide rapid on-the-spot assistance. Also standard with your new car at no extra charge is the Mercedes-Benz Mobilo⁴ mobility package. Whether you have lost your key, had a breakdown which cannot be repaired immediately or suffered damage to the vehicle due to an accident or vandalism, Mobilo is there to help you reach your destination – anywhere in Europe. Whatever your problem, one thing is certain: you will soon be able to resume your journey.

Service packages. Vehicle-specific services allow you to put together an individual package for your Mercedes, including long-term protection against unforeseeable repair costs and high-quality servicing with genuine Mercedes-Benz parts. You can also count on the extensive network of Mercedes-Benz workshops, where you will receive the usual high standard of service for your Mercedes at a predictable, fixed price. Please ask your Mercedes-Benz dealer for further details.

Test drive. The unique feeling of driving a Mercedes cannot be put into words. Which is why we'd like to invite you to experience it for yourself. Take a test drive and find out first hand how it feels to drive your dream car. Simply visit www.mercedes-benz.com to locate the nearest Mercedes-Benz dealer in your country or region.

Interactive Owner's Manual. The website also offers an interactive tour, enabling you to take a closer look at your desired model. These informative clips are the ideal way to acquaint yourself with your dream car. You can view key functions in detail, gain an insight into the car's inner workings or look at the benefits of each model. For further details, go to:
www.mercedes-benz.de/owners-manual

Mobile internet. Now you can access the entire world of Mercedes-Benz from your mobile phone. As well as an overview of all the passenger car models, there are insights into the entire brand world along with a wealth of entertainment offers and direct links to our range of services at www.mercedes.mobi

¹ Information about the MercedesCard in Austria and Switzerland can be found on the Mercedes-Benz websites for these countries ² Alternative: +49 69 95 30 72 77 ³ Requires a factory-fitted radio, connected to an operational mobile phone

⁴ Once the warranty has expired, Mobilo can be extended in periods of one year for a maximum of 30 years, provided that regular maintenance is carried out by your Mercedes-Benz service partner

Dimensions of Saloon

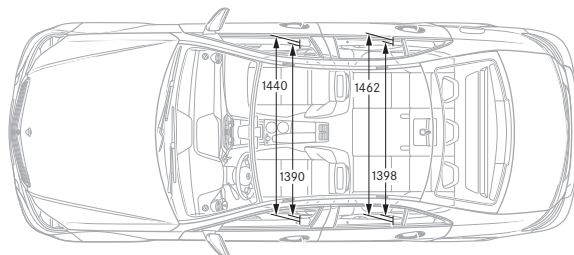
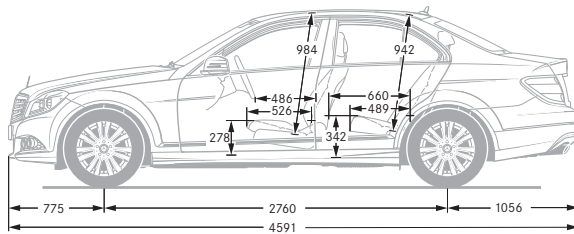
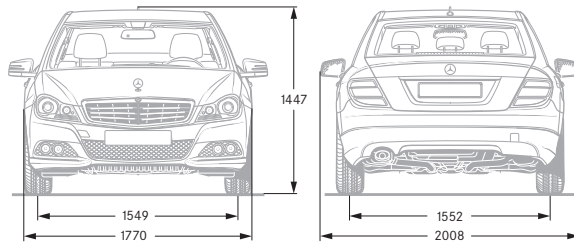

Dimensions of Estate

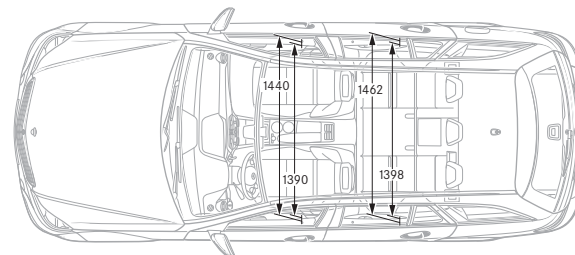
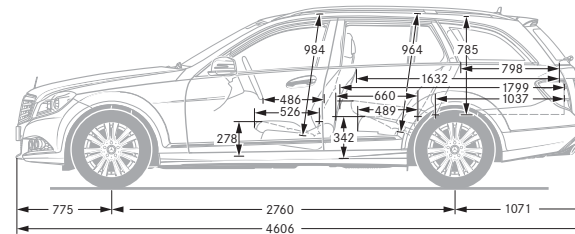
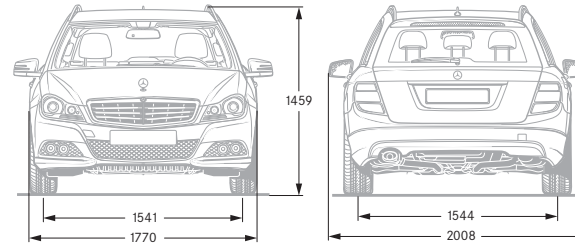

Paintwork

The innovative paint system developed by Mercedes-Benz includes one of the best clearcoats on the automotive market and is a key factor behind the car's excellent value retention. The secret lies in the exceptionally dense molecular structure, which makes both the metallic and the non-metallic clearcoats more resistant and produces a longer-lasting and visibly more intensive shine.

NON-METALLIC PAINTS (standard)

- 040 black
- 590 fire opal
- 650 calcite white

METALLIC PAINTS (optional)

- 183 magnetite black
- 197 obsidian black
- 497 cuprite brown
- 775 iridium silver
- 792 palladium silver
- 794 pearl beige
- 890 cavansite blue

SPECIAL METALLIC PAINTS (optional)

- 779 alabandite grey
- 799 diamond white BRIGHT

Technical data for Saloon

	C 180 CDI BlueEFFICIENCY	C 200 CDI BlueEFFICIENCY	C 220 CDI BlueEFFICIENCY	C 250 CDI BlueEFFICIENCY	C 250 CDI 4MATIC BlueEFFICIENCY	C 300 CDI 4MATIC BlueEFFICIENCY	C 350 CDI BlueEFFICIENCY
DIESEL ENGINES							
Total displacement (cc)	2143	2143	2143	2143	2143	2987	2987
Rated output ¹ (kW at rpm)	88/2800-4600	100/2800-4600	125/3000-4200	150/4200	150/4200	170/3800	195/3800
Accel. 0-100 km/h (s)	10.5 (10.8)	9.2 (9.1)	8.4 (8.1)	7.0 (7.1)	- (7.1)	- (6.4)	- (6.0)
Top speed, approx. (km/h)	208 (206)	218 (215)	232 (231)	240 (240)	- (240)	- (250) ³	- (250) ³
Fuel consumption ² (l/100 km)							
Urban	5.9-6.3 (6.1-6.4)	5.9-6.3 (6.1-6.4)	5.6-6.3 (6.0-6.4)	6.1-6.7 (6.0-6.4)	- (6.7-6.9)	- (9.1-9.2)	- (7.2)
Extra-urban	4.1-4.7 (4.3-4.7)	4.1-4.7 (4.3-4.7)	3.7-4.3 (4.1-4.5)	4.0-4.5 (4.1-4.5)	- (4.6-5.0)	- (5.9-6.1)	- (5.2-5.3)
Combined	4.8-5.3 (4.9-5.3)	4.8-5.3 (4.9-5.3)	4.4-5.1 (4.8-5.2)	4.8-5.3 (4.8-5.2)	- (5.4-5.7)	- (7.0-7.2)	- (5.9-6.0)
CO ₂ emissions ² (g/km) comb.	125-139 (129-140)	125-139 (129-140)	117-133 (125-136)	125-140 (125-136)	- (144-152)	- (185-189)	- (154-157)
Emissions standard	Euro 5	Euro 5	Euro 5	Euro 5	Euro 5	Euro 5	Euro 5

	C 180 BlueEFFICIENCY	C 200 BlueEFFICIENCY	C 250 BlueEFFICIENCY	C 350 BlueEFFICIENCY	C 350 4MATIC BlueEFFICIENCY	C 63 AMG
PETROL ENGINES						
Total displacement (cc)	1796	1796	1796	3498	3498	6208
Rated output ¹ (kW at rpm)	115/5000	135/5250	150/5500	225/6500	225/6500	336/6800
Accel. 0-100 km/h (s)	9.0 (8.9)	8.2 (7.8)	- (7.2)	- (6.0)	- (6.0)	- (4.5)
Top speed, approx. (km/h)	225 (223)	237 (235)	- (240)	- (250) ³	- (250) ³	- (250) ³
Fuel consumption ² (l/100 km)						
Urban	9.3-9.6 (8.7-8.9)	9.3-9.8 (8.7-9.0)	- (8.7-9.0)	- (9.4-9.6)	- (10.0-10.1)	- (18.1)
Extra-urban	5.2-5.9 (5.0-5.7)	5.2-5.8 (5.1-5.6)	- (5.1-5.6)	- (5.3-5.6)	- (5.9-6.1)	- (8.5)
Combined	6.7-7.3 (6.4-6.9)	6.6-7.2 (6.4-6.9)	- (6.4-6.9)	- (6.8-7.0)	- (7.4-7.6)	- (12.0)
CO ₂ emissions ² (g/km) comb.	157-169 (148-160)	154-168 (150-161)	- (150-161)	- (159-164)	- (174-178)	- (280)
Emissions standard	Euro 5	Euro 5	Euro 5	Euro 5	Euro 5	Euro 5

¹ Figures in accordance with Directive 80/1269/EEC in the currently applicable version ² The figures shown were obtained in accordance with the prescribed measuring process (Directive 80/1268/EEC in the currently applicable version). The figures are not based on an individual model and do not constitute part of the product offer; they are provided solely for purposes of comparison between different vehicle models ³ Electronically governed
 Figures in brackets apply to vehicles with automatic transmission. Further technical data can be found at www.mercedes-benz.com

Technical data for Estate

	C 180 CDI BlueEFFICIENCY	C 200 CDI BlueEFFICIENCY	C 220 CDI BlueEFFICIENCY	C 250 CDI BlueEFFICIENCY	C 250 CDI 4MATIC BlueEFFICIENCY	C 300 CDI 4MATIC BlueEFFICIENCY	C 350 CDI BlueEFFICIENCY
DIESEL ENGINES							
Total displacement (cc)	2143	2143	2143	2143	2143	2987	2987
Rated output ¹ (kW at rpm)	88/2800-4600	100/2800-4600	125/3000-4200	150/4200	150/4200	170/3800	195/3800
Accel. 0-100 km/h (s)	10.8 (11.1)	9.6 (9.5)	8.5 (8.3)	7.3 (7.4)	- (7.4)	- (6.5)	- (6.3)
Top speed, approx. (km/h)	201 (200)	209 (207)	219 (219)	238 (237)	- (237)	- (242)	- (250) ³
Fuel consumption ² (l/100 km)							
Urban	6.0-6.4 (6.2-6.5)	6.0-6.4 (6.2-6.5)	6.0-6.3 (6.3-6.4)	6.3-6.7 (6.3-6.4)	- (6.7-6.9)	- (9.2-9.3)	- (7.3-7.4)
Extra-urban	4.1-4.8 (4.5-4.9)	4.1-4.8 (4.5-4.9)	4.0-4.5 (4.3-4.6)	4.1-4.6 (4.3-4.6)	- (4.8-5.1)	- (6.0-6.4)	- (5.4)
Combined	4.8-5.4 (5.1-5.5)	4.8-5.4 (5.1-5.5)	4.7-5.2 (5.1-5.3)	4.9-5.4 (5.1-5.3)	- (5.5-5.8)	- (7.2-7.4)	- (6.0-6.2)
CO ₂ emissions ² (g/km) comb.	127-141 (134-144)	127-141 (134-144)	124-135 (134-138)	128-141 (134-138)	- (147-155)	- (191-195)	- (159-162)
Emissions standard	Euro 5	Euro 5	Euro 5	Euro 5	Euro 5	Euro 5	Euro 5

	C 180 BlueEFFICIENCY	C 200 BlueEFFICIENCY	C 250 BlueEFFICIENCY	C 350 BlueEFFICIENCY	C 63 AMG
PETROL ENGINES					
Total displacement (cc)	1796	1796	1796	3498	6208
Rated output ¹ (kW at rpm)	115/5000	135/5250	150/5500	225/6500	336/6800
Accel. 0-100 km/h (s)	9.2 (9.1)	8.4 (8.1)	- (7.4)	- (6.1)	- (4.6)
Top speed, approx. (km/h)	218 (216)	228 (226)	- (233)	- (250) ³	- (250) ³
Fuel consumption ² (l/100 km)					
Urban	9.3-9.9 (8.7-9.0)	9.6-10.2 (8.9-9.1)	- (8.9-9.1)	- (9.7-9.9)	- (18.6)
Extra-urban	5.4-6.1 (5.4-5.8)	5.5-6.2 (5.4-5.7)	- (5.4-5.7)	- (5.6-5.8)	- (8.7)
Combined	6.8-7.5 (6.6-7.0)	6.9-7.6 (6.7-6.9)	- (6.7-6.9)	- (7.1-7.3)	- (12.3)
CO ₂ emissions ² (g/km) comb.	160-176 (155-163)	160-177 (155-162)	- (155-162)	- (165-170)	- (288)
Emissions standard	Euro 5	Euro 5	Euro 5	Euro 5	Euro 5

¹ Figures in accordance with Directive 80/1269/EEC in the currently applicable version ² The figures shown were obtained in accordance with the prescribed measuring process (Directive 80/1268/EEC in the currently applicable version). The figures are not based on an individual model and do not constitute part of the product offer; they are provided solely for purposes of comparison between different vehicle models ³ Electronically governed
 Figures in brackets apply to vehicles with automatic transmission. Further technical data can be found at www.mercedes-benz.com

NON-METALLIC PAINTS



METALLIC PAINTS

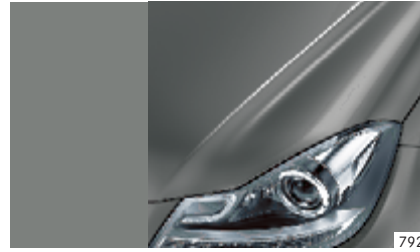

SPECIAL METALLIC PAINTS

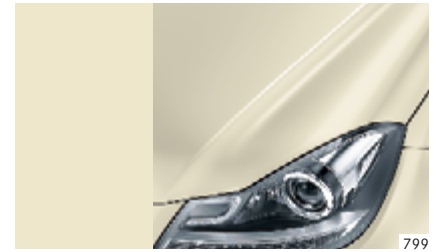

Take-back of end-of-life vehicles. Coming full circle. At the end of its long life, you can return your C-Class to us for environment-friendly disposal in accordance with the EU End-Of-Life Vehicle Directive¹. But that day lies a long way off.

¹ Applies in accordance with national regulations to vehicles up to 3.5 tonnes gross weight. Mercedes-Benz passenger cars have met the statutory regulations governing the suitability of their design for reuse and recycling for a number of years now. A network of vehicle take-back depots and dismantlers has been established which will process your vehicle in an environment-friendly manner. The ways in which both vehicles and parts can be recovered are subject to ongoing development and improvement. Consequently, the C-Class will be able to comply with any future increases in the recycling quota within the stipulated time limits. For further information:

www.mercedes-benz.com

Please note: changes may have been made to the product since this brochure went to press (04.02.2011). The manufacturer reserves the right to make changes to the design, form, colour and specification during the delivery period, provided these changes, while taking into account the interests of the vendor, can be deemed reasonable with respect to the purchaser. Where the vendor or the manufacturer uses symbols or numbers to describe an order or the subject of an order, no rights may be derived solely from these. The illustrations may show accessories and items of optional equipment which are not part of standard specification. Colours may differ slightly from those shown in the brochure, owing to the limitations of the printing process. This brochure is distributed internationally. It provides a general indication of the range of models, features, optional extras, colours and/or services available in various countries. Some of the models, features, optional extras, colours and/or services shown may not be available in your country or may only be available in a different specification. Additionally some models, features, optional extras, colours and/or services may only be available in combination with others. For current and more specific information in relation to the range of models, features, optional extras, colours and/or services available in your country, and their pricing, you should contact your nearest authorised Mercedes-Benz Passenger Car Dealer.

www.mercedes-benz.com