

The C-Class Coupé



Mercedes-Benz

power. Even the 4-cylinder models now come with the option of the 7G-TRONIC PLUS automatic transmission. The low silhouette with a long, arrow-shaped bonnet. The upright, louvred radiator grille with a central star, the classic Opel design: built for people who don't like to stand still. Contemporary driving requires intelligent drive systems. Additional fuel-saving potential comes courtesy of the standard-fit ECO mode. The car goes a little bit further ahead than you think. Thanks to numerous safety systems which include the automatic emergency braking control system, which has the ability to apply the brakes in anticipation of danger. How do you make something unique even more unique? The list of equipment is a good place to start. The interior offers a leather look. The only things more individual than the interior are the places to visit. The 4-cylinder models now come with the option of the 7G-TRONIC PLUS automatic transmission. The low silhouette with a long, arrow-shaped bonnet. The upright, louvred radiator grille with a central star, the classic Opel design: built for people who don't like to stand still. **More style per hour.** Contemporary driving requires intelligent drive systems. Additional fuel-saving potential comes courtesy of the standard-fit ECO mode.



The new C-Class Coupé embodies the excitement between style and drive. A forwards thrusting, dynamic coupé that you never tire of looking at on the outside. A place to lean back and savour each bend on the inside – supreme sportiness and consummate practicality. Not to mention the sheer driving pleasure in between. Backed by new, powerful

engines with standard-fit ECO start/stop function, sports-tuned AGILITY CONTROL suspension with selective damping system, an electronic brake-control system and benchmark-setting safety.

At a glance | from page 4 Insight | from page 22

The C-Class Coupé

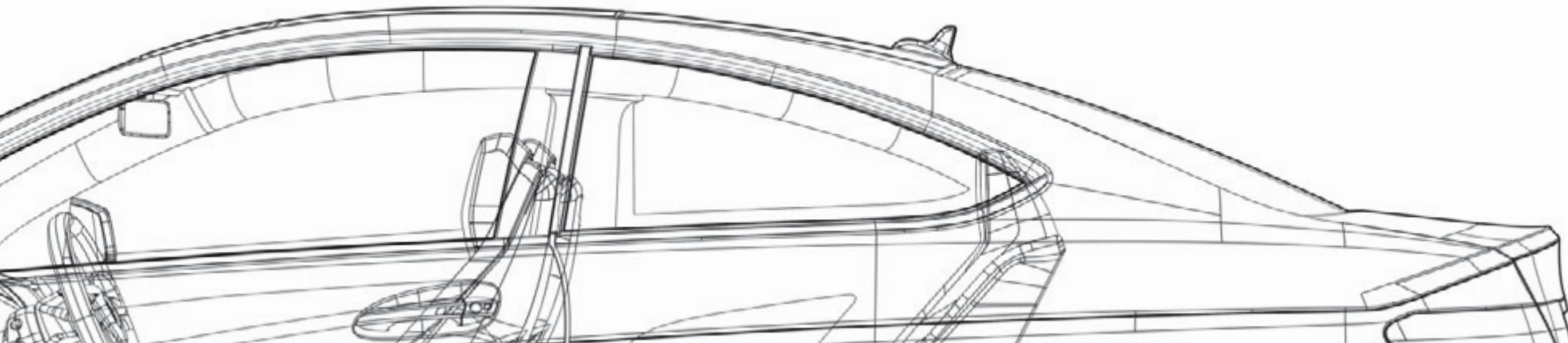

Stylish agility: BlueEFFICIENCY, diesel and petrol engines, transmissions and chassis.

Drive system & chassis | from page 28

Reassuring safety: the latest safety systems for the “Safe driving”, “In the event of danger” and “In an accident” phases.

Safety | from page 36

Entertaining relaxation: multimedia and assistance systems, interior appointments.

Comfort | from page 40

Sporty agility: the flagship C 63 AMG Coupé with 6.3-litre naturally aspirated engine.

AMG | from page 46

Desirable versatility: standard equipment and optional extras, packages, light-alloy wheels and accessories.

Equipment & appointments | from page 54

Exciting professionalism: everything about the Mercedes-Benz Museum, MercedesCard, Mercedes-Benz Financial Services, Mercedes-Benz mobility, service packages, test drive, Interactive Owner’s Manual and mobile internet.

Services | from page 72

Detailed listings: technical data, dimensions and paintwork.

Facts & colours | from page 74



A silver Mercedes-Benz C-Class Coupé is shown from a low-angle, rear-quarter perspective, driving on a runway. The car is in motion, with a blurred background of yellow lights and a clear blue sky. The runway has a yellow center line and a row of yellow lights on the right side. In the distance, there are white buildings and a clear blue sky with some light clouds.

Short journeys are a must. At least when it comes to shift travel

As memorable as a drive in the new C-Class Coupé is, the only inkling you get of gear changes is in the pulling power. Even the 4-cylinder models now come with the option of the 7G-TRONIC PLUS automatic transmission to do practically all of this for you. The only one in the car that needs to do any work is your rev counter. → Page 34

Two doors, no compromises.
As coupé as it gets!

The low silhouette with a long, arrow-shaped bonnet. The upright, louvred radiator grille with a central star, the strong shoulders, short overhangs and a powerfully thrusting rear end. Every inch underlines the character of this Coupé: built for people who don't like to stand still.





Brief care instructions:
needs tarmac beneath its tyres every day







Don't think too much about the environment.
We've already done that for you

Intelligent drive systems are a sign of the times. That's why the new C-Class Coupé features optimised engine technology – with a choice of three efficient petrol variants and two diesel variants. Additional fuel-saving potential comes courtesy of the standard-fit ECO start/stop function and the optionally available 7G-TRONIC PLUS automatic transmission. Good news for CO₂ emissions. → Page 30–34



Welcome to the coupé lounge







Just what you need: a seventh sense

The new C-Class Coupé is always a little bit further ahead than you think. Thanks to numerous safety systems which take account of practically every eventuality and thus help to prevent hazardous situations. A perfect case in point is the ADAPTIVE BRAKE braking control system, which has the ability to apply the brakes in anticipation of danger. So, if the worst comes to the worst, the car can be brought to a stop even more quickly. It's reassuring for all concerned, not just your heart rate.





Maybe your first Mercedes.
Almost certainly not your last







Standing ovation





How do you make something unique even more unique? The list of equipment is a good place to start. The Style package, for example, emphasises the car's expressive character with a contrasting interior colour scheme, a piano lacquer-style trim and a leather look. The only things more individual than the interior are the places to which this Coupé can take you. → Page 44, 61

How do you design exhilaration?





Aerobats perform their daredevil manoeuvres as if in a frenzy, mastering figures at breathtaking speed. Suddenly, as if time were standing still, they appear to hang in the air for a moment. The spectators hold their breath in total silence. Then the plane plummets towards the ground, seemingly out of control. Yet at no point does the pilot lose control of his machine. With his hands firmly on the joystick, he halts the plane's fall and starts to spiral upwards. The flown figure is an expression of agility. And the thoughts and ideas behind it apply as much to a car's interior as they do to a plane's cockpit. Because both the silhouette and the character of every car start to take shape on the drawing board. But how do you design enjoyment? How can you make people see and, above all, experience it?

It's like the figures flown in aerobatics: it looks like a game – yet it's a matter of the utmost accuracy and precision. Because driving pleasure means perfect mastery of the machine. It is created on the fine line between optimum driver assistance provided by control and safety systems on the one hand and maximum performance on the other. By way of example, numerous assistance systems need to provide support but not be perceived as restrictive. Armed with this knowledge, the designers succeed in achieving the ultimate aim: creating a car with agility and dynamism to lend wings to its driver's imagination.

. Light. Multimedia systems. kW at rpm. In the event of danger. Assistance systems.
e driving. Upholstery. Trim. g/km. Wheels. Services. Nm at rpm. Trim. Dimensions. S
Chassis & suspension. Fuel. Exterior. Chassis & suspension. Technical data. Rated ou
ment. Trim. Sustainability. Fuel consumption. Acceleration. Exterior. Diesel engines.
stems. kW at rpm. In the event of danger. Assistance systems. Seats. Climate control.
m. g/km. Wheels. Services. Nm at rpm. Trim. Dimensions. After an accident. Paintwo
technical data. CO₂. Rated output. In an accident. Emissions standard. Top speed. Fue
Exterior. Upholstery. Trim. g/km. Wheels. Services. Nm at rpm. Total displacement. I
. Standard equipment. Fuel. Acceleration. Exterior. Diesel engines. Transmissions. C
rpm. In the event of danger. Assistance systems. Seats. Safe driving. Upholstery. Trim
. Acceleration. **The facts.** Total displacement. Interior. After an accident. Light. Multi
. Equipment packages. Petrol engines. Optional extras. Safe driving. Trim. g/km. Wh

28 **BlueEFFICIENCY**29 **C-Class Coupé BlueEFFICIENCY**

30 **Diesel engines**
4-cylinder

32 **Petrol engines**
4-cylinder
6-cylinder

34 **Transmissions**
6-speed manual transmission
7G-TRONIC PLUS

35 **Chassis & suspension**
AGILITY CONTROL suspension
Dynamic Handling package
with sports driving mode

36 **Safe driving**
Driving Assistance package Plus
Intelligent Light System
LED tail lights and adaptive
brake lights
ATTENTION ASSIST

38 **In the event of danger and in
an accident**
PRE-SAFE®
NECK-PRO head restraints
Airbags
Active bonnet

40 **Multimedia systems**
COMAND Online
Harman Kardon® Logic 7®
surround sound system
Audio 20
Becker® MAP PILOT

42 **Assistance systems**
Speed Limit Assist
Reversing camera
PARKTRONIC incl. Parking Guidance
Lane Tracking package

44 **Seats**
Coupé seats
Luxury individual rear seats
Memory package

46 **C 63 AMG exterior**48 **C 63 AMG interior**

50 **C 63 AMG technology**
AMG 6.3-litre V8 engine
AMG sports suspension
AMG SPEEDSHIFT MCT 7-speed
sports transmission

52 **AMG Performance Studio**

The C-Class Coupé in detail

54 Standard equipment**55 Optional extras****56 Equipment packages**

AMG Sports package

designo

Style package

62 Upholstery and trim**68 Wheels**

Standard wheels

Optional wheels

AMG wheels

70 Genuine accessories**72 Services**

Mercedes-Benz Museum

MercedesCard

Mercedes-Benz Financial Services

Mercedes-Benz mobility

Service packages

Test drive

Interactive Owner's Manual

Mobile internet

74 Dimensions**74|77 Paintwork****75 Technical data**

BlueEFFICIENCY – fast forward to tomorrow



Mercedes-Benz is quicker at getting future technologies to where it matters most: on the road. By the end of 2011, we will be able to offer you 128 Mercedes-Benz models with BlueEFFICIENCY technologies, all of which help you reduce your impact on the environment. Our BlueEFFICIENCY concept comprises innovations for efficient mobility as well as optimised processes all the way along the value chain.

The BlueEFFICIENCY measures – the Mercedes-Benz efficiency package. This package consists of comprehensive vehicle optimisations which ease the burden on the environment. Each model combines the most efficient engine with intelligent, latest-generation aerodynamic and energy-management measures. Such measures include the ECO start/stop function, which is being made available for an increasing number of models. The new BlueDIRECT V6 and V8 petrol engines, which feature in several model series, deliver a much higher power output while reducing fuel consumption by up to 24%.

BlueTEC – the clean diesel. A modular emission-control system makes BlueTEC an exceptionally clean diesel technology. As well as removing 95% of the particulate, it also reduces nitrogen oxides by up to 90%. What remains is mainly water and nitrogen.

HYBRID – the intelligent combination of petrol and electric drive. Here the electric motor can be used both for accelerating and for recuperating braking energy, which is stored in the battery. What's more, the ECU shuts off the petrol engine when the speed is below 15 km/h. In this way, a HYBRID can reduce fuel consumption by up to 20%.

BlueTEC HYBRID – clean diesel combined with electric drive. It marries the benefits of the HYBRID with those of BlueTEC: during braking, the kinetic energy is converted into electrical energy, which can be re-used when required. At the same time, the BlueTEC technology cleans the exhaust gases and removes

many of the pollutants. All of which makes the economical diesel powerplant even more efficient and clean.

Innovative drive systems that break new ground: E-CELL and F-CELL. We have developed two locally emission-free drive systems which have been produced on a small scale since 2010. The B-Class F-CELL uses hydrogen to produce power for the electric motor, while the A-Class E-CELL draws its energy directly from two lithium-ion batteries.

But that is not all: under the banner "Design for Environment", we also look at a vehicle's entire lifecycle and work hard to preserve the environment from the planning stage right through to recycling. In addition, we are involved in the development of alternative fuels and carry out research in the field of bionics. Further information about our comprehensive measures can be found at www.mercedes-benz.com/blueefficiency

C-Class Coupé BlueEFFICIENCY

At Mercedes-Benz, BlueEFFICIENCY stands for trend-setting efficiency technologies and innovative measures. The new C-Class Coupé models work with BlueEFFICIENCY technologies.



Thanks to BlueEFFICIENCY, the new C-Class Coupé requires very little fuel. That's because the engine is stopped automatically – largely unnoticed by the driver – when the car is at or coming to a standstill. Intelligent energy management reduces the energy consumption of ancillary components. Tyres with optimised rolling resistance and the car's optimised aerodynamics further lower the amount of energy consumed.

- 1 Radiator shutter
- 2 Improved aerodynamics
- 3 Weight optimisation
- 4 Engine optimisation
- 5 Intelligent energy management
- 6 ECO start/stop function
- 7 Driver information for energy-saving driving
- 8 Tyres with optimised rolling resistance
- 9 Energy-saving control of ancillary components
(power steering pump, fuel pump in the case of diesel engines)
- 10 Refrigerant compressor only activated when actually needed

Diesel engines

The diesel engines for the new C-Class Coupé make for efficient, refined and powerful progress. They have higher outputs yet can consume far less fuel than their conventional counterparts.

4-cylinder engines. The diesel powerplants incorporate a wealth of technical innovations. As a result, their output is up to 20% higher than that of comparable

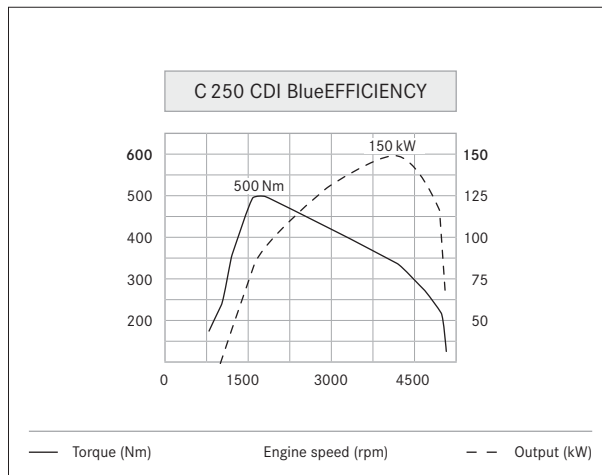

Impressive torque, even at low revs: ideal for spontaneous bursts of speed

older engines: the C 220 CDI BlueEFFICIENCY delivers 125 kW, the C 250 CDI BlueEFFICIENCY 150 kW. At the same time, the torque of both engines has been increased by up to 25%, while fuel consumption and CO₂ emissions are up to 23% lower. Both models also feature the ECO start/stop function and meet the requirements of the Euro 5 emissions standard.

One of the reasons behind the impressive performance of the diesel engines is the maximum injection pressure of 2000 bar. What's more, the required fuel quantity is metered extremely precisely – a sound basis for efficient and on-demand use of energy.

The diesel engines' astonishing consumption/output ratio is also down to their optimised combustion chamber design, which offers ideal conditions for maximising both clean combustion and energy efficiency. At the same time, the optimised alternator management helps take

the strain off the engine by seeing to it that the alternator is only activated when it is actually needed. A further technology which promotes responsible-minded driving pleasure is the efficiency-enhancing turbocharger. Plus there are two balancer shafts to ensure even smoother running.



The 4-cylinder diesel engine is available with a choice of two outputs (C 220 CDI BlueEFFICIENCY shown here)



The 6-cylinder engine for the C 350 BlueEFFICIENCY combines agility with responsible-minded energy consumption

Petrol engines

Agility and efficiency go hand in hand, as demonstrated by the petrol engines. Both the 4-cylinder models and the V6 powerplant combine a high level of refinement with low fuel consumption.

4-cylinder engines. One key aim of the latest-generation 4-cylinder petrol engines is to ensure higher output and better acceleration but lower fuel consumption. This aim

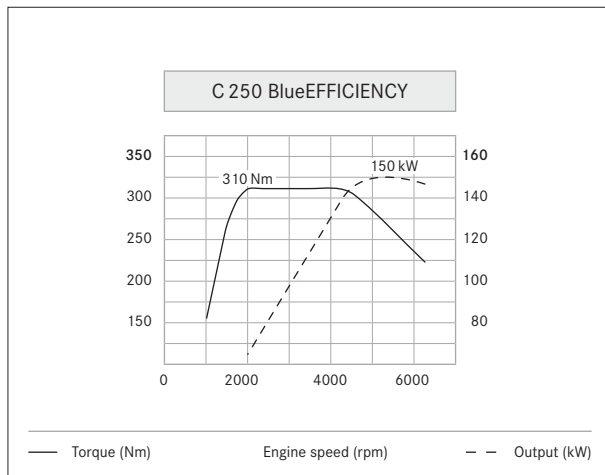

Not just remarkable in terms of performance data. The fuel-consumption figures set new standards, too

is achieved with ease thanks to the BlueEFFICIENCY technologies – including the ECO start/stop function – and other optimisation measures. Meaning that the engines consume less fuel than comparable models.

Performance potential: the C 180 BlueEFFICIENCY with 7G-TRONIC PLUS accelerates from 0 to 100 km/h in just 8.9 seconds and goes on to reach a maximum speed of 223 km/h. The C 250 BlueEFFICIENCY has a top speed of 240 km/h and completes the sprint from 0 to 100 km/h in 7.2 seconds.

6-cylinder engine. Economical, clean and high-torque: the new C 350 BlueEFFICIENCY heralds the arrival of a new generation of technology – drive concepts that are sparing in their use of resources. With combined fuel consumption of 6.8–7.0 l/100 km, the engine has a peak output of 225 kW and can accelerate the new C-Class Coupé from 0 to 100 km/h in a mere 6.0 seconds.

The maximum torque of 370 Nm is on tap across a particularly wide engine speed range, so impressive power reserves are available for practically any driving situation.

This astonishing performance is the result of many features, including continuously variable camshaft adjustment, which allows precise, on-demand use of fuel. Latest-generation direct petrol injection, spray-guided combustion and piezo injectors combine to minimise fuel consumption.

Transmissions

The two transmissions available for the new C-Class Coupé deliver optimum pulling power across all engine speed ranges and in every driving situation.

6-speed manual transmission. The 6-speed manual transmission combines sporty and economical driving. The ratio optimised in line with the engine output and the extremely precise, short shift travel make for exceptionally smooth gear changes. What's more, the integrated gearshift-recommendation function, ECO start/stop function and current consumption indicator can help to optimise fuel consumption and reduce emissions. For instance, the ECO start/stop function stops the engine when the car is at or coming to a standstill – at traffic lights, for example – before restarting it when the clutch or accelerator pedal is pressed.

7G-TRONIC PLUS. The new efficiency-optimised 7G-TRONIC PLUS automatic transmission is one of the major factors behind the exceptionally high level of driving enjoyment. The seven forward gears allow a constantly optimised rpm level, meaning that fuel consumption can be reduced. But the transmission technology also comes into play when the driver wants to accelerate powerfully or experience the full range of the new C-Class Coupé's agility. By way of example, individual gears can be skipped when overtaking or in situations requiring spontaneous acceleration. Furthermore, the transmission modes "C" (Comfort) and "S" (Sport) can be selected at the touch of a button. The optional AMG Sports package and the optional Dynamic Handling package with sports driving mode also come with an additional "M" driving mode for

manual shifts using the steering-wheel shift paddles. The new 7G-TRONIC PLUS transmission is available as standard for the C 250 BlueEFFICIENCY and C 350 BlueEFFICIENCY models or as an optional extra for all other models.

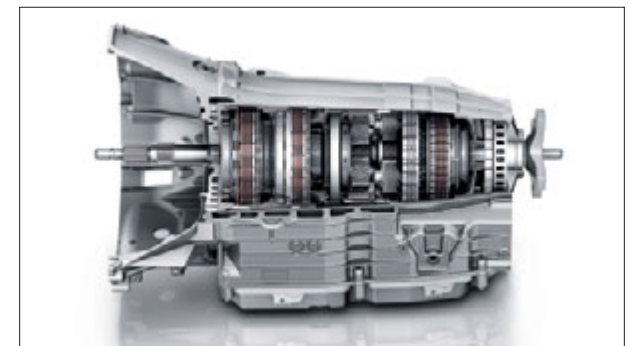

7G-TRONIC PLUS: one of over 18 million automatic transmissions produced in a period spanning more than 50 years

Chassis & suspension

The chassis technology for the new C-Class Coupé allows comfort-oriented or sporty driving with supreme agility in almost any situation on the road.

AGILITY CONTROL suspension (standard). The suspension with selective damping system can adjust automatically to the current road conditions and driving style. To do this, a valve automatically reduces the damping force at each wheel when the shocks caused by the road are weaker, thus lowering road roar and tyre vibration. If these shocks are stronger, the system's damping effect is enhanced and can improve the car's driving stability.

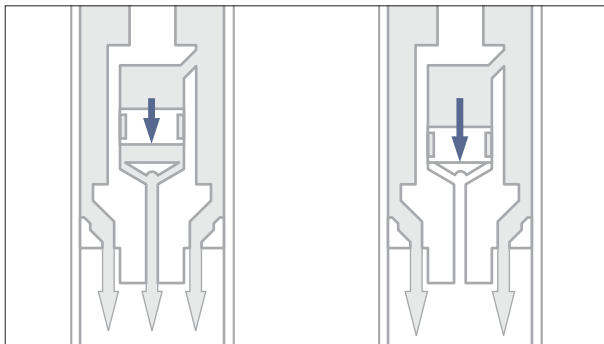

Outstanding agility and a high level of comfort: the AGILITY CONTROL suspension can adapt to any driving style

Dynamic Handling package with sports driving mode (optional). The optionally available Dynamic Handling package with sports driving mode lends the new C-Class Coupé even more dynamism and enhances the driving pleasure on every journey: in sports mode, the system not only adjusts the firmness of the damping, it also sharpens the accelerator response. Whatever the selected mode, the electronically controlled damping system constantly adjusts in line with the driving

situation and the state of the road. Driving pleasure is further enhanced by the 3-spoke multifunction steering wheel in nappa leather with shift paddles (in conjunction with automatic transmission). What's more, the speed-sensitive sports steering has a modified steering response map and a direct ratio for an exceptionally sporty feel. Finally, the lower-slung chassis delivers extra dynamism when cornering at high speed.



The Dynamic Handling package works together with a suspension system lowered by 15 millimetres, for example

Safe driving

The new C-Class Coupé features safety equipment which helps to make everyday driving more relaxing and ensure better control in critical driving situations.

Driving Assistance package Plus (optional). At the touch of a button, the DISTRONIC PLUS adaptive cruise control can help the driver to maintain the desired distance behind a vehicle in front at speeds between 0 and 200 km/h and, if the need is detected, initiate braking. In this case, the radar-based system can brake the car to a standstill. It anticipates situations and builds up the necessary brake pressure. If the driver fails to press the brake pedal hard enough during emer-

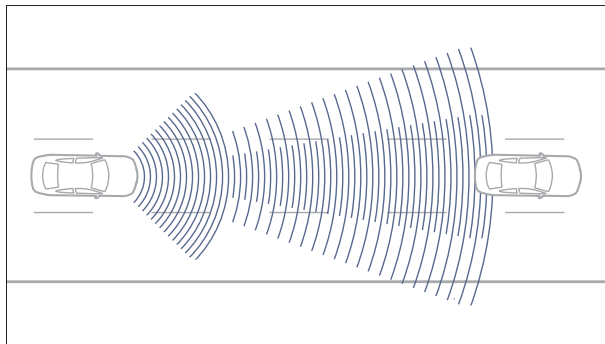

The DISTRONIC PLUS adaptive cruise control can brake the car to a standstill, for example when driving in a queue of traffic

gency braking, for example, the integrated BAS PLUS function boosts the braking power. Thanks to the PRE-SAFE® Brake, the system can initiate emergency braking around 0.6 seconds before a possible collision to reduce the severity of the accident. Active Blind Spot Assist helps the driver when turning or changing lanes. A warning triangle lights up in the exterior mirror on the side of the car concerned if a vehicle is detected in the blind spot. If the driver fails to respond to the

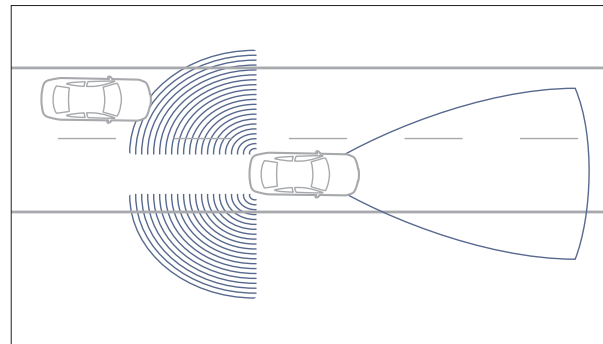

Active Blind Spot Assist warns the driver if it detects a vehicle in the blind spot

warning, the system can prevent a possible accident by automatically braking individual wheels. If the vehicle unintentionally crosses the detected lane markings and risks leaving its lane, Active Lane Keeping Assist warns the driver by making the steering wheel vibrate gently. If the driver fails to respond, individual wheels can be braked precisely to guide the vehicle back into its lane. Active Lane Keeping Assist recognises contrasts on the road ahead of the vehicle and is therefore able to “read” lane markings. It also observes the driving style and the line taken by the car, analysing these data for movements typical of a vehicle leaving its lane unintentionally. In this way, the system is able to reliably distinguish between intentional and unintentional lane departures.

Intelligent Light System with Adaptive Highbeam Assist and LED daytime driving lights (optional). The headlamp system with LED daytime driving lights optimises visibility. It distinguishes between country mode and motorway mode – for optimum illumination of the road ahead. The active light function ensures the headlamps follow the steering angle, while Adaptive High-Beam Assist dims the headlamps automatically when another vehicle with its lights on is detected.

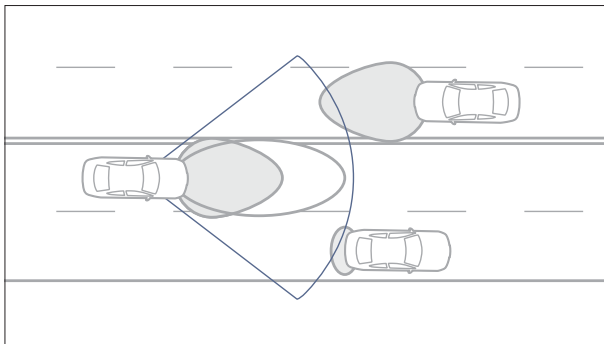

The Intelligent Light System adapts the car's lights to the current driving situation automatically

LED tail lights and adaptive brake lights (standard). During emergency braking, the adaptive brake lights flash 5.5 times per second to warn the traffic behind you. If the car is braked to a complete stop from a speed in excess of 70 km/h, the hazard warning lamps are also switched on.



The LED tail lights and the adaptive brake lights enhance perceptual safety

ATTENTION ASSIST (included with the optional 3-spoke multifunction steering wheel with 12 buttons). The system can warn the driver and recommend taking a break as soon as it detects signs of driver drowsiness. To do this, it monitors the driver's behaviour and, if this deviates from a previously determined profile, visual and audible warnings are emitted.



If Attention Assist detects signs of drowsiness, the system recommends taking a break

In the event of danger and in an accident

Mercedes-Benz represents the pinnacle of automotive safety. Even in critical driving situations or in an accident, the new C-Class Coupé can protect its occupants thanks to its modern technology and innovative systems.

PRE-SAFE® (optional). The occupant protection system can detect critical driving situations and, if necessary and as a precaution, activate safety systems which help to reduce the risk of injury to the vehicle occupants. It is therefore possible to activate the electronic belt tensioners, move the electrically adjustable seat into a more ideal position from an accident standpoint and close the windows automatically within a fraction of a second.

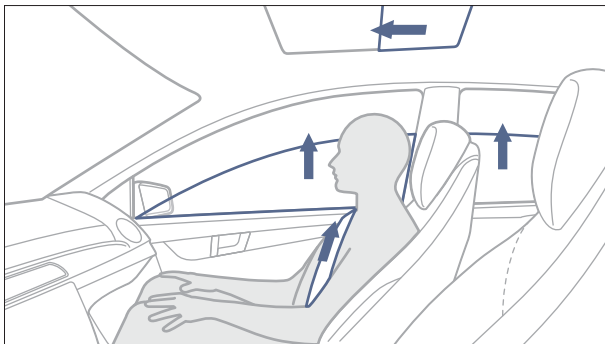

PRE-SAFE® can use the valuable seconds before a potential accident to prepare the occupants as well as possible for an impact

NECK-PRO head restraints (standard). In the event of a rear impact, the sensor-controlled NECK-PRO head restraints for the front passengers can be pushed forward and upward within a matter of milliseconds. They can thus reduce the gap between the head and the head restraint, thereby reducing the risk of injury.

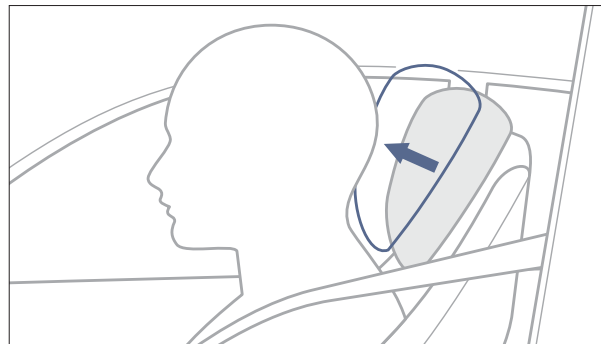

The NECK-PRO head restraints can help to reduce the risk of whiplash in an accident

Airbags (standard). The new C-Class Coupé is equipped with numerous airbags which can help to reduce the risk of injury to passengers considerably in an accident. Driver and front-passenger airbags, sidebags and pelvisbags at the front, a kneebag for the driver, and windowbags are fitted as standard, while rear sidebags are optionally available.

Active bonnet (standard). The active bonnet can reduce the risk of injury to pedestrians and cyclists. In the event of an impact, its rear section is raised around five centimetres by means of spring force, thus creating additional deformation space to soften the blow for a pedestrian or cyclist.

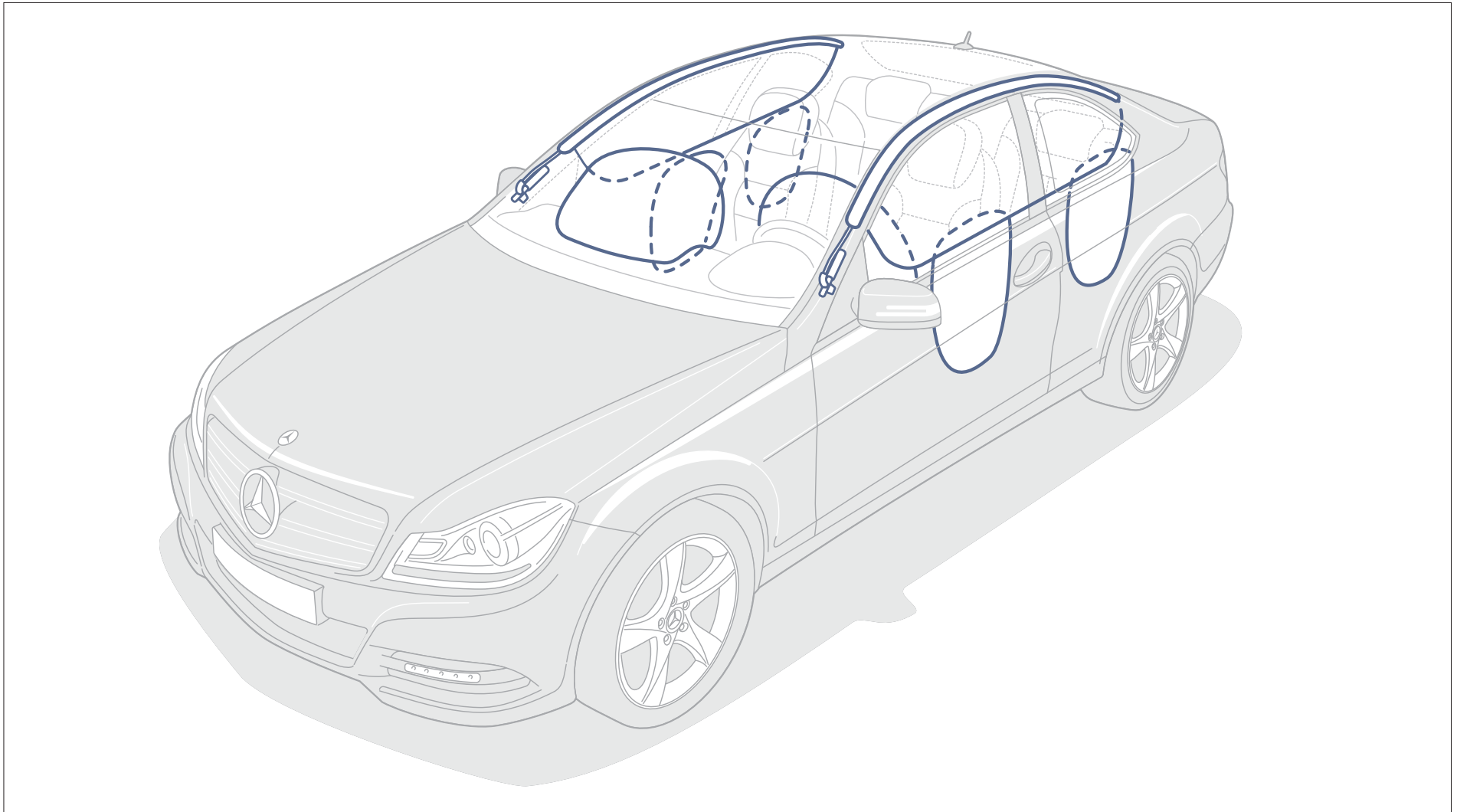

The robust passenger cell with defined crumple zones and the extensive safety equipment, including restraint systems, make for exemplary occupant protection

Multimedia systems

To drive in style, you also need quality entertainment and helpful navigation. Cue our outstanding entertainment electronics and excellent navigation systems.



As well as displaying navigation data in high resolution, the large TFT display also optimises the display of web and multimedia content

COMAND Online (optional). The multimedia system boasts a high-resolution 17.8 cm colour display. The system's functions include a radio, speed-sensitive volume control, the MUSIC REGISTER with a 10 GB hard disc and hard-disc navigation. What's more, it also includes free European map data updates for three years following initial registration. The best in entertainment is provided courtesy of the DVD player, which can play CDs and MP3 files as well as video and audio DVDs. The online function facilitates access to the internet and various Mercedes-Benz mobile services via an internet-capable mobile phone. A USB connection, an Aux-in socket, a slot for SD memory cards and a Bluetooth® interface allow connection to external data storage media and a mobile phone. The system is operated using the central Controller and the buttons on the 3-spoke multi-function steering wheel. The LINGUATRONIC system allows you to control COMAND Online using voice commands.

Harman Kardon® Logic 7® surround sound system (optional). The surround sound system with 450 watts is sure to make every one of your journeys an acoustic experience to savour. Twelve high-performance speakers and the Logic 7® multi-channel surround sound technology provide a three-dimensional sound impression. The automatic volume control adapts the sound in line with the car's current speed.



All you need for pure musical enjoyment: the Harman Kardon® Logic 7® surround sound system

Audio 20 with Bluetooth® interface, USB connection and Aux-in socket (standard). Includes a radio function as well as a CD player with MP3 capability. The system is controlled via the multifunction steering wheel and the TFT display with a screen diagonal of 14.7 cm. A mobile phone can be linked via Bluetooth® for hands-free operation. There are also numerous interfaces available.



Audio 20 with eight precisely tuned speakers for delivering outstanding sound

Becker® MAP PILOT (optional). The new Becker® MAP PILOT reliably gets you to your destination and has everything you look for in a sophisticated navigation system. It is installed in the glove compartment and can be simply controlled via the central Controller and the Audio 20 CD system's display. What's more, it can be further personalised by downloading updated map data and additional functions.

Assistance systems

The new C-Class Coupé is designed to help you relax on the way to your destination. That's why it offers systems that can assist you and make your life easier in a wide range of traffic situations, for example when parking, when driving from city to city on roads with variable speed limits or when facing challenging road conditions.



Speed Limit Assist shows the driver the current speed limit

Speed Limit Assist (part of the optional COMAND Online system). Most of the world's serious road accidents occur as a result of drivers failing to adapt their speed. This assistance system enhances safety and ride comfort as well as making the driver's job easier by indicating detected current speed limits on the central display in the cockpit. The risk of not seeing a speed-limit sign is therefore reduced, especially on routes with variable speed limits or road works. The indication remains on the display until the speed limit is lifted or a new speed limit comes into force.

Reversing camera (optional). The optional reversing camera offers better visibility when parking and reversing. The area around the rear of the vehicle is shown on the COMAND display. The reversing camera is only available in conjunction with the optional COMAND Online multimedia system.



The reversing camera makes it easier to perform many manoeuvres when space is at a premium

PARKTRONIC including Parking Guidance (optional). This electronic system helps the driver to look for and park in parking spaces. It emits audible and visual warnings as soon as it detects that the car is approaching an obstacle during a manoeuvre. It can also locate suitable parking spaces and provide the driver with precise instructions regarding the correct steering angle as well as the turn-in and turn-back points.



Parking Guidance automatically calculates the length of parking spaces at speeds up to 36 km/h

Lane Tracking package (optional). Lane Keeping Assist can detect a traffic lane based on the white road markings and, if the car is about to leave its lane unintentionally, warn the driver by making the steering wheel vibrate gently. Blind Spot Assist, meanwhile, uses two radar sensors in the rear bumper to monitor the blind spot at speeds above 30 km/h and can warn the driver against dangerous lane changes.



Blind Spot Assist is available as part of the optional Lane Tracking package

Seats

The new C-Class Coupé is fitted with specially designed coupé seats including integrated head restraints and luxury individual rear seats. As well as being style-defining, the seat design offers extremely effective support, even during sporty driving, and perfect ergonomics.



The standard-fit coupé seats are ergonomically designed. You can tell that they are made for a highly agile car: the new C-Class Coupé

Coupé seats. Ergonomic coupé seats upholstered in a combination of ARTICO man-made leather and fabric await the driver and front passenger; ARTICO man-made leather or genuine leather upholstery is optionally available. Both the seat cushion height and the backrest inclination are electrically adjustable at the push of a button. Heated or climatized seats are available as optional extras.

Luxury individual rear seats with integrated head restraints. The lounge-like character of the interior is also reflected in the luxury individual rear seats with integrated head restraints. An asymmetrically split and folding rear seat backrest is included as standard (except in the C 180 BlueEFFICIENCY). Convenience is further enhanced by the manually operated EASY-ENTRY system, which makes it easier to get into and out of the car.



Sheer comfort: it's easy for rear passengers to get into the car thanks to the EASY-ENTRY system, which moves the front seats fully forwards in one simple move

Memory package (optional). This package extends the range of seat settings and, if several people drive the car, ensures that each driver can adopt their preferred sitting position quickly by calling up their own pre-programmed settings - for the driver's seat, steering column and exterior mirrors - at the touch of a button. In addition to this, the Memory package includes 4-way lumbar support for both the front seats.



The ergonomic driver's seat moves into the pre-programmed desired position at the touch of a button



C 63 AMG exterior

The new C 63 AMG is the epitome of an expressive coupé. The AMG front apron, the AMG radiator grille with one chrome louvre, the unique AMG bonnet with powerdomes, the unique AMG daytime driving lights, the side sill panels and the rear apron with inset diffuser are just some of the features that demonstrate its commitment to performance. The AMG sports exhaust with two chromed twin tailpipes likewise emphasises the high-performance credentials of the new Coupé and shows unequivocally that this particular Mercedes-Benz is powered by an AMG drive system. The exterior is finished off perfectly by AMG light-alloy wheels, further underlining the fact that this is a highly responsive car built for motoring enjoyment. Further exterior features are listed below.



EXTERIOR

AMG 5-twin-spoke light-alloy wheels, painted titanium grey with a high-sheen finish, with 235/40 R 18 front tyres and 255/35 R 18 rear tyres

AMG bodystyling, comprising front apron with side air outlets and cross strut in high-gloss black, side sill panels and diffuser-look rear apron

AMG high-performance braking system with 360 x 36 mm front discs and 330 x 26 mm rear discs

AMG spoiler lip on the boot lid

Distinctive, flared front wings with "6.3 AMG" lettering

LED tail lights







C 63 AMG interior

Powerful on the outside, stylish on the inside. The interior of the new C 63 AMG Coupé is based on a concept that has been well thought-out right down to the last detail. As soon as you open the doors, the AMG door sill panels tell you that this car is something truly special. Passengers are then welcomed by AMG sports seats upholstered in a combination of ARTICO man-made leather and DINAMICA in black or, as an option, designo leather (single-tone or two-tone). The AMG performance steering wheel, featuring flattened top and bottom sections, is equipped with aluminium shift paddles, while the AMG instrument cluster with colour display and AMG Start-up indicator is in an ergonomically ideal position. The black roof lining and the AMG sports pedals complete the sporty ambience.

INTERIOR

AMG door sill panels in brushed stainless steel

AMG instrument cluster, incl. RACETIMER and AMG Start-up indicator

AMG performance steering wheel in nappa leather, with flattened top and bottom sections and silver-coloured aluminium shift paddles, incl. ATTENTION ASSIST

ATTENTION ASSIST

AMG speed-sensitive sports steering

AMG sports seats in ARTICO man-made leather/DINAMICA, black

Brushed stainless-steel sports pedals with rubber studs

High-gloss black piano lacquer-style trim

Rotary switch for selecting the four transmission modes and Race Start function

C 63 AMG technology

The AMG 6.3-litre V8 naturally aspirated engine and the AMG SPEEDSHIFT MCT 7-speed sports transmission offer an emotional driving feel and driving dynamics at the highest level. Yet when it comes to choosing a sporty or comfort-oriented driving style, the driver always has the final say in the new C-Class Coupé.

AMG 6.3-litre V8 engine. A high-revving naturally aspirated engine with thoroughbred motor-racing technology: the vertical arrangement of the intake and exhaust ducts as well as the magnesium variable-intake manifold with two integrated throttle valves ensure optimum charging of the eight cylinders. Further high-tech features include the variable camshaft adjustment, four valves per cylinder, the stiff aluminium crankcase and the low-friction TWAS (twin-wire-arc-spraying) coating used for the cylinder walls. The V8 powerplant develops 336 kW at 6800 rpm, delivering impressive pulling power and a torque of 600 Nm at 5000 rpm. Ideal ingredients for powerful acceleration in every engine speed range, as the driver always has over 500 Nm on tap between 2000 and 6250 rpm. Adding the AMG Performance package boosts the output by 22 kW to 358 kW, enabling the car to accelerate from 0 to 100 km/h in a highly impressive 4.4 seconds.

AMG sports suspension. Superlative driving dynamics and thrilling driving enjoyment come courtesy of the AMG sports suspension with AMG 5-twin-spoke light-alloy wheels with 235/40 R 18 front tyres and 255/35 R 18 rear tyres in combination with the specially designed three-link front suspension with a wider track, the AMG speed-sensitive sports steering and the three-stage ESP®. The AMG speed-sensitive sports steering has an even more direct ratio and, therefore, offers greater steering precision at high cornering speeds. The AMG sports suspension's stiff springs, gas-pressure shock absorbers and unique axle kinematics provide optimum agility at the driving limits as well as outstanding lateral dynamics. The AMG sports suspension therefore combines driving dynamics at the highest level with hallmark Mercedes long-distance comfort – and thus displays the characteristic attributes of a true AMG. The Electronic Stability Program ESP® has been specially adapted in

line with the high level of driving dynamics, as it allows the driver to select the level of assistance provided by the dynamic handling control system by choosing one of three different control settings: ON, SPORT or OFF. The activated setting is shown on the AMG instrument cluster's central display. The AMG high-performance braking system featuring large, internally ventilated and perforated brake discs ensures outstanding levels of deceleration and fade resistance. Not to mention perfect brake control and extremely short stopping distances.

AMG SPEEDSHIFT MCT 7-speed sports transmission.

Equipped with AMG aluminium steering-wheel shift paddles, four modes and a Race Start function, the 7-speed automatic transmission delivers enhanced driving dynamics and is highly efficient. The “S” (Sport), “S+” (Sport Plus), “C” (Comfort) and “M” (Manual) modes each have different gear-change characteristics and speeds: gear changes in “S” and “S+” modes are around 20 or 40 percent quicker than in “C” mode respectively - while in “M” mode gear changes take just 100 milliseconds, making them some 50 percent faster. A push of a button activates the desired driving mode: distinctly sporty or more comfort-oriented. There is also an automatic double-declutching function when downshifting, which provides an emotional sound experience as well as reducing power-off effects. This function has a positive effect when braking on the approach to bends in particular.

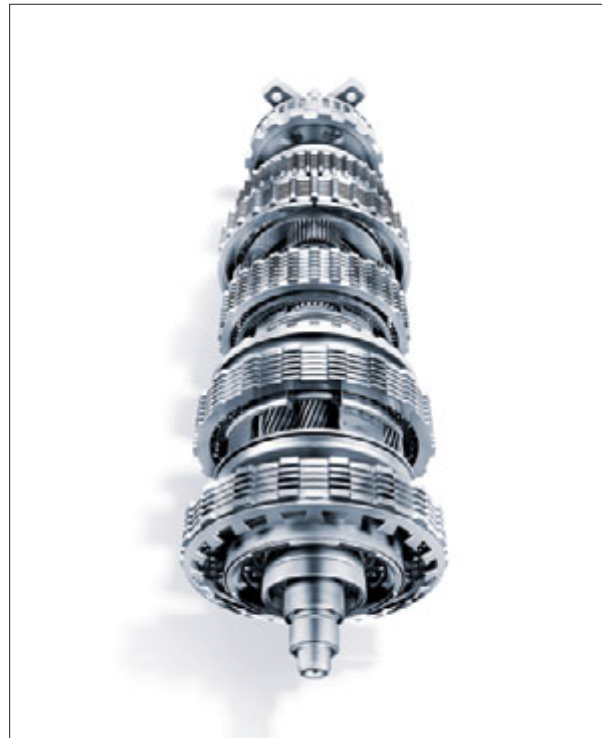

The AMG SPEEDSHIFT MCT 7-speed sports transmission offers customised modes for maximum driving pleasure



Motor-racing technology gives the AMG 6.3-litre V8 engine maximum agility





AMG Performance Studio

The C 63 AMG can be made even more sporty by the many exclusive features on offer from the AMG Performance Studio, such as the AMG Performance package, which includes a 22 kW boost in output, an AMG performance steering wheel in nappa leather/Alcantara®, AMG high-performance compound brakes on the front axle, an AMG carbon-fibre spoiler lip, red painted brake callipers at the front and rear, and a variable intake manifold painted in titanium grey. Over and above this, the AMG Driver's package provides a top speed of 280 km/h and includes participation in driving training at the AMG Driving Academy. The AMG Performance Studio in Affalterbach can meet customer requests for personalised vehicles, special optional extras and even one-off models.

AMG PERFORMANCE STUDIO

AMG 45.7 cm (18-inch) 5-spoke light-alloy wheels in titanium grey and 48.3 cm (19-inch) multi-spoke light-alloy wheels in titanium grey or matt black

AMG carbon-fibre trim

AMG door sill panels, illuminated with white LEDs at the front

AMG Driver's package

AMG Exterior Carbon-Fibre package (carbon-fibre spoiler lip and exterior mirror housings)

AMG floor mats

AMG rear-axle differential lock

Standard equipment | Selection



Daytime driving lights and front fog lamps



3-spoke multifunction steering wheel with 4 buttons in nappa leather, perforated in the grip area



THERMATIC automatic climate control



Coupé seats



LED tail lights



Audio 20 CD



ECO start/stop function



USB connection and Aux-in socket

Optional extras | Selection



Heat-insulating tinted rear window and rear side windows



Exterior Chrome package



3-spoke multifunction steering wheel with 12 buttons in nappa leather, perforated in the grip area



KEYLESS-GO drive authorisation system



Panoramic sliding sunroof



Mirror package



COMAND Online multimedia system with LINGUATRONIC



Media Interface



AMG Sports package

The optionally available AMG Sports package lends the new C-Class Coupé an even more dynamic and athletic appearance as well as enhancing its sporty agility. On the outside, it emphasises the Coupé's visible forwards thrust with AMG 7-spoke light-alloy wheels and AMG bodystyling, including front and rear aprons as well as side sill panels. The AMG Sports package also includes sports suspension and speed-sensitive sports steering to emphasise the car's effortlessly superior agility.



EXTERIOR

AMG 7-spoke light-alloy wheels with mixed-size tyres: 225/40 R 18 at the front and 255/35 R 18 at the rear

AMG bodystyling comprising front apron, side sill panels and rear apron

Brake callipers with Mercedes-Benz lettering, perforated front brake discs

Lowered sports suspension

Speed-sensitive sports steering

Tailpipe trim in polished stainless steel







AMG Sports package

The unique features of the optionally available AMG Sports package lend the interior of the new C-Class Coupé extra dynamic touches: the 3-spoke multi-function sports steering wheel with a flattened bottom section allows the driver to change gear using steering-wheel shift paddles (only in conjunction with automatic transmission), while the speed-sensitive sports steering enhances the car's sporty handling. The roof lining is finished in black fabric. A generously sized instrument cluster with an 11.4 cm colour display and ATTENTION ASSIST catches the eye without distracting the driver's attention from the road. The sporty interior is rounded off perfectly by an aluminium trim, brushed stainless-steel sports pedals and AMG floor mats.

INTERIOR

3-spoke multifunction sports steering wheel with flattened bottom section and 12 buttons in nappa leather, perforated in the grip area, incl. ATTENTION ASSIST

Black floor mats with AMG lettering

Brushed stainless-steel sports pedals with rubber studs

Dark brushed aluminium trim

Roof lining in black

Steering-wheel shift paddles (only in conjunction with automatic transmission)

designo

The designo range allows you to design the new C-Class Coupé to an even higher standard and to your own taste.

The wide range of exclusive designo appointments available as optional extras allows you to personalise an already exceptional vehicle. The single-tone appointments including seats and armrests in designo leather and leather-trimmed door centre panels featuring a hallmark designo look create a high-quality, exclusive atmosphere. Regardless of whether you choose the designo leather in sand, black, porcelain or classic red. And should you wish to further emphasise your Coupé's individuality, designo offers a vast range of additional options.



The two-tone appointments in designo leather highlight the Coupé's sporty, dynamic side. There is a choice of combinations available for the designo leather: sand/black, porcelain/black or classic red/black. As in all Mercedes-Benz models, the metal badge in the backrest is proof of meticulous material selection, exceptional quality, careful craftsmanship and individuality at the highest level. The interior is completed by the extended appointments in designo black leather comprising a leather finish for the upper section of the dashboard.



Style package

The Style package further emphasises the sporty and individual interior style of the new C-Class Coupé.

The Style package comprises a number of high-quality, harmoniously combined details. The upholstery in black ARTICO man-made leather with contrasting porcelain-coloured topstitching catches the eye straight away, while the 3-spoke multifunction sports steering wheel with twelve buttons is trimmed in leather with

a two-tone look, the lower section being finished in porcelain-coloured leather. The surface is perforated so that it is even easier to grip. This style is consistently matched by the trim, which is also in a porcelain colour but with a piano lacquer look. The armrests, the door panelling, the shift/selecter lever gaiter and the

centre console are accentuated by contrasting topstitching in a porcelain colour, while the floor mats have porcelain-coloured edging. The Style package can also be further individualised for the ultimate in personalisation.



The Style package individualises the interior of the new C-Class Coupé



All the details combine to paint an impressive overall picture: the porcelain-coloured trim shines with a piano-lacquer look



Gearshift gaiter with contrasting topstitching in porcelain colour

Upholstery and trim



The seat upholstery in ARTICO man-made leather/fabric in black, included as standard, adds the perfect finishing touches to the Coupé's seats. The 3-spoke multifunction steering wheel is trimmed in nappa leather, while the roof lining is finished in alpaca grey fabric. The A-, B- and C-pillars are likewise in alpaca grey. Black is the colour used for the dashboard, the load compartment cover and the door panelling. A black piano lacquer-look trim tastefully rounds off the interior design. The trim for the dashboard, centre console and doors is also optionally available in dark brushed aluminium or matt brown ash.

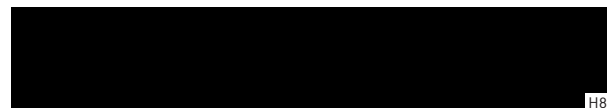

BLACK

721 ARTICO man-made leather/fabric

TRIM

H80 High-gloss black piano lacquer look

739 Dark brushed aluminium¹

H06 Matt brown ash wood¹

¹ Optional extra



The seat upholstery in ARTICO man-made leather/fabric in alpaca grey, included as standard, adds the perfect finishing touches to the Coupé's seats. The 3-spoke multifunction steering wheel is trimmed in nappa leather, while the roof lining is finished in alpaca grey fabric. The A-, B- and C-pillars and the door panelling are likewise in alpaca grey. The "split" dashboard is finished in black and alpaca grey, while the load compartment cover is black. A black piano lacquer-look trim tastefully rounds off the interior design. The trim for the dashboard, centre console and doors is also optionally available in dark brushed aluminium or matt brown ash.

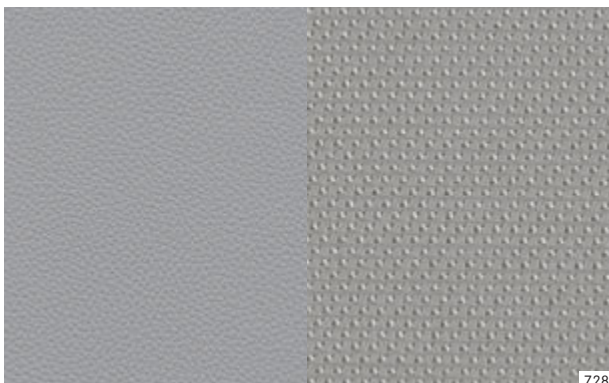

728



H80



739



H06

ALPACA GREY

728 ARTICO man-made leather/fabric

TRIM

H80 High-gloss black piano lacquer look

739 Dark brushed aluminium¹H06 Matt brown ash wood¹

¹Optional extra

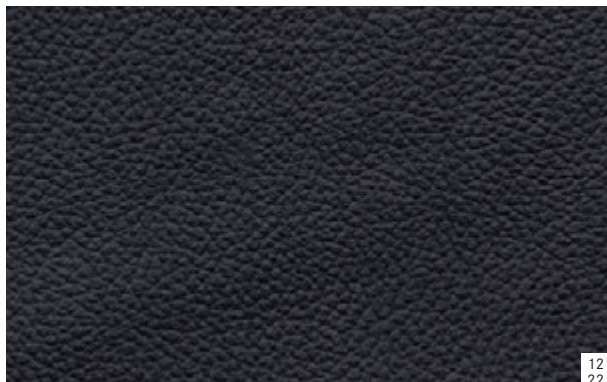

At the heart of the optional black colour scheme are the seats in a choice of black ARTICO man-made leather or black leather with alpaca grey topstitching. The 3-spoke multifunction steering wheel is trimmed in black nappa leather. The door panelling is also kept in black, while the roof lining is finished in black fabric. The A-, B- and C-pillars, the dashboard and the load compartment cover are likewise in black. A dark aluminium trim tastefully rounds off the interior design. The trim for the dashboard, centre console and doors is also optionally available in a high-gloss black piano lacquer look or matt brown ash.

121
221

739

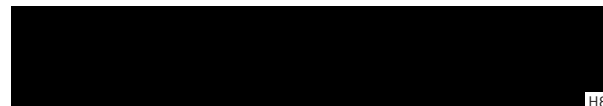

H80



H06

BLACK
121 ARTICO man-made leather¹221 Leather¹

TRIM

739 Dark brushed aluminium

H80 High-gloss black piano lacquer look¹H06 Matt brown ash wood¹

¹ Optional extra

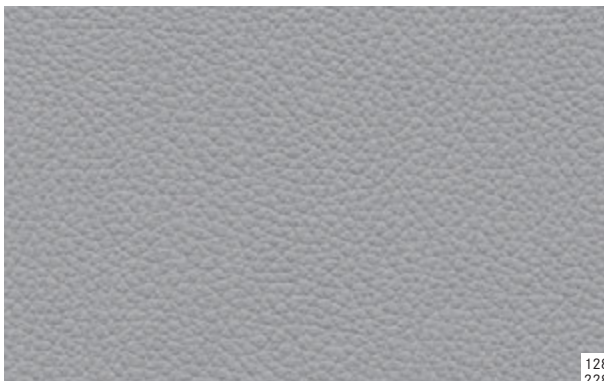

At the heart of the optional alpaca grey colour scheme are the seats in a choice of ARTICO man-made leather or leather in alpaca grey with dark alpaca grey topstitching. The 3-spoke multifunction steering wheel is trimmed in black nappa leather. The door panelling is kept in alpaca grey, while the load compartment cover is in black. The roof lining is finished in black fabric, while the A-, B- and C-pillars are likewise in black. The “split” dashboard is finished in black and alpaca grey. A dark aluminium trim tastefully rounds off the interior design. The trim for the dashboard, centre console and doors is also optionally available in a high-gloss black piano lacquer look or matt brown ash instead of aluminium.

128
228

739

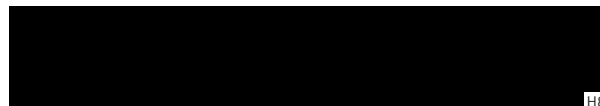

H80



H06

ALPACA GREY

128 ARTICO man-made leather¹228 Leather¹

TRIM

739 Dark brushed aluminium

H80 High-gloss black piano lacquer look¹H06 Matt brown ash wood¹

¹Optional extra



At the heart of the optional sahara beige colour scheme are the seats in sahara beige leather with topstitching in the same colour. The 3-spoke multifunction steering wheel is trimmed in black nappa leather. The door panelling is kept in sahara beige, while the roof lining is finished in black fabric. The A-, B- and C-pillars, the dashboard and the load compartment cover are likewise in black. A dark aluminium trim tastefully rounds off the exclusive interior design. The trim for the dashboard, centre console and doors is also optionally available in a high-gloss black piano lacquer look or matt brown ash.



235



739

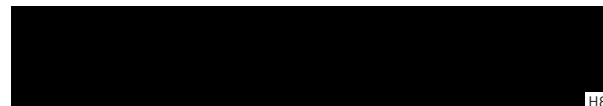

H80



H06

SAHARA BEIGE

235 Leather¹

TRIM

739 Dark brushed aluminium

H80 High-gloss black piano lacquer look¹H06 Matt brown ash wood¹

¹ Optional extra



At the heart of the optional flamenco red colour scheme are the seats in flamenco red leather with black topstitching. The 3-spoke multifunction steering wheel is trimmed in black nappa leather. The door panelling is kept in flamenco red, while the roof lining is finished in black fabric. The A-, B- and C-pillars, the dashboard and the load compartment cover are likewise in black. A dark aluminium trim tastefully rounds off the interior design. The trim for the dashboard, centre console and doors is also optionally available in a high-gloss black piano lacquer look or matt brown ash.

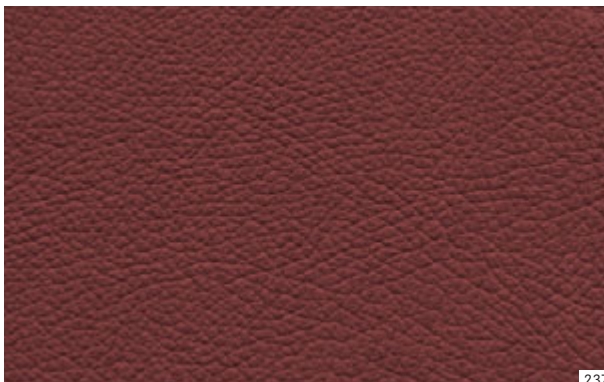

237



739

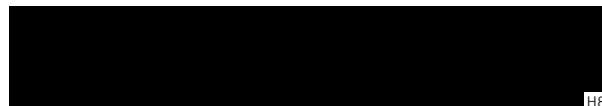

H80



H06

FLAMENCO RED

237 Leather¹

TRIM

739 Dark brushed aluminium

H80 High-gloss black piano lacquer look¹H06 Matt brown ash wood¹

¹Optional extra

Wheels



5-spoke light-alloy wheels in sterling silver with 225/40 R 18 front tyres and 255/35 R 18 rear tyres (optional, Code R36)



7-spoke light-alloy wheels with 195/60 R 16 tyres (standard for C 180 BlueEFFICIENCY, Code R20) or 205/55 R 16 tyres (standard for C 220 CDI BlueEFFICIENCY, Code R75)



7-twin-spoke light-alloy wheels with 205/55 R 16 tyres (optional, not available for C 350 BlueEFFICIENCY, Code R27)



10-spoke light-alloy wheels with 225/45 R 17 tyres (standard for C 250 CDI BlueEFFICIENCY, C 250 BlueEFFICIENCY and C 350 BlueEFFICIENCY, Code 25R)



5-twin-spoke light-alloy wheels with 225/45 R 17 front tyres and 245/40 R 17 rear tyres (optional, Code R95)



Multi-spoke light-alloy wheels with 225/45 R 17 front tyres and 245/40 R 17 rear tyres (optional, Code 56R)



7-spoke AMG light-alloy wheels with 225/40 R 18 front tyres and 255/35 R 18 rear tyres (standard wheels for AMG Sports package, Code 782)



5-twin-spoke AMG light-alloy wheels, painted titanium grey with a high-sheen finish, with 235/40 R 18 front tyres and 255/35 R 18 rear tyres (standard for C 63 AMG, Code 795)



5-spoke AMG light-alloy wheels, painted titanium grey with a high-sheen finish, with 235/40 R 18 front tyres and 255/35 R 18 rear tyres (optional for C 63 AMG, Code 790)



5-spoke light-alloy wheels with 225/45 R 17 front tyres and 245/40 R 17 rear tyres (optional, Code 639)



5-twin-spoke AMG light-alloy wheels with 225/40 R 18 front tyres and 255/35 R 18 rear tyres (optional, Code 786)



Multi-spoke AMG light-alloy wheels, painted titanium grey with a high-sheen finish, with 235/35 R 19 front tyres and 255/30 R 19 rear tyres (optional for C 63 AMG, Code 788)



Multi-spoke AMG light-alloy wheels, painted matt black, rim flange with a high-sheen finish, with 235/35 R 19 front tyres and 255/30 R 19 rear tyres (optional for C 63 AMG, Code 797)



Basic carrier bars and Mercedes-Benz roof box – with a choice of two sizes

Genuine accessories

The new C-Class Coupé is a special car. The extensive range of Mercedes-Benz genuine accessories enables you to add further high-quality individuality.

With genuine accessories from Mercedes-Benz, the new C-Class Coupé can be made to reflect its owner's personal lifestyle. Those who like to travel with lots of luggage or sports equipment can add further stowage space by opting for the reliable and flexible carrier system and a 450 roof box which is easy to load and unload. The roof box is available in a choice of two sizes: the family box which holds around 450 litres or the sports box with a capacity of around 330 litres.

Both boxes can be opened on both sides. Optional extras include a luggage set and a ski rack attachment.



Roof rack with "Luxury" ski and snowboard rack

A car as individual as the new C-Class Coupé greets you every time you get in and out: with white-illuminated Mercedes-Benz lettering on the polished stainless-steel door sill panels.

Thanks to their distinctive styling, the high-end-design incenio light-alloy wheels further emphasise the individual aura of the new C-Class Coupé. These light-alloy wheels are available in a choice of sizes and designs, for example 5-twin-spoke wheels with mixed-size tyres: 225/40 R 18 at the front and, optionally, 255/35 R 18 at the rear.



Illuminated door sill panels with "Mercedes-Benz" lettering

The range of genuine accessories offers a wide selection of high-quality products to choose from. Please see our accessories brochure for further details, or contact your Mercedes-Benz dealer who will be happy to advise you.



incenio 5-spoke light-alloy wheels

Services

Mercedes-Benz Museum. 125 years of automotive history in one place – this is what awaits you at the Mercedes-Benz Museum in Stuttgart. Experience the unique excitement, and embark upon a thrilling journey through time. Housed inside an architecturally impressive building, over 1500 exhibits on nine levels give you an insight into the unique tradition and powers of innovation of the Mercedes-Benz brand. See the world's first two automobiles in the shape of the Benz Patent-Motorwagen (motor car) and the Daimler motorised carriage – both from the year 1886. Two linked circuits take you from the beginnings of the automobile, past a series of unforgettable classics and on to a glimpse of what the future holds – in an area covering a total of 16,500 square metres. Enjoy the unique brand experience. We look forward to your visit. Further details can be found at www.mercedes-benz-classic.com/museum

MercedesCard. The card is your ticket to the Mercedes-Benz experience. Four times a year, we will send you the Mercedes Magazine, featuring fascinating reports from the world of Mercedes-Benz and articles about our latest vehicles. A MercedesCard also has many other uses too. As a VISA credit card, it is an internationally accepted means of payment. Further benefits are available to provide you with peace of mind, such as insurance packages for your Mercedes and other insurance services for the whole family. You also get free entry to the Mercedes-Benz Museum simply by showing your VISA MercedesCard. Further details can be found at www.mercedes-benz.de/mercedescard¹

Mercedes-Benz Financial Services. Mercedes-Benz stands for quality, innovation and safety – and the same applies to Mercedes-Benz Financial Services. Our innovative leasing and financing products are tailored to your financial needs and means, making it easy for you to secure the keys to your dream car. Once you are on the road, our insurance products offer you comprehensive protection on every trip. Finally, our service products ensure that your car is always in tip-top condition whilst keeping costs transparent and easily manageable. For a detailed quotation, please contact your Mercedes-Benz dealer, who will be glad to go through the latest financial services and terms and conditions with you.

Mercedes-Benz mobility. Your new car comes complete with the promise of feeling safe on the road, but if you should ever need assistance, then Mercedes-Benz Service24h is there to help. Just call the freephone service hotline on 00800 1 777 7777². The newly integrated telematics service, Mercedes-Benz Contact³, is even more customer friendly: a touch of a button is all it takes to contact the Mercedes-Benz customer centre. If you wish, the relevant vehicle and position-related data can be transmitted at the same time, thereby allowing the centre to react quickly and provide rapid on-the-spot assistance. Also standard with your new car at no extra charge is the Mercedes-Benz Mobilo⁴ mobility package. Whether you have lost your key, had a breakdown which cannot be repaired immediately or suffered damage to the vehicle due to an accident or vandalism, Mobilo is there to help you reach your destination – anywhere in Europe. Whatever your problem, one thing is certain: you will soon be able to resume your journey.

Service packages. Vehicle-specific services allow you to put together an individual package for your Mercedes, including long-term protection against unforeseeable repair costs and high-quality servicing with genuine Mercedes-Benz parts. You can also count on the extensive network of Mercedes-Benz workshops, where you will receive the usual high standard of service for your Mercedes at a predictable, fixed price. Please ask your Mercedes-Benz dealer for further details.

Test drive. The unique feeling of driving a Mercedes cannot be put into words. Which is why we'd like to invite you to experience it for yourself. Take a test drive and find out first hand how it feels to drive your dream car. Simply visit www.mercedes-benz.com to locate the nearest Mercedes-Benz dealer in your country or region.

Interactive Owner's Manual. The website also offers an interactive tour, enabling you to take a closer look at your desired model. These informative clips are the ideal way to acquaint yourself with your dream car. You can view key functions in detail, gain an insight into the car's inner workings or look at the benefits of each model. For further details, go to: www.mercedes-benz.de/owners-manual

Mobile internet. Now you can access the entire world of Mercedes-Benz from your mobile phone. As well as an overview of all the passenger car models, there are insights into the entire brand world along with a wealth of entertainment offers and direct links to our range of services at www.mercedes.mobi

Dimensions

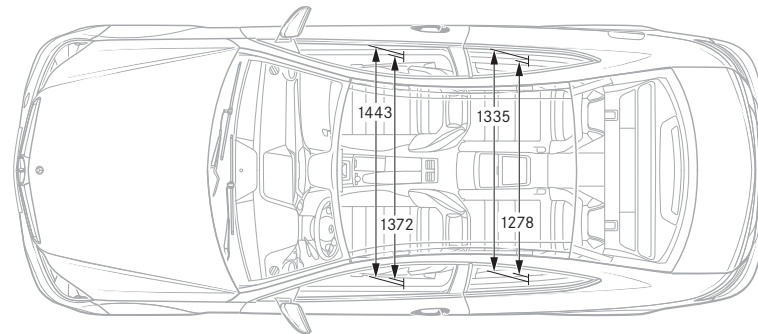
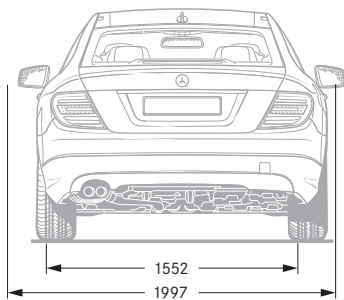
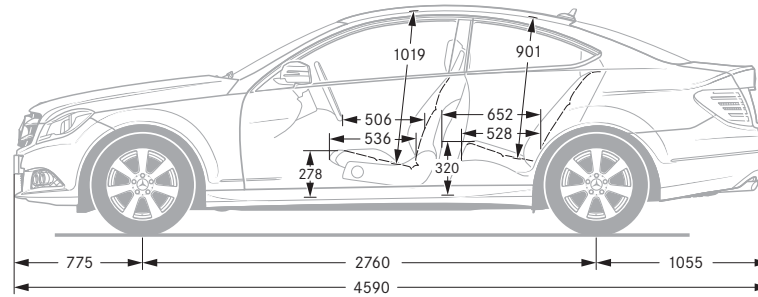
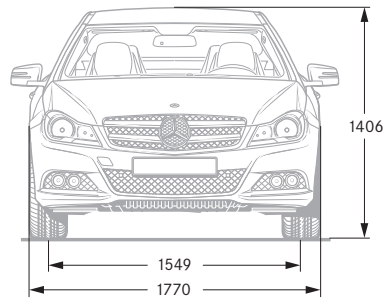

Paintwork

The innovative paint system developed by Mercedes-Benz includes one of the best clearcoats on the automotive market and is a key factor behind the car's excellent value retention. The secret lies in the exceptionally dense molecular structure, which makes both the metallic and the non-metallic clearcoats more resistant and produces a longer-lasting and visibly more intensive shine.

NON-METALLIC PAINTS (standard)

- 040 black
- 590 fire opal
- 650 calcite white

METALLIC PAINTS (optional)

- 183 magnetite black
- 197 obsidian black
- 497 cuprite brown
- 755 tenorite grey
- 775 iridium silver
- 792 palladium silver
- 890 cavansite blue

SPECIAL METALLIC PAINT (optional)

- 799 diamond white BRIGHT

Technical data

No. of cylinders/arrangement
Total displacement (cc)
Rated output ¹ (kW at rpm)
Rated torque ¹ (Nm at rpm)
Acceleration 0-100 km/h (s)
Top speed, approx. (km/h)
Tyre size – front axle, rear axle
Fuel
Fuel consumption ³ (l/100 km)
Urban
Extra-urban
Combined
CO ₂ emissions ³ (g/km) combined
Emissions standard
Tank capacity (l)/incl. approx. reserve
Boot capacity (l)
Turning circle diameter (m)
Kerb weight ⁴ (kg)
Perm. GVW (kg)

DIESEL ENGINES

C 220 CDI BlueEFFICIENCY

4/in-line
2143
125/3000-4200
400/1400-2800
8.4 (8.1)
232 (231)
205/55 R 16
Diesel
5.6-6.3 (6.1-6.5)
3.7-4.3 (4.2-4.6)
4.4-5.1 (4.9-5.3)
117-133 (128-139)
Euro 5
59/8
450
10.84
1615 (1630)
2085 (2100)

C 250 CDI BlueEFFICIENCY

4/in-line
2143
150/4200
500/1600-1800
7.0 (7.1)
240
225/45 R 17
Diesel
6.2-6.8 (6.1-6.5)
4.1-4.6 (4.2-4.6)
4.9-5.4 (4.9-5.3)
128-143 (128-139)
Euro 5
59/8
450
10.84
1655 (1660)
2125 (2130)

¹ Figures according to Directive 80/1269/EEC in the currently applicable version ² Electronically governed ³ The figures shown were obtained in accordance with the prescribed measuring process (Directive 80/1268/EEC in the currently applicable version)
The figures are not based on an individual vehicle and do not constitute part of the product offer; they are provided solely for the purposes of comparison between different vehicle models

	PETROL ENGINES			
	C 180 BlueEFFICIENCY	C 250 BlueEFFICIENCY	C 350 BlueEFFICIENCY	C 63 AMG
No. of cylinders/arrangement	4/in-line	4/in-line	6/V	8/V
Total displacement (cc)	1796	1796	3498	6208
Rated output ¹ (kW at rpm)	115/5000	150/5500	225/6500	336/6800
Rated torque ¹ (Nm at rpm)	250/1600–4200	310/2300–4300	370/3500–5250	600/5000
Acceleration 0–100 km/h (s)	9.0 (8.9)	– (7.2)	– (6.0)	– (4.5)
Top speed, approx. (km/h)	225 (223)	– (240)	– (250) ²	– (250) ²
Tyre size – front axle, rear axle	195/60 R 16	225/45 R 17	225/45 R 17	235/40 R 18, 255/35 R 18
Fuel	Premium petrol	Premium petrol	Premium petrol	Super Plus
Fuel consumption ³ (l/100 km)				
Urban	9.3–9.6 (8.8–9.0)	– (8.8–9.1)	– (9.4–9.6)	– (18.1)
Extra-urban	5.2–5.9 (5.1–5.8)	– (5.2–5.7)	– (5.3–5.6)	– (8.5)
Combined	6.7–7.3 (6.5–7.0)	– (6.5–7.0)	– (6.8–7.0)	– (12.0)
CO ₂ emissions ³ (g/km) combined	157–169 (150–162)	– (152–163)	– (159–164)	– (280)
Emissions standard	Euro 5	Euro 5	Euro 5	Euro 5
Tank capacity (l)/incl. approx. reserve	59/8	59/8	66/8	66/14
Boot capacity (l)	450	450	450	450
Turning circle diameter (m)	10.84	10.84	10.84	11.10
Kerb weight ⁴ (kg)	1500 (1520)	– (1550)	– (1615)	– (1730)
Perm. GVW (kg)	1970 (1990)	– (2020)	– (2085)	– (2160)

⁴ Figures according to Directive 92/21/EC, version 95/48/EC (kerb weight with fuel tank 90% full, driver, 68 kg, and luggage, 7 kg) for standard-specification vehicles

Optional extras and accessories will generally increase this figure and reduce the payload capacity accordingly Figures in brackets refer to engines with an automatic transmission Further technical data can be found at www.mercedes-benz.com

NON-METALLIC PAINTS



METALLIC PAINTS



SPECIAL METALLIC PAINT



Take-back of end-of-life vehicles. Coming full circle. At the end of its long life, you can return your C-Class Coupé to us for environment-friendly disposal in accordance with the EU End-Of-Life Vehicle Directive¹. But that day lies a long way off.

¹ Applies in accordance with national regulations to vehicles up to 3.5 tonnes gross weight. Mercedes-Benz passenger cars have met the statutory regulations governing the suitability of their design for reuse and recycling for a number of years now. A network of vehicle take-back depots and dismantlers has been established which will process your vehicle in an environment-friendly manner. The ways in which both vehicles and parts can be recovered are subject to ongoing development and improvement. Consequently, the C-Class Coupé will be able to comply with any future increases in the recycling quota within the stipulated time limits. For further information: www.mercedes-benz.com

Please note: changes may have been made to the product since this brochure went to press (26.11.2010). The manufacturer reserves the right to make changes to the design, form, colour and specification during the delivery period, provided these changes, while taking into account the interests of the vendor, can be deemed reasonable with respect to the purchaser. Where the vendor or the manufacturer uses symbols or numbers to describe an order or the subject of an order, no rights may be derived solely from these. The illustrations may show accessories and items of optional equipment which are not part of standard specification. Colours may differ slightly from those shown in the brochure, owing to the limitations of the printing process. This brochure is distributed internationally. It provides a general indication of the range of models, features, optional extras, colours and/or services available in various countries. Some of the models, features, optional extras, colours and/or services shown may not be available in your country or may only be available in a different specification. Additionally some models, features, optional extras, colours and/or services may only be available in combination with others. For current and more specific information in relation to the range of models, features, optional extras, colours and/or services available in your country, and their pricing, you should contact your nearest authorised Mercedes-Benz Passenger Car Dealer. www.mercedes-benz.com