

# The B-Class



Mercedes-Benz



who is prepared for everything right from the start: the new B-Class has a particularly interior with high-quality materials has the capacity to make life easier, while the exterior struggle for control of the rear seat. When one pair of eyes is not enough, the new B-Class an early stage if you happen to glance behind you for an instant. Up to ten more assistants d? Its compact exterior fits into just about any parking space, its interior is your second n even be increased with the optional EASY-VARIO-PLUS system. Well-thought-out storage e pairs of short legs in its stride, will still be in great shape by the time their owners a missions, recycle items which can be used again and protect resources. And in case you best  $c_d$  values in its class makes your B-Class that bit greener – irrespective of the pair offer you unrivalled scope for expressing your own distinctive character. Metallic surface insulating glass **For what's coming up.** for the rear and rear side windows is a cool way ons as you do. When a couple gets a couple of new additions, it's good to be able to cou



Families might not be able to plan everything, but they can count on anything happening. The new B-Class meets the demands that daily life has in store for you. Generous amounts of space demonstrate a great sense of order. The confident, sporty exterior and high-quality interior are stylish companions on every journey. Numerous assistance systems pamper you and ease the burden on you or help ensure safety, the standard-specification COLLISION PREVENTION ASSIST being

a case in point. And efficient engines, combined with clever BlueEFFICIENCY measures, make being out on the road as harmless to the environment as possible. Because there's no finer thing than a future. Because you are already thinking of tomorrow today. And because the next generation always has priority. The new B-Class. For what's coming up.

At a glance | from page 4, Insight | from page 20

The models presented:
<b>B 200 CDI BlueEFFICIENCY   polar silver</b>   Cover and from page 2 Night package, Sports package, Exclusive package, light-alloy wheels painted black, hazelnut brown leather, high-gloss black ash wood
<b>B 180 BlueEFFICIENCY   lotus blue</b>   from page 12 Chrome package, 10-spoke light-alloy wheels, Domburg crystal grey fabric, matrix-look

The illustrations may show accessories and items of optional equipment which are not part of standard specification.

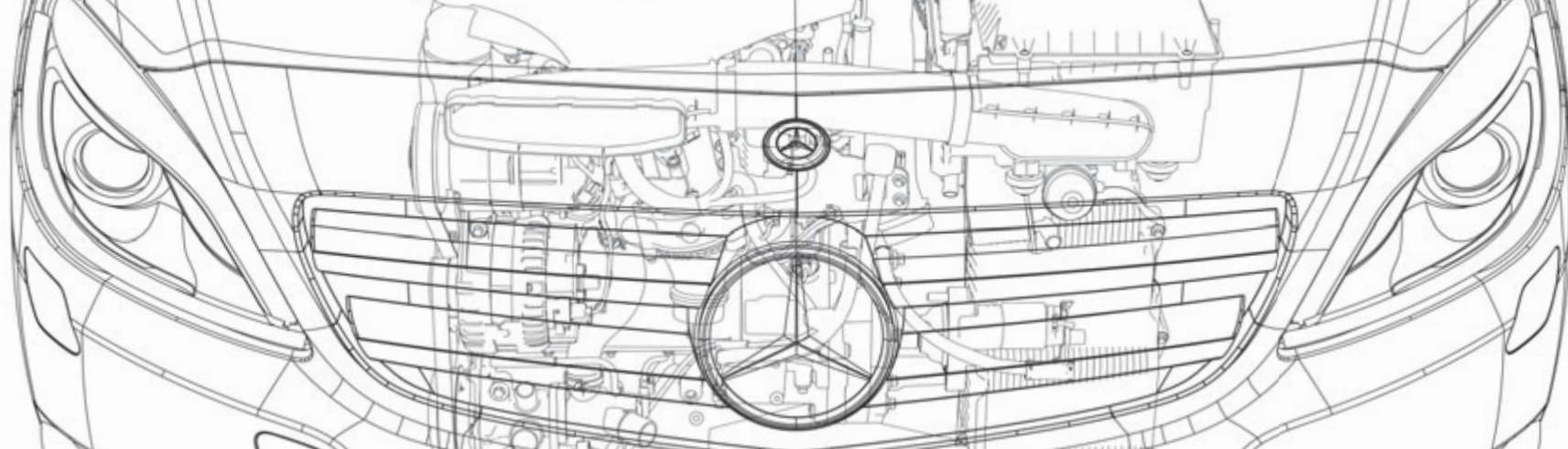

**For driving enjoyment on every road:** BlueEFFICIENCY, diesel and petrol engines, Direct-Steer system and sports suspension.

Drive system & chassis | from page 28

**For arriving safely:** assistance systems which can prevent accidents and minimise the consequences of accidents, such as ATTENTION ASSIST, COLLISION PREVENTION ASSIST, DISTRONIC PLUS and PRE-SAFE®.

Safety | from page 36

**For luxury in everyday life:** standard-specification and optional comfort, such as multimedia and assistance systems, Becker® MAP PILOT, intelligent variability, the Memory package and Light and Sight package.

Comfort | from page 40

**For always having the choice:** generous standard equipment, Chrome, Sports, Night and Exclusive package to meet individual requirements, wheels and genuine accessories.

Equipment & appointments | from page 48

**For the best service:** MercedesCard, Mercedes-Benz Financial Services, Mercedes-Benz mobility, Mercedes-Benz Museum, test drive, Interactive Owner's Manual, mobile internet, service packages, repair following an accident.

Services | from page 72

**For being precise:** technical data, dimensions and paintwork.

Facts & colours | from page 74



## Who says responsibility can't be fun?

When a couple gets a couple of new additions, it's good to be able to count on another member of the family who is prepared for everything right from the start: the new B-Class has a particularly safety-conscious character because it can identify what the road ahead has in store for you at a distance of several metres. Its spacious interior with high-quality materials has the capacity to make life easier, while the exterior impresses with a self-assured face, high-tech headlamps and dynamically sculpted sides.



Five seats.  
And space for a whole family









In front of you, the traffic; behind you, the struggle for control of the rear seat. When one pair of eyes is not enough, the new B-Class has another set on hand: the standard-fit COLLISION PREVENTION ASSIST system keeps looking ahead resolutely to spot hazards at an early stage if you happen to glance behind you for an instant. Up to ten more assistance systems ensure that the new B-Class is a decidedly safe haven for your family. Who says you can't have eyes in the back of your head? → Page 36, 37, 42, 43

I may be looking to the right,  
but I'm looking straight ahead, too



Its compact exterior fits into just about any parking space, its interior is your second home: the new B-Class has a boot whose 486-litre capacity allows it to swallow everything from a pushchair to the weekly shop – and can even be increased with the optional EASY-VARIO-PLUS system. Well-thought-out stowage facilities provide accommodation for every last item. And the back seat, which is able to take sustained punishment from up to three pairs of short legs in its stride, will still be in great shape by the time their owners are teenagers. → Page 44, 45







Green now comes in  
jupiter red and lotus blue too

With the new B-Class you can already take care of lots of things you can do for tomorrow, such as save fuel and reduce emissions, recycle items which can be used again and protect resources. And in case you don't think that the standard-specification BlueEFFICIENCY measures – such as the ECO start/stop function – go far enough, one of the best  $c_d$  values in its class makes your B-Class that bit greener – irrespective of the paint colour you've chosen. → Page 28, 29





What tomorrow will bring? I'd rather know  
what's round the next bend







Of course I can also do the ten kilometres on the treadmill.  
It's just that the new B-Class makes me look so much better





Wherever you go in the new B-Class, you go in style. Four fine equipment packages and additional optional extras offer you unrivalled scope for expressing your own distinctive character. Metallic surfaces in fine silver chrome exude self-assurance, painstaking attention to detail creates an ambience of wellbeing, dark-tinted heat-insulating glass for the rear and side windows is a cool way of giving prying eyes the cold shoulder. With all these possibilities, the new B-Class demonstrates to perfection that good taste has at least as many dimensions as you do. → Page 48-67

There are crashes galore in Sindelfingen – on a daily basis. Hopefully this is the exception out on the roads, but here, in the crash-test hall at Mercedes-Benz, it's just part of normal, everyday life: minor accidents, major accidents, accidents from the front, from behind, from the side and from above.

Because, in order to ensure that there's a happy ending for Mercedes drivers wherever possible if the worst should come to the worst, our engineers carry out a schedule which involves pushing prototypes against the wall 500 times a year in meticulously prepared laboratory tests. During this process it has been known for the sheer strength of the impact to press the paint into the concrete like a fingerprint. But crash tests represent merely the most spectacular part of Daimler's safety philosophy. In actual fact we think long and hard about your protection way in advance of the worst-case bang. The COLLISION PREVENTION ASSIST, for instance, monitors the area in front of the vehicle via radar. In use for the first time as standard in a vehicle of its class, this system is able to warn drivers about crashes and rear-end collisions in good time – and, in the ideal scenario, see to it that hazardous situations simply pass you by.





Crash. Boom. And no bangs

A close-up photograph of a person's face, focusing on the mouth and nose. The person's hand is raised, with fingers near their lips, suggesting a gesture of silence or contemplation. The lighting is soft, highlighting the texture of the skin and the natural color of the lips. The background is dark and out of focus.

As of now, this happens in the best of families





Just between the two of us: do your little guests in the rear also sometimes forget that they aren't all alone in the world? When they prepare for their glittering singing career in stop-and-go traffic, generously distribute biscuits all over the rear seat, try out one funny face after another at the pedestrian crossing ... i.e. when they're simply being children?

In the new B-Class it really is easy just to be yourself without being given any funny looks – simply get in and close the door. Because once inside, not only are you welcomed by an interior that has been lovingly designed with great attention to detail and immediately becomes a second home for your entire family; the optionally available dark-tinted rear and rear side windows conceal everything that isn't intended to feed the curiosity of others. With this much privacy there is only one thing left for the public to see: a model family.



Upholstery and trim. In an accident. Metallic paints. Sound system. Petrol engines.  
on. Optional extra. Fuel consumption. Interior. In the event of danger. LED daytime r  
. Dimensions. Standard equipment. Light. Multimedia systems. Drive system. Genui  
ge. Transmission. Surround sound system. Wheels. Interior. Safe driving. CO<sub>2</sub> emiss  
rim. Assistance systems. BlueEFFICIENCY. In an accident. Metallic paints. Petrol en  
d. Chassis & suspension. Optional extra. Fuel consumption. Interior. Airbags. In the  
ours. Climate control. Seats. ESP<sup>®</sup>. Dimensions. Standard equipment. Light. Multime  
ns. Memory package. Transmission. Surround sound system. Wheels. Interior. Accel  
Interior. Services. Safety. Assistance systems. Upholstery and trim. In an accident.  
e driving. Light-alloy wheels. Top speed. Optional extra. Chassis & suspension. Fuel  
amps. Engines. **The facts.** Paintwork. Total displacement. Climate control. Seats. Dim  
sories. Test drive. Equipment & appointments. Light-alloy wheels. Memory package.

28 **BlueEFFICIENCY**29 **B-Class BlueEFFICIENCY**30 **Diesel engines**

4-cylinder

32 **Petrol engines**

4-cylinder

34 **Transmissions**

6-speed manual transmission

7-speed dual clutch transmission 7G-DCT

35 **Chassis & suspension**

Chassis and steering

Sports suspension

Direct-Steer system

36 **Safe driving**

ATTENTION ASSIST

COLLISION PREVENTION ASSIST

ADAPTIVE BRAKE

DISTRONIC PLUS

Lane Keeping Assist/Blind Spot Assist

Intelligent Light System

38 **In the event of danger or in an accident**

PRE-SAFE® system

Airbags

40 **Multimedia systems**

COMAND Online

Audio 20 CD

Becker® MAP PILOT

Harman Kardon® Logic 7® surround sound system

42 **Assistance systems**

Reversing camera

Active Parking Assist, including PARKTRONIC

Speed Limit Assist

44 **Variability**

Rear seats

Load compartment

EASY-VARIO-PLUS system

Load compartment package

46 **Seats and Memory package**

Seats

Seat Comfort package

4-way lumbar support for driver and front passenger

Memory package

47 **Light and Sight package**

# The B-Class in detail

**48 Equipment, incl. upholstery and trim**

Standard equipment  
Chrome package  
Sports package  
Night package  
Exclusive package

**66 Standard equipment****67 Optional extras****68 Wheels**

Standard wheels  
Optional wheels  
Accessory wheels

**70 Genuine accessories**

Rear Seat Entertainment System  
Concertina load sill guard  
Rear-mounted bicycle rack  
Roof boxes

**72 Services**

MercedesCard  
Mercedes-Benz Financial Services  
Mercedes-Benz mobility  
Mercedes-Benz Museum  
Test drive  
Interactive Owner's Manual  
Mobile internet  
Service packages  
Repair following an accident

**74 Dimensions****74 | 77 Paintwork****75 Technical data**

## BlueEFFICIENCY – fast forward to tomorrow



Mercedes-Benz is quicker at getting future technologies to where it matters most: on the road. By the end of 2012, you will have more than 140 Mercedes-Benz models with BlueEFFICIENCY technologies at your disposal, all of which help you reduce your impact on the environment. Our BlueEFFICIENCY concept comprises innovations for efficient mobility as well as optimised processes all the way along the value chain.

**The BlueEFFICIENCY measures – the Mercedes-Benz efficiency package.** This package consists of comprehensive vehicle optimisations which ease the burden on the environment. Each model combines the most efficient engine with intelligent, latest-generation aerodynamic and energy-management measures. Such measures include the ECO start/stop function, which is being made available for an increasing number of models. The BlueDIRECT V6 and V8 petrol engines, which feature in several model series, deliver a much higher power output while reducing fuel consumption by up to 25%.

**BlueTEC – the clean diesel.** A modular emission-control system makes BlueTEC an exceptionally clean diesel technology. As well as removing 95% of the particulate, it also reduces nitrogen oxides by up to 90%. What remains is mainly water and nitrogen.

**HYBRID – petrol and electric drives intelligently combined.** Here the electric motor can be used both for accelerating and for recuperating braking energy, which is stored in the battery. What's more, the ECU shuts off the petrol engine when the speed is below 15 km/h. In this way, a HYBRID implements significant fuel savings.

**BlueTEC HYBRID – clean diesel combined with electric drive.** It marries the benefits of the HYBRID with those of BlueTEC: during braking, the kinetic energy is converted into electrical energy, which can be re-used when required. At the same time, the BlueTEC technology cleans the exhaust gases and removes many of the pollutants. All of which makes the economical diesel power-plant even more efficient and clean.

**Innovative drive systems that break new ground: E-CELL and F-CELL.** We have developed two locally emission-free drive systems which have been produced on a small scale since 2010. The B-Class F-CELL<sup>1</sup> uses hydrogen to produce power for the electric motor, while the A-Class E-CELL<sup>1</sup> draws its energy directly from two lithium-ion batteries.

But that is not all: under the banner “Design for Environment”, we also look at a vehicle's entire lifecycle and work hard to preserve the environment from the planning stage right through to recycling. In addition, we are involved in the development of alternative fuels and carry out research in the field of bionics. Further information about our comprehensive measures can be found at [www.mercedes-benz.com/blueefficiency](http://www.mercedes-benz.com/blueefficiency)

<sup>1</sup> Provisional data: efficiency class: A++

The data are not based on an individual model and do not constitute part of the product offer; they are provided solely for purposes of comparison between different vehicle models

## B-Class BlueEFFICIENCY

The new B-Class's holistic approach combines agility and dynamism with leading-edge efficiency technologies as well as innovative packages of measures aimed at optimising both fuel consumption and emissions.



Every B-Class delivered is a BlueEFFICIENCY model. What's more, the international environmental certificate "Design for Environment" (ISO/TR 14062) attests to its high environmental compatibility, from production and usage right through to end-of-life disposal.

BlueEFFICIENCY incorporates a whole raft of specific measures:

- 1 Ancillary components controlled to save energy
- 2 Adjustable radiator shutter (B 180 BlueEFFICIENCY) and controlled oil pump
- 3 Particularly efficient alternator
- 4 New engines with direct petrol injection; optimised diesel engines
- 5 Refrigerant compressor property
- 6 Optimised aerodynamics. 13% improvement over the predecessor model ( $c_d$  value = 0.26)
- 7 ECO start/stop function
- 8 Current consumption indicator
- 9 All engines comply with the Euro 5 emissions standard
- 10 Reduced rolling resistance on tyres and wheels
- 11 Newly developed dual clutch transmission 7G-DCT<sup>1</sup> (as an option)

<sup>1</sup> In all likelihood available from 1<sup>st</sup> quarter of 2012

## Diesel engines

More economical, cleaner, more powerful: the new B-Class also signals the launch of the current Mercedes-Benz diesel technology. The engines are powerful and quiet. And they impress with their optimised emission and consumption figures.

**4-cylinder in-line engines.** The 4-cylinder diesel engine proves its up-to-the-minute qualities in both output categories: it impresses with a hefty torque and its immediate response, even in the lower engine speed

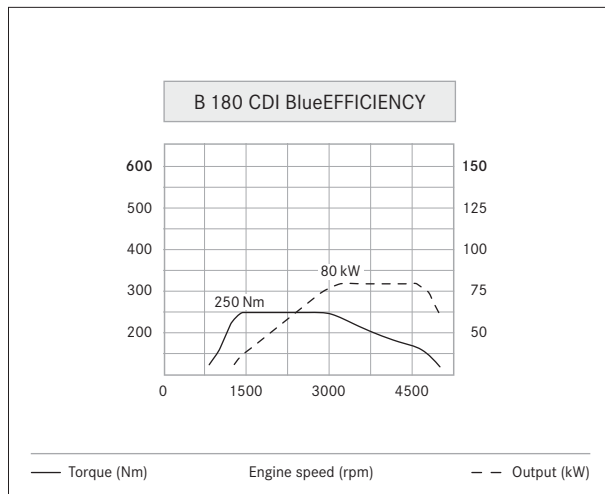

The B 180 CDI BlueEFFICIENCY achieves its maximum torque of 250 Nm at between just 1400 and 2800 rpm

range. At the same time the diesel engines are modest when it comes to fuel consumption, they are low on emissions, impress with their significantly improved quiet-running characteristics and with their reduced vibrations. All this is possible thanks to a whole package of the latest technologies. The fourth-generation common-rail diesel technology boasts an injection pressure that has been increased to 1800 bar, optimised combustion chambers and precise solenoid valve injectors. Improved ignition pressure and a turbocharger with a variable nozzle turbine ensure a high torque in every engine speed range.

Measures such as tyres with low rolling resistance, intelligently controlled ancillaries and optimised aerodynamics all help to raise the efficiency of the vehicle as a whole sustainably. Yet this is by no means all: the current engine generation is characterised by its impressive output and high torque coupled with lower fuel consumption and reduced CO<sub>2</sub> emissions. All

diesel engines have the ECO start/stop function, which ensures that the engine is temporarily switched off when the vehicle is at a standstill.

Both diesel engines comply with the requirements of the Euro 5 emissions standard and are available with the following outputs:

- In the B 180 CDI BlueEFFICIENCY with 1796 cc and 80 kW plus a maximum torque of 250 Nm
- In the B 200 CDI BlueEFFICIENCY with 1796 cc and 100 kW plus a maximum torque of 300 Nm



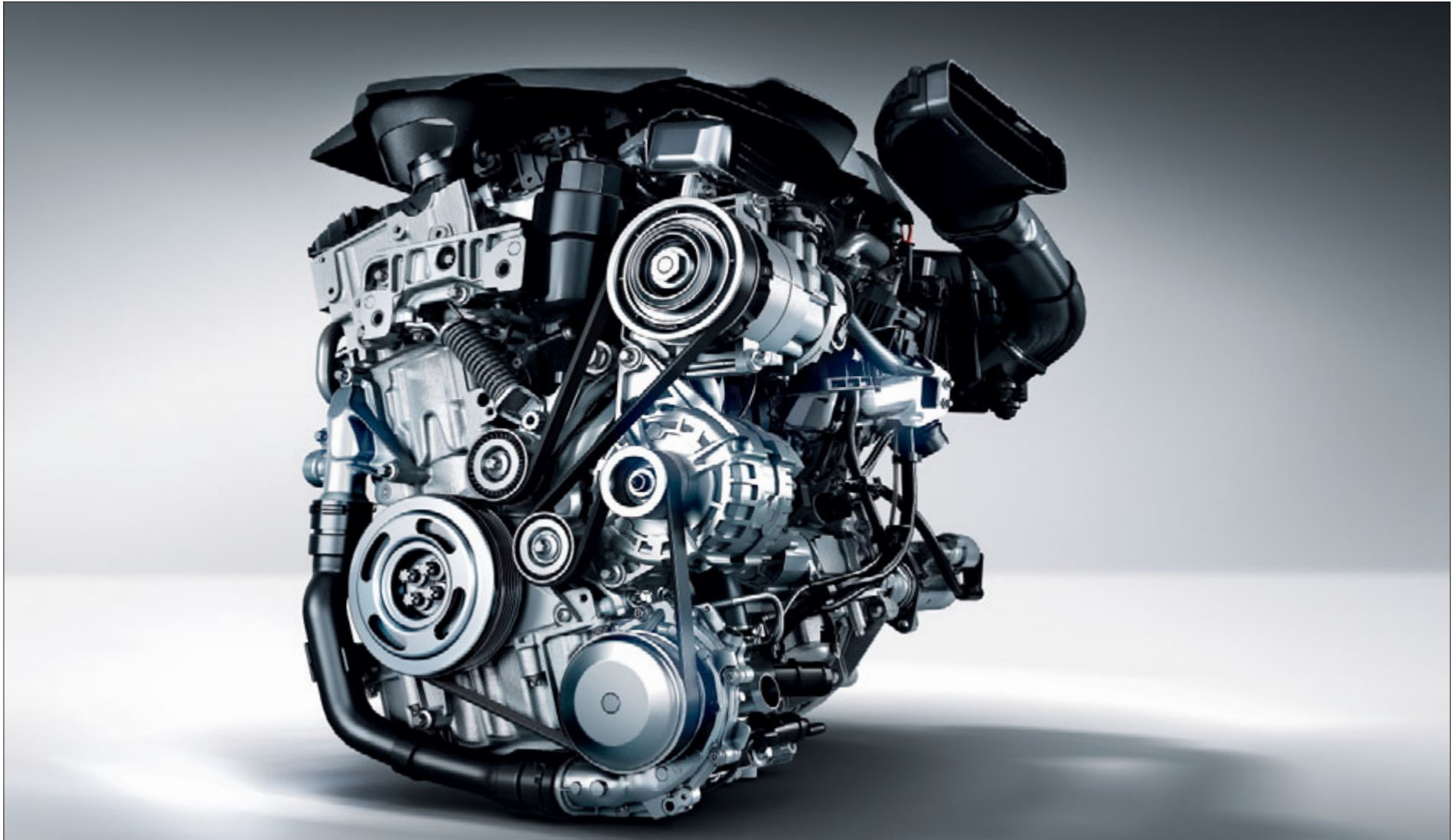

The progressive 4-cylinder diesel engine in the B 180 CDI BlueEFFICIENCY combines pulling power with particularly low consumption and low emissions

## Petrol engines

The new petrol engines were developed with the aim of substantially reducing fuel consumption and emissions without compromising on output and ride comfort. The result: state-of-the-art, trendsetting engine technology.

**4-cylinder in-line engines.** The completely newly developed 4-cylinder powerplant with a displacement of 1.6 litres, direct petrol injection, variable valve timing and a turbocharger offers excellent torque and

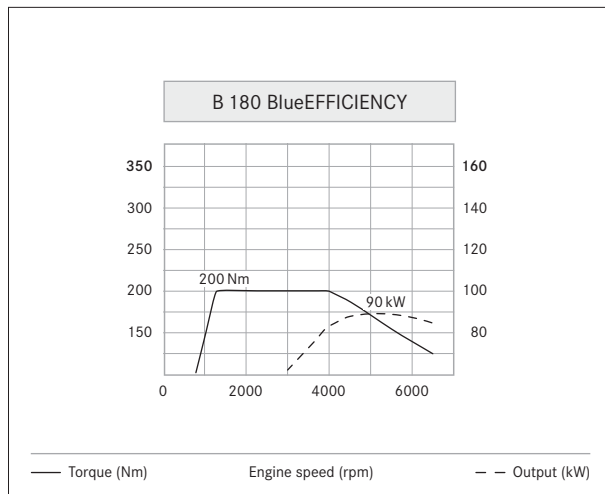

The B 180 BlueEFFICIENCY delivers a peak torque of 200 Nm between 1250 and 4000 rpm

output figures plus exemplary quiet-running characteristics, not to mention appropriately low consumption and emission values.

The high-pressure direct injection via precise piezo injectors and an enhanced combustion process facilitate virtually total combustion and thus higher efficiency, which means that the fuel can be used more efficiently. The variable valve control results in an optimum cylinder charge level and therefore consumption benefits, which also come courtesy of the lower weight, less internal friction plus ancillaries controlled as required. And last but not least the standard-specification ECO start/stop function raises the efficiency of the engines, by automatically switching the engine off when the vehicle is standing at traffic lights or in a jam, thus saving fuel and cutting emissions. Over and above this the new petrol engines include BlueEFFICIENCY measures such as thermal management for an engine warm-up phase that is kept as short as possible, an oil

pump controlled as required plus a particularly efficient alternator.

The 4-cylinder petrol engines come with a choice of two power outputs:

- In the B 180 BlueEFFICIENCY with 1595 cc and 90 kW plus a maximum torque of 200 Nm
- In the B 200 BlueEFFICIENCY with 1595 cc and 115 kW plus a maximum torque of 250 Nm

It goes without saying that both engines comply with the current limit values for consumption and emissions (Euro 5).



The newly developed 4-cylinder B 180 BlueEFFICIENCY petrol engine boasts direct injection via piezo injectors and a turbocharger

## Transmissions

Whether you choose the manual transmission or the innovative 7G-DCT<sup>1</sup> dual clutch transmission, whether you prefer an economical or sporty driving style – both transmissions for the new B-Class are optimally matched to the engine. They set benchmarks where shift comfort, efficiency and weight optimisation are concerned.

**6-speed manual transmission.** All the engines receive a newly developed 6-speed manual transmission and an ECO start/stop function as part of their standard specification. The ECO start/stop function ensures that the engine is temporarily switched off, for example at red traffic lights and in jams. The 6-speed manual transmission impresses with its short and precise shift travel; the engine output, gear spacing and axle final-drive ratio were optimally matched to each other. A display in the instrument cluster gives the driver gearshift recommendations, supporting a particularly efficient driving style.

**7-speed dual clutch transmission 7G-DCT<sup>1</sup> (option).** With seven forward gears and one reverse gear the dual clutch transmission combines comfort, sportiness and economy in unique fashion. It comprises two sub-transmissions which each have their own clutch, with one of these sub-transmissions supporting the “even” gears and the other sub-transmission the “odd” ones. During acceleration or braking the next highest

or next lowest gear is the default setting on the sub-transmission not in use at the time. When changing gear there is then a switchover to the sub-transmission currently not being used. This means that the gear change takes place without any delay or loss of traction. Both the clutch actuation and the gear change occur fully automatically, which is facilitated by particularly smooth gear-shifting without any interruption to traction. The preselectable shift programs “Economy”, “Sport” and “Manual” can be set by the driver via a switch on the centre console. The programs differ from one another with regard to the shift characteristics and shift speed. This means that in “Sport” mode, changing up a gear takes place at higher engine speeds than is the case in “Economy” mode, whilst changing down a gear occurs earlier. The “Manual” mode gives sportily oriented drivers the option of performing gear-shifting both via the selector lever and also manually, via the steering-wheel gearshift paddles which are included in the package too. There is also an integral ECO start/stop function which reduces fuel consumption. In addition

an ergonomic DIRECT SELECT lever and the cruise control and SPEEDTRONIC functions are part of the equipment that comes with the 7G-DCT<sup>1</sup> automated dual clutch transmission.

<sup>1</sup> In all likelihood available from the 1<sup>st</sup> quarter of 2012



The new 7G-DCT<sup>1</sup> enables comfortable gear-shifting without any interruptions in tractive power

## Chassis & suspension

The new B-Class's driving characteristics can be perfectly tuned to individual requirements with the standard-specification configuration of the chassis and steering or with the optionally available combination of the sports suspension and Direct-Steer system.

**Chassis and steering.** Thanks to a weight-optimised combination of the enhanced McPherson strut front axle and totally redesigned four-link rear axle, the completely new chassis facilitates maximum driving stability and high levels of ride comfort. The standard-fit rack-and-pinion steering with the integral steering assistance system STEER CONTROL for support in critical driving situations stands for precise handling. The electromechanical power assistance is reduced as the car's speed increases.

**Sports suspension** (part of the optional Sports package). The sports suspension with its selective damping system blends agility and a high degree of handling safety with good road roar and tyre vibration characteristics. The springs and dampers have more sportily taut tuning than the standard-specification suspension, whilst the level of the car is 15 mm lower, which reduces rolling movements and increases driving stability.

**Direct-Steer system** (part of the optional Sports package). The Direct-Steer system forming part of the Sports package complements the suspension with a variable ratio depending on the steering wheel angle, thus ensuring that the steering movements can implement an even more immediate response on the road. It significantly reduces the steering effort required, in tight bends, for instance, or when parking. The straight-line stability, meanwhile, is especially stable at high speeds and the feedback which the driver receives on the driving situation is particularly precise. Not only does this mean that vehicle agility and steering comfort are improved; the Direct-Steer system also adds up to more driving enjoyment.

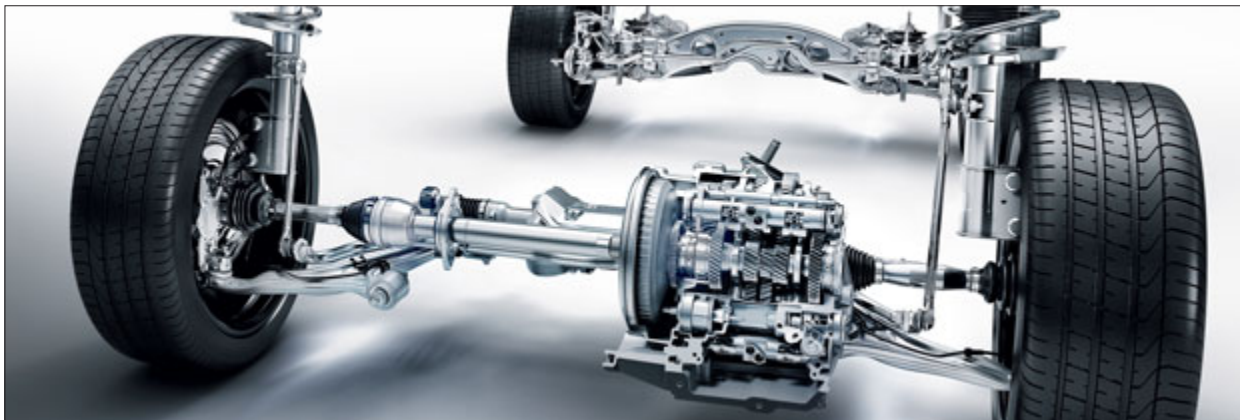

Agility with a high level of comfort – the sports suspension with its selective damping system adjusts the shock absorbers automatically

## Safe driving

The assistance systems in the new B-Class can intervene before an accident happens: thanks to their awareness, even critical situations can be defused – the ideal basis for relaxed driving.

**ATTENTION ASSIST** (standard). This innovative drowsiness-detection system can be especially useful on long trips. At speeds of between 80 and 180 km/h, ATTENTION ASSIST warns the driver as soon as it detects typical signs of drowsiness or inattention. What lies behind this is sensors which analyse steering behaviour and can detect deviations from a previously determined, individual driver profile.



If ATTENTION ASSIST detects signs of driver drowsiness or inattention, it recommends taking a break

**COLLISION PREVENTION ASSIST** (standard). At speeds of more than 30 km/h the system is able to detect when distances between the vehicle in which it is fitted and those in front or stationary obstacles are too short. If a hazard is detected the driver is given both visual and acoustic warnings. During simultaneous braking the Adaptive Brake Assist can place at the driver's disposal precisely the amount of braking power which is required to prevent an impending collision wherever possible.



The COLLISION PREVENTION ASSIST can provide visual and acoustic warnings if the safety margin is too short

**ADAPTIVE BRAKE** (standard). A driving dynamics control system with a modular structure. It offers additional safety and comfort functions alongside a base function such as the anti-lock braking system (ABS). It improves the vehicle's performance with regard to traction, handling safety and operating comfort and helps the driver to master critical braking manoeuvres. The "dry braking" function helps to remove the film of water from the brake discs – the brake's response time and therefore the stopping distance can thus be reduced. "Priming" ensures that the brake pads are placed against the brake discs as soon as the driver takes their foot off the accelerator pedal quickly. The time gained shortens the response time of the brakes. When moving off on an incline unintended rolling back is prevented during the space of time when the foot is moving from the brake pedal to the accelerator; if you actuate the brake pedal a second time whilst the vehicle is stationary, the HOLD function (only with 7G-DCT<sup>1</sup>) keeps the vehicle at a standstill, even if the driver takes their foot away from the brake pedal.

<sup>1</sup> In all likelihood available from the 1<sup>st</sup> quarter of 2012

**DISTRONIC PLUS** (option). The DISTRONIC PLUS proximity control uses short-range and long-range sensors to maintain the desired safe distance to the vehicle in front. The system operates at between 0 and 200 km/h and is also helpful in city traffic or stop-and-go traffic as the sensors can operate in a range of between 0.2 and 200 metres. The system can automatically slow the vehicle down and also accelerate it again. DISTRONIC PLUS is only available in conjunction with the optional 7-speed dual clutch transmission 7G-DCT<sup>1</sup>.

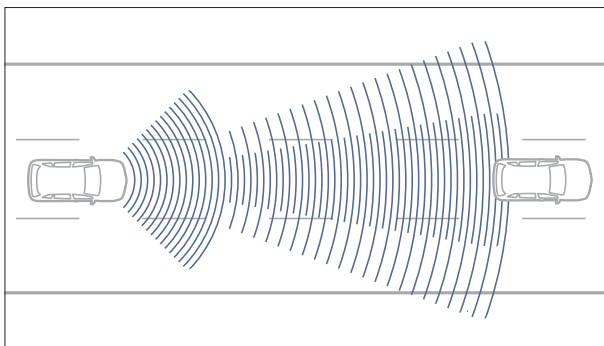

DISTRONIC PLUS supports drivers in automatically keeping their vehicle at a safe distance from the vehicle in front

**Lane Keeping Assist/Blind Spot Assist** (in the optional Lane Tracking package). With the aid of the white lane markings, Lane Keeping Assist can detect a line and through gentle steering-wheel vibrations warn the driver if they are in danger of leaving the lane unintentionally. Blind Spot Assist uses two radar sensors to monitor the area seen poorly by the driver directly alongside and behind the vehicle. If the system detects the danger of an impending collision with another vehicle when changing lanes, the driver can be warned by visual and acoustic signals if the car is travelling at 30 km/h or more.

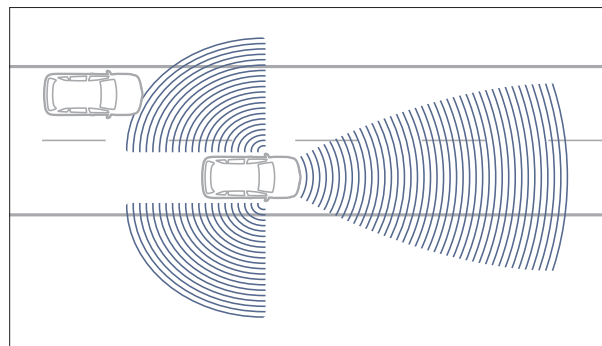

Lane Keeping Assist and Blind Spot Assist can warn the driver in potentially dangerous situations

**Intelligent Light System** (option). The system has six functions: country mode, motorway mode, enhanced fog lamps, cornering light function, active light function and Adaptive Highbeam Assist. The latter provides the best possible low-beam headlamp range. The headlamps can be dimmed automatically as soon as an oncoming vehicle with its lights on is detected. The LED daytime running lamps with a chrome-look insert integrated into the bumper and the LED tail light enhance perceptual safety during the daytime.

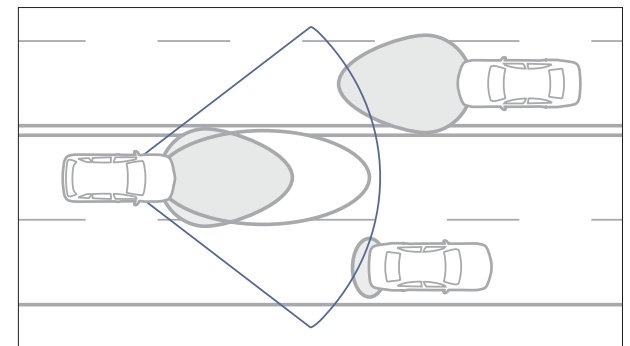

The adaptive Intelligent Light System is an adaptive headlamp system which adjusts automatically to the current weather, light and driving conditions

## In the event of danger or in an accident

Whether there's the danger of an accident or one can no longer be avoided, the new B-Class does all it can to provide better protection for drivers, passengers and pedestrians.

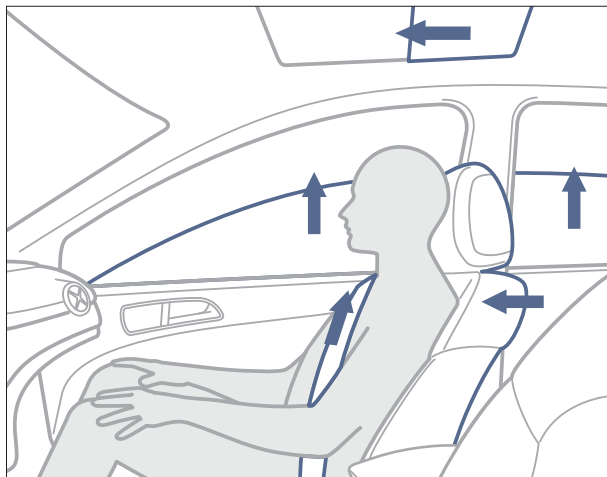

The PRE-SAFE® system can support the protective effect of seat belts and airbags

**PRE-SAFE® system** (option). The preventive occupant protection system PRE-SAFE® is able to recognise critical driving situations in advance and, if necessary, it can activate safety systems which help to reduce the risk of injury to occupants in case they should be needed. This is based on PRE-SAFE® continuously monitoring sensor data from systems like the ESP® and BAS, and can thus, for example, recognise driving situations such as oversteer/understeer as well as emergency braking. If a critical driving situation is detected, in fractions of seconds the belts on the front seats can be reversibly tensioned and the side windows and optional sliding sunroof automatically closed, so that the belts and airbags are able to deploy their full protective effect should an impact occur.

**Airbags** (standard). As well as the robust bodyshell structure and the highly stable occupant cell, there are seven standard-fit airbags to provide the best protection possible for the occupants: the front airbags which are deployed in two stages, depending on the severity of the impact and accident characteristics, windowbags between the A- and C-pillars and pelvis-bags for the driver and front passenger. The kneebag can further reduce the forces exerted on the driver in an accident. Rear sidebags on both sides are available as an option.



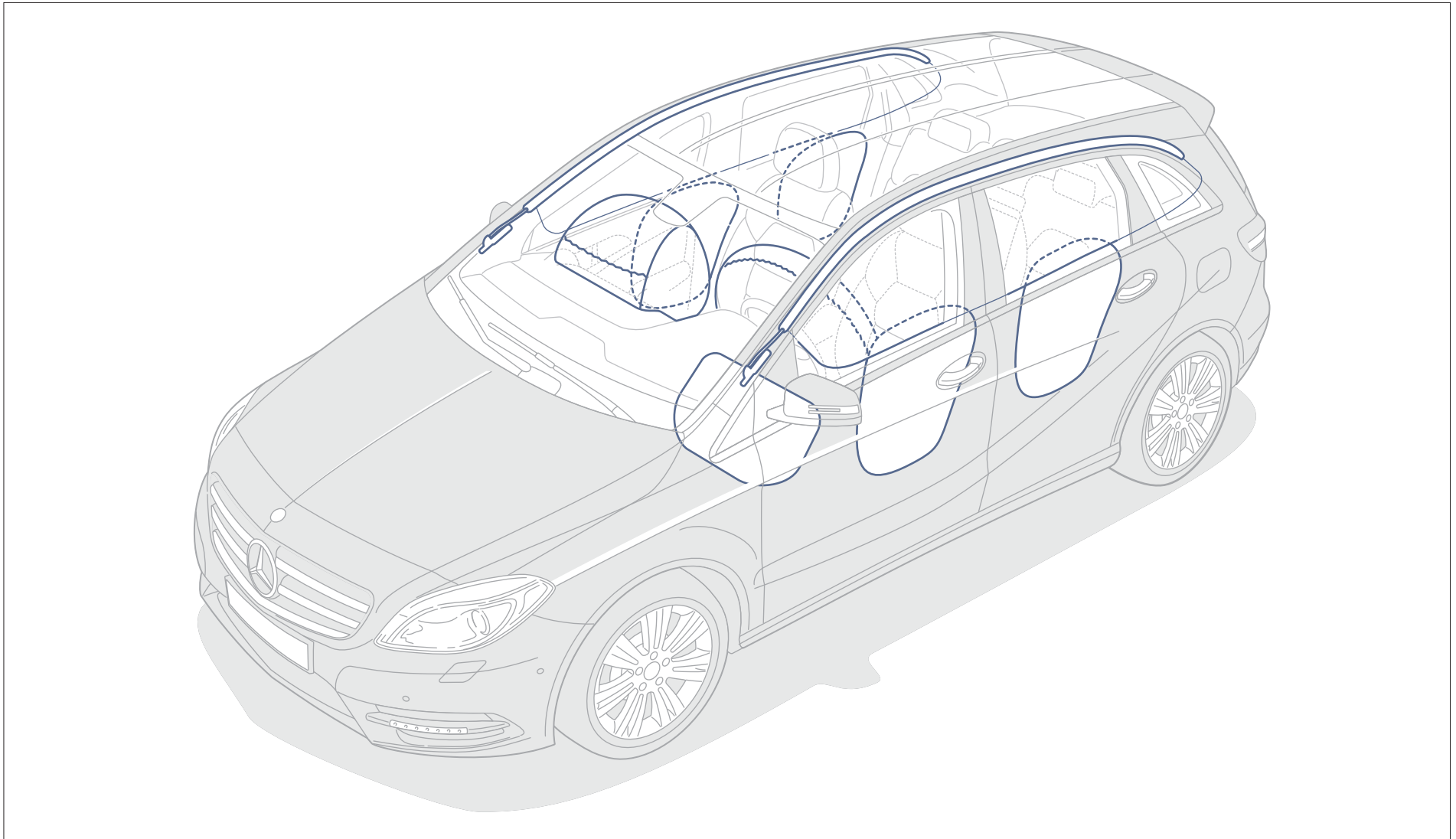

The seven airbags fitted as standard are part of the restraint systems which are decisive in helping to mitigate the consequences of accidents

## Multimedia systems

The new B-Class offers a full range of entertainment, from the Audio 20 and the optional Audio 20 CD system with Becker® MAP PILOT to the optional COMAND Online multimedia system.



COMAND Online facilitates user-friendly operation of the main information and communication functions via a single, high-resolution colour display with a diagonal of 17.8 cm

**COMAND Online** (option). The multimedia system boasts a high-resolution 17.8 cm colour display. The system's functions include a radio, speed-sensitive volume control, the MUSIC REGISTER with a 10-GB hard disc and hard-disc navigation. What's more, for three years from the initial registration it also includes free updates for European map data. The DVD drive plays CDs and MP3 files as well as video and audio DVDs. The online function with an integral browser facilitates access to the internet plus various mobile services from Mercedes-Benz via an internet-capable mobile phone. A USB and an Aux-in socket, a slot for SD memory cards and a Bluetooth® interface enable connections to external data carriers and a mobile phone. The system is operated via a Controller that can be used intuitively and also via the buttons on the multi-function steering wheel. LINGUATRONIC allows you to operate COMAND Online by voice entry.

**Audio 20 CD** (standard). Audio 20 CD ensures that you have an entertaining journey. The Mercedes-Benz multimedia system boasts a display with TFT technology and a 14.7 cm diagonal. With its integral CD drive both MP3 and WMA/AAC files can be played. As an option a 6-disc CD changer can be added to its specification. Audio 20 CD can be conveniently operated via the multifunction steering wheel and the Controller in the centre console, and it includes an integral telephone keypad, a Bluetooth® interface with a hands-free function and an Aux-in and USB socket in the stowage compartment on the centre console. This means that you can easily play music that you have saved on an MP3 player, smartphone or mobile data carrier, for instance. Six loudspeakers bring you pristine listening experiences perfectly tuned to the vehicle's interior.

**Becker® MAP PILOT** (option). Fully integral, the new Becker® MAP PILOT with 3D map navigation can be operated by voice entry via the Controller or the multifunction steering wheel. What's more, it can be individualised in a trice by downloading current map data and additional functions. A cradle for the control unit in the glove compartment allows the system to be used flexibly and to be removed from the vehicle.



The functions provided by the Becker® MAP PILOT are indicated on the Audio 20 CD display and the multifunction display in the instrument cluster

**Harman Kardon® Logic 7® surround sound system** (option). Experience sound that is as realistic, atmospheric and rich in detail as a live performance. With twelve loudspeakers, including a woofer, and a 9-channel DSP amplifier, in conjunction with COMAND Online the 450-watt Dolby Digital 5.1 system ensures an exquisite listening experience. The surround sound playback can be individually tuned to the entire passenger compartment, the front compartment, the centre area or the rear compartment.



The Harman Kardon® Logic 7® surround sound system impresses with its surround sound specially tuned to the interior of the B-Class

## Assistance systems

Alongside numerous safety systems, various convenience assistance systems are also available for the new B-Class for the first time. They can provide the driver with timely warnings of potentially critical situations, helping them avoid dangers.

**Reversing camera (option).** The reversing camera with a wide-angle lens and guide lines provides additional support for the driver by filming the area directly behind the car and sending the images to the screen of the Audio 20 CD (or, on request, of the COMAND Online display). It is activated when reverse gear is engaged, thus enhancing safety when reversing into a parking space.



During parking, the COMAND Online central display shows the area behind the car

**Active Parking Assist, including PARKTRONIC (option).** With the active Parking Assist from Mercedes-Benz the vehicle looks for a suitable parking space by itself at a speed of up to 35 km/h. As soon as the driver confirms a suggestion for a parking space and engages reverse gear, the active Parking Assist automatically parks the car at the press of a button. The driver then only needs to actuate the gearshift, the accelerator and brake pedal. The active Parking Assist deals with



The display in the instrument cluster gives you a clear picture of what is happening when parking

the steering on its own. The system works extremely precisely: for the automatic parking procedure the parking space has to be just 1.30 metres longer than the vehicle. The PARKTRONIC's ultrasonic sensors measure the distance from the vehicle at the front and rear during the automatic parking process. The Active Parking Assist system uses a total of ten ultrasonic sensors, six in the front and four in the rear bumper, plus there is an electronic control unit which processes the sensor signals and calculates the optimum route into the parking space.

**Speed Limit Assist** (included with the optional extra COMAND Online). This assistance system can detect speed-limit signs using a windscreen camera and navigation data and display the appropriate symbol in the display on the instrument cluster. If the applicable speed limit changes, the display in the instrument cluster is amended accordingly. To this end, the camera monitors the area in front of the car on a permanent basis and filters out round traffic signs, be they speed-limit

signs at the side of the road or on a gantry above the road. To detect the signs, the system also scans the data stored on the navigation system's digital map, thus also enabling the identification and display of the signs seen when entering or leaving some towns and villages. Speed Limit Assist is especially helpful on routes with variable speed limits or road works, where Speed Limit Assist helps the driver to keep to the respective maximum speed stipulated, making a tangible contribution towards improving comfort on long journeys when the speed limits are frequently changing.



The Speed Limit Assist can remind the motorist about the speed limit currently in force

## Variability

The rear seats and load compartment are configured to meet a whole host of requirements, making a major contribution to the new B-Class's variability and flexibility.

**Rear seats.** With its standard equipment the rear compartment impresses with the generous amount of legroom it offers. As part of the standard specification the rear seats come with three head restraints, with the centre head restraint restricting the rearward vision as little as absolutely possible. ISOFIX child seat attachments with TopTether securing points are fitted to the backrests of the outer seats. As an optional extra the two outer rear seats are available with integral child seats and a removable lateral support headrest.



The interior can be transformed into a virtually flat load area in just a few simple steps

**Load compartment.** If required the rear seat backrests can be folded in a ratio of 1/3 : 2/3, giving a stowage compartment of up to 1545 litres with a 1.57-metre-long, virtually flat load compartment area. When using the B-Class as a 5-seater the load compartment capacity is 486 litres, and the load compartment floor is adjustable to two levels in conjunction with the optional load compartment package. These functions are rounded off by a load compartment cover plus bag hooks and four load retainers for securing luggage.



In the upper position the optionally available height-adjustable load compartment floor contains a generous stowage compartment

**EASY-VARIO-PLUS system (option).** The separate longitudinal slidability of the rear seat elements and rear seat backrests with tilt angle adjustment ensure more kneeroom or an enlarged load compartment, depending on requirements. There is also a folding armrest in the rear including a through-loading feature, plus two cup holders and a folding front passenger backrest – and it can all be operated quickly and easily.

**Load compartment package (option in conjunction with EASY-VARIO-PLUS system).** This comprises a load compartment floor whose height can be adjusted to two levels, enabling the load compartment to be adapted to the respective load situation. In addition to the other stowage features a folding box ensures more order and safety in the load compartment, which also boasts a socket (12 V). Plus there is an optional net to form a luggage compartment partition behind the first or second seat row, providing increased occupant protection and reducing the risk of transport damage.



Fully folding down the rear seats allows a load compartment capacity of 1545 litres with a practically flat load bay

## Seats and Memory package

Completely new modular seats that meet an exceptionally wide range of requirements in terms of ergonomics, seating comfort and safety have been developed for the new B-Class.

**Seats (standard).** The seats for the new B-Class boast high levels of seating comfort for the front and rear occupants, offering a generous amount of space for their legs and shoulders. The driver's seat is height-adjustable as standard, for optimum adaptation to body size. The modern interior with the high-quality appeal of its materials sports a uniform look in black Venlo fabric, and there are other colours available to please various tastes – in conjunction with a range of optional packages, including seat covers in Domburg fabric, a combination in ARTICO man-made leather/Den Helder fabric plus upholstery in ARTICO or fine leather all over.

**Seat Comfort package (option).** This also comprises height adjustment for the front passenger seat plus seat cushion inclination adjustment for both front seats. Numerous possibilities for ergonomic individualisation and adjustment to the preferred seat position equal yet more seating comfort – above all on longer journeys. The seats with the Seat Comfort package are also characterised by a special seat cushion design.

**4-way lumbar support for the driver and front passenger (option).** The backrest curvature can be individually adjusted to meet the needs of the driver and front passenger, promoting an ergonomic seating position. Two air cushions are integrated in the backrests of both front seats. Via two control valves they can be inflated or deflated as required, facilitating individually tailored support for the lumbar spine. The height of the air cushions is also adjustable.



The comfortable front seats in the B-Class impress with their ergonomics and wide-ranging adjustment options

**Memory package (option).** As an option the driver's seat can be continuously electrically adjusted. The Memory package can store three individual settings for the position of the driver's seat, head restraint and exterior mirrors. With this feature all the seat and backrest settings, the head-restraint height and exterior-mirror position on the driver's and front-passenger side can be called up at all times at just one push of a button, and the front-passenger mirror automatically lowers when reverse gear is engaged.



The Memory package with its fully electrically adjustable driver's seat stores up to three individual settings



## Light and Sight package

The optionally available Light and Sight package highlights the interior design to practical and stylish effect in equal measure, providing a shining example of the comfort and safety standards which prevail in the new B-Class.

**Light and Sight package** (option). The Light and Sight package enhances safety and improves the driver's perception of the traffic – an invaluable benefit in particular during darkness or in poor weather conditions. The package comprises safety-relevant features such as windscreen wipers fitted with a rain sensor and an enlarged washer fluid reservoir, exit and warning lamps for the driver's and front-passenger door, plus a

warning and ambient lamp for the tailgate. Quite apart from the safety aspects, the package also increases the high-class appeal of the interior. The integral ambient lighting in the trim on the dashboard and the door shells and door pulls also lends the interior design of the B-Class a stylish and exclusive touch. This pleasant overall impression is enhanced by sun visors with an illuminated vanity mirror, illuminated interior mirror,

footwell lighting for the driver and front passenger, separately controllable reading lamps on both the left- and right-hand side in the rear – and, last but not least, by a downlighter for the rear compartment. Because seeing and being seen is a matter of both safety and comfort in the new B-Class.



In darkness the ambient lighting stylishly emphasises the interior



The warning and ambient lamp in the tailgate

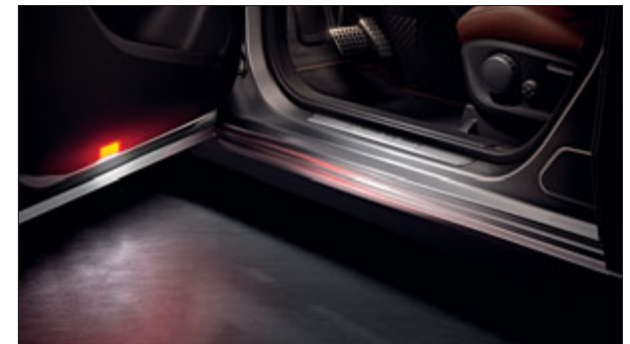

The footwell lighting and the exit and warning lamps



The illustration shows optional extras: metallic paintwork, 10-spoke light-alloy wheels and front fog lamps

## Standard equipment

Luxury is there to be enjoyed every day. Not only is the new B-Class generously designed; it impresses with high functionality and suitability for everyday use plus a modern interior with quality materials. The standard specification includes Audio 20 CD, including Bluetooth®, a USB interface and an Aux-in socket, plus the Controller on the centre console. The standard-fit air conditioning also contributes to a good atmosphere on board at all times. Innovative assistance systems like COLLISION PREVENTION ASSIST and ATTENTION ASSIST round off the extensive range of standard equipment.

---

### EXTERIOR

Headlamp Assist with automatically activated headlamps

Heated exterior mirrors left and right, electrically adjustable from inside and painted in the vehicle colour, with integral indicator lamp

LED daytime running lamps, circular

---

### INTERIOR

12-button 3-spoke multifunction steering wheel

Chrome-design key

Dual-tone horn

ECO start/stop function

Electric parking brake

Front armrest, longitudinally adjustable

Glove compartment illuminated

Power windows (4)

Trim in silver chrome

Trip computer in the multifunction display

---





The seat covers come with Venlo fabric in black as standard. Domburg fabric or ARTICO man-made leather are available as an option, for which there are two upholstery colours each (three in the case of ARTICO) – also featured on the door centre panels and the arm-rest between the front seats. The rest of the interior boasts a coordinated colour scheme, in a combination of lava black with a black carpet. The trim sports a modern matrix-look and can also be selected in finely grained satin-finish brown burr walnut wood or high-gloss black ash wood.

---

**VENLO FABRIC**

---

001 black

---

**DOMBURG FABRIC (option)**

---

011 black

018 crystal grey

---

**ARTICO (option)**

---

101 black

105 sahara beige

108 crystal grey

---

**TRIM**

---

736 High-gloss black ash wood (option)

H03 Satin-finish brown burr walnut wood (option)

H88 Matrix-look

---



001



011



101



105

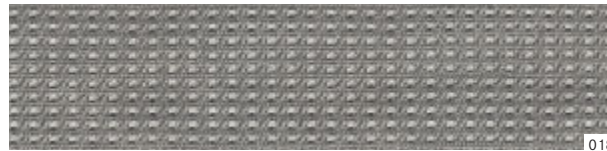

018



108



736



736



736



H03



H03



H03



H88



H88



H88



The illustration shows optional extras: metallic paintwork, 7-twin-spoke light-alloy wheels and bi-xenon headlamps

## Chrome package

Available as an option, the Chrome package enhances the vehicle's high-class appeal with some individual highlights. Shining examples of this on the exterior are the radiator grille trim in brilliant silver, the side chrome trim, the daytime running lamps with a chrome surround and the tailpipe trim in polished stainless steel. Interior details such as the rotary light switch with a surround in silver chrome lend the new B-Class a decidedly high-quality character.

### EXTERIOR

Chromed load sill guard

Daytime running lamps, circular, with chrome surrounds

Front and rear bumpers with chrome trim, rear bumper with black grained insert

Radiator grille with three louvres in brilliant silver with chrome trim

Shoulderline trim strip in chrome

Tailpipe trim in polished stainless steel

### INTERIOR

Armrests with topstitching on the centre console and in the doors

Controller on the centre console with surround in silver chrome

Load compartment floor handle: die-cast zinc in silver chrome

High-gloss rotary light switch with surround in silver chrome

Air outlets with surround and cruciform nozzle in silver chrome

Shift/select lever<sup>1</sup> with highlights in silver chrome

Sun visors illuminated, with vanity mirror

Socket, 12 V, in rear

Trim in matrix-look



<sup>1</sup>In all likelihood 7G-DCT available from the 1<sup>st</sup> quarter of 2012

The upper illustration shows the optional extra THERMOTRONIC luxury automatic climate control.  
The lower illustration also shows optional extras: metallic paintwork and 7-twin-spoke light-alloy wheels



The standard-specification upholstery in Venlo fabric comes in black. The covers are also optionally available in black and crystal grey Domburg fabric, and also in ARTICO man-made leather in sahara beige. The trim is available in a matrix-look or, on request, in finely grained satin-finish brown burr walnut wood or high-gloss black ash wood. The shift lever, ventilation outlets and controls are adorned with trim in fine silver chrome. In the case of the upholstery colours crystal grey and sahara beige the armrests between the front seats and the door centre panels partially feature a two-tone contrast-look with black. The rest of the interior is in lava black.

---

**VENLO FABRIC**

---

001 black

---

**DOMBURG FABRIC (option)**

---

011 black

018 crystal grey

---

**ARTICO (option)**

---

101 black

105 sahara beige

108 crystal grey

---

**TRIM**

---

736 High-gloss black ash wood (option)

H03 Satin-finish brown burr walnut wood (option)

H88 Matrix-look

---



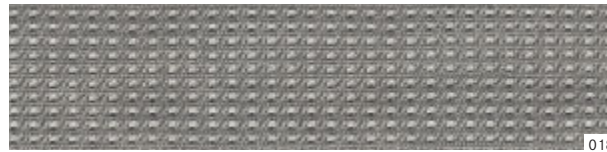



The illustration shows the optional extra bi-xenon headlamps

## Sports package

Driving enjoyment even at a standstill – the decidedly more dynamic and more athletic look which comes courtesy of the Sports package, coupled with increased agility, is evident in many details: exclusive appointments and equipment features, a greater degree of individualisation plus special technical highlights. The contents of the Chrome package are automatically included in the Sports package.

---

### EXTERIOR

5-spoke light-alloy wheels with 225/45 R 17 tyres

Brake discs perforated and internally ventilated at the front, front brake callipers with “Mercedes-Benz” lettering

Radiator grille with twin louvres in brilliant silver with chrome trim

Sports suspension with selective damping system and Direct-Steer system (deselectable)

### INTERIOR

3-spoke multifunction steering wheel in perforated leather

Armrest in ARTICO on centre console with topstitching

Door sill panels front and rear in stainless steel

Headlining in black, deselectable

Seat Comfort package

Seats in ARTICO man-made leather/Den Helder fabric

Shift/selecter lever<sup>1</sup> in leather with highlights in silver chrome

Sports pedals in stainless-steel-look with rubber studs

Trim in honeycomb-look



<sup>1</sup>In all likelihood 7G-DCT available from the 1<sup>st</sup> quarter of 2012

The upper illustration shows optional extras: COMAND Online multimedia system, THERMOTRONIC luxury automatic climate control and automated dual clutch transmission 7G-DCT (in all likelihood available from the 1<sup>st</sup> quarter of 2012)



The Sports package also lends the interior a decidedly dynamic feel. The seat covers can be selected in the combination ARTICO man-made leather/Den Helder fabric in black or crystal grey, and on request completely in black, sahara beige or crystal grey ARTICO. The upholstery colours in ARTICO are featured on the door centre panels and armrests. The dashboard with trim in silver chrome is discreetly coordinated with the chosen interior colour in a tone-in-tone-look. The rest of the interior is colour-matched in a combination of lava black with a lava black carpet. The trim boasts a honeycomb-look, and it is also optionally available in satin-finish brown burr walnut wood or high-gloss black ash wood. The leather-covered, perforated steering wheel is adorned with contrasting topstitching. The roof liner in black can also be deselected as a further option.

---

**ARTICO MAN-MADE LEATHER/DEN HELDER FABRIC**

---

601 black

608 crystal grey

---

**ARTICO (option)**

---

101 black

105 sahara beige

108 crystal grey

---

**TRIM**

---

736 High-gloss black ash wood (option)

H03 Satin-finish brown burr walnut wood (option)

H89 Honeycomb-look

---



601



101



105



608



108



736



736



H03



H03



H89



H89



The illustration shows the optional extra bi-xenon headlamps

## Night package

Drivers are sure to make a cool impression in any situation with the Night package: with its selected exterior equipment the package lends the vehicle unmistakable and mysterious character in fine high-gloss black, whilst the interior corresponds to the scope of the Sports package. Other unique features are the heat-insulating dark-tinted glass for the rear and rear side windows, which gives prying eyes the cold shoulder. The Night package is only available in conjunction with the Sports package and bi-xenon headlamps.



### EXTERIOR

5-twin-spoke light-alloy wheels, painted black with a high-shine finish, with 225/40 R 18 tyres (mandatory in conjunction with Night package)

Bi-xenon headlamps (mandatory in conjunction with Night package)

Bumper without trim

Heat-insulating dark-tinted glass at the rear and rear side windows (from B-pillar)

Radiator grille with twin louvres in high-gloss black with chrome trim

Shoulderline and roof trim strip in high-gloss black

### INTERIOR

Appointments as per Interior Sports package



The illustration above shows optional extras: COMAND Online multimedia system and THERMOTRONIC luxury automatic climate control



The seat covers can be selected in ARTICO man-made leather/Den Helder fabric in black or crystal grey. In addition the interior is also available in black, sahara beige and crystal grey ARTICO. The upholstery colours are featured on the door centre panels and on the arm-rest between the front seats. The rest of the interior is colour-matched in lava black. The trim boasts a sporty honeycomb-look, and is also optionally available in satin-finish brown burr walnut wood or high-gloss black ash wood.

---

**ARTICO MAN-MADE LEATHER/DEN HELDER FABRIC**

---

601 black

608 crystal grey

---

**ARTICO (option)**

---

101 black

105 sahara beige

108 crystal grey

---

**TRIM**

---

736 High-gloss black ash wood (option)

H03 Satin-finish brown burr walnut wood (option)

H89 Honeycomb-look

---







The illustration above shows optional extras: COMAND Online multimedia system, THERMOTRONIC luxury automatic climate control and automated dual clutch transmission 7G-DCT (in all likelihood available from the 1<sup>st</sup> quarter of 2012)

## Exclusive package

The optional Exclusive package represents a classic interior of the highest quality, combined with numerous exclusive appointments and equipment features, the like of which are traditionally found in luxury-segment vehicles. The Exclusive package is available on the basis of the Chrome, Sports or Night package and offers various options for individualisation.

---

### INTERIOR

---

Armrest in ARTICO on the centre console with topstitching, adjustable lengthwise

---

Armrests in ARTICO in the doors with topstitching

---

Cover above stowage compartment in black-painted plastic

---

Dashboard and door centre panels in ARTICO with topstitching

---

Door sill panels front and rear in stainless steel

---

Enhanced central locking system with infrared remote control

---

Floor mats, velours, with edging in appointments colour

---

Front seats with 4-way lumbar support

---

Headlining in black (upholstery hazelnut brown)

---

Headlining in grey (upholstery lava black, crystal grey)

---

Heated front seats

---

High-gloss black ash wood on request at no extra charge

---

Leather steering wheel as 3-spoke steering wheel with 12 function buttons

---

Seat Comfort package

---

Seats in leather upholstery with topstitching

---

Shift/selecter lever<sup>1</sup> and shift lever gaiter in leather, plus shift/selecter lever<sup>1</sup> with surround in silver chrome

---

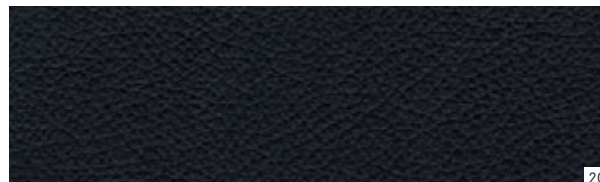

201

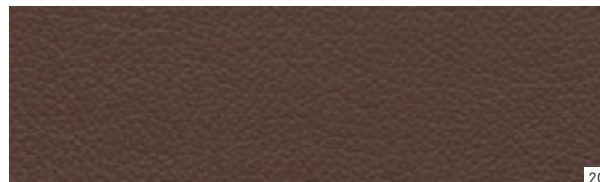

204

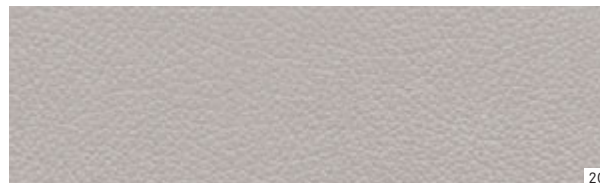

208



736



H03

Enjoying pride of place in the Exclusive package, the seat upholstery in fine leather is available in the colours lava black, hazelnut brown or crystal grey. The selected upholstery colours are also to be found on the door centre panels and on the armrest between the front seats, and in the case of the interior colour crystal grey also on the underside of the dashboard and on the centre console. The dashboard with its chrome trim on the ventilation outlets, controls and shift lever is discreetly coordinated with the chosen interior colour in a tone-in-tone-look. The rest of the interior is colour-matched in lava black with floor mats featuring tone-in-tone edging. The trim is in finely grained satin-matt brown burr walnut wood and is optionally available in fine high-gloss black ash wood.

---

### LEATHER

---

201 lava black

---

204 hazelnut brown

---

208 crystal grey

---

### TRIM

---

736 High-gloss black ash wood (option)

---

H03 Satin-finish brown burr walnut wood

---

<sup>1</sup>In all likelihood 7G-DCT available from 1<sup>st</sup> quarter of 2012

## Standard equipment | Selection



Multifunction steering wheel



Audio 20 CD



Integral aerial



Power windows (4)



THERMATIC air conditioning system



Luggage cover

## Optional extras | Selection



Ambient lighting



Reversing camera



Convenience Telephony



Becker® MAP PILOT



Luxury automatic climate control THERMOTRONIC



Trailer coupling, manually folding

## Wheels



10-spoke steel wheel with wheel trim with 195/65 R 15 tyres (standard for B 180 CDI BlueEFFICIENCY and B 180 BlueEFFICIENCY), Code R00



10-spoke light-alloy wheels with 205/55 R 16 tyres (optional, not available for Sports package or Night package), Code 55R



Steel wheel with 10-hole wheel trim with 205/55 R 16 tyres (standard for B 200 CDI BlueEFFICIENCY and B 200 BlueEFFICIENCY, not available for Sports package or Night package), Code 643



10-spoke light-alloy wheel with 225/45 R 17 tyres (optional, not available for Night package), Code R43



7-twin-spoke light-alloy wheel with 225/45 R 17 tyres (optional, not available for Night package), Code 26R



5-twin-spoke light-alloy wheel, painted black and with a high-sheen finish, with 225/40 R 18 tyres (optional, integral part of Night package), Code 01R



incenio 5-twin-spoke light-alloy wheel, painted himalayas grey, with 225/45 R 17 tyres (accessory, not available for Night package)



5-spoke light-alloy wheel with 225/45 R 17 tyres (integral part of Sports package), Code R24



incenio 5-twin-spoke light-alloy wheel, painted champion silver, with 205/55 R 16 tyres (accessory, not available for Night package)

## Genuine accessories

Practical, diverse, flexible – the genuine accessories open up an extensive raft of opportunities for using the new B-Class even more intensively.

→ [www.mercedes-benz.com](http://www.mercedes-benz.com)



The Rear Seat Entertainment System with its two bright LCD colour screens enhances the enjoyment for your rear passengers

**Rear Seat Entertainment System.** The elegant DVD system puts your DVD videos, favourite pictures and even video games on two bright 17.8 cm LCD colour screens, without disturbing the driver or restricting the rearward field of vision. One of the monitors is fitted with a DVD player, USB and SD card interface, facilitating the use of many other storage media as well as DVDs. The second screen serves as a display monitor. Both can be very easily removed from their holder with one click and can also be used outside the vehicle via the 230 V/12 V power supply unit delivered with the system.

The extensive equipment includes USB and SD card interfaces, two infrared headphones and radio remote control. The monitors are also available individually on request. The Rear Seat Entertainment System does not require any pre-installation at the factory: it can also be used subsequently in your new B-Class.



**Concertina load sill guard.** Loading and unloading the B-Class is a relaxed affair with the new concertina load sill guard made of durable nylon fabric. This component can be attached simply and in a space-saving manner on the floor behind the load compartment sill with Velcro fasteners. The load sill guard is extendable in one simple step to provide extensive protection for the load compartment sill and rear bumper.



The concertina load sill guard protects the rear bumper and the load compartment sill against scratches when loading and unloading

**Rear-mounted bicycle rack.** Convenient, lockable rear-mounted bicycle rack for transporting two or three bicycles safely. Fitting it on the trailer coupling is child's play, and mounting your bikes on the rack is just as easy. Thanks to a clever roll-off mechanism the boot can still be opened. A transport bag made of robust nylon fabric protects your rear-mounted bicycle rack when you want to fold it up and store it for a while.



The rear-mounted bicycle rack for the trailer coupling is available in two versions

**Roof boxes.** The aerodynamic design of the roof boxes, which are made of an extremely durable material, is perfectly matched to the new B-Class. Thanks to the option of opening on both sides, they are especially easy to load and unload. Select from two sizes: the family box in black metallic or matt silver offers a volume of 450 litres, the sports box in titanium metallic or matt silver a capacity of 330 litres.



The roof boxes are available with a capacity of 330 and 450 litres, and each version is available in two colours

## Services

**MercedesCard.** The card is your ticket to the Mercedes-Benz experience. Four times a year, we will send you the Mercedes-Benz Magazine, featuring fascinating reports from the world of Mercedes-Benz and articles about our latest vehicles. A MercedesCard also has many other uses too. As a VISA credit card, it is an internationally accepted means of payment. Further benefits are available to provide you with peace of mind, such as insurance packages for your Mercedes and other insurance services for the whole family. Further details can be found at [www.mercedes-benz.com](http://www.mercedes-benz.com)<sup>1</sup>

**Mercedes-Benz Financial Services.** Mercedes-Benz stands for quality, innovation and safety – and the same applies to Mercedes-Benz Financial Services. Our innovative leasing and financing products are tailored to your financial needs and means, making it easy for you to secure the keys to your dream car. Once you are on the road, our insurance products offer you comprehensive protection on every trip. Finally, our service products ensure that your car is always in tip-top condition whilst keeping costs transparent and easily man-

ageable. For a detailed quotation, please contact your Mercedes-Benz dealer, who will be glad to go through the latest financial services and terms and conditions with you.

**Mercedes-Benz mobility.** Your new car comes complete with the promise of feeling safe on the road, but if you should ever need assistance, then Mercedes-Benz Service24h is there to help. Just call the freephone service hotline on 00800 1 777 7777<sup>2</sup>. The newly integrated telematics service, Mercedes-Benz Contact<sup>3</sup>, is even more customer friendly: a touch of a button is all it takes to contact the Mercedes-Benz customer centre. If you wish, the relevant vehicle and position-related data can be transmitted at the same time, thereby allowing the centre to react quickly and provide rapid on-the-spot assistance. Also standard with your new car at no extra charge is the Mercedes-Benz Mobilo<sup>4</sup> mobility package. Whether you have lost your key, had a breakdown which cannot be repaired immediately or suffered damage to the vehicle due to an accident or vandalism, Mobilo is there to help

you reach your destination – anywhere in Europe. Whatever your problem, one thing is certain: you will soon be able to resume your journey.

**Mercedes-Benz Museum.** Experience 125 years of automotive history against an architecturally impressive backdrop. Over 1500 exhibits on nine levels give you an insight into the unique tradition and powers of innovation of the Mercedes-Benz brand in Stuttgart. See the world's first two automobiles in the shape of the Benz Patent-Motorwagen (motor car) and the Daimler motorised carriage – plus the automotive future of Mercedes-Benz – in an area covering a total of 16,500 square metres. We look forward to your visit – online, too, at [www.mercedes-benz-classic.com/museum](http://www.mercedes-benz-classic.com/museum)

**Test drive.** The unique feeling of driving a Mercedes cannot be put into words. Which is why we'd like to invite you to experience it for yourself. Take a test drive and find out first hand how it feels to drive your dream car. Simply visit [www.mercedes-benz.com](http://www.mercedes-benz.com) to locate your nearest Mercedes-Benz dealer.

<sup>1</sup> Information about the MercedesCard in Austria and Switzerland can be found on the Mercedes-Benz websites for these countries <sup>2</sup> Alternative: +49 69 95 30 72 77. The only charge incurred is the cost of the mobile phone call to the landline network

**Interactive Owner's Manual.** The website also offers an interactive tour, enabling you to take a closer look at your desired model. Experience key functions in detail, gain an insight into the car's inner workings or look at the benefits of each model at [www.mercedes-benz.de/owners-manual](http://www.mercedes-benz.de/owners-manual)

**Mobile internet.** Now you can access the entire world of Mercedes-Benz from your mobile phone. As well as an overview of all the passenger car models, there are insights into the entire brand world along with a wealth of entertainment offers and direct links to our range of services at [www.mercedes.mobi](http://www.mercedes.mobi)

**Service packages.** Vehicle-specific services allow you to put together an individual package for your Mercedes-Benz: for a small monthly premium the Excellent service package covers all service jobs including maintenance, wear and repairs – for up to five years. Simply present your service card and you will be safe from any financial surprises. And you can rely on the fact that your Mercedes-Benz will remain

on top form for a long time to come. With the Advance service package your Mercedes-Benz will stay at its best for longer still: you will be protected against unexpected repair costs even after the manufacturer's warranty or the service package has expired – for up to ten years.

**Repair following an accident.** Should the worst come to the worst, the Mercedes-Benz accident repair service provides you with the best help available for your vehicle,

which will retain its valuable safety properties. From work on the paint to bodywork or glass damage – optimally trained specialists will repair your Mercedes-Benz at your Mercedes-Benz service partner, and you will soon be back on the road again. Further information is available from your authorised Mercedes-Benz dealer.



## Dimensions

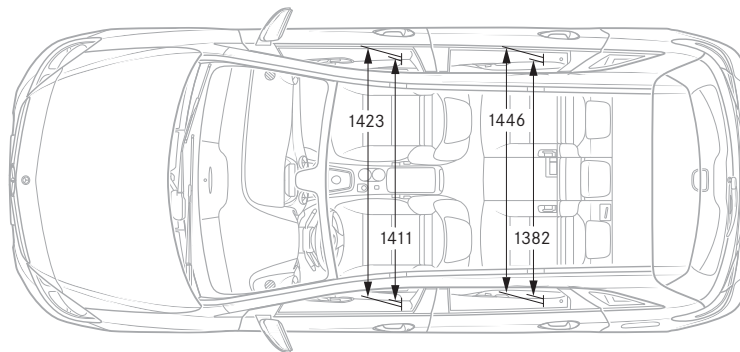
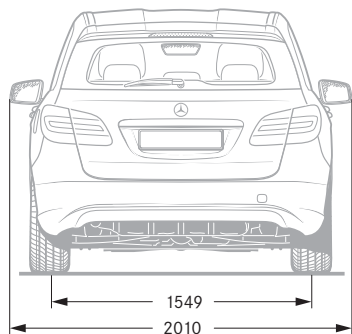
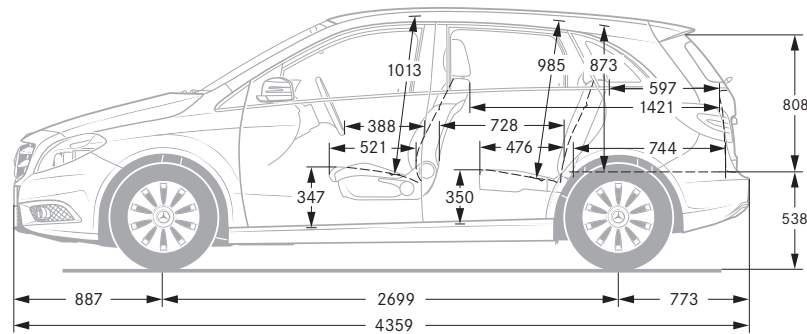
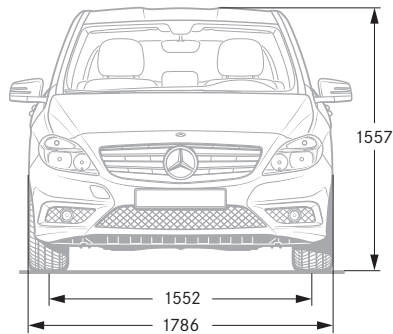

## Paintwork

The innovative paint system developed by Mercedes-Benz includes one of the best clearcoats on the automotive market and is a key factor behind the car's excellent value retention. The secret lies in the exceptionally dense molecular structure, which makes both the metallic and the non-metallic clearcoats more resistant and produces a longer-lasting and visibly more intensive shine.

### NON-METALLIC PAINTS (standard)

- 589 jupiter red
- 650 cirrus white
- 696 night black

### METALLIC PAINTS (option)

- 191 cosmos black
- 240 lotus blue
- 761 polar silver
- 787 mountain grey
- 893 megalith grey
- 894 universe blue
- 895 canyon beige

## Technical data

No. of cylinders/arrangement
Total displacement (cc)
Rated output <sup>1</sup> (kW at rpm)
Rated torque <sup>1</sup> (Nm at rpm)
Acceleration from 0-100 km/h (s) (7G-DCT)
Top speed, approx. (km/h)
Tyre size front axle
Tyre size rear axle
Fuel
Fuel consumption <sup>2</sup> (l/ 100 km)
Urban (7G-DCT)
Extra-urban (7G-DCT)
Combined (7G-DCT)
CO <sub>2</sub> emissions <sup>2</sup> (g/km) combined (7G-DCT)
Efficiency class
Emission class
Tank capacity (l)/incl. approx. reserve
Boot capacity (l)
Turning circle diameter (m)
Kerb weight <sup>3</sup> (kg) (7G-DCT)
Perm. GVW (kg) (7G-DCT)

### DIESEL ENGINES

B 180 CDI BlueEFFICIENCY	B 200 CDI BlueEFFICIENCY
4/in-line	4/in-line
1796	1796
80/3200-4600	100/3600-4400
250/ 1400-2800	300/1600-3000
10.9 (10.7)	9.5 (9.3)
190	210
195/65 R 15	205/55 R 16
195/65 R 15	205/55 R 16
Diesel	Diesel
5.6-5.4 (5.5-5.3)	5.6-5.4 (5.5-5.3)
4.1-3.8 (4.2-3.9)	4.1-3.8 (4.2-3.9)
4.6-4.4 (4.7-4.4)	4.6-4.4 (4.7-4.4)
121-114 (122-115)	121-115 (122-116)
A	A
Euro 5	Euro 5
50/6.0	50/6.0
486-1545	486-1545
11.0	11.0
1475 (1505)	1475 (1505)
2030 (2025)	2030 (2025)

Figures in brackets refer to engines in conjunction with optional 7-speed dual clutch transmission 7G-DCT, in all likelihood available from 1<sup>st</sup> quarter of 2012

<sup>1</sup> Figures according to Directive 80/1269/EEC in the currently applicable version <sup>2</sup> The figures shown were obtained in accordance with the prescribed measuring process (Directive 80/1268/EEC in the currently applicable version)  
<sup>3</sup> The figures are not based on an individual vehicle and do not constitute part of the product offer; they are provided solely for the purposes of comparison between different vehicle models

No. of cylinders/arrangement
Total displacement (cc)
Rated output <sup>1</sup> (kW at rpm)
Rated torque <sup>1</sup> (Nm at rpm)
Acceleration from 0–100 km/h (s) (7G-DCT)
Top speed, approx. (km/h)
Tyre size front axle
Tyre size rear axle
Fuel
Fuel consumption <sup>2</sup> (l/100 km)
Urban (7G-DCT)
Extra-urban (7G-DCT)
Combined (7G-DCT)
CO <sub>2</sub> emissions <sup>2</sup> (g/km) combined (7G-DCT)
Efficiency class
Emission class
Tank capacity (l)/incl. approx. reserve
Boot capacity (l)
Turning circle diameter (m)
Kerb weight <sup>3</sup> (kg) (7G-DCT)
Perm. GVW (kg) (7G-DCT)

#### PETROL ENGINES

B 180 BlueEFFICIENCY	B 200 BlueEFFICIENCY
4/in-line	4/in-line
1595	1595
90/5000	115/5300
200/1250–4000	250/1250–4000
10.4 (10.2)	8.6 (8.4)
190	220
195/65 R 15	205/55 R 16
195/65 R 15	205/55 R 16
Premium petrol	Premium petrol
8.3–8.0 (8.3–7.9)	8.3–8.0 (8.3–7.9)
5.0–4.7 (5.0–4.7)	5.0–4.7 (5.0–4.7)
6.2–5.9 (6.2–5.9)	6.2–5.9 (6.2–5.9)
144–137 (145–137)	144–138 (145–138)
C	C
Euro 5	Euro 5
50/6.0	50/6.0
486–1545	486–1545
11.0	11.0
1395 (1425)	1395 (1425)
1960 (1950)	1960 (1950)

<sup>3</sup> Figures according to Directive 92/21/EC, version 95/48/EC (kerb weight with fuel tank 90% full, driver, 68 kg, and luggage, 7 kg) for standard-specification vehicles. Optional extras and accessories will generally increase this figure and reduce the payload capacity accordingly

NON-METALLIC PAINTS



METALLIC PAINTS

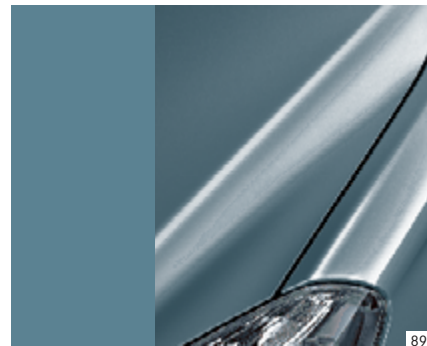
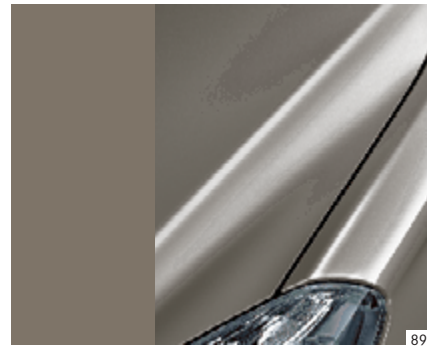
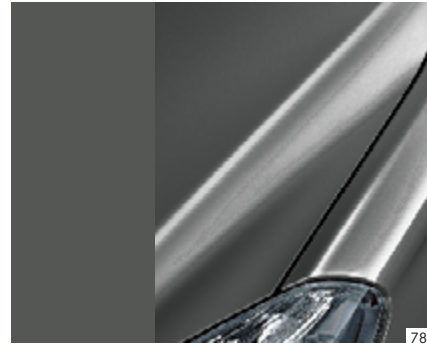
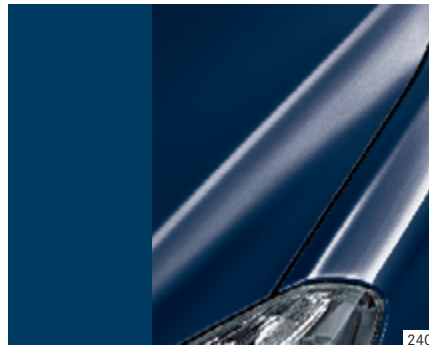

**Take-back of end-of-life vehicles.** Coming full circle. At the end of its long life, you can return your B-Class to us for environment-friendly disposal in accordance with the EU End-Of-Life Vehicle Directive<sup>1</sup>. But that day lies a long way off.

<sup>1</sup> Applies in accordance with national regulations to vehicles up to 3.5 tonnes gross weight. Mercedes-Benz passenger cars have met the statutory regulations governing the suitability of their design for reuse and recycling for a number of years now. A network of vehicle take-back depots and dismantlers has been established which will process your vehicle in an environment-friendly manner. The ways in which both vehicles and parts can be recovered are subject to ongoing development and improvement. Consequently, the B-Class will be able to comply with any future increases in the recycling quota within the stipulated time limits.

**Please note:** changes may have been made to the product since this brochure went to press (10.05.2011). The manufacturer reserves the right to make changes to the design, form, colour and specification during the delivery period, provided these changes, while taking into account the interests of the vendor, can be deemed reasonable with respect to the purchaser. Where the vendor or the manufacturer uses symbols or numbers to describe an order or the subject of an order, no rights may be derived solely from these. The illustrations may show accessories and items of optional equipment which are not part of standard specification. Colours may differ slightly from those shown in the brochure, owing to the limitations of the printing process. This brochure is distributed internationally. It provides a general indication of the range of models, features, optional extras and/or colours available in various countries. Some of the models, features, optional extras and/or colours shown may not be available in your country or may only be available in a different specification. Additionally some models, features, optional extras and/or colours may only be available in combination with others. For current and more specific information in relation to the range of models, features, optional extras and/or colours available in your country, and their pricing, you should contact your nearest authorised Mercedes-Benz Passenger Car Dealer. [www.mercedes-benz.com](http://www.mercedes-benz.com)