

The all-new 2012 SLK-Class



Mercedes-Benz
The best or nothing.



SLK 350.



Mercedes-Benz and the classic roadster have been irrevocably linked for a century. So who better to refine this much-heralded class of motorcar? The SLK-Class keeps the spirit and passion of the roadster alive with a sense of refinement like no other. Power, precision, and presence combine to form a vehicle that is exhilarating to look at, but even more so to drive. So much more than a sporty convertible, the SLK keeps with Mercedes-Benz's reputation for setting the standard in automotive design. And with such an icon in your garage, you'll enjoy quite a reputation yourself.

The SLK-Class

DESIGN	2
ENTERTAINMENT & COMMUNICATION	8
AGILITY	10
SAFETY	14
COLOURS & MATERIALS	16
EQUIPMENT LISTING	22
ACCESSORIES & TECHNICAL DATA	24
OWNERSHIP, WEBSITE & TEST DRIVE	26

Where form follows function, and your heart.

One look and its power is loud and clear: long bonnet and short overhangs, the visual dynamics of the SLK will take your eyes all the way back. And one drive is enough to see that this roadster delivers what its design promises. The third generation of the SLK-Class continues to fascinate with its dynamic, masculine look. Its long, contoured hood descends toward the nose while the wide, low bumper with large air inlets extends out to the sides of the vehicle, creating a broader, more dynamic appearance. Side air vents mounted in the fender pay homage to the classic 300 SL roadster of the 1950s, while integrated tailpipes fit nicely below a clean rear diffuser. Sitting atop 18" AMG 5-spoke wheels, the all-new 2012 SLK 350 will not only turn heads, but also make them jealous – and it doesn't stop there. The AMG Styling Package is fitted as standard equipment on the SLK 350 – unparalleled dynamism with a body design that meets the most discerning requirements and utmost attention to detail.





SLK 350.



SLK 350.



The world is yours when you control the sky.

Imagine controlling light and shadow. The SLK 350 with optional MAGIC SKY CONTROL¹ turns fantasy into reality. One touch lets sunlight in through a transparent glass roof, or darkens it within seconds to provide a cool, transparent shade. An industry first, MAGIC SKY CONTROL uses electric impulses to rearrange tiny crystals on a wafer-thin film sitting between two layers of the panoramic roof, effectively blocking out the desired amount of incoming sunlight. Depending on the intensity of sun, virtually 100% of the light can be let in – or up to 75% can be blocked out – all at the touch of a button. Even when the roof is in its transparent state, the driver remains comfortable and protected from the summer heat. Unfortunately, the only thing the panoramic vario-roof with MAGIC SKY CONTROL can't do is make the sun shine on a cloudy day.

Though whatever the weather condition, the SLK has got you covered. The all-new innovative AIRGUIDE² option shields the driver and passenger from wind, redirecting air turbulence around the cockpit preventing a draft effect. Meanwhile, the AIRSCARF² option provides warm airflow to the upper body and head, keeping the occupants nice and warm on those colder days and extending the open-top driving season well into late autumn.

¹Available in conjunction with the Premium Package.

²Available as part of an option package.

Have a seat. You're about to be overwhelmed.

Step inside the new SLK and you'll know you've arrived. More luxurious and refined in style, the new SLK definitely stays close to its roots. Open the door and gentle red ambient lighting greets you – a true sight to behold. Rich details – like the available Nappa leather upholstery – and beautiful trim selections with newly available Brushed Aluminum and Dark Ash finishes create a stylish and comfortable cabin that feels like it has been designed around you.



SLK 350 Ambient lighting.





SLK 350 Interior.

Let the performance begin.

A world of acoustic options is at your fingertips in the SLK 350. The optional 500-watt harman/kardon® LOGIC7®¹ surround sound system gives you unparalleled sound quality from every seat with 10 precisely placed speakers. SIRIUS Satellite Radio^{1,2}, features 120 channels, including 100% commercial-free music from every genre, plus sports, news, talk and comedy – all with crystal-clear, coast-to-coast coverage.

The centre console of the SLK-Class features the latest-generation COMAND APS³ multimedia control and display system that combines audio, Bluetooth and a hard-drive based GPS navigation system – all of which can be controlled through the LINGUATRONIC voice operated control system. Plus, an intelligently designed interface supports more media devices than ever before, yet remains as user-friendly as always. Being entertained on your travels will never be a worry in the SLK 350 – though deciding what to do first might be.



The harman/kardon® LOGIC 7® surround sound system ensures a listening experience of the highest caliber.



COMAND APS multimedia control and display system.



¹Available as part of an option package. ²© 2011 SIRIUS Satellite Radio Inc. "SIRIUS," the SIRIUS dog logo and related marks are trademarks of SIRIUS Satellite Radio Inc. Complimentary 6 months of service included. Monthly subscription required for service thereafter. ³Available as a standalone option.



SLK 350 Interior.

The heart beats faster.

Fun at the wheel and environmental responsibility can live together in harmony. Newly developed engine technologies impress with power while reducing fuel consumption at the same time.

Increased adrenaline. Reduced emissions.

Performance meets fuel economy. Luxury meets responsibility. At Mercedes-Benz, we don't believe in compromise. Our BlueEFFICIENCY philosophy ensures that environmental responsibility plays a major role in all we do. We do this at all levels of vehicle development and production – and therefore take a comprehensive approach to all the potential factors relating to drive systems, lightweight construction, energy management and fuels. This all-round approach also includes aspects such as the total harmful emissions, choice of materials, development, production, use and servicing, right up to eventual vehicle recycling and disposal. The world's awareness is increasing as emissions, fuel consumption and fuel prices become topics that affect us all. For Mercedes-Benz it is both a corporate goal and an obligation to shape the future of mobility in a responsible and sustainable manner.

A power plant on 4 wheels.

Powered by a new 3.5L direct injection V6 engine, the all-new SLK 350 offers plenty of performance. A marvel of Mercedes-Benz engineering, its 302 horsepower and 273 lb-ft of torque will raise the speedometer from 0-100km/h in just 5.6 seconds. When driving the SLK, the only thing faster would be the beating of your heart.

Well geared for the road.

The SLK 350 is equipped with the 7G-TRONIC PLUS 7-speed automatic transmission as standard equipment. This wide range of closely spaced gears gives the driver the ideal gear for virtually any driving situation, and makes for smoother cruising, more responsive acceleration and even improved fuel efficiency.

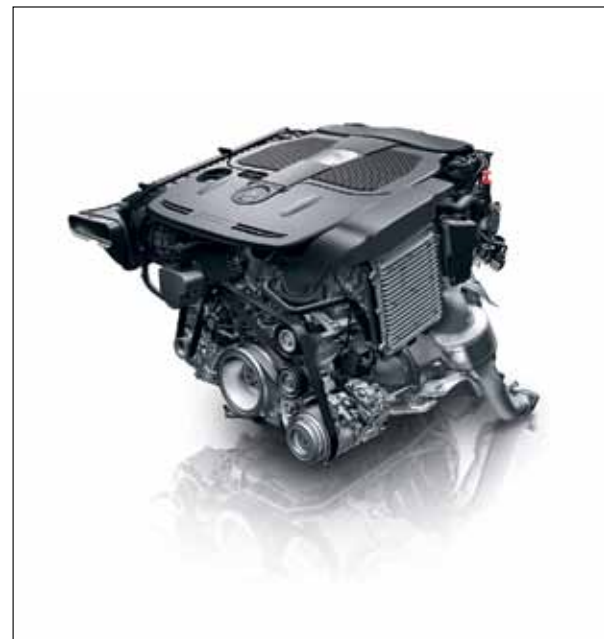

The SLK's engine combines comfort and fun at the wheel with sustainability.

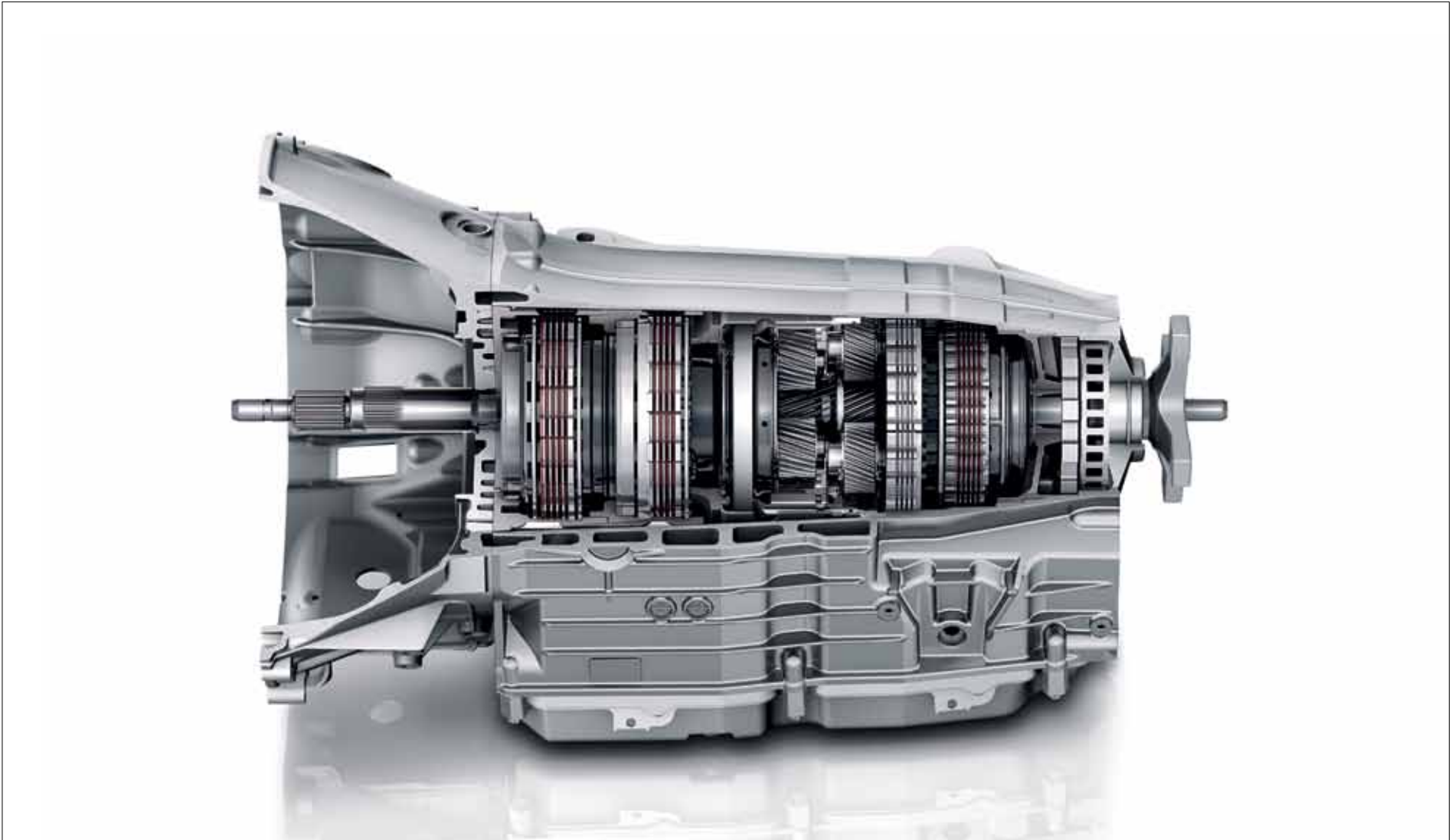

The 7G-TRONIC PLUS: one of over 18 million automatic transmissions produced in a period spanning more than 50 years.

Precision driver meets precision machine.

The precision of the SLK is further sharpened by a number of sophisticated technologies with the standard Dynamic Handling Package. A button marked 'Sport' launches several systems into action. The Adaptive Damping Suspension stiffens the chassis and affords the SLK even more handling agility. The Direct-Steer system increases the weight of the steering and reduces the number of turns from lock to lock – ensuring razor-sharp handling on tight bends and improved straight-line stability at high speeds. Finally, the Torque Vectoring Brake system significantly reduces understeer, ensuring precise cornering and outstanding driving dynamics. All told, the SLK's Dynamic Handling Package brings you closer to the road than ever.



The Dynamic Handling Package with adaptive adjustable damping: facilitates the ideal blend of sportiness and comfort.



Safety always comes standard.

Mercedes-Benz always pursues a vision of accident-free driving. Numerous measures can support the driver in critical situations, helping to prevent dangerous situations.

ADAPTIVE BRAKE

With the anti-lock braking system (ABS) and the Electronic Stability Program (ESP®) the ADAPTIVE BRAKE system helps drivers master critical braking maneuvers.¹ By wiping moisture away while driving in wet conditions, this technology allows the brakes to react with more accuracy. Also, ADAPTIVE BRAKE prevents unintentional roll back when starting on an incline. Pressing the brake a second time activates the HOLD function, keeping the vehicle securely in place.

DISTRONIC PLUS with PRE-SAFE® Brake^{1,2,3}

DISTRONIC PLUS is a radar-based proximity cruise control system which accelerates and decelerates the SLK autonomously to maintain a pre-set distance from vehicles ahead - ideal for stop-and-go traffic. Should the vehicle ahead slow to a standstill, DISTRONIC PLUS will bring the vehicle to a complete stop. With a simple tap of the accelerator pedal,

DISTRONIC PLUS will once more resume the driver's pre-set speed. Leveraging DISTRONIC PLUS, PRE-SAFE® Brake is a sophisticated active safety system capable of preventing rear-end collisions. This anticipatory system uses the DISTRONIC PLUS radar technology to continuously monitor the space in front of the vehicle. If it determines that a collision is possible, and the driver is not taking steps to slow the vehicle and avoid the accident, PRE-SAFE® Brake will firstly warn the driver visibly and audibly. If the driver has still not reacted, PRE-SAFE® Brake will trigger partial braking to slow the vehicle down. Finally, if PRE-SAFE® Brake determines that a collision is imminent, it will then engage full braking to mitigate damage - acting as a virtual crumple zone. If the driver does react to these warnings, however, the SLK's advanced BRAKE ASSIST PLUS system will boost brake pressure to ensure maximum braking power is available to stop the vehicle and avoid an accident.

Standard Airbags

Since 1992, airbags have been a standard safety feature on all Mercedes-Benz passenger cars. The SLK continues this tradition with an impressive total of eight standard-fit airbags – two front airbags which are deployed in two stages depending on the severity of the accident, two side airbags in the seat backrests, two head airbags positioned in the door panels and two knee airbags, providing substantial protection should a collision occur⁴. Working in conjunction with the seatbelts, the airbags can significantly reduce the risk of injury to the driver and passenger in the event of a collision.

¹No system, regardless of how advanced, can overcome the laws of physics or correct careless driving. Please always wear your seat belt. Best performance in snow is obtained with winter tires. ²Available as part of an option package. ³Delayed availability. ⁴WARNING: The forces of a deploying airbag can cause serious or fatal injuries to a child under age 13. See Operator's Manual for additional warnings and information on airbags, seatbelts and child seats.



Standard Active Bi-Xenon headlamps provide drivers with optimum visibility in all driving conditions.

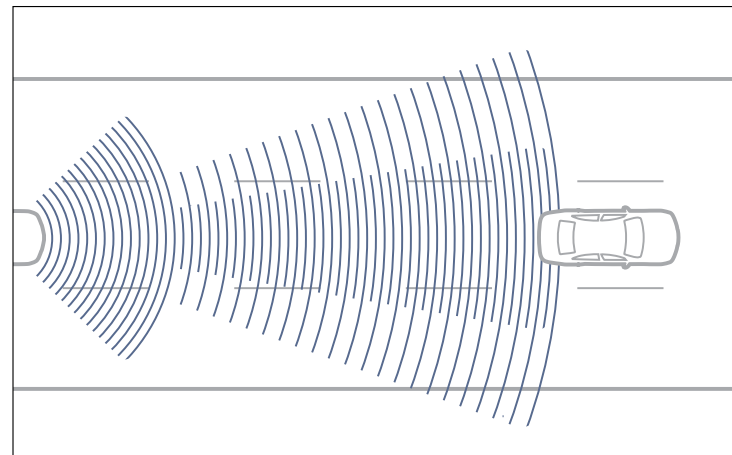

DISTRONIC PLUS^{1,2,3} with proximity control supports drivers by automatically keeping their vehicle at a safe distance from the vehicle in front.



Head airbags reduce the risk of injury by providing additional support in the event of a collision^{1,4}.

An expression of character.

The finishing touches can mean the difference between a work of art and a true masterpiece. Whichever colour you opt for, you've made the right choice. Because with a selection of both solid and metallic paint finishes benefiting from an extra scratch-resistant clear coat, your SLK's colour is less susceptible not only to scratches, but also to sunlight, temperature variations, dust and soot.



LEATHER
Black/Black
Sahara Beige/Black
Crystal Grey/Black
NAPPA LEATHER
Black/Black
Bengal Red/Black
Mocha Brown/Black

SOLID

Black	●	●	●	●	●	●
Fire Opal	●	○	●	●	○	○

METALLIC PAINT

Obsidian Black	●	●	●	●	●	●
Cavansite Blue	●	●	●	●	○	○
Iridium Silver	●	○	○	●	●	○
Tenorite Grey	●	●	●	●	●	●
Palladium Silver	●	○	●	●	●	○
Indium Grey	●	●	○	●	○	●
Pearl Beige	○	●	○	○	○	●
Diamond White	●	●	○	●	●	●
Galenite Silver	●	○	●	●	○	○

○ Possible Combination ● Recommended combination

SOLID

METALLIC (OPTIONAL)

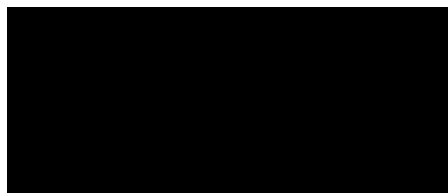

040 Black



197 Obsidian Black



755 Tenorite Grey



794 Pearl Beige



590 Fire Opal



890 Cavansite Blue



792 Palladium Silver

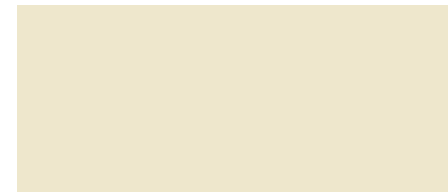

799 Diamond White



775 Iridium Silver



963 Indium Grey



967 Galenite Silver



Fine sport detailing provides the SLK 350 with a distinct character; blending luxury with exceptional sport design.

LEATHER



201 Black/Black



205 Sahara Beige/Black



208 Crystal Grey/Black

NAPPA LEATHER

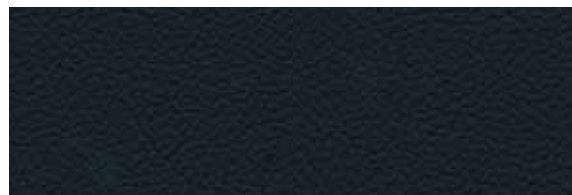

801 Black/Black



807 Bengal Red/Black

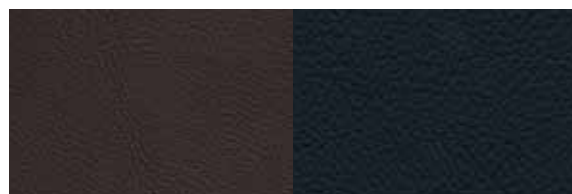

854 Mocha Brown/Black

TRIM



H76 Aluminum



731 Burl Walnut



736 Dark Ash

Individuality at its most alluring.

Transform your new SLK into a bespoke masterpiece with exceptional finishing touches by *designo*. The *designo* program offers you a myriad of personalization options to make your new vehicle truly unique, creating a character as distinguished as your own.

The *designo* range also includes a selection of additional features that complement your Mercedes-Benz. A variety of model-specific options are available, including Alcantara and full leather headliners and wood/leather steering wheels – the possibilities are endless. Speak to your dealer, or browse the whole range at your convenience using our online configurator at: mercedes-benz.ca/designo



SLK 350 Interior in *designo* Titan Pearl/Black Nappa leather.



SLK 350 Edition 1 with *designo* Glacier Grey MAGNO Paint.



A unique *designo* finish provides a distinguished look and offers exceptional character.

INDIVIDUAL EQUIPMENT

TRANSMISSION

 7G-TRONIC PLUS 7-speed automatic transmission

TRACTION/STABILITY

 AGILITY CONTROL suspension

 Direct Steering

 Electronic Stability Program (ESP®) including ABS and traction control (ASR)

 Brake Assist (BAS)

 Dynamic Handling Package

AUDIO/VISUAL/COMMUNICATION

 Bluetooth connectivity

 Media interface (with iPod®, USB and auxiliary connections) in centre console

 harman/kardon® LOGIC7® surround sound system

 SIRIUS Satellite Radio¹

 COMAND APS with HDD navigation & DVD changer, Music Register and SD memory slot, LINGUATRONIC voice control

SLK 350

▲

▲

▲

▲

▲

▲

▲

▲

○

○

△

INDIVIDUAL EQUIPMENT

EXTERIOR

 AMG 18" 5-spoke alloy wheels

 Heated windshield washer system with rain-sensing windshield wipers

 Active Bi-Xenon headlamp, LED daytime running lights and LED taillamps

 AMG Styling Package (front apron, side skirts, and rear apron)

 Exterior power folding mirrors

INTERIOR

 Heated seats

 10-way power-adjustable seats with 3-position memory

 Leather-wrapped multifunction sport steering wheel and shift knob

 Steering wheel shift paddles

 Aluminum sport pedals

 Leather upholstery

 Nappa leather upholstery

 Aluminum trim

SLK 350

▲

▲

▲

▲

▲

▲

▲

▲

▲

▲

▲

△

▲

INDIVIDUAL EQUIPMENT

Dark ash wood trim

Burl walnut wood trim

Ambient lighting

THERMOTRONIC dual-zone automatic climate control

Power windows with one-touch express up and down

Auto dimming mirrors (rearview and driver's side)

MAGIC SKY CONTROL

AIRGUIDE

AIRSCARF

Power-Tilt/telescoping steering column with 3-position memory

CONVENIENCE

SmartKey remote with panic button

Valet trunk locking

KEYLESS-GO

SLK 350

Δ

Δ

▲

▲

▲

▲

Δ²

○

○

▲

▲

▲

Δ

INDIVIDUAL EQUIPMENT

SAFETY

ATTENTION ASSIST

Seat belt height-adjustment

Dual stage-front airbags and headbag in doors, side airbags and knee airbags

TeleAid emergency calling system³

EQUIPMENT PACKAGES

PREMIUM PACKAGE:

PARKTRONIC with parking guidance, Analogue clock, AIRGUIDE with aluminum roll-bar inlay, AIRSCARF, Panoramic vario roof, SIRIUS Satellite Radio¹, harman/kardon[®] LOGIC7[®] surround sound system.

WOOD STEERING WHEEL & SHIFT KNOB PACKAGE:

Burl walnut wood/leather steering wheel and shift knob

DISTRONIC PLUS PACKAGE⁴:DISTRONIC PLUS, PRE-SAFE[®].

▲ Standard equipment Δ Optional Equipment ○ Optional as part of an option package

SLK 350

▲

▲

▲

Δ

Δ

Δ

Δ

¹© 2011 SIRIUS Satellite Radio Inc. "SIRIUS," the SIRIUS dog logo and related marks are trademarks of SIRIUS Satellite Radio Inc. Complimentary 6 months of service included. Monthly subscription required for service thereafter. ²Available in conjunction with the Premium Package. ³Subscription is required for service to be active. TeleAid operates only where cellular and Global Positioning System coverage is available. ⁴Delayed Availability.

The finishing touches.

Added nuances and unique refinement is just what will make your SLK-Class a distinctively richer automobile. Mercedes-Benz accessories are a cut above, having been designed and built to the highest standards for concept, engineering, quality, form and function.

Shallow Trunk Tray

- Made from impact-resistant, non-split polyethylene, this odourless tray prevents loads from sliding around and protects the carpet from spills and dirt.



Shallow Trunk Tray.

18" Twin-spoke Alloy Wheels

- Distinct 5-twin-spoke palladium silver wheels with an easy to clean, high-shine paint finish add an extra edge to your vehicle.



18" Twin-spoke Alloy Wheels.

Chrome Hood Grille Inserts

- Simple and quick to install, these visual upgrades add sportiness while completing the chrome accent of the SLK.



Chrome Hood Grille Inserts.

Rear Trunk Spoiler

- Tailored to the contours of the SLK, the athletic spoiler design reduces lift, thereby significantly reinforcing the vehicle's aerodynamics.



Rear Trunk Spoiler.

Technical data:

Engine type	SLK 350
Total displacement	24V DOHC V6
Net power	3,498 cm ³
Net torque	302 hp @ 6,500 rpm
Acceleration ¹ , 0–100 km/h	273 lb-ft @ 3,500-5,520 rpm
Approximate top speed ²	5.6 seconds
Tires, front rear	210 km/h
Fuel economy ³ , city/highway estimate	225/40 R 18 245/35 R 18
Fuel tank capacity	10.3 - 6.9 L/100 km
Fuel requirement	60.0 litres (with 8.0-litre reserve)
Dimensions ⁴	Premium unleaded
Wheelbase	2,430 mm
Overall length	4,134 mm
Overall height	1,303 mm
Overall width	2,006 mm
Curb weight	1,540 kg
Luggage capacity	225-335 litres

¹Stated rate of acceleration is based on the manufacturer's track results and may vary depending upon model, environmental and road surface conditions, driving style, elevation and vehicle load. ²Electronically limited. ³These estimates are based on Transport Canada testing methods. Estimates for the SLK 350 are based on 7G-TRONIC PLUS models. The actual fuel consumption of this vehicle may vary. Refer to the Fuel Consumption Guide. ⁴Dimensions shown are for model with standard equipment.

A passion for things done right.

A passion for craftsmanship and attention to detail – it's what you'd expect from Mercedes-Benz, setting us apart from all other manufacturers. It drives us to set new standards in design, performance, comfort and safety. To continually build on the legendary traditions of Mercedes-Benz, and to provide you with an ownership experience that includes the valuable benefits described below.

24-hour Roadside Assistance

During the basic warranty coverage of 48 months and the time duration of the optional Extended Limited Warranty, Mercedes-Benz Roadside Assistance will be at your service. We'll bring you some gas, replace a flat tire with your spare, or jumpstart your car. In the event of a mechanical breakdown, if attempts by our Roadside Assistance technician have not made your vehicle safely operable, towing service will be provided to the nearest Mercedes-Benz dealership. Assistance is available 24 hours a day, every day, to anyone driving a Mercedes-Benz anywhere in Canada or the continental U.S.¹

Wear and tear period

The following parts listed are covered for wear and tear during the first 24 months or 40,000 km, whichever comes first. Brake pads, brake discs, brake pad wear sensors and light bulbs.

Mercedes-Benz warranties

The Mercedes-Benz New Vehicle Limited Warranty covers defects in materials or workmanship for 48 months or 80,000 km, whichever comes first. To widen your window of confidence, you can opt for a Mercedes-Benz Extended Limited Warranty as well.²

Customer service

Owning a Mercedes-Benz means that when you have a question, we're here to help. Customer Service is open from 9 a.m. to 5 p.m. EST, Monday through Friday, and is staffed with knowledgeable Mercedes-Benz people who can talk you through the finer points of working your car's audio system – or even assist you in locating the nearest Mercedes-Benz dealership. Just call 1-800-387-0100. It's that simple.

Trip interruption reimbursement

If a breakdown covered by your New Vehicle Limited Warranty or optional Extended Limited Warranty occurs more than 80 km from your home, leaves your Mercedes-Benz vehicle inoperable or unsafe to drive, and requires overnight repairs, we've got you covered. You will be reimbursed up to \$500 for hotel accommodations and up to \$600 for alternative travel expenses per incident while your car is being repaired at an authorized Mercedes-Benz dealership.

¹Vehicle must be accessible from main roads. Roadside Assistance may involve charges for parts, service and towing. Depending on the circumstances, these services may be provided by an outside service provider, courtesy of Mercedes-Benz Roadside Assistance. For full details of the Roadside Assistance Program, please see your dealer. ²Please see your dealer for warranty details as well as for terms, conditions and pricing for extended warranty options.

Mercedes-Benz is virtually yours.

Visit mercedes-benz.ca and open an online window to Mercedes-Benz Canada. Revel in the incredible photography of our vehicles and get a visceral impression of what it would be like to see yourself behind the wheel. Access information about any of our vehicles, including financing and leasing options, upcoming models, and configure your dream Mercedes online. Our website also offers details about the Mercedes-Benz Extended Limited Warranty, vehicle ownership, and much more on the fascinating story behind one of the world's most recognizable brands.

To be continued. With Test drive.

Nowhere is your SLK so convincing as on the road. It's only there that you can fully experience the superior handling and power that makes this car so special. Feel the engine move you forward, and watch your heart rate rise with the speedometer. That unique feeling in your stomach cannot be put down on paper. That's why we would like to invite you in for a test drive at your local Mercedes-Benz dealer. Reserve your appointment today, or visit mercedes-benz.ca.



© 2011 Mercedes-Benz Canada Inc.

All illustrations and specifications contained in this brochure are based on the latest product information available at the time of publication. Mercedes-Benz Canada reserves the right to make changes at any time, without notice, in colours, materials, equipment, specifications and models. Any inaccuracies in colours shown are due to reproduction variations of the printing process. Some vehicles may be shown with non-Canadian equipment. Some vehicles may be shown without side marker lights. Some vehicles are shown with optional equipment available at extra cost. Some optional equipment may not be available on all models. For current information regarding the range of models, standard features, optional equipment and/or colours available in Canada and their pricing, contact your nearest authorized Mercedes-Benz dealer or visit mercedes-benz.ca. harman/kardon® and LOGIC7® are registered trademarks of Harman International Industries Inc. iPod® is a registered trademark of Apple Computer, Inc.

Printed in Canada
MBC-11-SLK12-3450E

Mercedes-Benz Canada Inc. 98 Vanderhoof Avenue, Toronto, Ontario M4G 4C9
1-800-387-0100
www.mercedes-benz.ca

