



The 2012 SL-Class



Mercedes-Benz
The best or nothing.

SL: two letters that spell “legend”.

The Mille Miglia is Italy’s most famous road race. Running through everything from sleepy little villages to the most impressive piazzas, it covers a full 1,600 kilometres and takes three days to complete. This is where the SL-Class’ most distinguished ancestor made history back in 1955.

The 2012 SL-Class roadster builds on these legendary racing roots with impressive engines and chassis that are truly worthy of the SL name. Combined with Mercedes-Benz craftsmanship, the SL-Class simply is a roadster unlike any other.

The SL-Class

DESIGN	2
ENTERTAINMENT & COMMUNICATION	8
GRAND EDITION & AVANTGARDE EDITION	10
AGILITY	12
SAFETY	16
AMG	18
COLOURS & MATERIAL	20
EQUIPMENT LISTING	24
TECHNICAL DATA & ACCESSORIES	26
OWNERSHIP, WEBSITE & TEST DRIVE	28



SL 550 AVANTGARDE Edition.



SL 550 AVANTGARDE Edition.



SL 550 GRAND Edition.

The sporting meets the sublime.

A low seating position and a sense of the sublime are waiting for you aboard the 2012 SL-Class.

Your eyes dance along the roadster's elongated nose, whose power domes hint at the powerful engine that lies within. Gently press the accelerator and its smooth power delivers you to your destination in a breeze.

But it goes way beyond performance. Design elements, like the impressive side vents add visual excitement as well. Exclusive paint finishes, attractive wheels and performance tires add to this effect, as does the AMG Styling Package, which is standard on all models. Its sharply contoured front and rear aprons and side sills add final touches that are to die for.

When it comes to a total driving experience, the SL-Class is the complete package.

Magnify the sky.

Make that sunset last a little longer. The innovative retractable hardtop roof gives you the security of a coupe and the freedom of an open-air roadster. At the touch of a button, the SL-Class' top disappears in 16 seconds – one of the fastest retractable hardtops in production. Even with the hardtop retracted into the rear, the SL-Class has enough trunk space to carry two golf bags.

If that's not enough, experience the open sky in any weather with the panoramic vario-roof. A tinted glass section replaces the conventional metal roof deck above the driver and passenger, allowing you to magnify the sky. On hot days, shade yourself from the sun with an extendable screen.

Meet the innovative AIRSCARF system. At the touch of a button, fans at the rear of the head restraints draw in air that is then heated and passed through the front of the seat. The warm air wraps itself round your head and neck, prolonging the open-top driving season. Three settings let you select the perfect temperature.



The AIRSCARF system.





SL 550 AVANTGARDE Edition.

Some comforting thoughts.

Surround yourself in opulent Burl Walnut¹, Dark Ash², Prism Pattern Aluminum Trim³ or opt for the sleek AMG Carbon Fibre⁴ on the SL 63 AMG AVANTGARDE Edition. Splendor in luxurious leather upholsteries, available in a variety of rich colour combinations. The leather trim for the instrument cluster is a highly complementary detail, and the celebrated 3-spoke steering wheel trimmed in supple leather and high-gloss Burl Walnut, Light Burl Walnut or Dark Ash wood is a magnificent addition.

Multicontour leather allows you to adjust your seat to the unique contours of your body. Air cushions in the lumbar and side bolsters provide lateral support when cornering. With the push of a button, air pads gently pulsate to massage your back muscles. The Climate Comfort seats feature heat at the touch of a button, as well as active ventilation to keep you cool on warm top-down summer days.

Enjoy perfect climatic comfort with THERMOTRONIC automatic climate control, standard in all SL-Class models. Automatic adjustments are made for individual occupants based on sunlight intensity and moisture. Plus, a sophisticated air filter for dust and pollutants keeps the air ultra-clean.

When it comes to comfort, the SL-Class leaves nothing to be desired.

¹Standard on the SL 550 AVANTGARDE Edition and includes matching wood and leather steering wheel. Available as a standalone option on the SL 63 AMG AVANTGARDE Edition. Not available in conjunction with the GRAND Edition Package. ²Available as a standalone option on the SL 550 AVANTGARDE Edition & the SL 63 AMG AVANTGARDE Edition. Not available in conjunction with the Grand Edition Package. ³Only available in conjunction with the GRAND Edition Package. Not available on the SL 63 AMG AVANTGARDE Edition. ⁴Standard on the SL 63 AMG AVANTGARDE Edition. Not available on the SL 550 AVANTGARDE Edition or in conjunction with the Grand Edition Package.





SL 550 AVANTGARDE Edition interior.

High technology equals high simplicity.

The cockpit of the SL-Class is designed with ergonomics in mind, and features perfectly positioned controls and displays.

Experience radio like never before with SIRIUS Satellite Radio¹, featuring 120 channels, including 100% commercial-free music from every genre, plus sports, news, talk and comedy – all with crystal-clear, coast-to-coast coverage. Also standard is the harman/kardon[®] LOGIC7[®] surround sound system, with high performance speakers and Digital Signal Processors (DSP) for optimal acoustics within the interior of a roaster. It even adjusts itself when the top goes down.

The SL's Media Interface offers full integration with the harman/kardon[®] LOGIC 7[®] surround sound system. It features three connection options via USB,

iPod[®] or auxiliary audio input, and allows you to control your iPod[®] playlists with the multifunction steering wheel buttons of the COMAND APS system.

The COMAND APS control and display system combines navigation, Bluetooth connectivity, audio and telephone into one elegant 6.5" high-resolution full colour screen. For ease of operation, all key functions can be called up by means of the LINGUATRONIC voice control function that recognizes street and city names without the need for voice training or spelling. The SD memory card slot and MUSIC REGISTER function that provides up to 4GB of storage space on the internal hard drive further improve MP3 capabilities.

¹ © 2011 SIRIUS Satellite Radio Inc. "SIRIUS," the SIRIUS dog logo and related marks are trademarks of SIRIUS Satellite Radio Inc. Complimentary 6 months of service included. Monthly subscription required for service thereafter.



harman/kardon[®]LOGIC7[®]surround sound system.



COMAND APS with navigation.



SL 550 GRAND Edition.



Two ultimate models, one tough decision.

Two special models are offered that continue to deliver on the SL-Class' heritage of exceptional performance, all while delivering outstanding value.

Already handsomely equipped, the SL 550 AVANTGARDE Edition includes DISTRONIC proximity control, Climate Comfort seats, AIRSCARF, panoramic vario-roof, power trunk closer and KEYLESS-GO as standard equipment.

For even more exclusivity there's the SL 550 GRAND Edition. Available in the exclusive and desirable *designo* crystal silver, this Edition includes unique features in addition to the standard SL 550 AVANTGARDE Edition, including clear headlights and taillights, aluminum framed wind blocker, matte-silver fins, leather wrapped sport steering wheel, Edition exclusive prism aluminum trim, Nappa leather and GRAND Edition floor mats. It truly is a sight to behold, and an experience that only a fortunate few will be able to own.

Which flavour of outstanding performance would you prefer?

Mercedes-Benz has been making racing history with the SL-Class since the legendary Gullwing model of 1954. But it has never been quite as dynamic as it is today, equipped with eight cylinder engines that deliver spine-tingling acceleration.

The SL-Class experience starts with a V8 engine under the hood of the SL 550 AVANTGARDE Edition and SL 550 GRAND Edition. Producing 382 hp and 391 lb-ft of torque, it effortlessly catapults the driver to 100 km/h in a mere 5.4 seconds.

For those who crave even more power, the SL 63 AMG AVANTGARDE Edition features an astounding 518 hp V8 engine that soars to 100 km/h in a remarkable 4.6 seconds.

Whichever model you choose, performance will never be an issue. With the 2012 SL-Class, it's merely a matter of degrees.



SL 550 AVANTGARDE Edition.



SL 550 AVANTGARDE Edition.



Behold the SL 63 AMG's 518 hp heart, hand-built with passion.

There's nothing you can't handle.

Underneath the beautifully sculpted body of the SL-Class, you'll find engineering that reinforces its legendary status.

The 7G-TRONIC 7-speed automatic transmission, standard on the SL 550 AVANTGARDE Edition, makes shifting virtually imperceptible and delivers improved power and acceleration. The SL 550 AVANTGARDE Edition also comes standard with the Sport Package, which includes two shift paddles mounted to a sport steering wheel for manual gear changes, upgraded front calipers, and perforated brake rotors for even more control over the road.

Taking performance a step further, the SL 63 AMG AVANTGARDE Edition features the innovative AMG SPEEDSHIFT MCT 7-Speed sports transmission. Standing for "Multi-Clutch Technology", MCT offers shift times are 20% faster than our already lightening-fast AMG SPEEDSHIFT 7G-TRONIC unit, and the automatic double-declutching and race start functions ensure optimal performance.

The SL-Class' standard Active Body Control (ABC) system also helps to deliver the perfect ride. Ten sensors monitor the vehicle's handling. Continuous automatic adjustment of each wheel's suspension counteracts vibration, roll, pitching and braking. Lateral movements are also reduced when cornering. The suspension is automatically lowered at higher speeds.

For added convenience, the standard DISTRONIC proximity control takes cruise control to a whole new level. At speeds from 30-180 km/h, radar sensors automatically keep you at a safe and constant distance from the vehicle in front of you. Plus, the standard PARKTRONIC feature helps you park, with audible and visual warnings when objects are in close proximity.



19" AMG 5-spoke wheels¹



19" AMG bi-colour twin 5-spoke wheels²



19" AMG twin 5-spoke forged wheels³

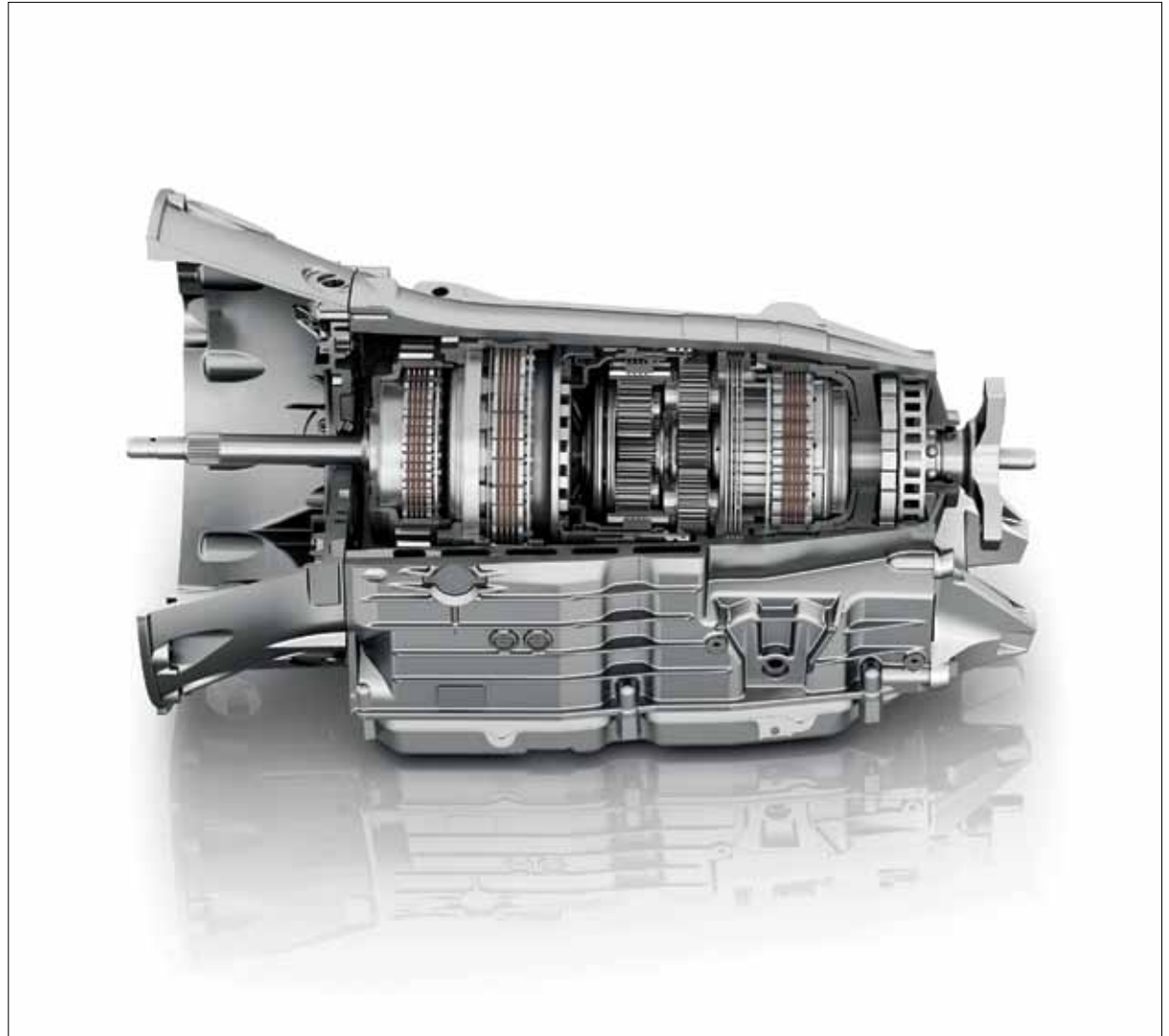

The 7G-TRONIC automatic transmission; one of over 18 million automatic transmissions produced in a period spanning more than 50 years.

Proven safety for the road ahead.

Whichever route you choose, you'll always be taking the safe road with the SL-Class thanks to the pioneering safety technology on board.

Mercedes-Benz has led the way in roadster safety since 1989 when it fitted the first ever sensor-controlled rollover bar as standard in the SL-Class. At the heart of this technology is a tilting-cone sensor that works with an electronic control unit to detect when the SL-Class is at a critical tilt angle. Normally concealed out of sight, the rollover bar can extend fully in just 0.3 seconds the instant danger is sensed.

In case of a collision, the SL-Class offers you the best possible protection. The driver and passenger air bags¹ trigger in a matter of milliseconds in the event of a collision, and the large-capacity head/thorax air bags on both sides inflate in response to a side impact. Post-accident functions include automatic engine shut-off and a signal sent to the TeleAid² Emergency Response Center, where trained specialists can assess the situation and alert emergency services, if required.

¹WARNING: The forces of a deploying airbag can cause serious or fatal injuries to a child under the age of 13. See Operator's Manual for additional warnings and information on airbags, seat belts and child seats. ²First year's monitoring provided at no cost with subscription, Subscription is required for service to be active. TeleAid operates only where cellular and Global Positioning System coverage is available. ³No system, regardless of how advanced, can overcome the laws of physics or correct careless driving. Please always wear your seat belt. Best performance in snow is obtained with winter tires.

The Electronic Stability Program (ESP[®]) can dramatically enhance cornering control by monitoring your steering and braking actions and responding nearly instantaneously if it detects a loss of directional control or stability.³ If your SL-Class begins to fishtail (oversteer) or plow (understeer), ESP[®] can apply the brakes to any of the four wheels or reduce excess power to help you regain control and stay on course.

Active Bi-Xenon headlights come standard on all models, providing much better illumination than conventional headlights. The cornering light function uses a wider fog lamp beam to illuminate the road in the direction you are turning. This effectively allows you to see around dark corners and respond to potential hazards accordingly.



Active Bi-Xenon headlamps.



The energy-absorbing crumple zones, an extremely robust safety passenger cell, and the doors with special reinforcing elements form an effective defensive barrier in an emergency.



AMG

Peerless and powerful.

AMG and SL – two sets of letters that are synonymous with motoring passion and exclusivity. When fused together, the result is a sensational sport car unlike any other.

The SL 63 AMG AVANTGARDE Edition features an aggressive and dominating exterior. Sharply defined edges and lines flow from the large front air dam and chrome-ringed fog lamps, right to the twin chromed tailpipes and a diffuser-ridged rear apron. The effect is captivating.

The SL 63 AMG AVANTGARDE Edition also features a 6.2-litre 32-valve V8 engine with 518 hp. This impressive power plant is managed perfectly by the revolutionary AMG SPEEDSHIFT MCT 7-speed sport transmission. Electronic speed limiter deletion¹, limited-slip differential, AMG Sport suspension, AMG Performance steering wheel and distinctive 19" AMG twin 5-spoke forged alloy wheels with performance tires complete the package.

Simply put, this roadster is without peers.



SL 63 AMG AVANTGARDE Edition.

¹Intended for track use only. Please obey all speed laws.

An expression of character.

The finishing touches can mean the difference between a work of art and a true masterpiece. Whichever colour you opt for, you've made the right choice. Because with a selection of both solid and metallic paint finishes benefiting from an extra scratch-resistant clear coat, your SL's colour is less susceptible not only to scratches, but also to sunlight, temperature variations, dust and soot.



LEATHER¹	Black/Black	Pebble Beige/Dark Pearl	Flamenco Red/Black	Alpaca Grey/Dark Alpaca Grey	Natural Beige/Black	NAPPA LEATHER²	Black/Black	Flamenco Red/Black	Natural Beige/Black	AMG PASSION LEATHER³	Black/Black	Pebble Beige/Dark Pearl	Flamenco Red/Black	Alpaca Grey/Dark Alpaca Grey
----------------------------	-------------	-------------------------	--------------------	------------------------------	---------------------	----------------------------------	-------------	--------------------	---------------------	--	-------------	-------------------------	--------------------	------------------------------

SOLID PAINT

Black	●	●	●	●	●	●	●	●	●	●	●	●	●	●
Fire Opal	●	●	●	○	○	-	-	-	●	●	●	○	○	○

METALLIC PAINT

Magnetite Black	●	●	●	●	●	●	●	●	●	●	●	●	●	●
Obsidian Black	●	●	●	●	●	●	●	●	●	●	●	●	●	●
Thulite Red	●	●	○	○	○	-	-	-	●	●	○	○	○	○
Tenorite Grey	●	●	●	○	○	-	-	-	●	●	●	○	○	○
Diamond White	●	○	●	●	●	●	●	●	●	○	●	●	●	●
Palladium Silver	●	○	●	●	○	●	●	○	●	○	●	●	●	●
<i>designo</i> Crystal Silver	-	-	-	-	-	●	●	○	-	-	-	-	-	-
Alabandite Green	●	○	●	●	○	-	-	-	●	○	●	●	●	●
Iridium Silver	●	○	●	○	●	-	-	-	●	○	●	●	○	○

● Recommended combination ○ Possible Combination - Not Available

¹Standard on the SL 550 AVANTGARDE Edition. Not available on the SL 63 AMG AVANTGARDE Edition or in conjunction with the Grand Edition Package. ²Standard on the SL 550 in conjunction with the GRAND Edition Package. Not available on the SL 550 AVANTGARDE Edition or the SL 63 AMG AVANTGARDE Edition. ³Standard on the SL 63 AMG AVANTGARDE Edition. Not available on the SL 550 AVANTGARDE Edition or in conjunction with the GRAND Edition Package.

SOLID PAINT

METALLIC PAINT (OPTIONAL)

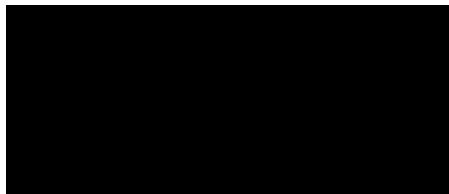

040 Black

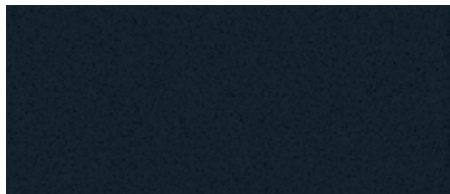

183 Magnetite Black



755 Tenorite Grey

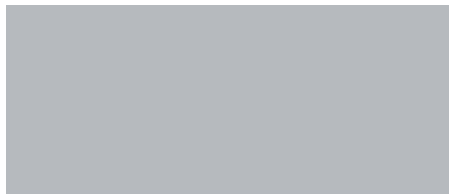

058 *designo* Crystal Silver



590 Fire Opal

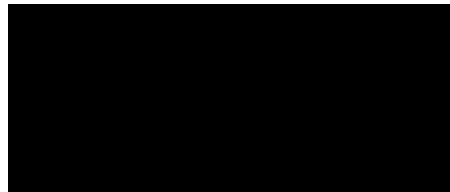

197 Obsidian Black

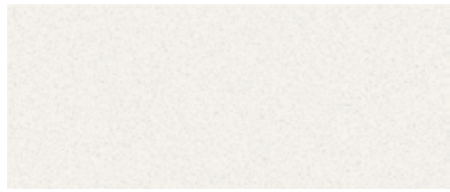

799 Diamond White



779 Alabandite Green



541 Thulite Red



792 Palladium Silver

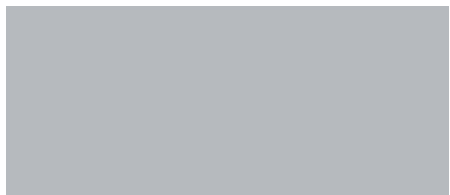

775 Iridium Silver

LEATHER¹



211 Black/Black



215 Pebble Beige/Dark Pearl

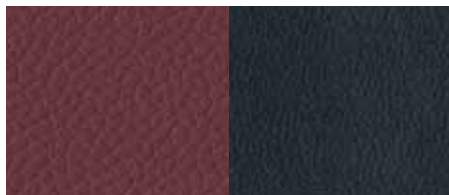

217 Flamenco Red/Black



218 Alpaca Grey/Dark Alpaca Grey



214 Natural Beige/Black

NAPPA LEATHER²



801 Black/Black



807 Flamenco Red/Black



804 Natural Beige/Black

AMG NAPPA LEATHER³

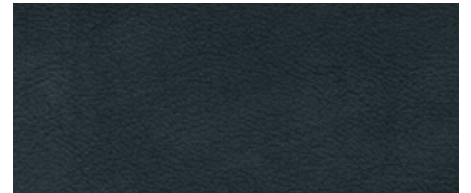

211 Black/Black



215 Pebble Beige/Dark Pearl

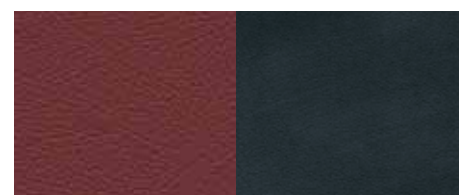

217 Flamenco Red/Black

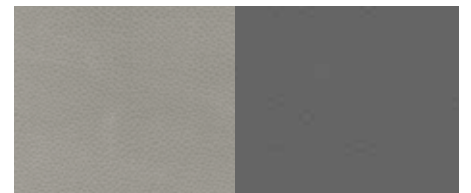

218 Alpaca Grey/Dark Alpaca Grey

TRIM

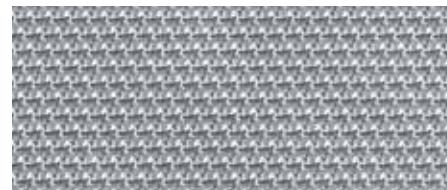
731 Burl Walnut Wood⁴H75 AMG Carbon Fibre⁶736 Dark Ash Wood⁵H73 Prism Pattern Aluminum⁷H12 Light Burl Walnut Wood⁵

ROOF LINER

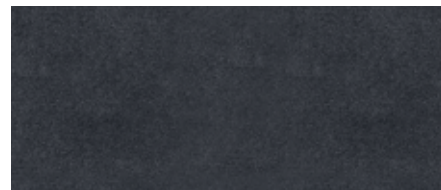
Y83 *designo* Anthracite Alcantara Roof LiningY85 *designo* Alpaca Grey Alcantara Roof LiningY84 *designo* Pebble Beige Alcantara Roof Lining

¹Standard on the SL 550 AVANTGARDE Edition. Not available on the SL 63 AMG AVANTGARDE Edition or in conjunction with the GRAND Edition Package. ²Standard on the SL 550 in conjunction with the GRAND Edition Package. Not available on the SL 550 AVANTGARDE Edition or the SL 63 AMG AVANTGARDE Edition. ³Standard on the SL 63 AMG AVANTGARDE Edition. Not available on the SL 550 AVANTGARDE Edition or in conjunction with the GRAND Edition Package. ⁴Standard on the SL 550 AVANTGARDE Edition and available as a standalone option on the SL 63 AMG AVANTGARDE Edition. Not available in conjunction with the GRAND Edition Package. ⁵Available as a standalone option on the SL 550 AVANTGARDE Edition and the SL 63 AMG AVANTGARDE Edition. Not available in conjunction with the GRAND Edition Package. ⁶Standard on the SL 63 AMG AVANTGARDE Edition. Not available on the SL 550 AVANTGARDE Edition or in conjunction with the GRAND Edition Package. ⁷Available on the SL 550 only in conjunction with the GRAND Edition Package. Not available on the SL 63 AMG AVANTGARDE Edition.

INDIVIDUAL EQUIPMENT

INTERIOR CONTINUED

Power-tilt/telescoping steering column with 3-position memory

Power windows with one-touch express up and down

Fabric windscreen

Rear luggage belts

CONVENIENCE

PARKTRONIC

DISTRONIC

SmartKey remote with panic button

KEYLESS-GO

Power trunk closure

Integrated garage door opener

Valet trunk locking

Locator lighting with headlamp switch-off delay

Power steering column with EASY ENTRY feature

SAFETY

TeleAid emergency calling system³

Anti-theft alarm system with tow-away protection

Dual-front airbags and head/thorax side airbags

Two 3-point height-adjustable seat belts

Belt tensioners with belt-force limiters

Tire pressure monitoring system

SL 550
AVANTGARDE EDITIONSL 63 AMG
AVANTGARDE EDITION

▲ ▲

▲ ▲

▲ ▲

▲ ▲

▲ ▲

▲ ▲

▲ ▲

▲ ▲

▲ ▲

▲ ▲

▲ ▲

▲ ▲

▲ ▲

▲ ▲

▲ ▲

▲ ▲

▲ ▲

▲ ▲

▲ ▲

INDIVIDUAL EQUIPMENT

SAFETY CONTINUED

First aid kit

EQUIPMENT PACKAGE

SL 550 GRAND EDITION PACKAGE:

Nappa leather upholstery, Leather covered steering wheel & shift knob, panoramic vario-roof, 19" AMG bi-colour twin 5-spoke wheels, Prism pattern aluminum trim.

▲ Standard equipment Δ Optional Equipment ○ Optional as part of an option package — Not available

SL 550
AVANTGARDE EDITIONSL 63 AMG
AVANTGARDE EDITION

▲ ▲

Δ —

¹© 2011 SIRIUS Satellite Radio Inc. "SIRIUS," the SIRIUS dog logo and related marks are trademarks of SIRIUS Satellite Radio Inc. Complimentary 6 months of service included. Monthly subscription required for service thereafter. ²Not available on SL 550 GRAND Edition.

³First year's monitoring provided at no cost with subscription. Subscription is required for service to be active. TeleAid operates only where cellular and Global Positioning System coverage is available.

The finishing touches.

Added nuances and unique refinement is just what will make your SL-Class a distinctively richer automobile. Mercedes-Benz accessories are a cut above, having been designed and built to the highest standards for concept, engineering, quality, form and function.

Technical data:

	SL 550 AVANTGARDE AND GRAND EDITION	SL 63 AMG AVANTGARDE EDITION
Engine type	32V DOHC V8	32V DOHC V8
Total displacement	5,461 cm ³	6,208 cm ³
Net power	382 hp @ 6000 rpm	518 hp @ 6800 rpm
Net torque	391 lb-ft @ 2800-4800 rpm	465 lb-ft @ 5200 rpm
Acceleration ¹ , 0-100 km/h	5.4 seconds	4.6 seconds
Approximate top speed ²	210 km/h	250 km/h
Tires, front rear	255/35 R 19 285/30 R 19	255/35 R 19 285/30 R 19
Fuel economy ³ , city/highway estimate	15.6-9.7 L/100 km	17.9-10.6 L/100 km
Fuel tank capacity	80 L (with 10 L reserve)	80 L (with 10 L reserve)
Fuel requirement	Premium unleaded gasoline	Premium unleaded gasoline
Dimensions ⁴		
Wheelbase	2,560 mm	2,560 mm
Overall length	4,562 mm	4,605 mm
Overall height	1,295 mm	1,295 mm
Overall width – Mirrors Extended	2,069 mm	2,069 mm
Curb weight	1,915 kg	1,995 kg
Luggage capacity	288 litres	288 litres

¹Stated rates of acceleration are based on the manufacturer's track results and may vary depending upon model, environmental and road surface conditions, driving style, elevation and vehicle load. ²Electronically limited. ³These estimates are based on Transport Canada testing methods. Estimates for the SL 550 AVANTGARDE AND GRAND Edition & SL 63 AMG AVANTGARDE Edition are based on 7G-TRONIC models. The actual fuel consumption of these vehicles may vary. Refer to the *Fuel Consumption Guide*. ⁴Dimensions shown are for models with standard equipment.



The custom Car Cover will protect your SL-Class from all the elements.



This shallow Trunk Tray is precision tailored, and made from non-slip materials. Keep your trunk clean, and protect it against spillage.



Precision designed chrome pieces help round off the SL's chrome accents, while protecting your paint from scratches.



High quality, two-piece door sill panels made from brushed stainless steel. The white illuminated Mercedes-Benz lettering is activated every time you open the door to get in or out.

A passion for things done right.

It's what you expect from Mercedes-Benz. A passion for craftsmanship and attention to detail is what sets Mercedes-Benz apart from all other manufacturers. This passion drives us to set new standards in design, performance, comfort and safety. To continually build on the legendary traditions of Mercedes-Benz, and to provide you with an ownership experience unlike any other, including the valuable benefits described below.

24-hour Roadside Assistance

During the basic warranty coverage of 48 months and the time duration of the optional Extended Limited Warranty, Mercedes-Benz Roadside Assistance will be at your service. We'll bring you some gas, replace a flat tire with your spare, or jumpstart your car. In the event of a mechanical breakdown, if attempts by our Roadside Assistance technician have not made your vehicle safely operable, towing service will be provided to the nearest Mercedes-Benz dealership. Assistance is available 24 hours a day, every day, to anyone driving a Mercedes-Benz anywhere in Canada or the continental U.S.¹

Wear and tear period

The following parts listed are covered for wear and tear during the first 24 months or 40,000 km, whichever comes first. Brake pads, brake discs, brake pad wear sensors and light bulbs.

Mercedes-Benz warranties

The Mercedes-Benz New Vehicle Limited Warranty covers defects in materials or workmanship for 48 months or 80,000 km, whichever comes first. To widen your window of confidence, you can opt for a Mercedes-Benz Extended Limited Warranty as well.²

Customer service

Owning a Mercedes-Benz means that when you have a question, we're here to help. Customer Service is open from 9 a.m. to 5 p.m. EST, Monday through Friday, and is staffed with knowledgeable Mercedes-Benz people who can talk you through the finer points of working your car's audio system – or even assist you in locating the nearest Mercedes-Benz dealership. Just call 1-800-387-0100. It's that simple.

Trip interruption reimbursement

If a breakdown covered by your New Vehicle Limited Warranty or optional Extended

Limited Warranty occurs more than 80 km from your home, leaves your Mercedes-Benz vehicle inoperable or unsafe to drive, and requires overnight repairs, we've got you covered. You will be reimbursed up to \$500 for hotel accommodations and up to \$600 for alternative travel expenses per incident while your car is being repaired at an authorized Mercedes-Benz dealership.

¹Vehicle must be accessible from main roads. Roadside Assistance may involve charges for parts, service and towing. Depending on the circumstances, these services may be provided by an outside service provider, courtesy of Mercedes-Benz Roadside Assistance. For full details of the Roadside Assistance Program, please see your dealer. ²Please see your dealer for warranty details as well as for terms, conditions and pricing for extended warranty options.

Mercedes-Benz is virtually yours.

Visit mercedes-benz.ca and open an online window to Mercedes-Benz Canada. Revel in the incredible photography of our vehicles and get a visceral impression of what it would be like to see yourself behind the wheel. Access information about any of our vehicles, including financing and leasing options, upcoming models, and configure your dream Mercedes online. Our website also offers details about the Mercedes-Benz Extended Limited Warranty, vehicle ownership, and much more on the fascinating story behind one of the world's most recognizable brands.

To be continued. With a test drive.

Nowhere is your SL-Class so convincing as on the road. It's only there that you can fully experience the superior handling and power that makes this car so special. Feel the engine move you forward, and watch your heart rate rise with the speedometer. That unique feeling in your stomach cannot be put down on paper. That's why we would like to invite you in for a test drive at your local Mercedes-Benz dealer. Reserve your appointment today, or visit mercedes-benz.ca. We look forward to seeing you.



© 2011 Mercedes-Benz Canada Inc.

All illustrations and specifications contained in this brochure are based on the latest product information available at the time of publication. Mercedes-Benz Canada reserves the right to make changes at any time, without notice, in colours, materials, equipment, specifications and models. Any inaccuracies in colours shown are due to reproduction variations of the printing process. Some vehicles may be shown with non-Canadian equipment. Some vehicles may be shown without side marker lights. Some vehicles are shown with optional equipment available at extra cost. Some optional equipment may not be available on all models. For current information regarding the range of models, standard features, optional equipment and/or colours available in Canada and their pricing, contact your nearest authorized Mercedes-Benz dealer or visit mercedes-benz.ca. harman/kardon® and LOGIC7® are registered trademarks of Harman International Industries Inc. iPod® is a registered trademark of Apple Computer, Inc.

Printed in Canada
MBC-11-SL12-2900E

Mercedes-Benz Canada Inc. 98 Vanderhoof Avenue, Toronto, Ontario M4G 4C9
1-800-387-0100

www.mercedes-benz.ca

