



SLK-Class

Mercedes-Benz

From the Mercedes-Benz dream factory

Contents

The SLK	4	My SLK	44
Agility	6	Equipment & appointments	46
Exterior design	6	Sports package	46
Driving dynamics	14	Standard equipment	48
Vario-roof	16	Optional extras	50
BlueEFFICIENCY	18	Light-alloy wheels	52
Petrol engines	20	Audio and communication systems	54
Transmissions	24		
		Genuine accessories	58
Safety	26	designo	60
Active safety	26		
Passive safety	28		
		Colours and materials	62
Comfort	30	Paintwork	62
Interior design	30	Upholstery and trim parts	64
		Combination options	66
COMAND APS	36		
		Technical data	68
AMG	38	Dimensions	69
SLK 55 AMG	38	Services	70
AMG Performance Studio	40		
AMG optional extras	42		

Start measuring time a new way

Ever since Einstein we have known that neither time nor space are absolute dimensions. Time can drag by ever so slowly, for example when you are waiting for something much longed-for, whereas in moments of happiness it feels as if it literally flies by. Seen from this perspective, the SLK is something of a time machine. A roadster and at the same time a full-blooded coupé, created so you can experience each moment as intensely as possible. Come along for a little time travel and become part of this fascinating car's success story.

The SLK





From 0 to absolute fascination in 0.1 seconds flat

Exterior design

First impressions count, and are seldom reconsidered. One glance is all it takes for the brain to make a split-second, instinctive decision. Now, if it's fascination at first sight the moment you see the SLK, this could be due to its classic roadster proportions with short overhangs and a dynamically styled front end, together with

the sporty looks of the light-alloy wheels. Whatever the reason, one thing is certain: a lot has been said and written about designing cars. And a lot of verbose expositions have been made about this or that formal idiom, or these or those flowing lines. But in all honesty – one look at the SLK says it all.









As time goes by, fascination turns into a lasting captivation

Exterior design

Its very design makes you want to set it in motion. With its beguiling looks, the SLK forms a thoroughly impressive package from tip to toe. It goes without saying, of course, that the tail end of the SLK is every bit as eye-catching as its striking front, courtesy of distinctive tailpipes, the bumper with a hint of a diffuser at the bottom, as well as the dark-tinted tail lights. Consequently, the instant you set eyes on the SLK, you will feel an urge... to get behind the wheel.











Discover the joy of the perpetual perfect moment

Agility

You are enjoying the exhilarating acceleration and the incomparable sensation of open-top motoring: there are moments when absolutely everything seems perfect. Those are precisely the occasions for which we built the SLK. Then, time somehow seems to go faster, so that even driving great distances becomes an enthralling experience because of its intensity. Effortlessly superior agility, dynamism you can feel, plus remarkably precise handling with the optional Direct-Steer system all allow you to experience sportiness in an entirely new way aboard this timelessly beautiful roadster. Every single day, should you wish.

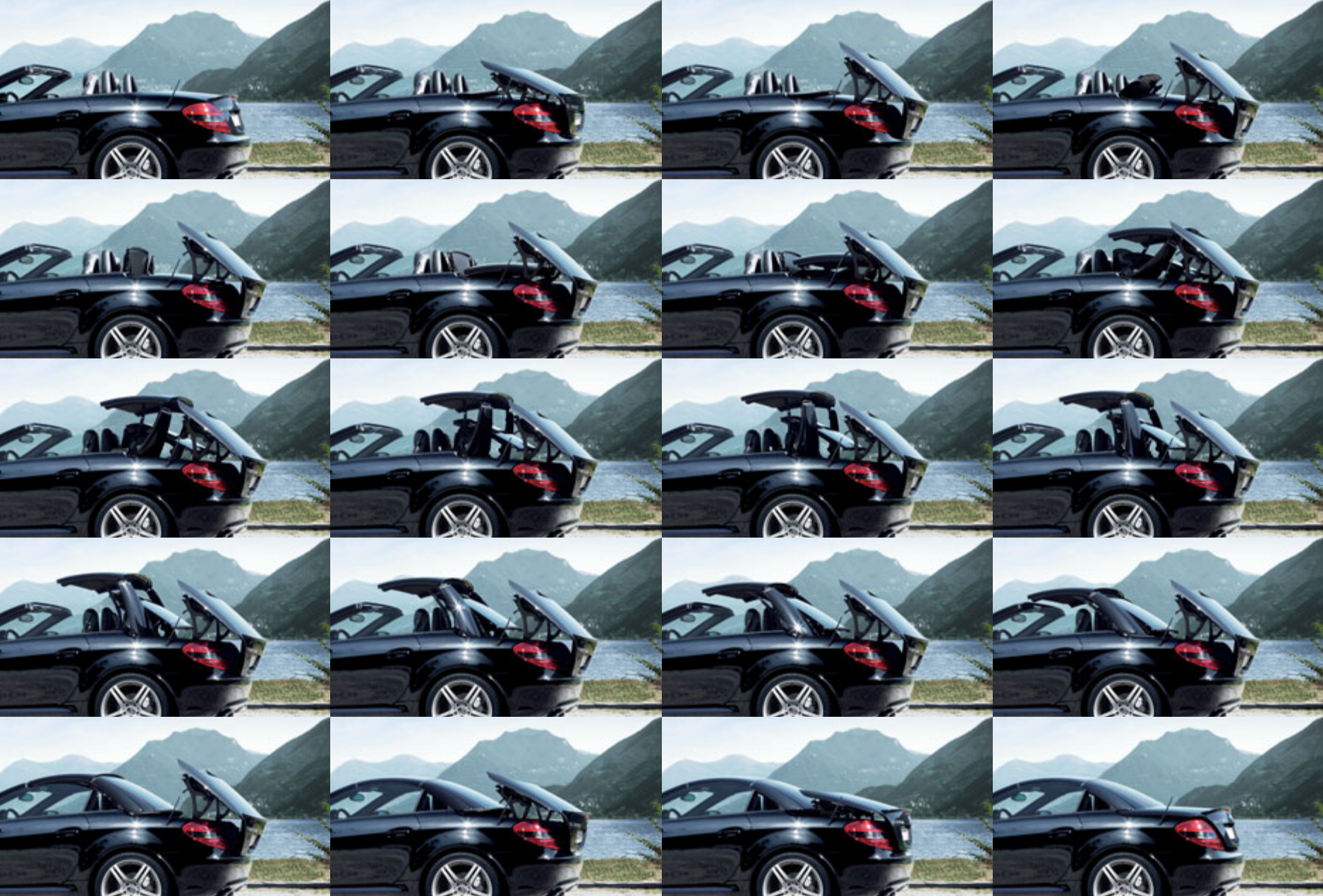

Infinite headroom, instantly! With the vario-roof, which made its first ever appearance on an SLK. Pressing a button is all it takes for the vario-roof to disappear into the boot in 22 seconds. In the closed position, you will benefit from the pleasant noise insulation it provides, and the reassuring feeling of having a solid roof over your head. With the roof lowered, the SLK boasts 208 litres of luggage capacity; with the roof raised, even more: 300 litres.

In order to prevent irritating airflow turbulence in the neck region from diluting the roadster sensation when driving with the top down, you have a choice of two optional draught-stop systems.

And if you are looking to drive with the roof open even when the warm summer days are a distant memory, you will be thrilled with the AIRSCARF neck-level heating system, which has been developed specially by Mercedes-Benz. Here, air flowing out of the head restraint provides warmth in the head and neck region, enabling you to enjoy the roadster season all year long, if you so desire.



BlueEFFICIENCY – innovations for efficient mobility

We do not pay lip service to protection of the environment. It's a matter close to our hearts. As the inventor of the motor car, Mercedes-Benz has a special responsibility – one we have undertaken with all our might for many years. We can already offer you 66 models that place far less of a burden on the environment – without having to compromise on safety, comfort and driving enjoyment.

Our BlueEFFICIENCY concept comprises innovations for efficient mobility as well as optimised processes all the way along the value chain. They involve different approaches, but they all have a common goal: to make your individual mobility as sustainable as possible.

The BlueEFFICIENCY measures – the Mercedes-Benz efficiency package. The BlueEFFICIENCY measures are comprehensive vehicle optimisations which save fuel and, therefore, ease the burden on the environment. Each model combines the most efficient engine with optimal aero-

dynamic and energy-management measures to minimise fuel consumption. Such measures include intelligently controlled ancillaries, tyres with optimised rolling resistance, the ECO start/stop function, lightweight components and an aerodynamically optimised body design. All in all, these measures allow substantial savings to be made: fuel consumption and, therefore, CO₂ emissions are reduced by up to 23 %.

BlueTEC – the clean diesel. Mercedes-Benz has brought to market BlueTEC technology for diesel



The BlueEFFICIENCY measures bring about a substantial reduction in fuel consumption and CO₂ emissions

engines based on common-rail direct injection (CDI). It combines optimised combustion with a modular emission-control system, all of which makes BlueTEC an exceptionally clean diesel technology. Not only does it remove up to 95 % of the particulate from the exhaust gases, it also reduces nitrogen oxides by up to 90 %. All that remains is water, harmless nitrogen and the satisfying feeling of having helped to ease the burden on the environment.



BlueTEC filters out up to 95 % of the particulate and converts up to 90 % of the nitrogen oxides into harmless nitrogen

HYBRID – the intelligent combination of petrol and electric drive. A well-established team makes a lot of things easier. And this is certainly true in the case of HYBRID technology. During braking, the electric motor supplies the battery with kinetic energy. When needed, this energy is forwarded to the electric drive, which assists the petrol engine when the car is accelerating. What's more, the ECU shuts off the petrol engine when the speed falls below 15 km/h. In this way, a HYBRID can reduce fuel consumption by up to 20 %. So it looks after the environment as well as your bank balance. Perfect teamwork, you might say.



HYBRID technology reduces fuel consumption by up to 20%

BlueTEC HYBRID – clean diesel combined with electric drive. BlueTEC HYBRID technology marries the benefits of HYBRID technology with those of BlueTEC technology: during braking, the kinetic energy is converted into electrical energy, which can be re-used when required. At the same time, the BlueTEC technology cleans the exhaust gases and removes most of the pollutants.

Innovative drive systems that break new ground. Concept BlueZERO F-CELL, E-CELL and E-CELL PLUS. Mercedes-Benz has developed three further drive concepts with an electric motor and a bat-



BlueTEC HYBRID combines clean diesel technology with electric drive, and will be available from 2012

tery for storing energy as part of its close-to-production Concept BlueZERO: E-CELL with an electric motor, which only draws its energy from the battery; E-CELL PLUS with a battery and an internal combustion engine (Range Extender); and F-CELL with an additional fuel cell for generating power.

But that is not all: under the banner “Design for Environment”, we also look at a vehicle's entire lifecycle – from planning to recycling. The same applies to the building and running of new factories. In addition, Mercedes-Benz is involved in the development of alternative fuels and carries out research in the field of bionics. In short, BlueEFFICIENCY is good news for both you and the environment.

Further information about our comprehensive measures can be found at:
www.mercedes-benz.com/blueefficiency

High time for a most powerful argument

The SLK 350 sports engine

More than enough power for getting away from it all. The SLK offers you the widest choice of engine outputs in its class. The engines all have one thing in common: they turn every drive in your SLK into a most moving experience, and, thanks to the vehicle's generously-sized 70-litre fuel tank and the resulting range, you can revel in it at great length.

Take the lively SLK 350 sports engine, for instance.

This 6-cylinder unit just loves to accelerate the car, with a formidable 224 kW at its disposal, and truly makes its mark with a high-revving design that permits engine speeds of up to 7200 rpm. What's more, it delivers a thrilling sound that truly gets under your skin over the entire rev band, as well as power galore for tasting pure driving bliss. One final thing worth mentioning is that, despite the tremendous power output, our engineers have actually succeeded in cutting both the engine's fuel consumption and its pollutant emissions.

SLK 350 sports engine

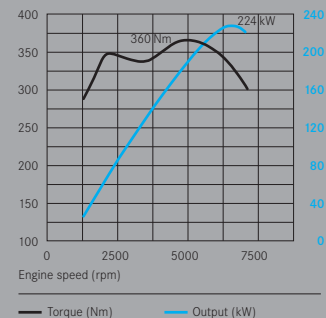





A temperament to suit all tastes

The SLK 200 KOMPRESSOR and the SLK 300

Delivering an output of 135 kW, the SLK 200 KOMPRESSOR propels the SLK along in agile, dynamic fashion, while delighting with its understated yet resonant sound. The SLK 300 promises an even sportier drive, mustering up as it does 170 kW from its displacement of 2996 cc. And thanks to its uniform power delivery and impressive refinement, the SLK 300 succeeds in fusing motoring comfort with motoring pleasure.

To continue as the leaders of tomorrow, it is vital to think in terms of sustainability today. That's why we have significantly reduced the CO₂ emissions and fuel consumption of the engines detailed here, in spite of their impressive output figures. Please refer to page 68 for more information on fuel consumption and CO₂ emissions.

SLK 200 KOMPRESSOR

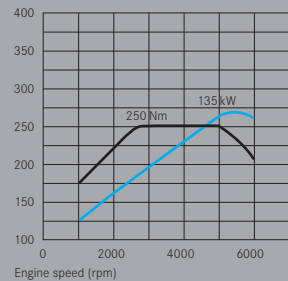

SLK 300

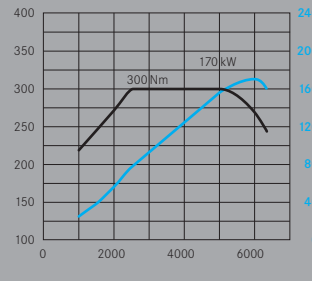

— Torque (Nm) — Output (kW)



As precise as a Swiss watch – and saves fuel too

The transmissions

The SLK stands for responsiveness and agility of the highest degree. And if you move fast, you must be able to shift fast, too. That's why the power of the various engines is transferred by transmissions which are precisely attuned to the temperament of each model. You can choose between the standard 6-speed manual transmission and an optional 5-speed automatic transmission for the SLK 200 KOMPRESSOR. For those who prefer one of the 6-cylinder engines, 7G-TRONIC, the 7-speed automatic transmission, is available as an option. In the SLK 55 AMG, this transmission is standard. The optional

7G-TRONIC Sport with steering-wheel gearshift paddles ensures even swifter gearshifts. These steering-wheel gearshift paddles can be ordered as optional equipment for all automatic transmissions, and are included as standard on the SLK 55 AMG.

With its seven speeds, the 7G-TRONIC automatic transmission adapts marvellously to every driving situation. The seven ratios ensure that the jumps in rev speed from one gear to the next are small, resulting in smoother gearshifts and a lower average rev speed level. In addition, it offers the possibility of multiple downshifts for extra-fast acceleration at any time



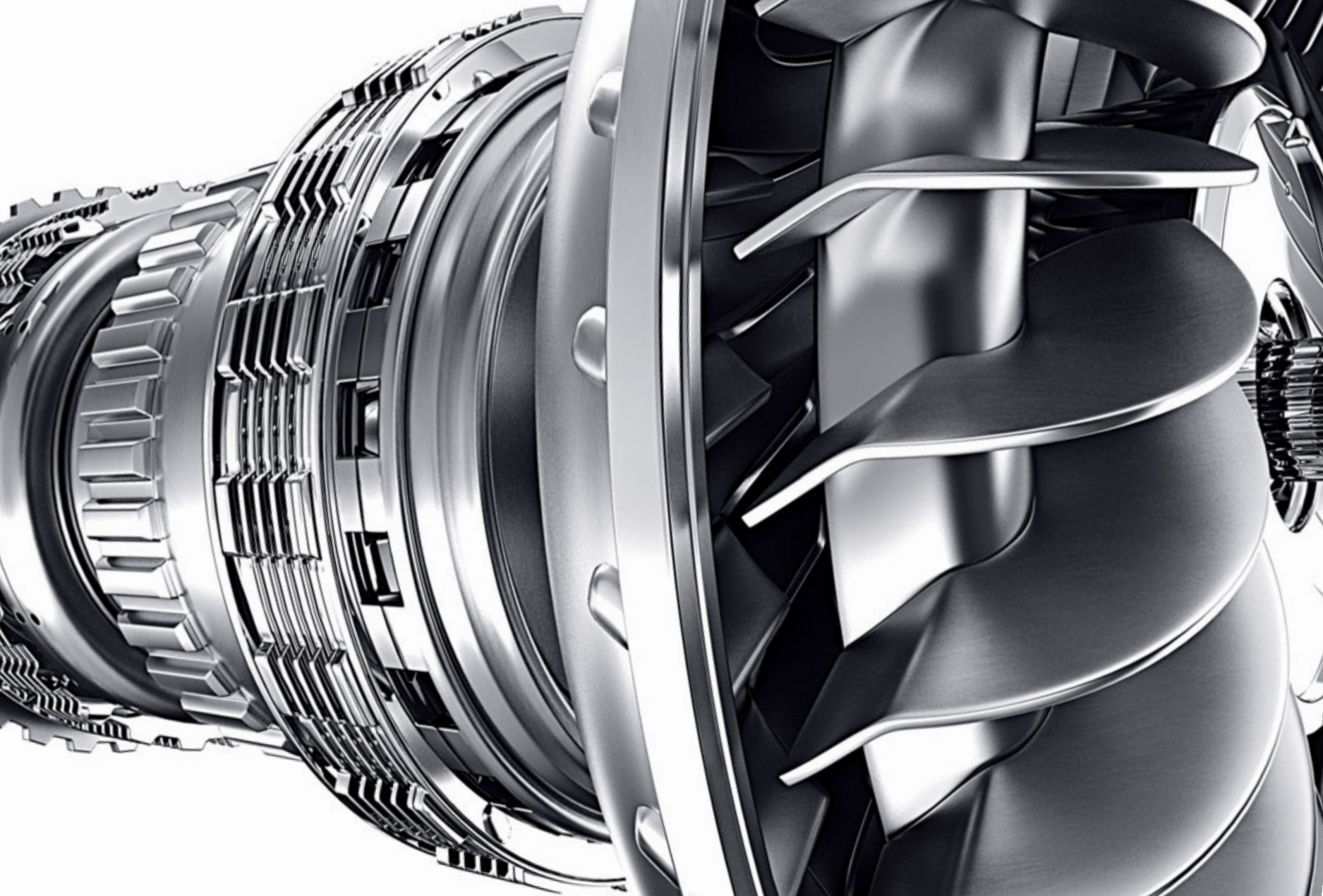



SLK 300



S 0T 9481



When your safety is at stake, the SLK takes action in an instant

Active safety

To prevent accidents from happening in the first place, a high level of active safety is built-in for undiluted driving pleasure. Your SLK is, of course, equipped with ESP® and BAS as standard. If the vehicle is at risk of entering a skid, ESP® helps to defuse the situation through targeted interven-

tions in the braking and engine management systems. Meanwhile, the electronic Brake Assist system detects emergency braking from the speed with which you press the brake pedal, whereupon it instantly builds up maximum braking power.

Years of research shows its worth in a split second

Passive safety

What might be awaiting you around the next bend? There may indeed be questions for which no safety system yet has the answer, but in practically all other situations you can rely on the SLK's intelligent safety concept. Should the worst come to the worst, you will be protected by belt tensioners as well as adaptive driver's and passenger's airbags. The SLK is equipped with head/thorax sidebags too. These are located in the outside edges of the seat backrests, and together with the roll-over sensor, they afford

the best possible occupant protection in the event of a lateral collision or of the vehicle overturning. All these systems have been integrated in an extremely torsionally-rigid passenger safety cell which, in combination with the roll-over bars built into the vehicle body, ensures you always keep on the safe side in spite of all the vehicle's openness. Added to this is the fact that the robust steel construction of the vario-roof when closed offers even greater safety.



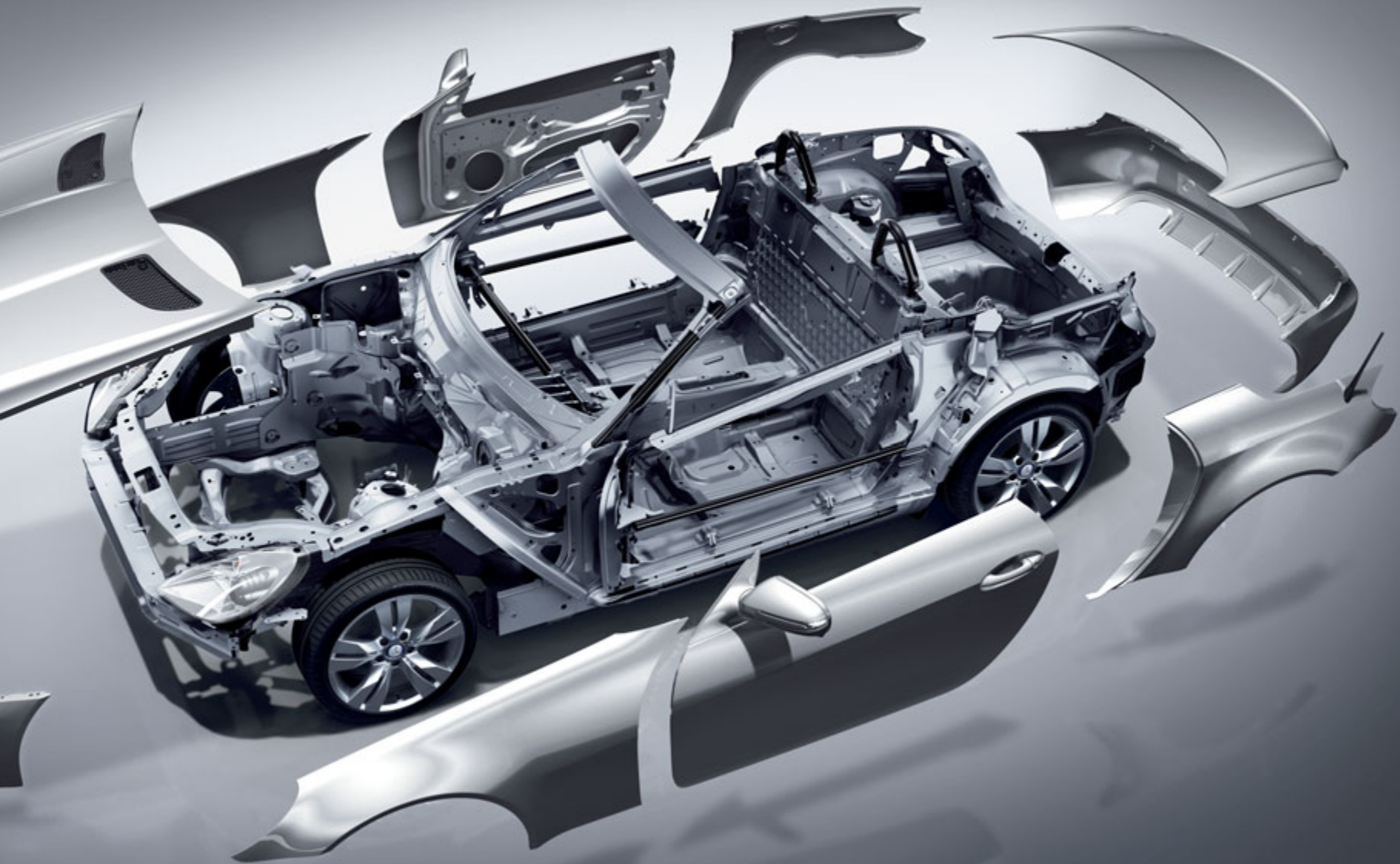

Ergonomics can either be explained at length, or felt at once

Interior design

If you want to have fun, you have no time to waste. That's why it is good if all the controls and displays are not only crafted with the highest



The 3-spoke sports steering wheel trimmed in nappa leather features practical multifunction buttons as standard

degree of workmanship, but are also placed just where you would intuitively expect them to be. Because that is the only way to have the reassuring feeling of being in direct control of the vehicle: a control so powerful and intense that it makes you feel at one with the vehicle's technology. The sports steering wheel trimmed in supple nappa leather with standard-fit multifunction buttons feels good in your hands, while the interior can be given a particularly refined air by opting for the exclusive wood trims in a choice of light burr walnut and black ash. Positioned directly in your field of vision to keep you constantly informed of all key data is the instrument cluster, which stands out for its understated good looks with red needles, elegant dial bezels in a 3D look, plus tubes with chrome surrounds.

USE APPROPRIATE SPEED
FOR YOUR AREA
© 2011
SAAB



FM 4

↑
SWR3
↓

+23.0 °C



Open for spontaneous decisions

Interior design

The interior of the SLK is the perfect place for enjoying yourself. Awaiting you here is a stylish symbiosis of out-and-out sportiness on the one hand and, on the other, a degree of space and comfort which is otherwise unheard of in this segment. The result is a clear enhancement of motoring pleasure. The optional leather appointments allow you to give your SLK an even more exclusive look: you can choose from leather in black, alpaca grey, orient beige or gullwing

red. And anyone looking for an even greater air of refinement can opt for the luxurious nappa leather appointments: here, the seats are upholstered in finest nappa leather in either black or natural beige, and even the centre armrest is trimmed in soft black nappa leather, complete with elegant topstitching. Whatever you decide on, you can be sure of exceptional build and material quality. The SLK is, after all, one thing above all else: a Mercedes.





Mercedes-Benz



Sport has seldom been so relaxing

Driving comfort

This is just how comfortable sporty motoring can be. You will start to appreciate the excellent lateral support of the dynamically contoured seats with their magnesium frame on your very first outing. Then there is the spontaneous, agile handling of the optional Direct-Steer system with variable servo assistance, which is unrivalled in this segment and positively invites you to power through bends in the road. Thanks to the outstanding suspension tuning, even longer journeys are nothing less than an absolute delight. You also have the option of the innovative AIRSCARF neck-level heating system: by delivering pleasantly warm air from the head restraints it allows you to extend the cabriolet season at the touch of a button. And to maintain a refreshing climate when the roof is up too, there is either the air

conditioning system that comes as standard in the SLK 300, SLK 350 and SLK 55 AMG, or the optional THERMOTRONIC luxury automatic climate control featuring automatic regulation of the air distribution, plus solar and air quality sensors.

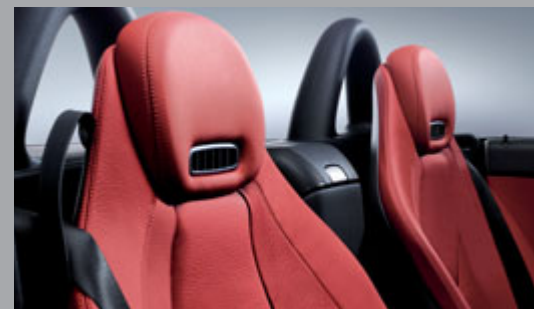

The innovative AIRSCARF neck-level heating (optional) can keep your head and neck snug and warm



RADIO

DISC

NAVI

TEL



SYS



ON

11:47

TA

T-Mobile D

Navi Audio Tel Video System

1. SWR1 BW

• 101.3 MHz

3

SWR3

2. SWR2 BW

4. 102.3 MHz

Radio

Speicher

FM

Klang

1

2

3

QW

ABC

DEF

4

5

6

GHI

JKL

MNO

7

8

9

PGRS

TUV

WXYZ



OK



If you wish, your SLK can listen to your every word

Ease of operation

At last! A car that understands you. This is because you have the option of the sophisticated COMAND APS multimedia system. The system's intuitive user guidance makes it more user-friendly than ever, despite its vast array of functions. The COMAND APS features a fast hard-disc navigation system including a 3D display, a MUSIC REGISTER for storing audio files, plus a high-resolution 6.5-inch colour display, to name but a few of the highlights. The entire system can be operated from an ergonomically positioned control pad. What's more, the SLK can also be ordered with the voice-operated control system LINGUATRONIC for operating the audio, telephone and navigation systems. The system is al-

ready contained within the COMAND APS and can also be added to the optional Audio 50 APS, if you wish.



The multifunction buttons allow you to control many of the COMAND APS system's functions directly from the steering wheel

AMG. Three letters – one clear statement

The SLK 55 AMG

You can see it immediately just from the outside: this is as SLK as it gets. Because the SLK 55 AMG interprets the sporty, elegant look of the classic roadster more assertively and uncompromisingly than ever. And it lives up to this exterior promise in every way by delivering true sports car performance. Under the bonnet, an AMG V8 engine with a displacement of 5.5 litres generates a



breathtaking 265 kW and a maximum torque of 510 Nm. The SLK 55 AMG sprints from 0 to 100 km/h in 4.9 seconds. More than sufficient to press you with pleasant firmness back into the exclusive AMG nappa leather sports seats. The SLK 55 AMG is equipped as standard with the innovative AMG SPEEDSHIFT 7G-TRONIC, which permits extra-swift gear-shifting. The transmission can also be controlled by means of the steering-wheel gearshift paddles on the AMG sports steering wheel trimmed in nappa leather. Further highlights of the extensive high-performance specification of the SLK 55 AMG are the AMG sports suspension and the 18-inch AMG multi-spoke light-alloy wheels in a high-sheen, titanium grey-painted finish that are exclusive to this model.







If the only sports that count for you are high-performance sports

The AMG Performance Studio

For even more dynamic driving, there are exclusive optional extras available for the SLK 55 AMG from the AMG Performance Studio. Here, for instance, you can opt for the multi-piece 18-inch twin-spoke AMG light-alloy wheels, an AMG performance suspension, as well as AMG carbon-fibre trim elements and the AMG performance steering wheel

trimmed in nappa leather, with its flattened lower section and smaller rim diameter. For ultimate motoring pleasure there is the highly attractive AMG Performance package, which comprises an AMG high-performance compound brake system in addition to the features mentioned above.



Where would an athlete be without the right outfit?

The optional AMG bodystyling and 18-inch AMG light-alloy wheels

If you don't want to go for the SLK 55 AMG right away, you still have the option of underlining the SLK's sportiness to striking effect with AMG bodystyling. This package, created by Mercedes-AMG and consisting of dynamic-looking AMG aprons at the front and rear as well as muscular side skirts, lends the SLK a particularly athletic look.

In addition, the AMG spoiler lip neatly rounds off the exterior design, at the same time enhancing downforce and thus handling stability. Optionally, all SLK models can be fitted with high-sheen 18-inch twin-spoke AMG light-alloy wheels, shod with 225/40 R 18 tyres at the front and 245/35 R 18 tyres at the rear.









My SLK

The most beautiful combination of sports and aesthetics

The SLK with the Sports package

Sportiness lies in the nature of the SLK. And the optional SLK Sports package allows you to elicit this temperament to stunning effect. The extensive package includes headlamp linings in a matt grey finish, as well as 18-inch 5-twin-spoke light-alloy wheels in titanium silver, which lend yet greater emphasis to the car's dynamic appearance.



The striking perforated brake discs at the front provide extra reserves of stopping power, while the AMG spoiler lip on the tail generates even greater downforce at the rear axle. A sports suspension is likewise fitted as standard, and steering-wheel gearshift paddles are also included for models with the optional automatic transmission.



Yet the Sports package can be admired equally as well from the interior. Here you will find a black roof liner, red seat belts (optionally available in black), plus red topstitching on the seats, armrest, steering wheel and gearshift lever. Attractive carbon-look trim parts and floor mats with red edging round off the interior concept of the Sports package in style.







The roll-over bars offer added protection if the worst comes to the worst



Cruise control makes for more relaxed motoring and can also reduce fuel consumption



The 3-spoke sports steering wheel trimmed in nappa leather with multifunction buttons as standard



The dark-tinted tail lights add to the sporty looks



Front fog lamps ensure clear visibility even in the most dreary weather



The shorter rod aerial is suitable for use in automatic car washes

Standard equipment (selection)

16-inch 7-spoke light-alloy wheels ¹
3-spoke sports steering wheel with multifunction buttons
6-speed manual transmission ²
Adaptive front airbags and head/thorax bags (enlarged sidebag providing additional head protection) for driver and passenger
Air conditioning system including dust filter and activated charcoal filter ³
Anti-lock braking system (ABS)
ASSYST PLUS service interval indicator with service computer
Audio 20 CD (with 5-inch colour display, MP3 capability and Bluetooth® hands-free system)
Automatic heating and ventilation system with dust filter and air recirculation button with convenience feature (automatic window closing)
Automatic seat occupancy sensor/child seat recognition system in passenger seat
Aux-in socket in glove compartment (omitted if optional media interface is ordered)
Belt tensioners with belt force limiters
Chrome-effect electronic key
Cruise control with SPEEDTRONIC variable speed limiter
Dark-tinted tail lights
Driver and passenger seats height-adjustable
Electrohydraulic vario-roof, in vehicle colour, with heated rear windscreen
Electronic immobiliser with locking system and radio remote control
Electronic Stability Program ESP®

Folding armrest with compartment
Front fog lamps, one rear fog lamp
Indicator lamps in exterior mirrors
Interior lighting switch-on after accident
Power socket (12 V) in passenger footwell
Power steering and safety steering column
Remote boot lid release
Roll-over bars for driver and passenger
Short rod aerial, suitable for use in automatic car washes
Sports seats with magnesium backrest (folding) and integral head restraint
Steering column manually adjustable for height and reach
Stowage box on rear panel between seats
Stowage net in passenger footwell
Tinted windows all round
TIREFIT tyre sealant with electric pump
Trapezoidal-section tailpipes

¹ 16-inch 5-spoke wheels for SLK 300, 17-inch 5-twin-spoke wheels for SLK 350 sports engine, 18-inch multi-spoke wheels for SLK 55 AMG

² 7G-TRONIC automatic transmission standard for SLK 55 AMG

³ Available for SLK 200 KOMPRESSOR as an option



Thanks to the innovative AIRSCARF neck-level heating, you can enjoy open-top motoring without having to endure chilly temperatures in the head and neck region



The 3-spoke sports steering wheel is optionally available with shift paddles for changing through the gears manually



The THERMOTRONIC luxury automatic climate control with automatic air distribution regulation



The electric seat adjustment control reproduces the shape of the seat, making it particularly user-friendly

Optional extras (selection)	SLK 200 K	SLK 300	SLK 350	SLK 55 AMG
4-way adjustable lumbar support for driver and front passenger	●	●	●	–
5-speed automatic transmission	●	–	–	–
7G-TRONIC automatic transmission	–	●	●	○ ²
AIRSCARF neck-level heating with fabric draught-stop	●	●	●	●
AMG bodystyling	●	●	●	○
Anti-Theft Protection package: anti-theft alarm system (ATA) with tow-away protection and interior monitoring	●	●	●	●
Audio 50 APS (as Audio 20 CD, with additional DVD arrow-based navigation and Junction View)	●	●	●	●
Battery with increased capacity	●	○	○	○
Bi-xenon headlamps with headlamp cleaning system, dynamic range adjustment and cornering light function	●	●	●	●
COMAND APS multimedia system for audio, navigation and telephone, incl. high-resolution 6.5-inch displays, hard-disc navigation, MUSIC REGISTER and voice-operated control system LINGUATRONIC	●	●	●	●
Direct-Steer system with variable servo assistance	● ³	●	●	○
Harman Kardon® Logic 7® surround sound system with Dolby 5.1/DTS	●	●	●	●
Heated windscreen washer system	●	●	●	●
Interior Light package	●	●	○	○
Lowered sports suspension	● ³	●	●	–
Luxury automatic climate control THERMOTRONIC	●	●	●	●
Media interface, e.g. for MP3 player, iPod® and USB stick	●	●	●	●
Memory package: electrically adjustable seats with memory function as well as exterior mirrors with parking position, steering wheel that adjusts to aid entry/exit and crash-responsive exit aid	●	●	●	●
Mirror package: automatically dimming interior mirror and exterior mirror on driver's side as well as electrically folding exterior mirrors left and right	●	●	●	●
PARKTRONIC	●	●	●	●
Sports package	●	●	●	–
Steering-wheel gearshift paddles ¹	●	●	●	○ ²

● Optional extra ○ Standard equipment

– Not available

¹ Only in conjunction with automatic transmission² AMG SPEEDSHIFT 7G-TRONIC with steering-wheel gearshift paddles standard for SLK 55 AMG³ Only in conjunction with mixed-size tyres

Make your mark before you even touch the ignition key

The light-alloy wheels

Light-alloy wheels are the calling card of any sporty car. Here you will find a wealth of suggestions for how to add a personal touch to your SLK.



16-inch 7-spoke light-alloy wheel
(standard for SLK 200 KOMPRESSOR)



16-inch 5-spoke light-alloy wheel
(standard for SLK 300, optional for SLK 200 KOMPRESSOR)



17-inch 5-twin-spoke light-alloy wheel (standard for SLK 350,
optional for SLK 200 KOMPRESSOR and SLK 300)



17-inch 5-twin-spoke light-alloy wheel
(only in conjunction with sports suspension)



17-inch incenio "Kikuchi" 5-twin-spoke light-alloy wheel



18-inch AMG multi-spoke light-alloy wheel in high-sheen,
titanium-grey painted finish (standard for SLK 55 AMG)



17-inch 10-spoke light-alloy wheel in "chrome shadow"
high-gloss painted finish



18-inch incenio "Korsunia" 5-triple-spoke light-alloy wheel



18-inch AMG twin-spoke light-alloy wheel, multi-piece
(optional for SLK 55 AMG)



18-inch 5-twin-spoke light-alloy wheel in titanium silver
(only in conjunction with Sports package)



18-inch AMG twin-spoke light-alloy wheel, high-sheen finish

Crystal clear and as impressive as the SLK itself

The Harman Kardon® Logic 7® surround sound system

If you would like to experience Dolby 5.1 digital sound in a class of its own, there is the option of the Harman Kardon® Logic 7® surround sound system with an output of 500 watts. This system has been specially developed for the SLK and delivers pure listening pleasure for both driver

and passenger through its eleven speakers. Regardless of whether the roof is up or down, or the recording is in stereo or 5.1: this is a high-end hi-fi system that is music to everyone's ears.

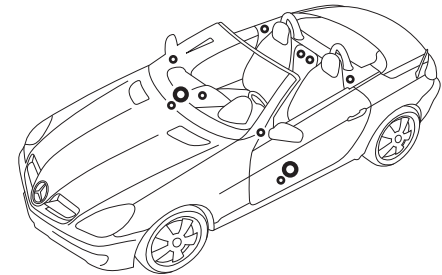

The clever arrangement of the speakers generates a sound field optimised specifically for the SLK, so you are able to enjoy a pristine sound at all times, even when driving with the roof down





AIRBAG

11:04 FM 92.2 MHz
DIE NEUE SWR4 5
SWR3
DKL TUR 89.3 MHz
Radio Speicher Klang



HAZARD OFF



Welcome to today's communication society. There are a number of audio and communication systems to choose from for your SLK. A common feature of all radio systems is the standard-fit Bluetooth® hands-free system. The range starts with the standard-fit Audio 20 CD featuring a 5-inch colour screen, built-in CD player with MP3 capability (can be upgraded to a built-in 6-disc CD changer) and an Aux-in connection in the glove compartment for connecting portable audio devices.

The Audio 50 APS supplements this with a DVD navigation system featuring an arrow-based display and Junction View. Anyone also opting for the built-in 6-disc DVD changer can enjoy the added luxury of the intuitive voice-operated control system LINGUATRONIC. This highly convenient means of control is included as standard with the COMAND APS, the innovative multimedia system with hard-disc navigation, including a 3D display and high-resolution 6.5-inch screens. In addition to this, COMAND APS comes with a MUSIC REGISTER, an SD memory card slot, plus a DVD video function.



The optional Audio 50 APS radio system can be upgraded to include a 6-disc DVD changer



The optional COMAND APS has a multimedia controller interface, allowing you to operate a host of functions with ease



Ready for the finishing touches

Genuine accessories from Mercedes-Benz

Nothing impresses quite like the real thing. With genuine Mercedes-Benz accessories you can make even more out of your SLK. Take, for instance, the optional three-piece draught-stop with a transparent perspex panel and the two plastic-framed mesh sections. These practical



The perspex draught-stop reduces airflow turbulence

accessories help reduce airflow turbulence in the neck area and can be attached between the roll-over bars in next to no time. You can create further highlights too by adding spoiler lips for the front apron, for example, or the 18-inch incenio "Korsunia" 5-triple-spoke light-alloy wheels



The cradles for mobile phones allow you to pair various phone models with the hands-free system

(pictured left). Exterior mirror housings and trim parts for the horizontal fins in the radiator grille and bumper – all in high-shine chrome – allow you to further enhance the dynamic appearance of your SLK.



The practical "New Alustyle Luxury" ski and snowboard rack can carry up to six pairs of skis or four snowboards

As individual as you are

The designo appointments

Custom-design your SLK as you please. Fine woods and exquisite leather upholstery – or combined leather and Alcantara® – with striking double topstitching give the interior an exclusive and highly individual flair. Matching

leather-covered trim parts and roll-over bars are available as an option. Further information can be found at www.mercedes-benz.com





The SLK paintwork puts the finishing touch to the carefully crafted Mercedes-Benz corrosion protection system, which includes zinc phosphating and electrophoretic dip priming stages for long-lasting protection. We also make very extensive use of eco-friendly water-based paints.

NON-METALLIC PAINTS



040 black



590 fire opal



650 calcite white

METALLIC PAINTS



197 obsidian black



230 indigolite blue



300 periclase green

SPECIAL PAINT FINISH



359 tanzanite blue

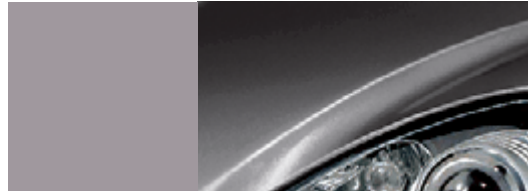

775 iridium silver



430 prehnite green



541 thulite red



792 palladium silver



755 tenorite grey

The seats of a Mercedes-Benz excel with a particularly high level of comfort, thanks to the special way in which the seat cushions are sprung and the use of separate foam elements for the centre panel of the seat cushion and the sides. The combination of the seat cushion spring set-up, which is precisely tuned to the vehicle, and the selection of the appropriate degree of cushion density results in exceptional springing and damping characteristics. To provide the perfect finishing touch, the seats are then upholstered in your own personal choice of fabric or leather.

FABRIC

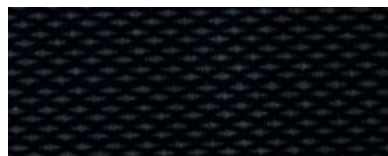
081 black¹

LEATHER

801 (851) black²808 (858) alpaca grey²815 (855) orient beige²817 (887) gullwing red²

¹ Standard specification

² Codes in brackets = standard nappa leather for SLK 55 AMG

³ Further designo appointments and information can be found at www.mercedes-benz.com

⁴ Available for the Sports package

NAPPA LEATHER



861 black

designo³ LEATHER, LEATHER/ALCANTARA[®]

X11 single-tone black

TRIM PARTS

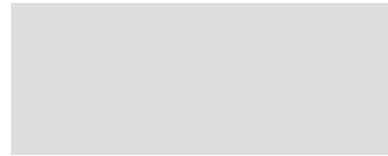
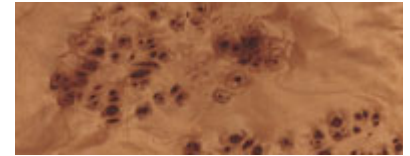
7H72 avus silver¹designo³ TRIM PARTS

W61 natural poplar



874 natural beige



X83 two-tone classic red



H12 light burr walnut



X20 single-tone black



736 black ash

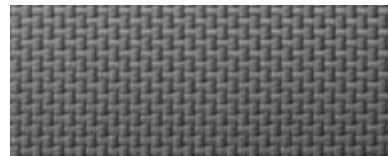

X21 single-tone alpaca grey

7K79 carbon fibre⁴

	FABRIC	LEATHER				NAPPA LEATHER	
	black	black	alpaca grey	orient beige	gullwing red	black	natural beige
NON-METALLIC PAINTS							
black	●	●	●	●	●	●	●
fire opal	●	●	●	○	●	●	○
calcite white	●	●	●	○	●	●	●
METALLIC PAINTS							
obsidian black	●	●	●	●	●	●	●
indigolite blue	●	●	●	●	△	●	○
periclas green	●	●	○	●	△	●	●
tanzanite blue	●	●	●	○	△	●	●
thulite red	●	●	●	●	○	●	○
tenorite grey	●	●	●	●	●	●	○
iridium silver	●	●	○	△	●	●	●
palladium silver	●	●	●	○	●	●	△
SPECIAL PAINT FINISH							
prehnite green	●	●	○	●	△	●	○

● Recommended

○ Possible

△ Not recommended

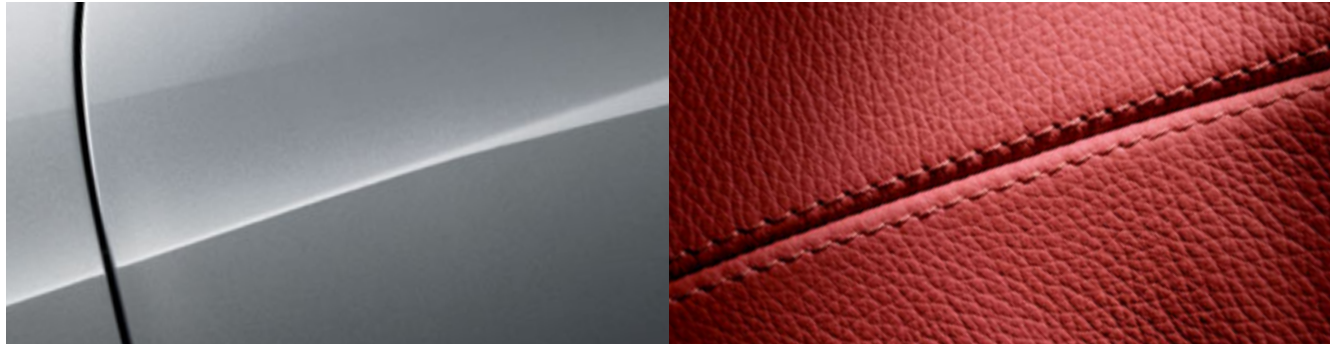

The combination of palladium silver metallic and gullwing red leather lends a particularly sporty flair



The combination of obsidian black metallic and black leather with red topstitching¹ also produces a most athletic look

¹ Available for the Sports package

	SLK 200 KOMPRESSOR	SLK 300 ⁶	SLK 350 sports engine ⁶	SLK 55 AMG ⁷
No. of cylinders/arrangement	4/in-line	6/V	6/V	8/V
Total displacement (cc)	1796	2996	3498	5439
Rated output ¹ in kW at rpm	135/5500	170/6000	224/6500	265/5750
Rated torque ¹ (Nm at rpm)	250/2800–5000	300/2500–5000	360/4900	510/4000
Compression ratio	8.5	11.3	11.7	11.0
Acceleration from 0 to 100 km/h (s) (automatic transmission)	7.6 (7.9)	6.3 (6.2)	5.4 (5.4)	– (4.9)
Top speed, approx. (km/h) (automatic transmission)	236 (232)	250 ² (250) ²	250 ² (250) ²	– (250) ²
Tyre size				
front	205/55 R 16 V	205/55 R 16 W	225/45 R 17 W	225/40 R 18
rear	205/55 R 16 V	225/50 R 16 W	245/40 R 17 W	245/35 R 18
Fuel	Premium petrol	Premium petrol	Premium petrol	Super Plus
Fuel consumption ³ (l/100 km) Urban/extra-urban/combined (automatic transmission)	11.0–11.2/5.7–6.0/7.7–7.9 (11.5–11.8/5.9–6.2/8.0–8.2)	13.9–14.1/6.8–7.0/9.5–9.7 (12.3–12.4/6.8–6.9/8.9–9.0)	14.5/7.0/9.7 (12.6/6.9/9.0)	– (17.7/8.8/12.0)
CO ₂ emissions ³ (g/km), combined (automatic transmission)	182–188 (190–196)	220–225 (207–209)	227 (209)	– (288)
Tank capacity (l)/incl. approx. reserve	70/9	70/9	70/9	70/9
Boot capacity (l) ⁴	300	300	300	300
Turning circle diameter (m)	10.51	10.51	10.51	10.51
Kerb weight ⁵ (kg) (automatic transmission)	1390 (1415)	1455 (1475)	1485 (1505)	– (1575)
Permissible gross vehicle weight (kg)	1705	1770	1800	1850

¹ Figures according to Directive 80/1269/EEC in the currently applicable version

² Electronically governed

³ The figures shown were obtained in accordance with the prescribed measuring process (Directive 80/1268/EEC in the currently applicable version). The figures are not based on an individual model and do not constitute part of the product offer; they are provided solely for purposes of comparison between different vehicle models

⁴ With closed vario-roof

⁵ Figures according to Directive 92/21/EC, version 95/48/EC (kerb weight with fuel tank 90 % full, driver, 68 kg, and luggage, 7 kg) for standard-specification vehicles. Optional extras and accessories will generally increase this figure and reduce the payload capacity accordingly

⁶ Meets requirements of EU 5 emission standard

⁷ Only available with automatic transmission

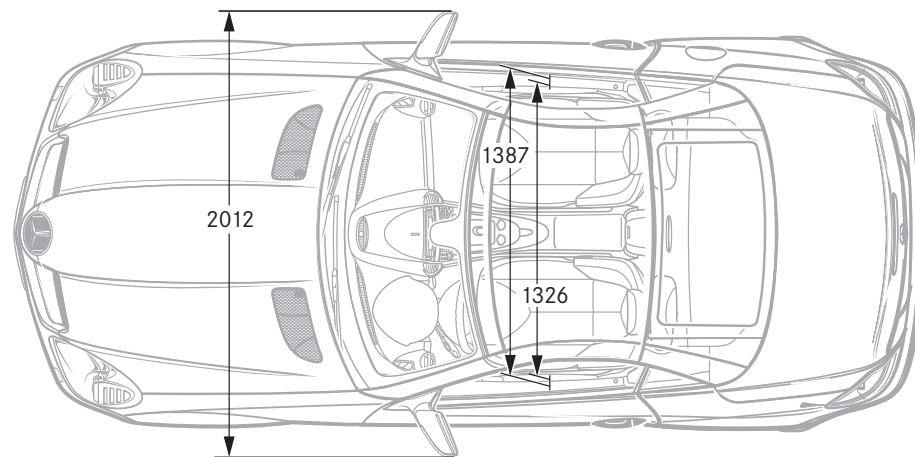
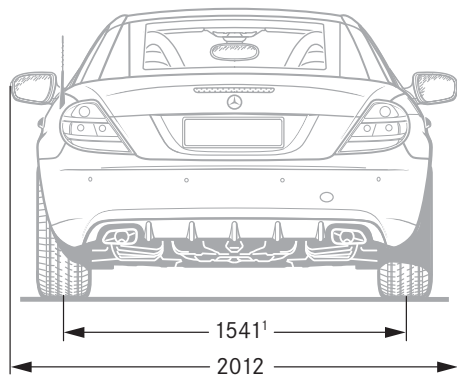
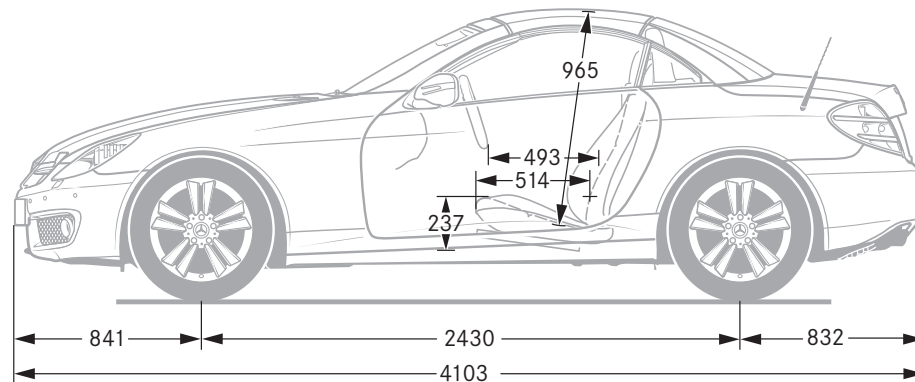
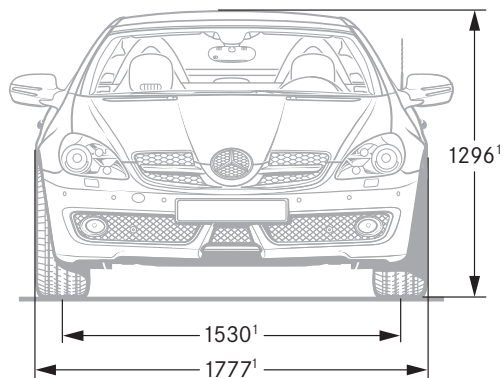

All measurements in millimetres. The dimensions shown are mean values and apply to standard-specification, unladen vehicles

¹ Dimensions apply to SLK 200 KOMPRESSION and may differ for other models



Anyone opting for a Mercedes buys far more than just a car

Mercedes-Benz mobility. There will always be a helpful passenger in your new car: the assurance of carefree driving. Should you ever need assistance, however, the Mercedes-Benz Service24h is there for you. Just call the freephone service hotline on 00800 1 777 7777¹. The newly integrated telematics service Mercedes-Benz Contact² is even more customer-friendly: a touch of a button is all it takes to contact the Mercedes-Benz customer centre by phone. And if you wish all the relevant vehicle and position-related data can be sent at the same time, ensuring the fastest possible reaction time and rapid on-the-spot help. As standard and at no extra charge: the Mercedes-Benz mobility package Mobilo³. Whether you have lost your key, have had a breakdown which cannot be repaired immediately or the vehicle is damaged as a result of an accident or vandalism, Mobilo gets you to your destination – anywhere in Europe. Whatever the nature of your problem, you will soon be able to resume your journey.

¹ Mobile phone rates vary according to service provider

² Requires a factory-fitted radio linked up to a switched-on mobile phone. For the cost of a call to the landline network

MercedesCard. Your ticket to the Mercedes-Benz experience: four times a year we will send you exciting details of a selected range of events and services which we have put together exclusively for you. Then there is the Mercedes Magazine with its fascinating reports and articles. But the MercedesCard also has many other uses: as a VISA credit card, it is an internationally accepted means of payment. Answer the annual questionnaire and we'll even waive the card fee. Plus the card offers further benefits to provide you with peace of mind, such as the Mercedes-Benz insurance package at no extra charge and the exclusively compiled MercedesCard insurance package at a preferential price. You can also gain free entry to the Mercedes-Benz Museum simply by showing your VISA MercedesCard. Further information can be found at www.mercedes-benz.de/mercedescard⁴

³ When the warranty has expired Mobilo can be extended by another year for a maximum of 30 years, provided that regular maintenance is carried out by your Mercedes-Benz service partner

⁴ Information about the MercedesCard in Austria and Switzerland can be found on the Mercedes-Benz websites for these countries

Mercedes-Benz Bank. If you have already chosen your dream car and want to remain financially flexible, you should make us your next port of call, whether it be for leasing, finance, insurance or service packages. Our “Private Leasing plus” scheme is a complete package comprising leasing, third-party insurance and fully-comprehensive insurance. “Business Leasing plus” for business customers works in much the same way, while our “Plus3 Financing” combines the low repayment rates of a financing scheme with the flexibility of leasing. You then have three options at the end of the contract: you can keep the car, sell it or return it to us for a guaranteed price and switch to a new model. We can also offer a range of investment products such as fixed-interest products, savings plans, investment funds or depository receipts. For details, please call 01803/32 22 65⁵ or visit www.mercedes-benz-bank.de

⁵ 9 ct./min. from Deutsche Telekom landlines, mobile-phone rates may vary



Time for another enriching experience

A Mercedes-Benz is most at home on the road. This is the only way to experience the effortlessly superior driving feel that lends every Mercedes model its inimitable class. Feel the power of efficient engines with low fuel consumption and precise steering, designed to put you right in the mood for driving. And experience what true comfort really is. The unique feeling of driving a Mercedes cannot be put into words, however. Which is precisely why we'd like to invite you to take a test drive. Your Mercedes-Benz dealer will be happy to make all the necessary arrangements for you. Simply visit www.mercedes-benz.com to locate the nearest Mercedes-Benz dealer in your country or region. We look forward to seeing you.

The website also offers an interactive tour, enabling you to take a closer look at your desired model. This simulation is the ideal way to acquaint yourself with your dream car. You can view key functions in detail, gain an insight into the car's inner workings or look at the benefits of each model. For further details, visit www.mercedes-benz.de/owners-manual

Now your mobile phone acts as a gateway to the whole Mercedes-Benz world. In addition to an overview of all passenger car models, there are insights into the entire brand world, not to mention a wealth of entertainment offers and direct links to a range of services at www.mercedes.mobi

Take-back of end-of-life vehicles. Coming full circle. At the end of its long life, you can return your SLK-Class to us for environment-friendly disposal in accordance with the EC End-Of-Life Vehicle Directive¹. But that day lies a long way off.

¹ Applies in accordance with national regulations to vehicles up to 3.5 tonnes gross weight. Mercedes-Benz passenger cars have met the statutory regulations governing the suitability of their design for reuse and recycling for a number of years now. A network of vehicle take-back depots and dismantlers has been established which will process your vehicle in an environment-friendly manner. The ways in which both vehicles and parts can be recovered are subject to ongoing development and improvement. Consequently, the SLK-Class will be able to comply with any future increases in the recycling quota within the stipulated time limits. For further information, please call 00800 1 777 7777.

Please note: changes may have been made to the product since this brochure went to press (04.09.2009). The manufacturer reserves the right to make changes to the design, form, colour and specification during the delivery period, provided these changes, while taking into account the interests of the vendor, can be deemed reasonable with respect to the purchaser. Where the vendor or the manufacturer uses symbols or numbers to describe an order or the subject of an order, no rights may be derived solely from these. The illustrations may show accessories and items of optional equipment which are not part of standard specification. Colours may differ slightly from those shown, owing to the limitations of the printing process. This brochure has been compiled by Daimler AG of Germany and is distributed internationally. It provides a general indication of the range of models, features, optional extras, colours and/or services available in various countries. Some of the models, features, optional extras, colours and/or services may not be available in your country, or may only be available in a different specification. Additionally some models, features, optional extras, colours and/or services may only be available in combination with others. For current and more specific information in relation to the range of models, features, optional extras, colours and/or services available in your country, and their pricing, you should contact your nearest authorised Mercedes-Benz Passenger Car Dealer. www.mercedes-benz.com