



S-Class

Mercedes-Benz



mark will also apply to mobility in future. Each route has its own character. Slowly. The thing that matters most, however, is how they are negotiated. Steady. The outside include assistance systems to provide the necessary serenity. By taking a walking machine. The dawn of the modern age saw these upright humans turning into fields of light-blue flax in full bloom. Even the most intelligent of cars should have single horsepower. As it has assistance systems which help you to observe the world as part of the thinking process, it is about more than this: being touched. You'd think we hear nothing? **Icons of mobility.** Ourselves, our natural frequency, the blue sky. Place your hands on the steering wheel. And feel the road and the lightness.

Mercedes-Benz

From road to memory

Our cars have epitomised luxurious mobility since the beginning of the 20th century. And they have thrilled generations of motorists who have style and great expectations.

The direct genealogy of the S-Class began in 1951 when the 6-cylinder Mercedes-Benz 220 model appeared at the first International Motor Show in Frankfurt. Even this very first model boasted a high standard of equipment and delivered effortlessly superior performance. Launched in 1972, the W 116 was the first S-Class, as it became known, and the official Mercedes-Benz representative in the luxury segment.

Outstanding comfort, innovative technology and comprehensive safety have been characteristic traits of the luxury saloon ever since. Crumple zones, ABS, airbags and ESP® – they are all trailblazing innovations in the history of automotive development. And they all began life in the S-Class. Before finding their way into many other models and vehicle categories and, therefore, into people's minds and the history books.

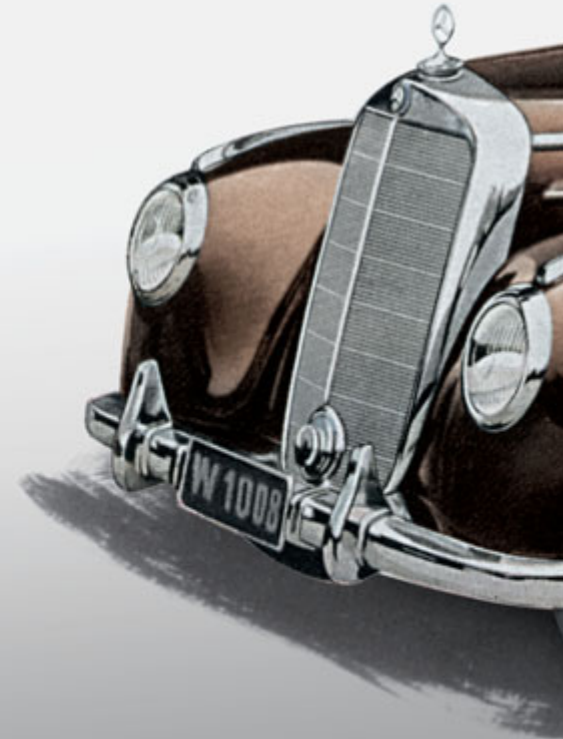





Inspiration

The S-Class is the benchmark for future mobility. Just as it has been for generations. Featuring innovations aimed at enhancing comfort, safety and environmental compatibility, it has become a role model and a showcase car for the entire automotive industry. The ninth generation likewise lives up to this billing: it includes the world's first standard-production hybrid vehicle with a lithium-ion battery as well as fuel consumption- and emission-reducing measures across the whole range, to name but two reasons. Furthermore, numerous sensors and intelligent electronic systems set milestones in terms of occupant protection, driving assistance and entertainment. Last but by no means least, its sophisticated, succinct appearance underlines its role on the road with effortless superiority. Like its forebears, the latest S-Class leaves no doubt: when it comes to mobility, it is the one true icon.

At a glance | From page 6, Insight | From page 28

S-Class



Facts

Comfort-oriented driving pleasure: S 400 HYBRID, diesel and petrol engines, transmissions, chassis and suspension.

Drive system & chassis | From page 36

Maximum safety: the latest active- and passive-safety technologies.

Safety | From page 48

Experience the essence of relaxed driving: light, multimedia and assistance systems, climate control, and seats.

Comfort | From page 52

The right S-Class for every situation: long-wheelbase version, S 600, S-Guard and S 600 Pullman Guard.

Model variants | From page 62

Powerful AMG saloons: the S 63 AMG and S 65 AMG models.

AMG | From page 70

S-Class individuality: standard equipment and optional extras, wheels, genuine accessories, paintwork, upholstery and trim parts, and designo.

Equipment | From page 74

To be precise: technical data and dimensions.

Facts & figures | From page 94

Star service: everything you need to know about Mercedes-Benz Centres and sales & service outlets, the MercedesCard, Mercedes-Benz mobility, Mercedes-Benz Bank, and test drives.

Services | From page 97



Power | The product of class and acceleration

It's truly inspiring to see someone achieve so much with so little effort. The same benchmark will also apply to mobility in future. Reducing fuel consumption and CO₂ emissions for the S-Class and developing an intelligent hybrid engine is anything but idealism - it is progress.

→ Page 38



Grace | Making light of every road

Each route has its own character. Sometimes they are generous, inviting, representative. Sometimes they are twisting, lonely and narrow. The thing that matters most, however, is how they are negotiated. The best approach: choose a car that lets you stay – and look – relaxed and in control.





Meditation | Concentrated relaxation

Steady breathing, a calm pulse and clear thoughts are inner signs of composure. Vital signs on the outside include assistance systems to provide the necessary serenity. By taking away much of the risk. Just as nearly a hundred sensors and numerous electronic systems in the S-Class do for you whilst you are driving. → Page 48









A close-up photograph of a car's interior door panel. The panel is finished with light-colored leather and features a horizontal wood-grain trim strip. A silver speaker grille is visible on the left side, and a circular speaker is integrated into the leather panel. The background shows the car's dashboard and steering wheel, which are partially obscured by a soft, white, ethereal glow.

Seats | The most comfortable way to travel

As humans learned to walk on two legs, the body evolved into the perfect walking machine. The dawn of the modern age saw these upright humans turn into sedentary creatures, which means that it is all the more important to make this seated posture as natural as possible. With features such as ergonomic, active seats. → Page 60





Touring | The world's your oyster

The old saying about a trip into the blue could have its origins in billowing fields of light-blue flax in full bloom. When the phrase was born, people were still chauffeured by a single horsepower. To be this relaxed – albeit more brisk – on the road today, there is the S-Class. It sets new safety standards. Thanks to assistance systems which help you to observe the surroundings and notice that which would normally go unnoticed. → Page 56









Emotions | One of the best ingredients of all

“I feel, therefore I am...” In times such as these, in which even vehicles are part of the thinking process, it is about more than this: you also have to be touched. As by the shape, structure and strong looks of the S-Class. Even the most intelligent of cars should always speak initially to the heart.







Etiquette | An instinctive feeling for the road

You'd think that power was the most important thing when moving heavy loads. Then you place your hands on the steering wheel. And feel the road and the lightness with which the several hundred kilowatts engulf you. Then you realise: the S-Class is driven by culture more than anything else.

→ Page 40, 42





Calm | The whisper of the tarmac

What do we hear when we hear nothing? Ourselves, our natural frequency, the blood in our veins? There is no better place than the S-Class to experience this.



Road

TV and driving don't normally mix. Or do they? A cinema screen on one side and a navigation display on the other? A single monitor on which two people can watch two completely different things at the same time even though they are sat side by side? Sounds like a dream of the future. But it is here now. And it is called SPLITVIEW. An innovative technology used in the S-Class. Bringing a whole new dimension to on-screen presentation.

Movie

SPLITVIEW allows the driver and front passenger to watch two feeds from different media at the same time – with a full screen diagonal – as if each had their own monitor. So the driver can view the route recommended by the navigation system, while the front passenger can lose themselves in the infinite beyond of a George Lucas movie, for example.



Those who dare

Less

What do you get when the energy of millions of ions, rather than inert metal, is used as a power source? An extremely ecofriendly drive system.

We speak from experience, since Mercedes-Benz is the world's first manufacturer to install a lithium-ion battery in a standard-production car - the S 400 HYBRID. Dispensing with conventional technology in this way benefits both the S-Class and its drivers: the innovative battery is much smaller than before, meaning that even the hybrid variant boasts the impressive boot capacity for which the S-Class is renowned. What's more, the energy density

win

means more

in the lithium-ion batteries is higher than in conventional nickel-cadmium batteries, for example. So the battery condenses greater power reserves within a small space yet weighs less, all of which has a positive effect on fuel consumption. And lower fuel consumption means lower emissions – another benefit for the environment.

If all this seems a little too rational, we are pleased to announce that, thanks to its intelligent drive system, the S 400 HYBRID with lithium-ion battery is not only sensible but also extremely powerful and dynamic.





/number of cylinders V6 7G-TRONIC for V6 engines and V8 engines Night V
173/3600 Active Body Control including crosswind stabilisation S 63 AMG Co
-wheel drive Acceleration 0-100 km/h (s) (long-wheelbase version) 5.4 (5.4)
-) PRE-SAFE[®] system S 400 HYBRID Tyre size front/rear 235/55 R 17 Reve
nk capacity (l)/incl. reserve approx. 90/11 Light-alloy wheels SPLITVIEW B
e version) 1955 (2005) Perm. GVW (kg) 2550 (2585) Total displacement (cc
W at rpm) 235/3600 Compression ratio 17.0 Rated torque (Nm at rpm) 730/
ed approx. (km/h) **The facts.** Speed Limit Assist Tyre size (long-wheelbase ve
g/km) (long-wheelbase version) 186-189 (188-191) Adaptive Highbeam Ass

36	BlueEFFICIENCY	48	Safe driving ATTENTION ASSIST Adaptive Highbeam Assist Night View Assist Plus Driving Assistance package	52	Light Headlamps Tail lights LED Light package Ambient lighting	62	Long-wheelbase version
37	Environment and efficiency					64	S 600
38	S 400 HYBRID					66	S-Guard
40	Diesel engines 6-cylinder 8-cylinder	50	In the event of danger or an accident Airbags PRE-SAFE® system PRE-SAFE® Brake NECK-PRO head restraints	54	Multimedia systems COMAND APS SPLITVIEW Rear Seat Entertainment package	68	S 600 Pullman Guard
42	Petrol engines 6-cylinder 8-cylinder 12-cylinder			56	Assistance systems Parking package Speed Limit Assist		
44	Transmissions 7G-TRONIC 5-speed automatic transmission			58	Climate control		
46	Chassis and suspension AIRMATIC Active Body Control (ABC) 4MATIC all-wheel drive			60	Seats Front Seat Comfort package Rear Seat Comfort package Rear Memory package		

S-Class in detail

70 **S 63 AMG**

72 **S 65 AMG**

74 **Standard equipment**

76 **Optional extras**

78 **AMG Sports package**

80 **designo**

Individualisation options
designo Selection

84 **Paintwork, upholstery and trim
parts**

90 **Wheels**

92 **Genuine accessories**

94 **Technical data**

96 **Dimensions**

97 **Services**

Experience Mercedes-Benz
at first hand
Mercedes-Benz Museum
MercedesCard
Mercedes-Benz mobility
Mercedes-Benz Bank
Test drive
Interactive Owner's Manual
Mobile internet

BlueEFFICIENCY – innovations for efficient mobility

We do not pay lip service to protection of the environment. It's a matter close to our hearts.

We can already offer you 66 models that place far less of a burden on the environment. Our BlueEFFICIENCY concept comprises innovations for efficient mobility as well as optimised processes all the way along the value chain.

The BlueEFFICIENCY measures – the

Mercedes-Benz efficiency package. The

BlueEFFICIENCY measures are comprehensive vehicle optimisations which save fuel and, therefore, ease the burden on the environment. Each model combines the most efficient engine with optimal aerodynamic and energy-management measures. Such measures include intelligently controlled ancillaries, tyres with optimised rolling resistance, the ECO start/stop function and lightweight components. Fuel consumption and, therefore, CO₂ emissions are reduced by up to 23%.

BlueTEC – the clean diesel. BlueTEC combines optimised combustion with a modular emission-control system, all of which makes BlueTEC an exceptionally clean diesel technology. Not only does it remove up to 95% of the particulate from the exhaust gases, it also reduces nitrogen oxides by up to 90%. All that remains is water and harmless nitrogen.

HYBRID – the intelligent combination of petrol and electric drive. During braking, the electric motor supplies the battery with kinetic energy. This energy is available when needed. What's more, the ECU shuts off the petrol engine when the speed falls below 15 km/h. In this way, a HYBRID can reduce fuel consumption by up to 20%.

BlueTEC HYBRID – clean diesel combined with electric drive. BlueTEC HYBRID technology marries the benefits of HYBRID technology with those of BlueTEC technology: during braking, the kinetic energy is converted into electrical

energy, which can be re-used when required. At the same time, the BlueTEC technology cleans the exhaust gases and removes most of the pollutants.

Innovative drive systems that break new ground. Concept BlueZERO F-CELL, E-CELL and E-CELL PLUS. We have developed three drive concepts with an electric motor and a battery for storing energy as part of our close-to-production Concept BlueZERO: E-CELL, which only draws its energy from the battery; E-CELL PLUS with a battery and an internal combustion engine (Range Extender); and F-CELL with an additional fuel cell for generating power.

But that is not all: under the banner “Design for Environment”, we also look at a vehicle's entire lifecycle – from planning to recycling. In short, BlueEFFICIENCY is good news for both you and the environment. Further information about our comprehensive measures can be found at: www.mercedes-benz.com/blueefficiency

Environment and efficiency

A role model for innovation ever since its inception, the S-Class is now forging unique paths when it comes to sustainability and environmental protection: with enhanced efficiency and the first hybrid vehicle to feature lithium-ion technology

The S-Class features clean and economical engines as well as sustainable technology – and not just under the bonnet. Aerodynamic measures, tyres with optimised rolling resistance and an intelligent energy-management system

help to reduce fuel consumption and CO₂ emissions. Energy is used efficiently, saved wherever possible and – as in the case of the S 400 HYBRID – stored and fed back into the system at another point. The S 350 CDI BlueEFFICIENCY model

boasts an LCA that has been improved by 10%, while the S 400 HYBRID achieves emission figures that easily undercut the levels specified by the world's most stringent standards.



- 1 Specially designed tyres for optimised rolling resistance
- 2 EU5 certification for V6 and V8 petrol engines
- 3 S 400 HYBRID with V6 petrol engine and electric motor as well as recuperative braking system (for recuperating braking energy) and ECO start/stop function
- 4 Aerodynamic exterior-mirror casings
- 5 Power steering pump with energy-saving control
- 6 Car always starts with transmission in "C" mode (Comfort)
- 7 Sealed joints on the headlamps for improved aerodynamics
- 8 Standstill decoupling means less strain is placed on the engine in the S 350 CDI BlueEFFICIENCY model

The measures vary depending on model and market

S 400 HYBRID

Ecofriendly motoring with a powerful hybrid drive system comprising a 6-cylinder petrol engine backed by an electric motor

The S 400 HYBRID¹ is driven by a powerful 6-cylinder petrol engine backed by a high-torque electric motor. In addition, optimised aerodynamics, recuperation of braking energy, the



Energy flow display in the S 400 HYBRID model

ECO start/stop function and low rolling-resistance tyres make it the most efficient car in the luxury class. And it offers the familiar high level of ride comfort, the full boot capacity, a luxurious interior atmosphere and even greater agility. This is ensured by the boost function, which briefly concentrates the power of both drive units.

At the heart of the S 400 HYBRID is an extremely light and small hybrid module with a peak torque of 160 Nm, which supports the 6-cylinder petrol engine. Optimum linking of the internal combustion engine and the electric module is controlled by the power electronics. For the first time ever in a standard-production car, a specially

developed lithium-ion battery drives the hybrid module. This battery is supplied by the recuperative braking system during braking. The current flow of energy from the electric motor or internal combustion engine is shown on a hybrid display in the instrument cluster and on the COMAND display. At traffic lights, for example, the ECO start/stop function switches off the internal combustion engine in the S-Class. Stored electrical energy is then used to restart the car as normal.

¹ Not available as right-hand-drive version

- 1 The efficiency-optimised 6-cylinder petrol engine with a displacement of 3.5 litres
- 2 The hybrid module, in the shape of a compact electric motor, is located between the petrol engine and the automatic transmission
- 3 The powerful lithium-ion battery has a high power density yet its dimensions are compact and it is light in weight
- 4 The power electronics coordinate the intelligent and efficient work performed by the petrol engine and electric drive system
- 5 The 7G-TRONIC automatic transmission ensures imperceptible switching between the power sources and acceleration without interruption of tractive power
- 6 Recuperative braking system: during braking, the electric motor becomes a generator and produces electrical current for the lithium-ion battery
- 7 Low rolling-resistance tyres for comfortable and economical motoring
- 8 The energy flow and drive system battery charge level are indicated constantly on the hybrid display

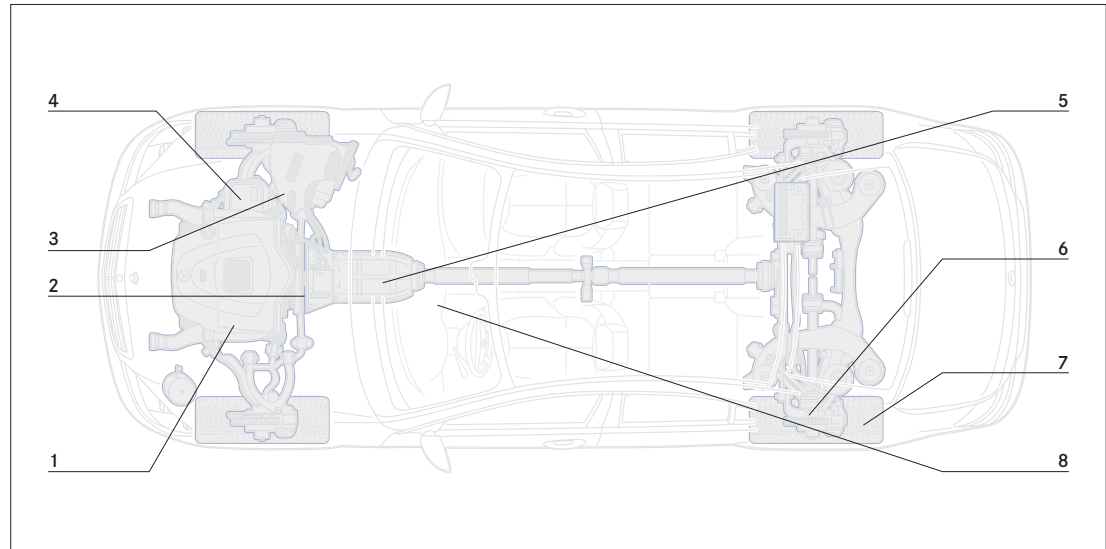

The hybrid components of the S 400 HYBRID in detail

Diesel engines

Consumption-optimised diesel engines for the S-Class: powerful, refined and efficient

6-cylinder diesel engine. A six-cylinder powerplant characterised by lightweight design throughout and featuring common-rail technology de-

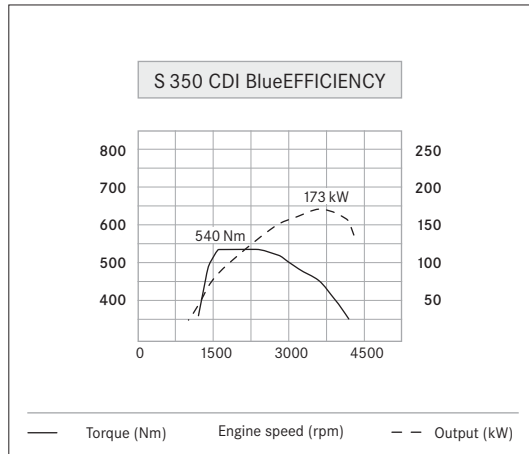

Peak torque: 540 Nm at 1600–2400 rpm

velops 173 kW in the S 350 CDI BlueEFFICIENCY model. The peak torque of 540 Nm is available from an engine speed of just 1600 rpm. What's more, the engine is clean and efficient. Thanks to an injection pressure increased to up to 2000 bar as well as optimised combustion chambers and extremely precise piezo injectors, CO₂ emissions have been reduced to 199 g/km¹. Fuel consumption has likewise been cut – to 7.6 litres¹ per 100 kilometres – as a result of specific detailed measures such as electrohydraulic power steering with a power steering pump that operates on demand, tyres with optimised rolling resistance and aerodynamic measures, for example on the exterior mirrors.

8-cylinder diesel engine. This powerplant impresses on several levels, not least on account of its performance figures: a peak torque of 730 Nm and an output of 235 kW at just 3600 rpm. Optimised flow conditions in the cylinder head intake ports, combined with a new turbocharger, ensure enhanced running and exceptional refinement.

Both diesel models feature a particulate filter as standard, significantly reducing particulate emissions.

¹ Overall figure for short-wheelbase model with standard tyres



The 6-cylinder diesel engine provides exceptional torque in every driving situation

Petrol engines

The consumption-optimised petrol engines for the S-Class combine driving enjoyment with environmental compatibility. Innovative Mercedes-Benz engine technology increases output yet reduces fuel consumption and CO₂ emissions to such an extent that the 6- and 8-cylinder units meet the requirements of the stringent EU5 emission standard

6-cylinder petrol engine. Designed using lightweight materials, this powerplant features four valves per cylinder and adjustable camshafts.

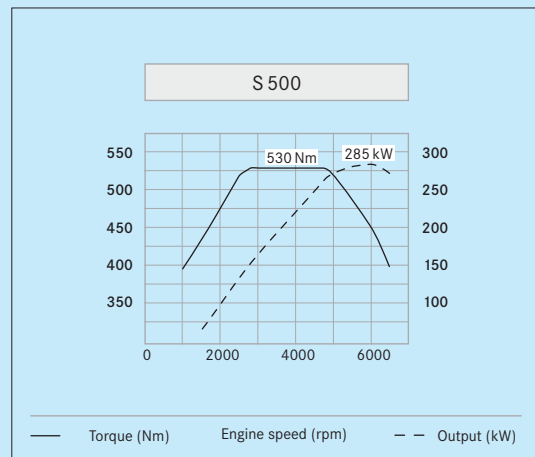

Minimum revs, maximum reserves

The result is high performance potential on the one hand and low weight on the other. In addition, the combustion processes within the 6-cylinder unit have been optimised to reduce both fuel consumption and emissions. The S 350 boasts a peak torque of 350 Nm and a rated output of 200 kW.

8-cylinder petrol engines. Effortless superiority and refinement are the major strengths of the V8 powerplants. Lightweight materials, such as magnesium as used in motor racing, optimised airflow and four valves per cylinder are the main reasons behind the high performance potential coupled with reduced fuel consumption and lower emissions. The S 450 develops 250 kW and provides a peak torque of 460 Nm, while the

S 500 achieves 285 kW and a maximum torque of 530 Nm.

12-cylinder petrol engine. The measure of all engines – offering outstanding refinement, spontaneous power delivery and sublime sound. Not only that, it is also highly efficient and technically innovative. The V12 biturbo engine achieves its peak torque of 830 Nm before even reaching the 2000-rpm mark. And it takes just 4.6 seconds to accelerate from 0 to 100 km/h. The twelve-cylinder unit's high output of 380 kW is largely down to the combination of two turbochargers and an intercooler as well as a V-angle of 60 degrees, all of which is key when it comes to achieving precisely the right power balance.



The 8-cylinder unit is refined and efficient

Transmissions

Whatever your driving style – economical or sporty – the S-Class transmissions have been optimised with your needs firmly in mind



The DIRECT SELECT lever on the steering wheel

7G-TRONIC. The V6 and V8 engines are paired with the Mercedes-Benz 7-speed automatic transmission as standard. The 7G-TRONIC is controlled using the DIRECT SELECT lever on the steering column. With its seven forward gears, the 7G-TRONIC ensures optimum revs every time, thus reducing fuel consumption. Short and smooth gear changes make for supreme ease of shifting and low noise levels. A set-up switch enables the driver to choose from three modes: Manual, Comfort or Sport. Manual gearshifts are performed using steering-wheel gearshift paddles – similar to those used in Formula 1.

5-speed automatic transmission. This transmission is the perfect complement to the twelve-cylinder engine's characteristics. Gear changes are so fast and smooth that they are barely perceptible, while just the right amount of power is delivered for every situation. A manual gearshift option is available if required.

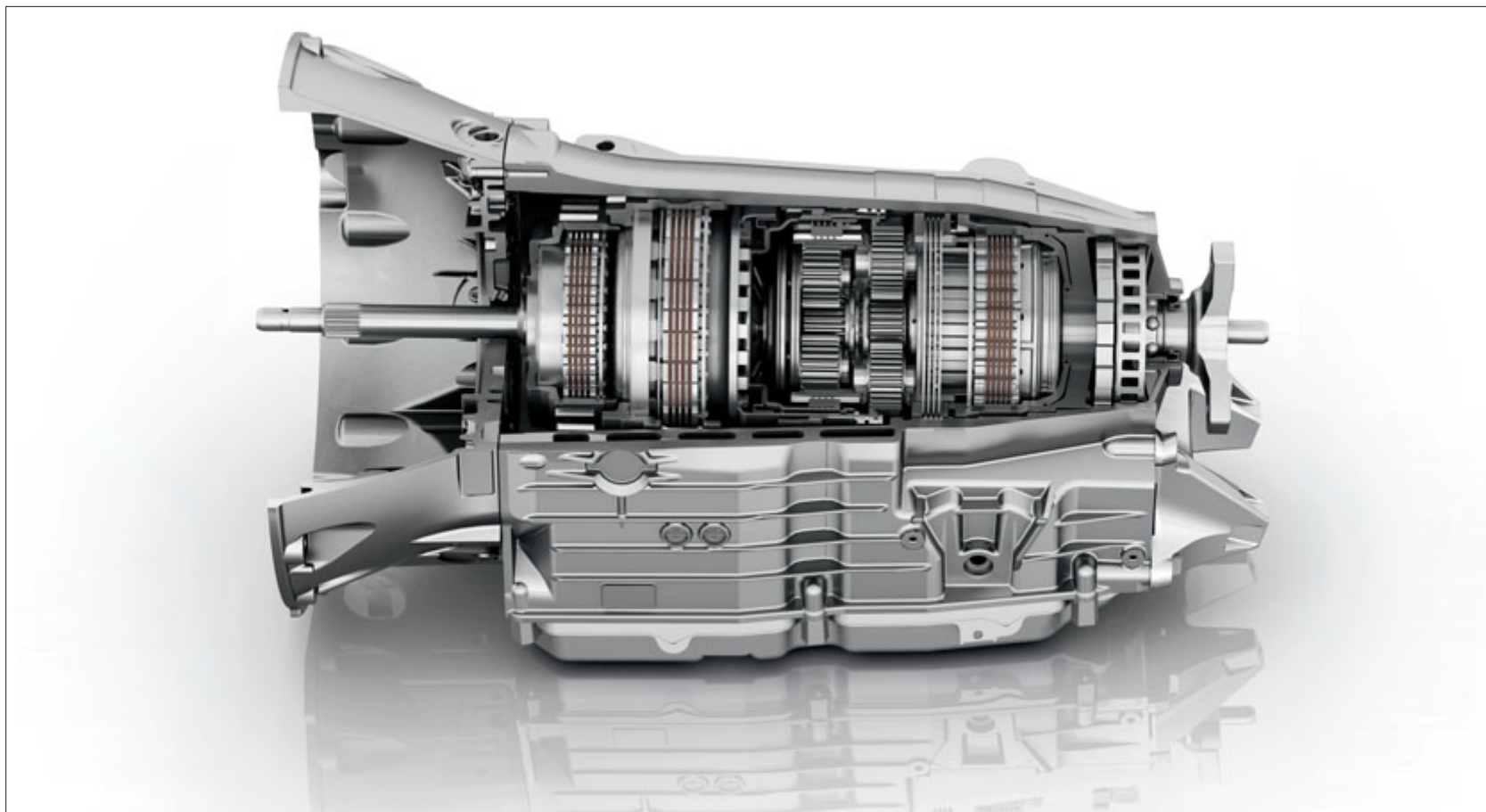

The 7G-TRONIC: the result of more than 40 years of experience in transmission development

Chassis and suspension

Comfort is omnipresent – thanks to precision-tuned chassis and suspension components as well as powerful all-wheel drive

The AIRMATIC air suspension, fitted as standard, and Active Body Control (ABC) with crosswind stabilisation make for high levels of comfort and agility as they adjust the chassis and suspension settings to suit the current situation with a minimum of fuss. Sporty suspension settings are selected for dynamic driving, while a more comfort-oriented stance is adopted for leisurely cruising.

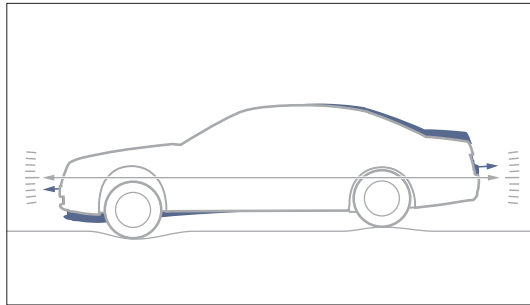

AIRMATIC combines effortlessly superior roadholding with a high degree of comfort

ABC uses microprocessor-controlled suspension struts to compensate for the car body's lift, pitch and roll: it counteracts these movements by selectively raising or lowering the chassis. The same process is employed to reduce body movements when the S-Class moves off or is braked. Hence ABC ensures optimum roadholding, agility, dynamism and an effortlessly superior

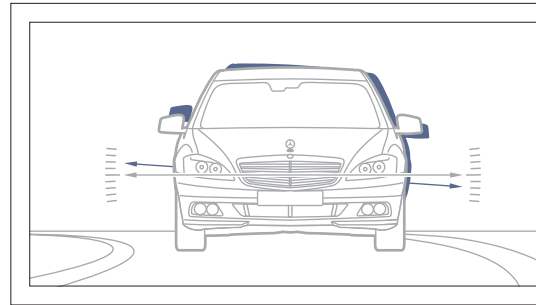

ABC ensures an extremely agile and dynamic driving feel, while crosswind stabilisation improves handling by actively influencing the wheel forces

rior driving feel in every situation. Crosswind stabilisation, meanwhile, can compensate for the effect of crosswinds, by distributing the wheel load, and helps to maintain directional stability, even in stormy weather. ABC with crosswind stabilisation is fitted as standard for the S 600 and AMG models or as an optional extra for the V8 models with rear-wheel drive.

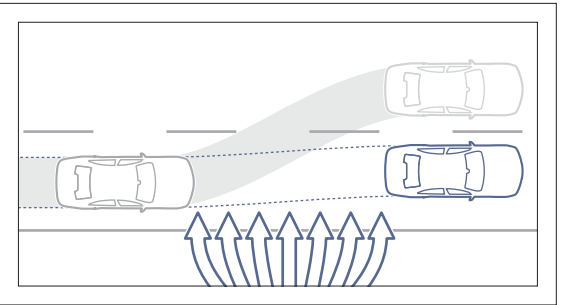

4MATIC. The permanent all-wheel-drive system distributes the engine power to both axles at a fixed ratio of 45 % to 55 % – equalling 100 % traction. To this end, 4MATIC uses the Electronic Stability Program (ESP®) and the Electronic Traction System (4ETS). The latter enables controlled braking of spinning wheels and, as a consequence, increases the drive torque at the wheels

offering good traction, allowing plenty of power to be planted on the road when moving off and when accelerating, especially on poor road surfaces. Automatic braking pulses make it easier to move off on slippery surfaces as well as enhancing stability during critical manoeuvres. A further advantage of the system is the fact that it is hardly any heavier than the rear-wheel-

drive version on account of the compact design, intelligent choice of materials and high level of efficiency. 4MATIC is only available in conjunction with the 7G-TRONIC automatic transmission, meaning that it is not an option for the twelve-cylinder and AMG models.

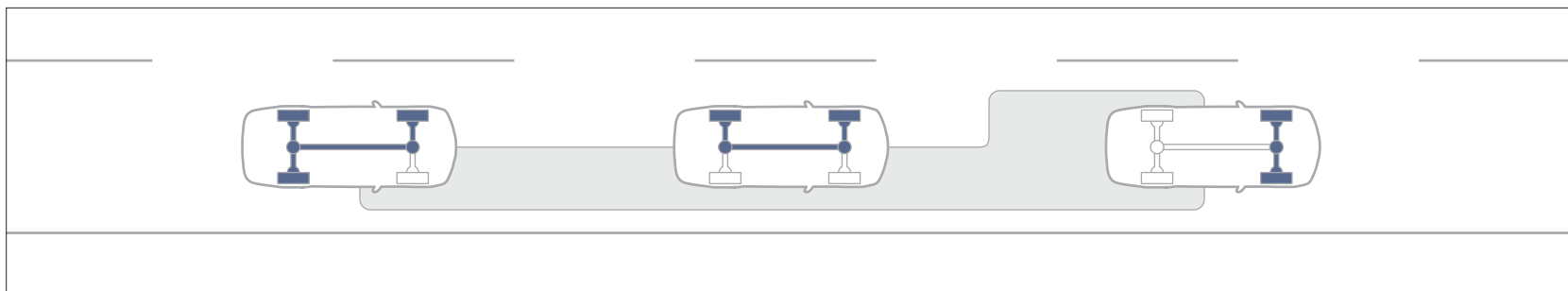

The electronic traction system 4ETS automatically sends the drive torque to the wheels offering sufficient grip

Safe driving

Assistance systems help to detect and defuse critical situations and, therefore, prevent accidents wherever possible

ATTENTION ASSIST (standard)¹. This new drowsiness detection system is useful on long trips. At speeds of between 80 and 180 km/h, ATTENTION ASSIST can warn the driver as soon as it detects signs of inattention. To this end, several sensors analyse driving behaviour on a permanent basis and detect typical signs of drowsiness, such as involuntary steering movements.



If ATTENTION ASSIST detects signs of drowsiness, it recommends that the driver take a break

¹ Not available for S 400 HYBRID

Adaptive Highbeam Assist (option in LED Light package). Even at night, Adaptive Headlamp Assist allows excellent visibility without dazzling oncoming traffic or vehicles in front. It increases or reduces the headlamp beam smoothly and automatically – manual intervention is not required. The transition from high to low beam is almost seamless, so the driver does not perceive any abrupt change in the degree of illumination.

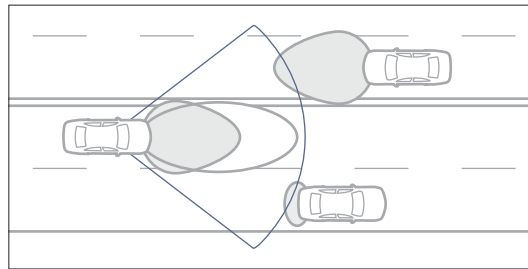

Adaptive Highbeam Assist ensures an almost seamless transition between low and high beam

Night View Assist Plus (option). The infrared camera at the heart of this system highlights the entire area normally covered by high beam – in the form of a black-and-white image displayed in the instrument cluster. Furthermore, any persons detected are also highlighted, making it easier for drivers to get their bearings at dusk and dawn or in darkness, and enabling them to react more quickly in dangerous situations.

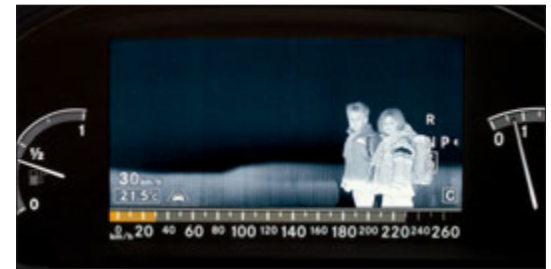

Night View Assist Plus makes it easier to see other people

Driving Assistance package (optional). The Lane Keeping Assist system operates using a camera that can detect lane markings. If the car leaves its lane unintentionally, the system warns the driver by making the steering wheel vibrate gently. Lane Keeping Assist is so intelligent that it can even detect when lane markings are crossed intentionally – in which case no warning is issued.

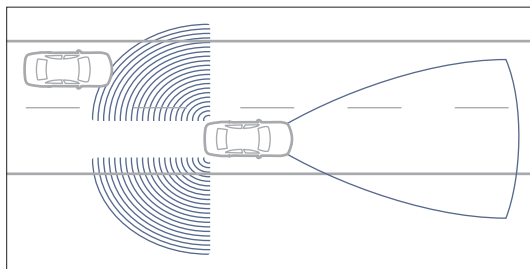

Lane Keeping Assist and Blind Spot Assist can warn the driver in potentially dangerous situations

Blind Spot Assist provides an increased level of safety when changing lanes. Two radar sensors monitor the area that the driver cannot see in the exterior mirrors – the blind spot. If the system detects another vehicle in the danger zone, a red warning triangle illuminates in the exterior mirror. If the driver still indicates to change lanes, an additional warning tone sounds.



Blind Spot Assist enhances safety when changing lanes

DISTRONIC PLUS proximity control uses radar to help the driver maintain a preset distance between the car and the vehicle in front, making the driver's job easier in both moving and stop-and-go traffic. Finally, the PRE-SAFE® Brake can brake the car automatically ahead of an imminent head-to-tail collision.

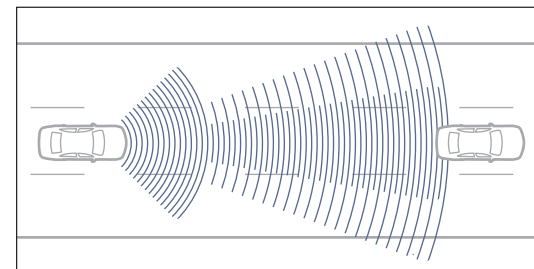

DISTRONIC PLUS proximity control maintains a set distance between the car and the vehicle in front

In the event of danger or an accident

Sometimes accidents are unavoidable: for this eventuality, numerous systems have been developed for the S-Class to ensure even greater occupant protection



A total of nine airbags can protect you and other passengers in the event of an accident

Airbags (standard). A pioneer of automotive safety, the S-Class was first equipped with a driver airbag way back in 1981. A front-passenger airbag was added from 1985 onwards, offering even more effective occupant protection. Nowadays the luxury saloon is equipped with nine sophisticated airbags, which help to prevent injuries in the event of a collision. Standard equipment includes two-stage front airbags, sidebags in the seat backrests for the driver and the front passenger as well as windowbags. What's more, the driver can count on an integrated kneebag, which offers additional safety potential in certain situations as it protects the legs and, in particular, the knees in the event of an accident. Rear sidebags are also included as standard, to protect the rear-seat occupants.

PRE-SAFE® system (standard). The anticipatory occupant protection system is able to detect certain critical driving situations in advance and activate preventive measures. If an imminent accident is detected, the system can close the side windows, move the front-passenger seat to a more favourable position and tension the

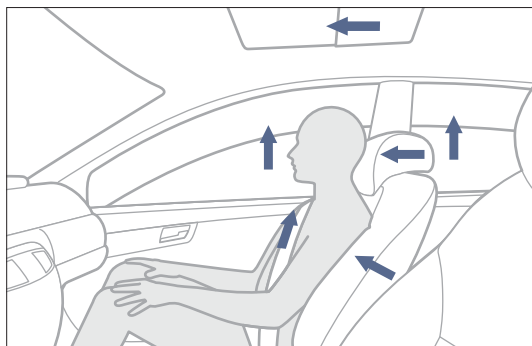

The PRE-SAFE® anticipatory occupant protection system helps to mitigate the consequences of accidents

seat belts automatically. It can also close the sliding sunroof and provide lateral support for the occupants if the multicontour seats are specified.

PRE-SAFE® Brake (option in Driving Assistance package). This system provides the driver with visual and audible warnings if there is a risk of

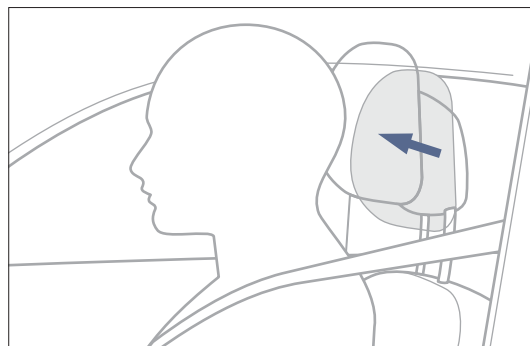

The NECK-PRO head restraints can reduce the risk of whiplash significantly in a rear impact

a collision. If the driver fails to respond, it initiates autonomous partial braking and triggers PRE-SAFE® measures. Autonomous emergency braking is performed subsequently if required. These measures can bring about a significant reduction in the impact speed and the accident severity.

NECK-PRO head restraints (standard). The head restraints for the driver and front passenger can be activated by sensor control in a rear impact: a spring mechanism moves the head restraints forwards and upwards, providing earlier support for the head and reducing the strain on the spine.

Light

Sophisticated LED technology enhances the already impressive looks of the S-Class, especially at night. Daytime driving lights are integrated in the front bumper

Headlamps (standard). The S-Class is equipped with bi-xenon headlamps. The distinctively shaped indicators make the car easier to see. Then there are the new daytime driving lights which, like the fog lamps, are round and integrated in the bumper.

Tail lights (standard). The extensive use of visible LEDs for the indicators, the tail lights and the brake lights gives the tail-light clusters a particularly distinctive look. The innovative LED design based on a classic S-Class look enhances visibility for the traffic behind.

LED Light package (option). The sophisticated technology at the heart of this package gives the S-Class face a highly distinctive look. The LED daytime driving lights – in the form of luminescent strips with chrome surrounds – are integrated on the right and left of the bumper. The indicators and sidelights are likewise based on LED technology.



Tail lights featuring sophisticated LED design

The package also includes the Intelligent Light System – with active light function, country mode, motorway mode, enhanced fog lamps and cornering light function – as well as Adaptive Highbeam Assist.



LED Light package: Intelligent Light System and LED daytime driving lights in the bumper

Ambient lighting (option). This light concept stylishly accentuates the interior design in the dark. As soon as the driver opens the door, they are met by a welcoming light which makes the interior appear even larger and even more comfortable. When the door is closed, the LED lights are dimmed automatically. For this, the light can be adjusted to one of five possible brightness settings using COMAND. Furthermore, the lighting mood can be varied by selecting one of three colours. Whether it be ice blue (polar), amber (solar) or white (neutral), it's all a matter of personal taste.



The ambient lighting lights up as a narrow band of LEDs along the wood trim strips, the dashboard and all four doors. These lights are dimmable and can be made to come on in one of three different colours

Multimedia systems

Available in addition to the standard-fit USB, Bluetooth® and SD card interfaces, SPLITVIEW, the Harman Kardon® Logic 7® surround sound system and the Rear Seat Entertainment package provide outstanding entertainment for every occupant

COMAND APS (option in Navigation package). The multimedia system combines telephone, audio, video and hard-disc navigation, showing the information on a central colour display. As well as playing video and audio DVDs, the integrated DVD player can also handle CDs and MP3 files. In addition, MUSIC REGISTER lets you store up to 2500 music tracks. Music Search allows you to

search this database based on track title or artist name, for example, so that you can always locate the music you want quickly and easily. The COMAND APS display shows maps – those used by the navigation system, for example – in 3-D.

SPLITVIEW (option in Front Seat Entertainment package). SPLITVIEW uses an innovative dis-

play technology to allow the driver and front passenger to each view a different picture on a single monitor. While the driver can view navigation information, for example, the front passenger can put together their own personal programme of entertainment. Sound is output via wireless headphones.



COMAND controller in the centre console



SPLITVIEW displays two different images at the same time – for the driver (1) and front passenger (2) – on a single screen

Rear Seat Entertainment package (option).

Entertainment for the rear passengers comes courtesy of the Rear Seat Entertainment package, consisting of a DVD player, two 8-inch TFT colour displays mounted on the head restraints of the front seats, two sets of wireless headphones, remote control and two Aux-in connections. It is therefore possible to watch films



8-inch rear screen mounted on the head restraint

or connect a games console whilst on the road.

Excellent, further optimised sound quality is provided by the Harman Kardon® Logic 7® surround sound system. It combines surround sound in Dolby Digital 5.1, a 13-channel DSP sound amplifier, 14 speakers optimised to suit the car interior and a subwoofer. The 3-D stereo sound ensures



The Harman Kardon® Logic 7® surround sound system: a first-class acoustic experience with an output of 600 watts

sheer listening pleasure whilst the speed-sensitive volume control provides a constant sound impression. What's more, the rear passengers can also control the in-vehicle players and interfaces.

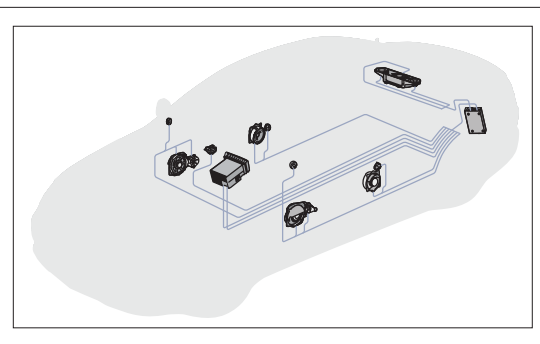

Assistance systems

Numerous assistance systems help to enhance ride comfort and make life even easier for the driver of the S-Class



All-round visibility when parking and reversing – thanks to the optionally available reversing camera

Parking package (option). The reversing camera provides assistance to make it easier and safer to park in reverse by affording the driver a better view of the area around the rear of the car. A wide-angle lens is installed below the boot handle. The reversing camera is activated automatically when reverse gear is engaged and films the area immediately behind the car, sending the image to the COMAND display.

The Parking package also features PARKTRONIC including Parking Guidance. The Parking Guidance system measures parking spaces automatically and helps the driver to find a parking space and to park in it. The data recorded by ultrasonic sensors are used to determine whether a parking space is large enough. The parking situation

is then shown on the multifunction display. Yellow markings on the display indicate the path that needs to be steered, red markings the path that is currently being steered. When the two overlap, they turn green. The PARKTRONIC display also indicates the current distance to obstacles.

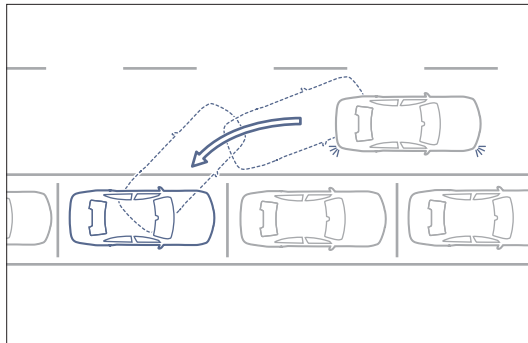

Parking Guidance provides parking instructions

Speed Limit Assist (option in Navigation package). This system detects speed-limit signs on the road and indicates the detected speed limit to the driver on the display. It therefore enhances both safety and convenience. This enhanced convenience is of particular benefit

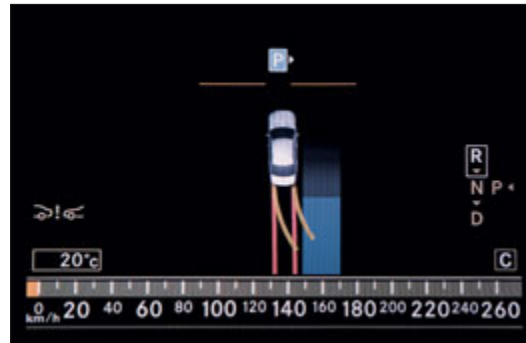

Parking Guidance is easy to use

on routes with variable speed limits or road works.



Speed Limit Assist display in the instrument cluster

Climate control

An ideal interior climate enhances comfort and increases stress-relieving safety in the S-Class. The standard specification includes four front climate zones, with two rear climate zones available as an option

The automatic climate control system allows the driver and front passenger to adapt the climate in their respective seats to suit their individual



Ideal temperature for each individual occupant at the push of a button

requirements – independently of each other. It keeps the temperature at the desired level automatically, even in strong sunlight. To this end,



The optional rear air conditioning

sensors record the temperature inside and outside the S-Class, controlling the heating, cooling and fan for each temperature zone individually, according to requirements. Even the airflow can be adjusted in line with individual needs, with a choice of three modes: “Diffuse”, “Medium” or “Focus”.

The front footwell temperature can be adjusted in line with the interior temperature separately (precisely as required, two levels warmer or colder). An activated charcoal filter ensures that only clean air enters the car.

Separate rear air conditioning is available as an option for the two rear zones. A control unit on the rear face of the centre console allows the rear

passengers to set their preferred climate individually. As well as offering an automatic mode, the unit features manual controls with which the air temperature and distribution can be set separately for the left and right sides.

So there is always an ideal climate inside the S-Class – in every seat – enhancing comfort on the one hand and allowing the driver to concentrate better on the other. For the safety of all the occupants.

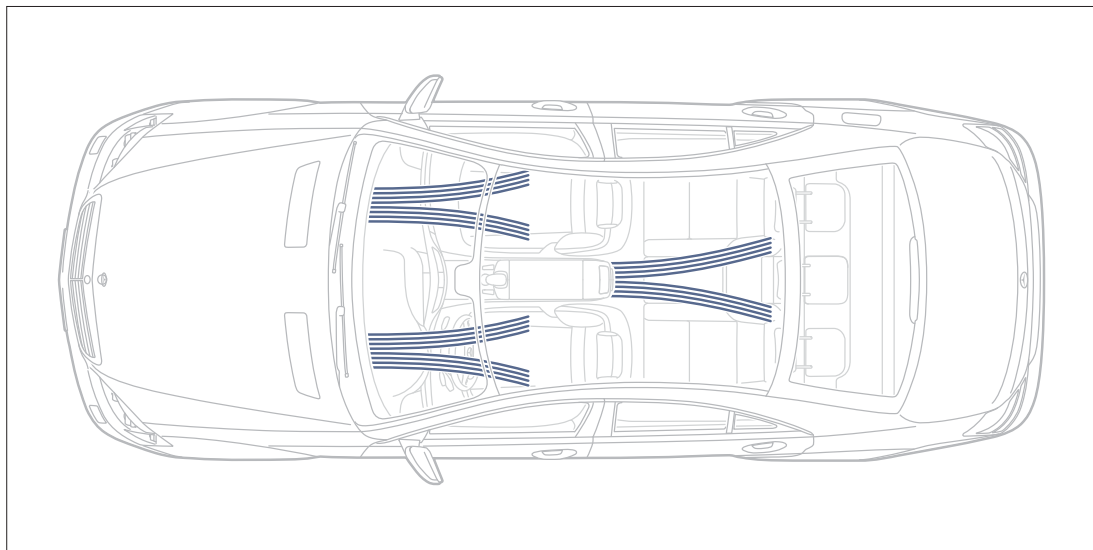

The independently controllable temperature zones in the S-Class

Seats

The seats in the S-Class meet the very latest requirements in terms of ergonomic design, comfort and safety

Front Seat Comfort package (option). The active multicontour seats with massage and dynamic handling function as well as NECK-PRO luxury head restraints offer the driver and front passenger an exceptional degree of comfort, even on longer trips. A series of air chambers for the lumbar and shoulder areas can be optimised to suit individual body shapes, while the seat's side bolsters adjust automatically and dynamically in line with the car's movements, ensuring optimum and reliable support at all times – especially when cornering.

Well-being is enhanced by seven massage chambers and four massage programs which use rolling movements to stimulate the back muscles and thus play an active part in helping the occupants to maintain physical fitness.



The active multicontour front seats with massage and dynamic handling function



Multicontour rear seats with massage function

Rear Seat Comfort package (option). Multicontour seats with a massage function and luxury head restraints are available for the rear compartment. They can be adjusted to suit your own particular body shape. The massage function ensures an exceptionally pleasant trip, particularly on longer routes.

Rear Seat Memory package (option). Both outer seats in the rear come with the option of power adjustment and a Memory function, allowing you to save your preferred seat settings and call them up again at the touch of a button. What's more, the individual rear seats feature the PRE-SAFE® positioning function.

Long-wheelbase version

Every amenity for travel, relaxation and work



The long-wheelbase version of the S-Class

Measuring 13 centimetres longer than the standard model, the long-wheelbase S-Class more than lives up to its name, offering the rear occupants even more legroom. The list of standard equipment and appointments is equally long and includes leather appointments, heated front and rear seats, power adjustable outer rear seats, a sliding sunroof, and a blind which can cover the entire rear windscreen.

Optional extras include individual rear seats and the panoramic sliding sunroof as well as manually adjustable folding tables that provide an ideal working environment in the rear.

The Rear Seat Entertainment Package is likewise available as an option, as is a second handset in the armrest. If the latter is specified, the rear

occupants as well as the front occupants can take calls.



Extra legroom for the rear passengers



An exclusive ambience for all passengers

S 600

Well thought-out details and a wealth of comfortable appointments in the S 600 make for supremely relaxed motoring

The S 600 is specified with luxurious Exclusive PASSION leather appointments ex factory. The active multicontour front seats, multicontour rear seats with massage function, door centre panels, centre console and dashboard are all trimmed in fine leather, while the A-, B- and C-pillars are finished in Alcantara® – as is the roof liner with



V12 logo appears in instrument cluster when S 600 is fired

its longitudinal fluting. The trim parts on the doors, dashboard, armrest and steering wheel are available in exclusive poplar wood. KEYLESS-GO and ambient lighting – which can be switched on in one of three colours – are also provided, of course, as is outstanding sound, courtesy of the Harman Kardon® Logic 7® surround sound system. The lat-



Exclusive V12 tailpipes with vertical partition

ter is part of the standard-specification Entertainment package in the front. Then there is the Navigation package with hard-disc navigation system that forms part of COMAND APS, not to mention PARKTRONIC incl. Parking Guidance and the reversing camera¹ to assist with parking.

The front section of the S 600 is dominated by the radiator grille in chrome with three double louvres. Another visual highlight is the standard-fit LED Light package, which includes the Intelligent Light System, Adaptive Highbeam Assist and LED daytime driving lights.

Even when it is not moving, the Saloon with 18-inch light-alloy wheels featuring V12 styling positively exudes dynamism. Characteristic traits include the V12 labels on the wings, the tailpipes integrated in the bumper with vertical partition and a chrome trim strip on the rear bumper.

¹ Optionally available. Standard equipment from 01.02.2010



The front section with radiator grille and standard-fit LED front lights

S-Guard

Only a protection system fitted ex factory offers what really matters in reality: comprehensive special protection → www.mercedes-benz.com/guard

Perfectly concealed beneath an outer skin that looks identical to that of the standard-production model lies an integral network of protective components. The passenger cell is a brand-new design from the bottom up and incorporates highly effective reinforcements. Especially at points that are no longer accessible once the body is complete. The result, produced in a strictly screened production facility, is a protective area consisting of high-strength steel, aramid and

special glass. Like every Mercedes-Benz, the S-Guard needs to pass all the key quality and safety tests with flying colours, of course, not to mention specific special-protection tests involving firearms and explosives. Only then can it be called an S-Guard – certified by independent authorities and forearmed for extreme situations.

An S-Guard includes all the familiar S-Class amenities, of course.

Plus all the usual safety components – such as the electronic control systems, brakes, chassis and suspension – which have been adapted to take into account additional requirements due to the extra weight of the S-Guard. The S-Guard lives up to its claim of being able to offer mobile special protection and exclusive comfort at the highest level.

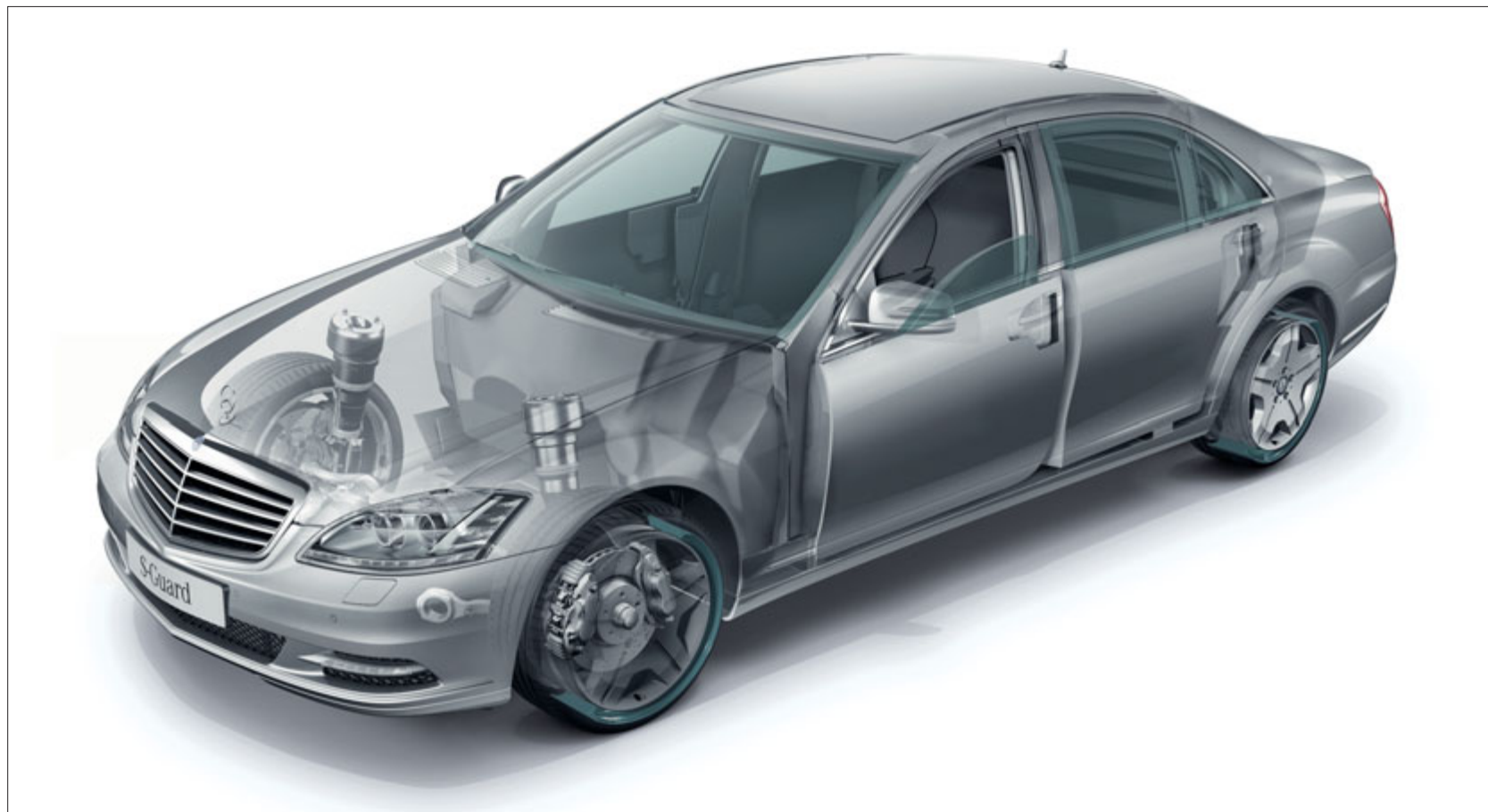

Mobile protection of the highest calibre: the S-Guard offers a degree of safety and quality not achievable by simply retrofitting armoured plating

S 600 Pullman Guard

A prestigious combination of special luxury and special protection

Pullman saloons combine all the attributes of a state limousine ex factory. They have been inextricably linked with major events and prominent personalities for some eight decades.

Like the S-Guard, the S 600 Pullman Guard is based on the “factory-integrated protection” principle. Every last detail has been perfectly conceived and designed, developed, tested and certified to make a Pullman the benchmark.

From the protection concept to the 115 cm longer wheelbase, absolutely everything is fitted “ex factory” and comes with the Mercedes-Benz brand’s quality promise. The inside of the Pullman invites you to discover a whole new



S 600 Pullman Guard – a state limousine offering the highest protection

dimension to space. Here you will find every amenity. From the integrated refrigerated compartment to state-of-the-art communication systems and exclusive rear seat entertainment. It can be a mobile office, a worthy and presti-

gious companion, a discreet meeting room, or a welcome retreat. The materials used for the appointments – selected wood, exclusive stone, fine leather and pristine paintwork – reflect the sheer exclusivity of the Pullman saloon. The

inner qualities are also mirrored on the outside, wherever you look. Size and generosity abound, ensuring a stately appearance and elegant comfort.



Comfortable space in an exceptionally generous format: one of the defining characteristics of the S 600 Pullman Guard



Exemplary safety, outstanding comfort, exclusive materials

S 63 AMG

A four-door sports car → www.mercedes-amg.com



Excitement and dynamism combined in a luxury saloon: the S 63 AMG

The exterior of the S 63 AMG positively exudes forwards thrust. A powerful-looking front apron with a classic AMG look incorporates the LED daytime driving lights, while the diffuser-style rear apron finished in the body colour catches the eye at the rear. The S 63 AMG features the



AMG sports seats upholstered in PASSION leather with an exclusive AMG seat pattern and natural leather in the side bolsters

AMG 6.3-litre V8 naturally aspirated engine developing 386 kW and a peak torque of 630 Nm.

There is also power in control – thanks to the AMG high-performance composite brakes and AMG sports suspension, which prevents body



AMG sports exhaust system with chromed twin tailpipes

movements and suppresses pitch and roll. Optional extras include 20-inch AMG twin-spoke forged wheels with a polished, titanium-grey finish.



20-inch AMG forged wheel

S 65 AMG

The most powerful AMG saloon of all time combines imposing power and exclusive dynamics → www.mercedes-amg.com



The S 65 AMG underlines its unique standing in the segment for exclusive V12 high-performance saloons

The most powerful S-Class model: the S 65 AMG with AMG 6.0-litre V12 biturbo engine develops 450 kW and achieves a peak torque of 1000 Nm. The result is exhilarating performance – acceleration from 0 to 100 km/h in just 4.4 seconds. Gears can be selected using the DIRECT SELECT

lever or aluminium gearshift paddles on the AMG sports steering wheel – as in Formula 1. The design is brought to a successful conclusion by an AMG sports exhaust system with two chromed twin tailpipes featuring AMG V12 styling, with 20-inch AMG forged wheels painted in titanium

grey providing a further dynamic touch. Optional extras include trim parts in black piano lacquer/carbon fibre from the AMG Performance Studio.

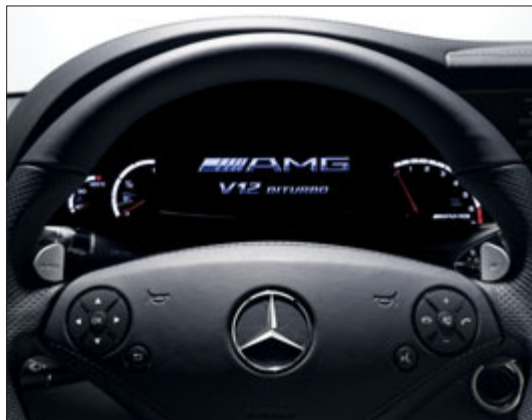

The AMG sports steering wheel and the AMG instrument cluster



AMG trim parts in black piano lacquer / carbon fibre



Exclusive interior appointments with AMG sports seats in Exclusive PASSION leather and AMG V12 diamond pattern

Standard equipment | Selection



Multifunction steering wheel in nappa leather



ATTENTION ASSIST



Chrome-effect electronic key



COMAND colour display



Bluetooth® function in COMAND



Automatic climate control



Telephone keypad



Centre console with COMAND Controller



SD card slot



Daytime driving lights and fog lamps with dual circular design



LED indicators in the exterior mirror



LED tail light

Optional extras | Selection



Wood/leather steering wheel



KEYLESS-GO



DISTRONIC PLUS



Reversing camera



Front Memory function



Harman Kardon® Logic 7® surround sound system



Rear screen



Active multicontour front seat setting

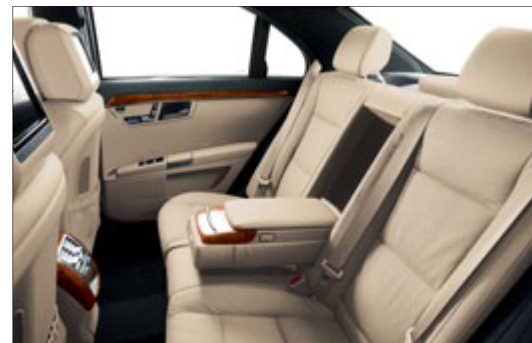

Multicontour rear seats



Refrigerated compartment in the rear armrest



Folding tables, manually adjustable



Panoramic sliding sunroof

Some of the illustrated features may show package items

AMG Sports package

Dynamic design and exclusive sportiness → www.mercedes-benz.com

The AMG Sports package injects the S-Class with even more dynamism. It begins on the outside with a powerful-looking AMG front apron and side



Black ash wood trim

skirts, continuing all the way back to the distinctive AMG rear apron. The impressive look is completed by 19-inch AMG 5-spoke light-alloy



The distinctive rear apron – part of the AMG Sports package

wheels with a high-shine finish or, as an optional extra, 20-inch AMG twin-spoke light-alloy wheels.

Further distinguishing features vis-à-vis the standard model include the painted brake callipers with “Mercedes-Benz” lettering and, for the 6-cylinder models, larger front brake discs. There are even more differences inside, including trim parts in black ash, which are exclusively available as part of the AMG Sports package. Then there is the wood/leather steering wheel and, finally, the sports pedals in brushed stainless steel and matching AMG floor mats.



The AMG Sports package lends the S-Class a sporty, dynamic aura

designo

A wealth of high-grade appointments and special details make designo an alluring proposition

The hand-crafted designo range is a source of almost unlimited inspiration with its wide choice of colours, exclusive trim parts and fine

materials. Even the exterior paintwork can be ordered in one of several additional colours.

Moving inside, there is a choice of designo aniline leather or designo natural leather in various colours. Plus customers can select from a wide



Door centre panel in designo light brown Exclusive aniline leather (X35)



Trim parts in designo natural maple grain (W64)

range of stylistically matched wood or stone trim parts, for example wafer-thin polished granite from Norway or high-gloss black piano lacquer, applied in up to ten coats.

Together with the characteristic seat pattern with ten-rib vertical fluting and the designo metal badge in the seat backrests, the wood/leather steering wheel and the roof liner in Alcantara® create an extra-special atmosphere.



Upholstery in designo light brown Exclusive aniline leather (X35) with trim parts in designo natural maple grain (W64)

designo Selection

Lending the long-wheelbase version of the S-Class an unmistakable character – the designo Selection

→ www.mercedes-benz.de/designoselection

High-quality designo appointments add a highly personalised touch to the S-Class. Here the designo Selection package can make your deci-

sion easier as it already includes all the exclusive features. With designo Selection, you can choose any of the available designo exterior paint finishes

(designo metallic, designo mystic or designo magno).



Upholstery in designo porcelain Exclusive aniline leather (X27) with trim parts in designo black piano lacquer (W69)



designo wood/leather steering wheel in black piano lacquer

You can also select any of the available colours for the seat upholstery in designo Exclusive aniline leather. And any of the available designo wood trim parts along with a matching designo wood/leather steering wheel. Then there is the roof liner in designo black nappa leather with longitudinal fluting as well as an exclusive designo logo in 18-carat solid gold. Whether your preference is for a harmonious colour scheme or a high-contrast combination, the designo Selection is sure to emphasise the exclusivity of your S-Class. To help you make your choice, you can check possible combinations online beforehand, entirely at your own leisure. Here you will find a specially designed help function to take you through the numerous options offered by the designo Selection.



designo logo in 18-carat gold



Upholstery in designo porcelain Exclusive aniline leather (X27)



Roof liner in designo black nappa leather with longitudinal-fluting design

Paint, upholstery and trim

The nano-particle coat puts the shining finish to the corrosion-prevention system. A clear coat mixed with ceramic particles is applied on the sheet metal. Once dried, it forms a dense molecular structure. This surface makes the nano-particle coat resistant to scratching, allows dirt to simply drip off, and ensures lasting shine and optimum value retention.

NON-METALLIC PAINT

040 black

METALLIC PAINTS

112 chromite black

197 obsidian black

300 periclase green

359 tanzanite blue

368 flint grey

544 carneol red

775 iridium silver

792 palladium silver

798 sanidine beige

SPECIAL METALLIC PAINTS

526 dolomite brown

799 diamond white BRIGHT

NON-METALLIC PAINT



040

METALLIC PAINTS

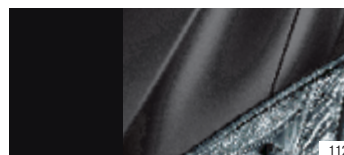

112

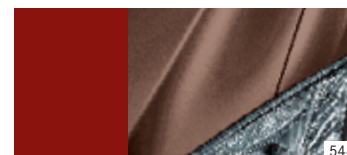

544

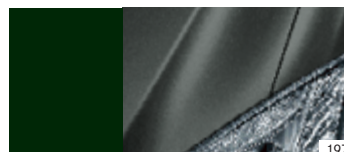

197

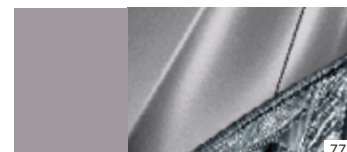

775

SPECIAL METALLIC PAINTS

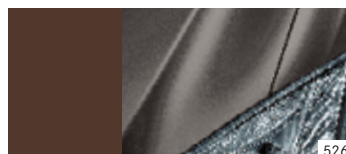

526



300



792

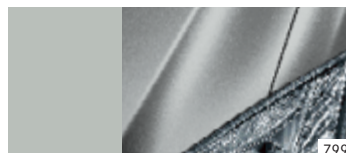

799



359

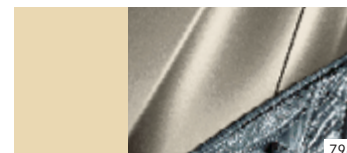

798

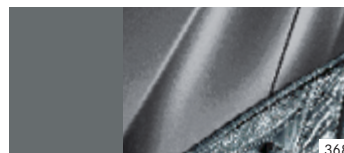

368



The black colour scheme comes with a choice of seat covers in fabric (standard) or, optionally, leather (standard for long-wheelbase version) or PASSION leather. In this case, the interior (dashboard, steering wheel, centre console, side panels and carpets) are all in black. The Exclusive PASSION leather variant is optionally available for the long-wheelbase version, in which case the dashboard, door linings, seatback panels, ruffled pockets and parcel shelf are additionally trimmed in PASSION leather. A further elegant touch is provided by the roof liner and the A-, B- and C-pillars in Alcantara®.

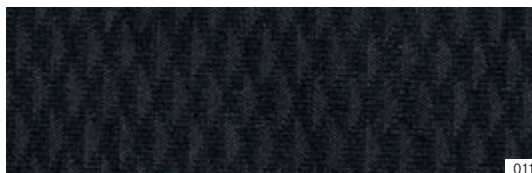

011

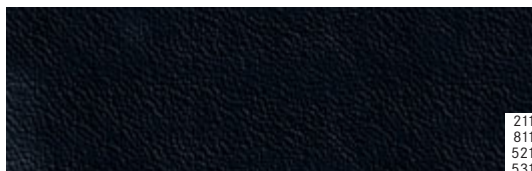
211
811
521
531

H15



731



H14



H18



736

BLACK/BLACK

- 011 Fabric
- 211 Leather
- 811 PASSION leather
- 521 Exclusive PASSION leather
- 531 Exclusive PASSION leather (only for V 12)

TRIM PARTS

- H15 dark brown eucalyptus (standard)
 - 731 dark burr walnut (high-sheen)
 - H14 light burr walnut (high-sheen)
 - H18 brown poplar (only for V 12)
 - 736 black ash (only for AMG Sports package)
-



The alpaca grey/basalt grey colour scheme includes optional leather upholstery (standard for long-wheelbase version) as well as the lower dashboard section, centre console, door interiors and carpets in alpaca grey. The upper section of the dashboard, steering wheel and the door edges are finished in basalt grey. The same colour combination is available in PASSION leather or Exclusive PASSION leather (for the long-wheelbase version) as an extra-cost option. The latter option includes a PASSION leather trim for the dashboard, door linings, seatback panels, ruffled pockets and parcel shelf. A further elegant touch is provided by the roof liner and the A-, B- and C-pillars in Alcantara®.

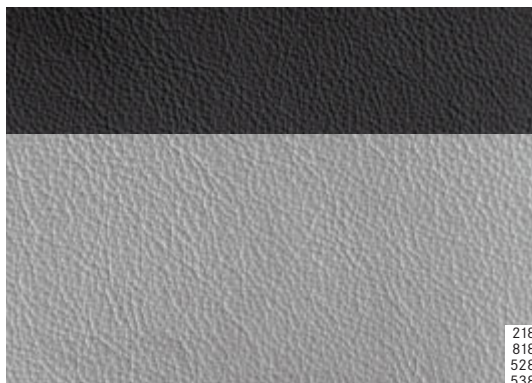

218
818
528
538



H15



731



H14



H18



736

ALPACA GREY/BASALT GREY

- 218 Leather
- 818 PASSION leather
- 528 Exclusive PASSION leather
- 538 Exclusive PASSION leather (only for V12)

TRIM PARTS

- H15 dark brown eucalyptus (standard)
- 731 dark burr walnut (high-sheen)
- H14 light burr walnut (high-sheen)
- H18 brown poplar (only for V12)
- 736 black ash (only for AMG Sports package)



The cashmere beige/savanna beige colour scheme includes optional leather upholstery (standard for long-wheelbase version) as well as the lower dashboard section, centre console, door interiors and carpets in cashmere beige. The upper section of the dashboard, steering wheel and door edges are finished in savanna beige. The same colour combination is available in PASSION leather or Exclusive PASSION leather (for the long-wheelbase version) as an extra-cost option. The latter option includes a PASSION leather trim for the dashboard, door linings, seatback panels, ruffled pockets and parcel shelf. A further elegant touch is provided by the roof liner and the A-, B- and C-pillars in Alcantara®.

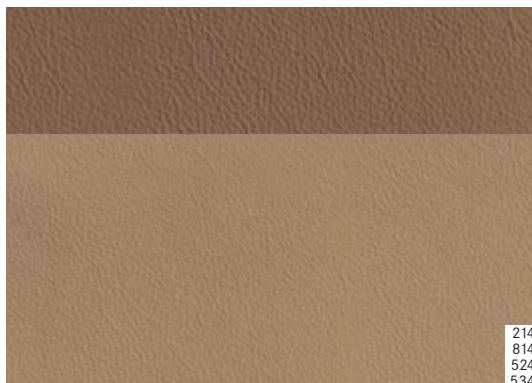

214
814
524
534



H15



731



H14



H18



736

CASHMERE BEIGE/SAVANNA BEIGE

- 214 Leather
- 814 PASSION leather
- 524 Exclusive PASSION leather
- 534 Exclusive PASSION leather (only for V 12)

TRIM PARTS

- H 15 dark brown eucalyptus (standard)
- 731 dark burr walnut (high-sheen)
- H 14 light burr walnut (high-sheen)
- H 18 brown poplar (only for V 12)
- 736 black ash (only for AMG Sports package)



The sahara beige/black colour scheme includes optional leather upholstery (standard for long-wheelbase version) as well as the lower dashboard section, upper centre console section and door interiors in sahara beige. The upper section of the dashboard, steering wheel, lower section of the centre console, door edges and carpets are finished in black. The same colour combination is available for the optional PASSION leather or Exclusive PASSION leather (for the long-wheelbase version) variants. The latter option includes a PASSION leather trim for the dashboard, door linings, seatback panels, ruffled pockets and parcel shelf. A further elegant touch is provided by the roof liner and the A-, B- and C-pillars in Alcantara®.

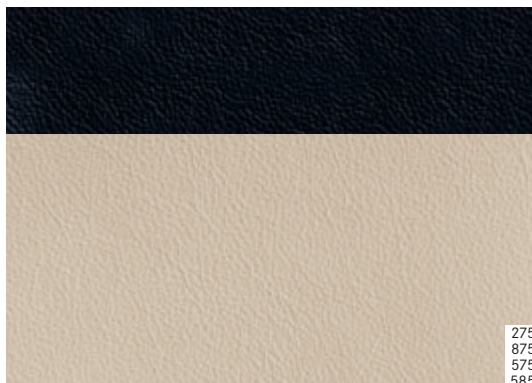

275
875
575
585



H15



731



H14



H18



736

SAHARA BEIGE/BLACK

- 275 Leather
- 875 PASSION leather
- 575 Exclusive PASSION leather
- 585 Exclusive PASSION leather (only for V 12)

TRIM PARTS

- H15 dark brown eucalyptus (standard)
- 731 dark burr walnut (high-sheen)
- H14 light burr walnut (high-sheen)
- H18 brown poplar (only for V 12)
- 736 black ash (only for AMG Sports package)



The chestnut brown/black colour scheme includes optional leather upholstery (standard for long-wheelbase version) as well as the lower dashboard section, centre console and door interiors in chestnut brown. The upper section of the dashboard, steering wheel, door edges and carpets are finished in black. The same colour combination is available for the optional PASSION leather or Exclusive PASSION leather (for the long-wheelbase version) variants. The latter option includes a PASSION leather trim for the dashboard, door linings, seatback panels, ruffled pockets and parcel shelf. A further elegant touch is provided by the roof liner and the A-, B- and C-pillars in Alcantara®.

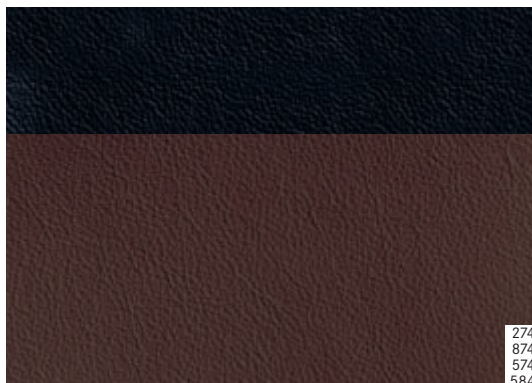

274
874
574
584



H15



731



H14



H18



736

CHESTNUT BROWN/BLACK

- 274 Leather
- 874 PASSION leather
- 574 Exclusive PASSION leather
- 584 Exclusive PASSION leather (only for V 12)

TRIM PARTS

- H 15 dark brown eucalyptus (standard)
 - 731 dark burr walnut (high-sheen)
 - H 14 light burr walnut (high-sheen)
 - H 18 brown poplar (only for V 12)
 - 736 black ash (only for AMG Sports package)
-

Wheels



17-inch 7-spoke light-alloy wheel
(standard for V6 engines)



18-inch 5-spoke light-alloy wheel
(standard for V8 engines)



18-inch 5-spoke light-alloy wheel
(standard for V12 engine)



18-inch 7-twin-spoke light-alloy wheel with high-shine finish
(optional extra)



18-inch 9-spoke light-alloy wheel
(optional extra)



18-inch 10-spoke light-alloy wheel
(optional extra)



19-inch 9-twin-spoke light-alloy wheel
(optional extra)



19-inch multi-spoke light-alloy wheel (optional extra)



20-inch AMG 5-twin-spoke light-alloy wheel
(optional extra)



20-inch incenio "Kiyali" 5-spoke light-alloy wheel
(genuine accessories)



20-inch incenio "Alaraph" 10-spoke light-alloy wheel
(accessory wheel available ex factory)

Genuine accessories

A Mercedes-Benz is more than just a car. It can be a travel companion, an office, a living space. And this diversity is reflected in the Mercedes-Benz genuine accessories range



incenio "Nuklida" 19-inch light-alloy wheel, titanium-silver surface with a high-shen finish

The range of Mercedes-Benz genuine accessories for the S-Class is designed to make driving even more of an enriching experience. 19-inch incenio "Nuklida" light-alloy wheels are available to further enhance the car's appearance. The 5-Y-spoke design really catches the eye – whether the car is moving or still.

Refined details such as the high-quality illuminated door sills in polished stainless steel with Mercedes-Benz lettering give your S-Class the perfect finishing touch.

Safe and reliable transport of bulky items such as skis, large pieces of luggage or even bicycles is assured by a range of flexible rack systems

and roof boxes in three sizes. The roof boxes are made from exceptionally durable material.

The dust cover, made from flexible carbon-fibre material, protects your S-Class against dirt,

dust and scratches (vehicle cover for the garage or other interior spaces).

The range of genuine accessories offers you a wide selection of high-quality items to choose

from. Please see our accessories brochure for further details, or contact your Mercedes-Benz dealership, who will be happy to advise you.



Illuminated door sill panels with "Mercedes-Benz" lettering



Basic carrier bars and Mercedes-Benz roof box



Genuine Mercedes-Benz dust cover

Technical data

	DIESEL ENGINES			PETROL ENGINES	
	S 350 CDI BlueEFFICIENCY	S 350 CDI 4MATIC BlueEFFICIENCY	S 450 CDI	S 350	S 350 4MATIC
Arrangement/ number of cylinders	V6	V6	V8	V6	V6
Total displacement (cc)	2987	2987	3996	3498	3498
Rated output ¹ (kW at rpm)	173/3600	173/3600	235/3600	200/6000	200/6000
Rated torque ¹ (Nm at rpm)	540/1600–2400	540/1600–2400	730/2200	350/2400–5000	350/2400–5000
Compression ratio	17.7	17.7	17.0	10.7	10.7
Acceleration from 0–100 km/h (s) (long-wheelbase version)	7.8 (7.8)	7.8 (7.8)	6.6 (6.6)	7.3 (7.3)	7.3 (7.3)
Top speed approx. (km/h) (long-wheelbase version)	250 ² (250 ²)	245 (245)	250 ² (250 ²)	250 ² (250 ²)	250 ² (250 ²)
Tyre size, front	235/55 R 17	235/55 R 17	255/45 R 18	235/55 R 17	235/55 R 17
Tyre size, rear	235/55 R 17	235/55 R 17	255/45 R 18	235/55 R 17	235/55 R 17
Fuel	Diesel	Diesel	Diesel	Premium petrol	Premium petrol
Fuel consumption ³ (l/100 km)					
Urban (long-wheelbase version)	10.4–10.6 (10.5–10.7)	10.7–10.9 (10.7–10.9)	13.0–13.2 (13.0–13.2)	14.6–14.8 (14.6–14.8)	14.6–15.0 (14.7–15.1)
Extra-urban (long-wheelbase version)	5.9 (6.0)	6.2–6.3 (6.2–6.3)	6.9–7.1 (6.9–7.1)	7.4–7.7 (7.4–7.7)	7.8–7.9 (7.9–8.0)
Combined (long-wheelbase version)	7.6 (7.7)	7.8–8.0 (7.8–8.0)	9.1–9.3 (9.1–9.3)	10.0–10.2 (10.0–10.2)	10.2–10.5 (10.3–10.6)
CO ₂ emissions ³ (g/km) combined (long-wheelbase version)	199–201 (202–204)	207–211 (207–211)	240–245 (240–245)	234–237 ⁴ (234–237 ⁴)	240–245 ⁴ (242–247 ⁴)
Tank capacity (l)/incl. approx. reserve	90/11	90/11	90/11	90/11	90/11
Boot capacity (l)	560	560	560	560	560
Turning circle diameter (m) (long-wheelbase version)	11.8 (12.2)	11.8 (12.2)	11.8 (12.2)	11.8 (12.2)	11.8 (12.2)
Kerb weight ⁵ (kg) (long-wheelbase version)	1955 (2005)	2030 (2070)	2090 (2150)	1895 (1955)	1955 (2025)
Permissible GVW (kg) (long-wheelbase version)	2550 (2585)	2630 (2655)	2690 (2700)	2490 (2535)	2555 (2610)

¹ Figures in accordance with Directive 80/1269/EEC in the currently applicable version ² Electronically limited ³ The figures shown were obtained in accordance with the prescribed measuring process (Directive 80/1268/EEC in the currently applicable version). The figures are not based on an individual vehicle and do not constitute part of the product offer; they are provided solely for purposes of comparison between different vehicle models ⁴ Meets requirements of EU5 emission standard

S 450	S 450 4MATIC	S 500	S 500 4MATIC	S 600 ⁵	S 63 AMG	S 65 AMG ⁶	ALTERNATIVE DRIVE S 400 HYBRID
V8	V8	V8	V8	V12	V8	V12	V6
4663	4663	5461	5461	5513	6208	5980	3498
250/6000	250/6000	285/6000	285/6000	380/5000	386/6800	450/4800-5100	205 + 15/6000
460/2700-5000	460/2700-5000	530/2800-4800	530/2800-4800	830/1800-3500	630/5200	1000/2000-4000	385/2400-5000
10.5	10.5	10.7	10.5	9.0	11.3	9.0	11.7
5.9 (5.9)	5.9 (5.9)	5.4 (5.4)	5.4 (5.4)	(4.6)	4.6 (4.6)	(4.4)	7.2 (7.2)
250 ² (250 ²)	250 ² (250 ²)	250 ² (250 ²)	250 ² (250 ²)	(250 ²)	250 ² (250 ²)	(250 ²)	250 ² (250 ²)
255/45 R 18	255/45 R 18	255/45 R 18	255/45 R 18	255/45 R 18	255/40 ZR 19	255/35 ZR 20	235/55 R 17
255/45 R 18	255/45 R 18	255/45 R 18	255/45 R 18	275/45 R 18	275/40 ZR 19	275/35 ZR 20	235/55 R 17
Premium petrol	Premium petrol	Premium petrol	Premium petrol	Super Plus	Super Plus	Super Plus	Premium petrol
15.9-16.0 (16.0-16.3)	16.3-16.4 (16.3-16.4)	16.5-16.7 (16.6-16.8)	16.8-16.9 (16.8-16.9)	(21.7)	22.2 (22.4)	(21.9)	10.7-10.9 (10.8-11.0)
7.7-7.8 (7.8-8.0)	7.9-8.0 (7.9-8.0)	7.9-8.1 (8.0-8.2)	8.1-8.2 (8.1-8.2)	(10.0)	9.9 (10.0)	(10.2)	6.3-6.5 (6.4-6.6)
10.6-10.7 (10.7-11.0)	11.0-11.1 (11.0-11.1)	11.0-11.2 (11.1-11.3)	11.3-11.4 (11.3-11.4)	(14.3)	14.4 (14.5)	(14.5)	7.9-8.1 (8.0-8.2)
249-251 ⁴ (251-257 ⁴)	256-258 ⁴ (256-258 ⁴)	258-262 ⁴ (260-264 ⁴)	264-266 ⁴ (264-266 ⁴)	(340)	344 (347)	(346)	186-189 ⁴ (188-191 ⁴)
90/11	90/11	90/11	90/11	90/11	90/14	90/14	90/11
560	560	560	560	550	560	550	560
11.8 (12.2)	11.8 (12.2)	11.8 (12.2)	11.8 (12.2)	(12.2)	11.8 (12.2)	(12.2)	11.8 (12.2)
1955 (2015)	2030 (2075)	1955 (2015)	2030 (2075)	(2210)	2070 (2140)	(2270)	1955 (2020)
2560 (2595)	2640 (2660)	2560 (2595)	2640 (2660)	(2690)	2610 (2640)	(2705)	2550 (2600)

⁵ Figures according to Directive 92/21/EC, version 95/48/EC (kerb weight with fuel tank 90% full, driver, 68 kg, and luggage, 7 kg) for standard-specification vehicles. Optional extras and accessories will generally increase this figure and reduce the payload capacity accordingly

⁶ Only available as long-wheelbase version

Dimensions

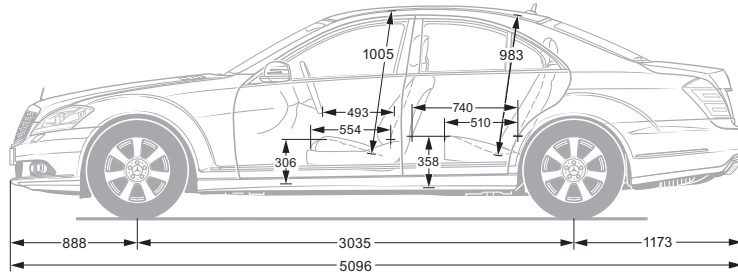

S-Class

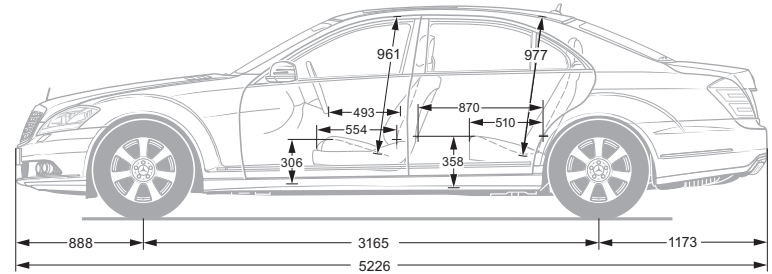

Long-wheelbase S-Class

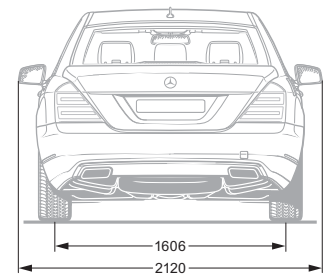
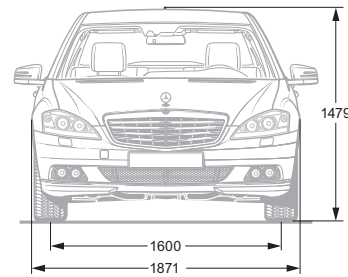
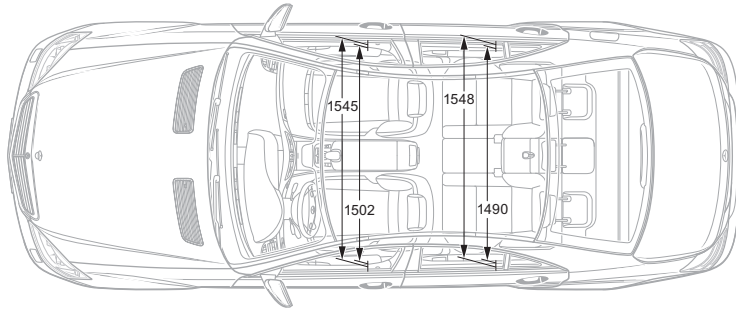

Services

Experience Mercedes-Benz at first hand. It all started in Berlin at the end of 2000: the concept of the car dealership was reinvented with the opening of the first Mercedes-Benz Centre. Featuring the entire Mercedes-Benz model line-up as well as the accessories range, brand merchandise and an attractive programme of events, the Centres offer a welcoming environment in which to experience the brand at first hand. But it's not just in major cities that you can experience the legendary Mercedes-Benz brand and service. A close-knit network of company-owned branches and authorised dealers ensures that you are never far from the wide range of services, the comprehensive customer care and the high quality which you expect from Mercedes-Benz. And you can count on their support at every stage – before you buy your Mercedes, during the purchase process and, most importantly, for a long time afterwards, too.

Mercedes-Benz Museum. More than 120 years of automotive history in one place – this is what awaits you at the Mercedes-Benz Museum in Stuttgart. Experience the unique excitement, and embark upon a thrilling journey through time. Housed inside an architecturally impressive building, over 1500 exhibits on nine levels give you an insight into the unique tradition and powers of innovation of the Mercedes-Benz brand. Plus you can see the world's first two automobiles in the shape of the Benz Patent-Motorwagen (motor car) and the Daimler motorised carriage – both from the year 1886. Two linked circuits take you from the beginnings of the automobile, past a series of unforgettable classics, through over 100 years of motor racing history and, finally, on to a glimpse of what the future holds – in an area covering a total of 16,500 square meters. Enjoy the unique brand experience. We look forward to your visit. For more information, please visit www.mercedes-benz.com/museum

MercedesCard. Your ticket to the Mercedes-Benz experience: four times a year, we will send you exciting details of a selected range of events and services, which we have put together exclusively for you. Then there is the Mercedes magazine with its fascinating reports and articles. But the MercedesCard also has many other uses: as a VISA credit card, it is an internationally accepted means of payment. Answer the annual questionnaire and we'll even waive the card fee. Plus the card offers further benefits to provide you with peace of mind, such as the Mercedes-Benz insurance package at no extra charge and the exclusively compiled MercedesCard insurance package at a preferential price. You can also gain free entry to the Mercedes-Benz Museum simply by showing your VISA MercedesCard. Further information can be found at www.mercedes-benz.de/mercedescard¹

¹ Information about the MercedesCard in Austria and Switzerland can be found on the Mercedes-Benz websites for these countries

Mercedes-Benz mobility. There will always be a helpful passenger in your new Mercedes-Benz: the assurance of carefree driving. If you should ever need assistance, the Mercedes-Benz Service24h is there for you round the clock, 365 days a year. Our specialists are there to assist you in your own language if you telephone the freephone service hotline on 00800 1 777 7777¹. The newly integrated telematics service Mercedes-Benz Contact² is even more customer-friendly: it enables you to make contact with the Mercedes-Benz customer centre by telephone at the touch of a button. And if you wish, all the relevant vehicle and position-related data can be transmitted, so that your adviser has all the important information right from the start of the telephone conversation, thus ensuring the shortest possible reaction time, individual service and rapid on-the-spot help. As standard and at no extra charge: the Mercedes-Benz mobility package Mobilo – our 4-year warranty for your

mobility³. Whether you have lost your key, are having problems starting your car or have had a breakdown which cannot be repaired immediately – Mobilo ensures that you still reach your destination – anywhere in the whole of Europe, even if the vehicle is damaged as a result of an accident or vandalism. Should a repair take a little longer, we will even cover the cost of an overnight stay. But don't get too excited – after all, it's very rare for a Mercedes to break down. Whatever the nature of your problem, one thing is for certain: you will soon be able to resume your journey, satisfied that the problem has been solved.

¹ Charges for calls made from mobile phones may vary, depending on service provider

² Requires factory-fitted radio and a switched-on mobile phone. The only charge incurred is the cost of the mobile-phone call to the landline network

³ When the warranty has expired Mobilo can be extended by another year for a maximum of 30 years, provided that regular maintenance is carried out by your Mercedes-Benz service partner

⁴ 9 ct/min from Deutsche Telekom landlines, mobile-phone rates may vary

Mercedes-Benz Bank. If you have already chosen your dream car and want to remain financially flexible, you should make us your next port of call, whether it be for leasing, finance, insurance or service packages. Our “Private Leasing Plus” scheme is a complete package comprising leasing, third-party insurance and fully-comprehensive insurance. “Business Leasing Plus” for business customers works in much the same way, while our Plus3 Financing combines the low repayment rates of a financing scheme with the flexibility of leasing. You then have three options at the end of the contract: you can keep the car, sell it or return it to us for a guaranteed price and switch to a new model. We can also offer a range of investment products such as fixed-interest products, savings plans, investment funds or depository receipts. For details, please call 01803/32 22 65⁴ or visit www.mercedes-benz-bank.de

Test drive. A Mercedes-Benz is most at home on the road. This is the only way to experience the effortlessly superior driving feel that lends every Mercedes model its inimitable class. Feel the power of efficient engines with low fuel consumption and precise steering, designed to put you right in the mood for driving. And experience what true comfort really is. The unique feeling of driving a Mercedes cannot be put into words, however. Which is precisely why we'd like to invite you to take a test drive. Your Mercedes-Benz dealer will be happy to make all the necessary arrangements for you. Simply visit www.mercedes-benz.com to locate the nearest Mercedes-Benz dealer in your country or region. We look forward to seeing you.

Interactive Owner's Manual. The website also offers an interactive tour, enabling you to take a closer look at your desired model. This simulation is the ideal way to acquaint yourself with your dream car. You can view key functions in detail, gain an insight into the car's inner workings or look at the benefits of each model. For further details, visit www.mercedes-benz.de/owners-manual

Mobile internet. Now your mobile phone acts as a gateway to the whole Mercedes-Benz world. In addition to an overview of all passenger car models, there are insights into the entire brand world, not to mention a wealth of entertainment offers and direct links to a range of services at www.mercedes.mobi

Take-back of end-of-life vehicles. Coming full circle. At the end of its long life, you can return your S-Class to us for environment-friendly disposal in accordance with the EC End-Of-Life Vehicle Directive¹. But that day lies a long way off.

¹ Applies in accordance with national regulations to vehicles up to 3.5 tonnes gross weight. Mercedes-Benz passenger cars have met the statutory regulations governing the suitability of their design for reuse and recycling for a number of years now. A network of vehicle take-back depots and dismantlers has been established which will process your vehicle in an environment-friendly manner. The ways in which both vehicles and parts can be recovered are subject to ongoing development and improvement. Consequently, the S-Class will be able to comply with any future increases in the recycling quota within the stipulated time limits. Further information is available at www.mercedes-benz.de or by calling 00800 1 777 7777

Please note: changes may have been made to the product since this brochure went to press (04.09.2009). The manufacturer reserves the right to make changes to the design, form, colour and specification during the delivery period, provided these changes, while taking into account the interests of the vendor, can be deemed reasonable with respect to the purchaser. Where the vendor or the manufacturer uses symbols or numbers to describe an order or the subject of an order, no rights may be derived solely from these. The illustrations may show accessories and items of optional equipment which are not part of standard specification. Colours may differ slightly from those shown, owing to the limitations of the printing process. This brochure has been compiled by Daimler AG of Germany and is distributed internationally. It provides a general indication of the range of models, features, optional extras, colours and/or services available in various countries. Some of the models, features, optional extras, colours and/or services may not be available in your country, or may only be available in a different specification. Additionally some models, features, optional extras, colours and/or services may only be available in combination with others. For current and more specific information in relation to the range of models, features, optional extras, colours and/or services available in your country, and their pricing, you should contact your nearest authorised Mercedes-Benz Passenger Car Dealer. www.mercedes-benz.com