



Clase R

Mercedes-Benz

“Our philosophy is very simple.
We give our best for people who expect the best.”

Dr Dieter Zetsche

The R-Class

COMFORT	12
Design	14
Cockpit	16
5-seater	18
Seating variants	26
Long-wheelbase version	30
<hr/>	
AGILITY	32
BlueEFFICIENCY	34
Diesel engines	36
Petrol engines	38
Transmission	40
Drive system and chassis	42
<hr/>	
SAFETY	46
Safe driving	48
In the event of danger	50
In an accident	52

My R-Class

	54
EQUIPMENT	56
Standard equipment	58
Light-alloy wheels	60
Optional extras	64
Chrome package	76
Sports packages	78
Two-tone interior design	82
<hr/>	
GENUINE ACCESSORIES	84
<hr/>	
COLOURS AND MATERIALS	86
Paint finishes	86
Upholstery and leather	88
Wood and trim elements	90
Possible combinations	92
<hr/>	
TECHNICAL DETAILS	94
Technical data	94
Dimensions	96
<hr/>	
SERVICES	98

Why shouldn't car passengers be able to go first-class too?

The R-Class – more room for individuality

The unending vastness of the sea, a cloudless sky or unspoiled landscapes – space has always been the best form of rest and relaxation. One good example is the R-Class, the SUV tourer from Mercedes-Benz. Thanks to its generous and variable interior, it not only ensures an unrivalled atmosphere, but also impressive long-distance comfort.

In standard specification the SUV tourer is a 5-seater with three seats in the second row, however it is also optionally available with six or seven seats. In the 5-seater there is a multi-use luggage compartment which offers an unbeatable capacity of 2436 litres in the long version.

In addition to generous interior space, the R-Class provides outstanding flexibility: two different wheelbases, rear-wheel or 4MATIC all-wheel drive, efficient engine variants and a more striking appearance with particularly sporty styl-

ing and 18-inch light-alloy wheels (17-inch for the R 300 CDI BlueEFFICIENCY and R 350 BlueTEC 4MATIC, 19-inch for the R 500 4MATIC). Accordingly the R-Class not only makes its mark through its appearance, but also with 14 different base versions which offer you numerous choices. Other features include an optional two-tone interior design, luxurious materials and technical highlights to make driving even more enjoyable.

A range of smooth, powerful engines ensures an effortless, carefree driving experience: three diesels and three petrol powerplants are available. If even more traction is required, you can opt for the 4MATIC all-wheel-drive system. Additional safety is ensured by the standard-fit PRE-SAFE® anticipatory occupant protection system.

Wherever you are going – the R-Class is a vehicle for people who enjoy life while wanting to retain their independence.



















The feel-good class

Discover a new dimension of comfort

Leather, wood, chrome and even air – there are many reasons why the R-Class creates a sense of wellbeing in its occupants which few other cars can rival. Take the standard-fit steel suspension, for example. Even when the vehicle is fully laden, it provides a particularly comfortable ride. The R 500 4MATIC and the 5+2-seater are even equipped with rear air suspension including level control. Specify the optional AIRMATIC package, consisting of all-round air suspension and the Adaptive Damping System (ADS), and you'll feel as if you really are riding on air.

In the interior the driver and front passenger will find luxurious “executive chairs” awaiting them. Behind them is where all the versatility starts. The R-Class comes in a 5-seater variant as standard, featuring a large stowage compartment recessed into the floor of the luggage compartment. On request it is also available as a 6-seater or 7-seater. In the 4+2 and 5+2-seater versions, an extra row of seats replaces the stowage compartment. Other options ensure the ultimate listening pleasure for your passengers: you can compile your own programmes with the Rear Seat Entertainment package. At the same time just the right interior temperature can be selected with the optional THERMOTRONIC luxury automatic climate control system, which has a separate air conditioner for the rear.

Whatever your destination – the R-Class makes every journey worthwhile.





The next best thing to taut lines? Flowing curves

The interior: a gripping narrative that will always engage your interest

The sense of power generated by the R-Class is immediately apparent inside the vehicle, too. Our designers have created a compelling interplay of convex and concave forms, edges and curves, light and shadow. Tautness and fluidity alternate and fill the interior with life. The design team's inspiration for the cockpit – a “horizontal muscular structure” – is reflected in the curved forms of the dashboard, door panels and tunnel cover elements.

As they developed the interior, the R-Class design team worked on the basis that “something that looks good has to feel good, too”. Tangible evidence of their commitment to this principle is provided by the switches and knobs with their “soft-feel” coating as well as by the soft armrests or the aluminium and fine wood trim elements. The result is a harmoniously balanced interior which is as pleasing to the touch as it is to the eye.

The two-tone interior design
in black/alpaca grey
is optionally available



We bend over backwards to make sure that you don't have to

Intelligent technology optimises the ergonomics of the R-Class

Although we would be the first to admit that the sense of wellbeing you experience in a Mercedes is difficult to put into words, we have nevertheless succeeded in turning it into a precise science.

Using a highly advanced computer simulation technique, we are able to design exceptionally ergonomic interiors. With some particularly clever 3-D technology, we can re-create human behaviour and movement patterns – such as putting on a seat belt or switching on the radio – with absolute precision at the click of a mouse. We can even see things through the driver's eyes in order to determine if the steering wheel provides a clear enough view of the instrument cluster or to check the field of vision offered by the mirrors. Of course, everybody is different. That is why we have loaded our computers with data describing thousands of people, representing a wide spectrum of the population. These data – which comprise factors such as gender, age, body size and sitting

posture – ensure that you and your R-Class form a perfect team.

The driver's seat with optional lumbar support also plays a part. A memory package which remembers the settings for the seat, exterior mirrors and the steering column is available for the R-Class as an option. You have control over the spaciouly designed interior from the driver's seat, whilst control buttons for the multifunction display, radio and telephone are located on the steering wheel. Two ergonomically positioned steering-wheel gearshift buttons and the associated DIRECT SELECT gearshift for the 7G-TRONIC automatic transmission are located behind the steering wheel.

The centre console brings together all the controls for the interior temperature settings, communication systems and the optional COMAND APS multimedia system.

First-class travel, even in the second row

Luxury appointments in the rear

The rear occupants of the R-Class are able to lean back and relax in comfort on the 3-seater bench: the second seat row has two luxurious executive chairs and a comfortable centre seat as standard.

The optional CD/DVD player in the Rear Seat Entertainment package is located in the centre console, between the driver and front passenger seats. It enables passengers in the rear to watch films on 8-inch screens mounted on the head restraints of the front seats – or even television if the optional TV tuner is specified. Up to two games consoles can also be connected.

The rear face of the centre console is equipped with a 12V socket. This face also accommodates the controls for the optional multi-zone luxury automatic climate control THERMOTRONIC with an additional rear air conditioning unit. The additional nozzles for this are located in the rear sidewall panels.





Ideally situated, superb views, 2.217 m x 1.246 m living area

The spaciousness and flexibility of the R-Class

The R-Class is so accommodating that it feels like a real home from home. With a load compartment length of 1.982 m (2.217 m in the long-wheelbase version) and a width of 1.246 m, it is the roomiest passenger car we have ever built. Which explains why you can easily stow six suitcases on board: folding all the rear seats down produces a level loading surface extending from the front seat backrests to the tailgate. And thanks to the low loading height of 695 millimetres, loading the R-Class is no problem either.

Loading is made even more straightforward with the optional EASY-PACK tailgate. This is an electro-hydraulic tailgate that can be opened and closed by means of a remote control unit or switch. This option also includes a useful load compartment cover, but if preferred these two features can also be ordered independently.





Load compartment floor

In standard specification the R-Class is a 5-seater with a large stowage compartment recessed into the load compartment floor. In this way the generous luggage space is supplemented with an additional 51-litre stowage compartment



We attach particular importance to the safety of the little ones

The child safety seat concept of the R-Class

The R-Class also scores heavily as a family car. Even junior family members benefit from the extraordinarily generous interior space, with room for up to three child seats in the second seat row. And because the comfort and safety of our future customers is particularly dear to our heart, the two outer seats are fitted with ISOFIX child seat attachments which enable the seat to be directly anchored to the vehicle body. A high level of safety is possible when you install a child seat on the

front passenger seat: the optional automatic child seat recognition system deactivates the front passenger airbag as soon as it detects a child seat on the front passenger seat. You only need to ensure that you use a special child seat equipped with a transponder, which is available as a Mercedes-Benz accessory. So as you see, even a large family will not stretch the R-Class to its limits.



Rest and relaxation should begin during the journey

Whether for professional or private use - the R-Class has the right answers for practically any day-to-day requirements. The generously dimensioned 5-seater with its highly intelligent spatial concept will always deliver you and your passengers to your destination in a relaxed state of mind. Thanks to maximum variability, as the interior of the R-Class is truly a quick-change artist. For example, the centre section of the second seat row in the 5-seater can simply be

folded down when required, transforming it into a practical and comfortable centre armrest. And should you need to carry something particularly large or bulky, completely folding down the rear seats opens up an impressive loading capacity of up to 2001 litres, with a maximum depth of 1.982 metres. Because one thing is certain: the limits of your possibilities should only be defined by you - and not by your vehicle.





The rear of the 4+2-seater R-Class with the optional rear centre console in the second seat row

The R-Class: group travel is back in style

Space and comfort for up to seven occupants

As an option the R-Class can be equipped with three seat rows, eliminating the stowage compartment in the load compartment floor as a result. As a 4+2-seater it not only offers generous space, but also comfortable single seats with armrests in the second row. By virtue of their width and high-quality upholstery, these provide a level of comfort similar to the front seats. A rear centre console with two cup holders and numerous stowage facilities is available as an option. If preferred the R-Class can also be ordered as a 5+2-seater. This version of the SUV tourer is equipped with rear air suspension and level control as standard. The EASY-ENTRY system, which is provided in conjunction with the 4+2 and 5+2-seater, makes getting in and out of the car particularly convenient.

The single seats in the third row are identically available for the 4+2 and 5+2-seater



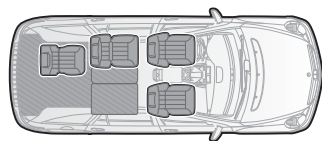
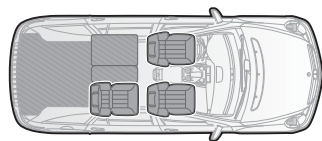
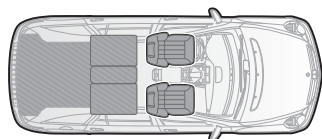

Whether in the standard 5-seater or the optional 4+2 and 5+2-seater – all the seats can be individually folded down for the greatest possible versatility



5-seater (standard specification)



4+2-seater (optional)

Up to seven luxury seats on request

The variable seating concept of the R-Class

The interior of the R-Class not only offers generous personal space, but also plenty of room for the imagination. The SUV tourer has five seats as standard, but two, three, four, six or seven seats are also possible. If only two seat rows are occupied and the 5-seater is loaded to roof level, a maximum load capacity of 939 litres is available (888 litres in 4+2 and 5+2-seater). As a two-seater, the base version of the R-Class offers a load

capacity of 2001 litres when loaded to roof level, or 1950 litres in the 4+2 and 5+2-seater. Reconfiguring the interior in this way is quick and easy: creating a level load area is simply a matter of folding the cushions and backrests of the second and third rows forward. And even with a full complement of seven occupants, the luggage compartment still has up to 324 litres of space for light baggage when loaded to roof level.



5+2-seater (optional)

An extra measure of greatness

The 5.173 m long-wheelbase version leaves nothing to be desired

The R-Class is already multi-talented in the standard length of 4.938 metres. If even this is not enough, why not opt for the long-wheelbase version? The advantage is that if six or seven occupants are on board, those sitting in the second and third seat row will be even more comfortable. With even more room for luggage as well – in fact a load capacity of 414 litres to roof level. If only the first and second seat rows are in use, the load capacity of the 5-seater is 1118 litres, or 1067 litres in the 4+2 and 5+2-seater (179 litres more than in the standard version). You also benefit from a load compartment that's 1.075 metres long.

In the 4+2 and 5+2-seater versions, the seats in the second row can be moved fore or aft individually to create a distance of up to 990 mm to the front row of seats – a degree of spaciousness and comfort comparable to that found in luxury saloons. The telling difference in the R-Class: in two-seater configuration, the long-wheelbase version can, if required, offer a maximum load capacity of up to 2436 litres in the 5-seater version and 2385 litres for the 4+2 and 5+2-seater (435 litres more than the standard version) while the maximum loading length grows to 2.217 metres. That means plenty of space for a surfboard, mountain bike or any number of holiday souvenirs. (The R 300 CDI 4MATIC is not available in long-wheelbase form.)

In comparison

The 235 mm longer R-Class provides not only more stowage facilities, but enhanced comfort, too

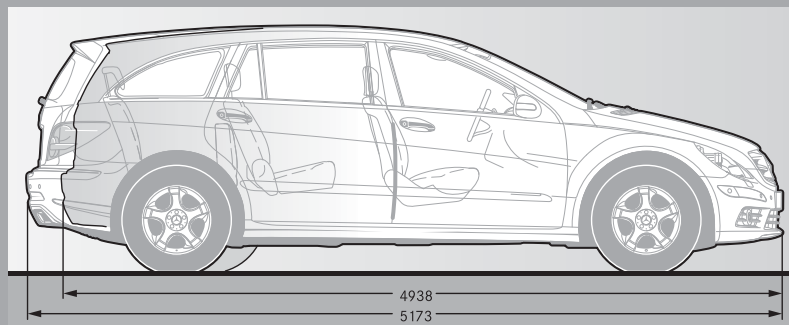



Agility

14 solid arguments in favour of the R-Class

Versatility is the key: powerful engines, rear-wheel or all-wheel drive and air suspension

With a total of 14 base versions, the R-Class offers an enormous range of configurations. It will also surprise you with its wealth of technical refinements and agility levels that make every trip a real pleasure. There is also a choice of rear-wheel or all-wheel drive models: the V6 petrol-engined R 300 and the V6 diesel-version R 300 CDI BlueEFFICIENCY have rear-wheel drive, the V6 petrol-version R 350 and the V6 diesel-version R 300 CDI are available with either rear-wheel or all-wheel drive, and the V6 diesel versions R 350 CDI, R 350 BlueTEC 4MATIC as well as the top-of-the-range R 500 with a V8 petrol engine always feature 4MATIC permanent all-wheel drive for extra traction. This system applies specific brake pressure to wheels with insufficient traction, while increasing torque at the wheels with good traction. Whichever engine variant you choose – you will benefit from a suspension that is tailor-made for both winding rural roads and fast motorways. An experience you can heighten even further with the optional AIRMATIC package – all-round air suspension together with the Adaptive Damping System ADS. All these features ensure that driving becomes a relaxed and effortless pleasure.





BlueEFFICIENCY – innovations for efficient mobility

We do not pay lip service to protection of the environment. It's a matter close to our hearts. As the inventor of the motor car, Mercedes-Benz has a special responsibility – one we have undertaken with all our might for many years. We can already offer you 66 models that place far less of a burden on the environment – without having to compromise on safety, comfort and driving enjoyment.

Our BlueEFFICIENCY concept comprises innovations for efficient mobility as well as optimised processes all the way along the value chain. They involve different approaches, but they all have a common goal: to make your individual mobility as sustainable as possible.

The BlueEFFICIENCY measures – the Mercedes-Benz efficiency package. The BlueEFFICIENCY measures are comprehensive vehicle optimisations which save fuel and, therefore, ease the burden on the environment. Each model combines the most efficient engine with optimal aerodynamic and energy-management measures to minimise fuel consumption. Such measures include intelligently controlled ancillaries, tyres with optimised rolling resistance, the ECO start/stop function, lightweight components and an aerodynamically optimised body design. All in all, these measures allow substantial savings to be made: fuel consumption and, therefore, CO₂ emissions are reduced by up to 23 %.

BlueTEC – the clean diesel. Mercedes-Benz has brought to market BlueTEC technology for diesel engines based on common-rail direct injection (CDI). It combines optimised combustion with a modular emission-control system, all of which makes BlueTEC an exceptionally clean diesel technology. Not only does it remove up to 95 % of the particulate from the exhaust gases, it also reduces nitrogen oxides by up to 90 %. All that remains is water, harmless nitrogen and the satisfying feeling of having helped to ease the burden on the environment.

HYBRID – the intelligent combination of petrol and electric drive. A well-established team makes a lot of things easier. And this is certainly



The BlueEFFICIENCY measures bring about a substantial reduction in fuel consumption and CO₂ emissions



BlueTEC filters out up to 95 % of the particulate and converts up to 90 % of the nitrogen oxides into harmless nitrogen

true in the case of HYBRID technology. During braking, the electric motor supplies the battery with kinetic energy. When needed, this energy is forwarded to the electric drive, which assists the petrol engine when the car is accelerating. What's more, the ECU shuts off the petrol engine when the speed falls below 15 km/h. In this way, a HYBRID can reduce fuel consumption by up to 20 %. So it looks after the environment as well as your bank balance. Perfect teamwork, you might say.

BlueTEC HYBRID – clean diesel combined with electric drive. BlueTEC HYBRID technology marries the benefits of HYBRID technology with those of BlueTEC technology: during braking, the

kinetic energy is converted into electrical energy, which can be re-used when required. At the same time, the BlueTEC technology cleans the exhaust gases and removes most of the pollutants.

Innovative drive systems that break new ground. Concept BlueZERO F-CELL, E-CELL and E-CELL PLUS. Mercedes-Benz has developed three further drive concepts with an electric motor and a battery for storing energy as part of its close-to-production Concept BlueZERO: E-CELL with an electric motor, which only draws its energy from the battery; E-CELL PLUS with a battery and an internal combustion engine (Range Extender); and F-CELL with an additional fuel cell for generating power.

But that is not all: under the banner “Design for Environment”, we also look at a vehicle's entire lifecycle – from planning to recycling. The same applies to the building and running of new factories. In addition, Mercedes-Benz is involved in the development of alternative fuels and carries out research in the field of bionics. In short, BlueEFFICIENCY is good news for both you and the environment.

Further information about our comprehensive measures can be found at:
www.mercedes-benz.com/blueefficiency



HYBRID technology reduces fuel consumption by up to 20 %



BlueTEC HYBRID combines clean diesel technology with electric drive, and will be available from 2012

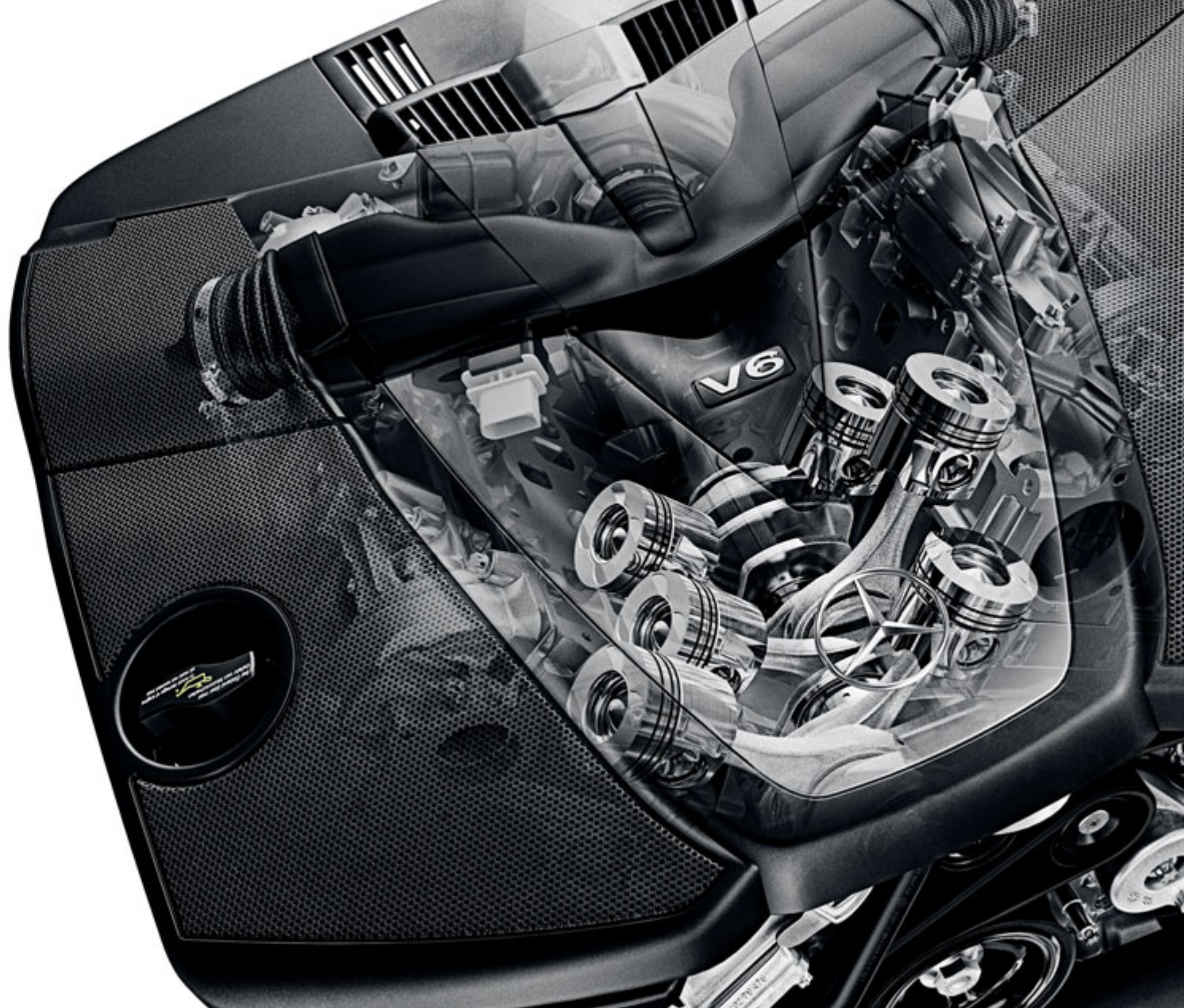

The V6 CDI diesels

The impressive torque figures are the result of optimised common-rail technology with multi-point injection and variable turbocharger

You may not hear much from our diesel engines, but you'll hear plenty about how good they are

The CDI models with the latest-generation common-rail technology

The V6 CDI diesel engines in the R 300 CDI BlueEFFICIENCY and the R 350 BlueTEC 4MATIC are particularly impressive with their exceptional smoothness and enormous torque: the 440 and 540 newton metres which they develop respectively ensure that plenty of power is available, even at low revs. The R 300 CDI BlueEFFICIENCY has an output of 140 kW, while the R 350 BlueTEC 4MATIC develops 155 kW.

These engines combine high output with low fuel consumption and low emissions.

Fuel consumption has been minimised above all in the R 300 CDI BlueEFFICIENCY model, which incorporates measures such as tyres with low rolling resistance and optimised aerodynamics to enhance the efficiency of the entire vehicle.



R 300 CDI BlueEFFICIENCY

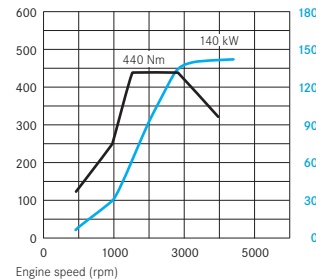

R 350 BlueTEC 4MATIC

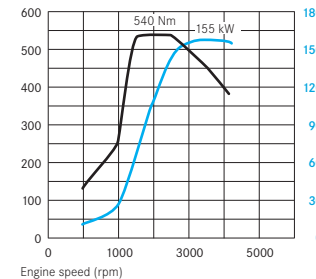

— Torque (Nm) — Output (kW)

The CDI diesel engines
Two ways to be quick off the mark. The V6 CDI engines already develop their maximum torque at low revs

You'll be impressed by the capacity of the engines, too

The V6 and V8 petrol engines for the R-Class: assured performance in every situation

The R 300 and R 350¹ show the sensational effect which can be achieved through understatement. These V6 engines with 4 valves per cylinder and continuous camshaft adjustment provide power and responsiveness in full measure. 170 kW for the R 300 and 200 kW for the R 350¹ provide plenty of pulling power for fast acceleration in any gear. Even in high gear, the petrol engine delivers a relaxed driving experience while returning good fuel economy.

Effortless superiority in any driving situation is the defining characteristic of the 8-cylinder

engine in the R 500 4MATIC. The figures tell their own story: 285 kW and a maximum torque of 530 Nm. The R 500 4MATIC accelerates from 0 to 100 km/h in just 6.1 seconds. Variable intake and exhaust camshafts, as well as extensive use of lightweight materials such as magnesium, ensure excellent fuel economy for this vehicle class. And just to make sure that all this power is delivered as comfortably as possible, the standard 7G-TRONIC automatic transmission does the gearshifting for you.

R 300

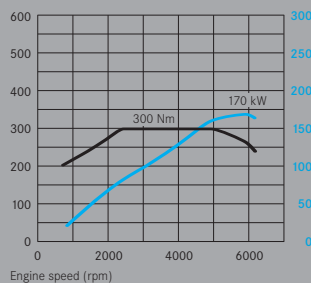

R 350¹

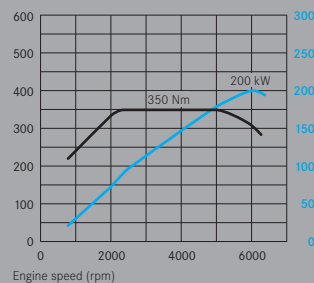

R 500 4MATIC

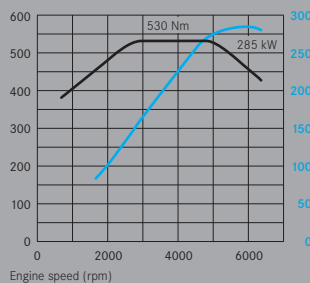

— Torque (Nm) — Output (kW)

¹ Also available as a version with 4MATIC all-wheel drive





Small steps can make a big difference

The 7G-TRONIC automatic transmission is more closely geared to shift more smoothly

The 7G-TRONIC embodies the latest transmission technology to deliver an exceptionally comfortable ride. Seven forward gears mean that the ratios are more closely spaced over a wide ratio spread, with the result that you are hardly aware of the shifting process. When changing down, the 7G-TRONIC's multiple downshift capability means that it can accelerate the process by skipping several ratios. A torque converter lockup clutch, which engages even in first gear, and the transmission control logic also help to save fuel and optimise acceleration.

Thanks to standard-fit DIRECT SELECT gearshift, the centre console in the R-Class remains refreshingly clear: gear selection is easy using the selector lever behind the steering wheel. You can choose between P, R, N and D, without having to take your hand off the steering wheel. There is a choice of two driving programs: "S" for "Sports" and "C" for "Comfort". Whichever program is currently active is indicated in the instrument cluster. Or, if you want to take the shifting process in hand yourself, all you have to do is use the standard-fit DIRECT SELECT steering-wheel gearshift buttons (provided transmission setting D is engaged).



DIRECT SELECT gearshift

Briefly moving the steering-column selector lever is all it takes to select the driving mode

7G-TRONIC

Incorporates more than
40 years' experience
building over eleven million
automatic transmissions





Plenty of space also means plenty of room for top-class technology

Enhanced handling dynamics with the agile suspension and, depending on model, 4MATIC all-wheel drive

The R-Class has a large number of intelligent systems on board. The optional 4MATIC all-wheel-drive system, a sophisticated suspension design, the long wheelbase and numerous dynamic control systems ensure an extraordinarily comfortable journey. Front wheel location is by a double-wishbone axle for improved ride comfort and handling dynamics, while the rear wheels are located by a sophisticated four-link axle. The 5-seater and 4+2-seater feature an all-steel suspension, while the 5+2-seater and R 500 4MATIC have rear air suspension with level control as standard. On request all models are available with the AIRMATIC package, which has all-round air suspension for even greater ride comfort.

Working in combination with the Adaptive Damping System (ADS), the system ensures an improved suspension response even when the vehicle is fully laden. At speeds above 120 km/h the suspension is lowered automatically, thereby reducing drag and, as a consequence, fuel consumption. The AIRMATIC package also allows the suspension to be raised by up to 50 mm at the

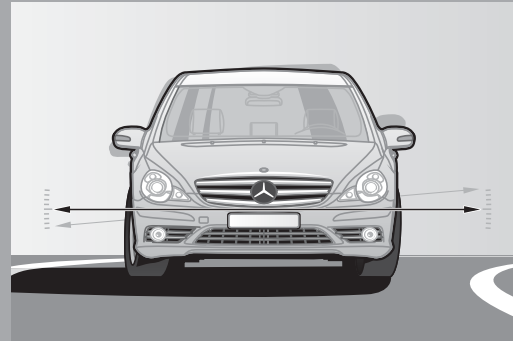

touch of a button in order to increase ground clearance when negotiating poor road surfaces, for example.

You can also count on the assistance of the optional 4MATIC all-wheel-drive system, which distributes the drive torque between the front and rear wheels in a ratio of 50:50. Working in combination with dynamic control systems 4ETS and ESP®, 4MATIC provides a high degree of traction – especially on unstable surfaces, in the wet or on ice or snow.

AIRMATIC package
The air suspension works in conjunction with the Adaptive Damping System (ADS), which automatically optimises the shock-absorber response in accordance with the driving situation. Pitching and rolling – during fast cornering or on poor roads, for example – are reduced as a result





A brown leather-bound book is shown from a high-angle perspective, resting on a dark, scratched metal surface. The book's cover is embossed with the text "THE INTEGRAL SAFETY CONCEPT" on the top line and "FROM MERCEDES-BENZ" on the bottom line. The book has a visible spine on the left and a stack of pages on the right. The lighting creates a strong shadow to the left of the book.

THE INTEGRAL SAFETY CONCEPT
FROM MERCEDES-BENZ

A theory which can save lives in practice

The integral safety concept from Mercedes-Benz

Hardly anything inspires us to produce consistently impressive results quite as much as the research into new safety technology. As early as the 1950s, we reached an important safety milestone when legendary vehicle safety pioneer Béla Barényi invented the passenger safety cell. This era also saw revolutionary ideas put forward by many of our other employees – Rolf Maier, for instance.

In order to study the crash performance of steering and restraint systems quickly and cost-effectively, Rolf Maier and his engineer colleagues designed and built a special sledge which was driven into a wall at high speed. To simulate the crumple zone, the team used gherkin tins from the staff canteen – a simple yet brilliant solution which typifies the creative spirit that characterised this pioneering time.

Of course, much has happened since then. Highly advanced technology now makes our vehi-

cles particularly safe not only in an actual collision. Today, our development activities are focused on measures which bring us closer to our vision of accident-free driving. They are part of our integral safety concept which comprises three areas: this encompasses all the components that support “Safe driving”, identify critical situations in time to give a warning and provide appropriate assistance. In the second phase, “In the event of danger”, the standard-fit PRE-SAFE® system prepares the occupants and the vehicle if there is a high probability of an accident occurring. “In an accident” passengers are provided with appropriate protection during the crash. Also very important is the fact that after an accident, too, a Mercedes is well prepared to provide help such as making it easier to rescue the occupants.



The R-Class can recognise hazards sooner so that you don't have to deal with them later

Avoiding hazardous driving situations is the principal safety goal for the R-Class

The standard-fit Headlamp Assist feature activates the lights entirely automatically to make driving in the dark safer. Bi-xenon headlamps with the active light function, dynamic range adjustment, headlamp cleaning system and cornering light function are available as an optional extra for your R-Class. The active light function follows your steering movements and improves illumination on bends by as much as 90 %. As an option the standard fog lamps can be given the cornering light function, which is automatically activated at speeds of up to 40 km/h when the vehicle is turning or cornering and you operate the indicators, or on tight bends. Also available as an option, the DISTRONIC proximity control system helps you keep your distance from the vehicle ahead when travelling at speeds between around 30

and 180 km/h. The system can brake the car by up to 2 m/s^2 if necessary, and then accelerate it automatically to the preset speed if appropriate.

If there is a risk of skidding – on a wet road, for example – the dynamic handling control systems, which have been specially optimised for the rear-wheel and 4MATIC all-wheel drive of the R-Class, can intervene to provide improved traction. As soon as the sensors detect a critical dynamic handling situation, brake pressure is applied to one or more wheels as required and the engine output may also be adjusted. ESP® and 4ETS work together with the Brake Assist (BAS) and acceleration skid control ASR functions. ESP® trailer stabilisation is also a standard feature.

Active light function
To help you see obstacles at an earlier stage, the R-Class is available with the optional active light function which improves illumination of the road by up to 90% in bends

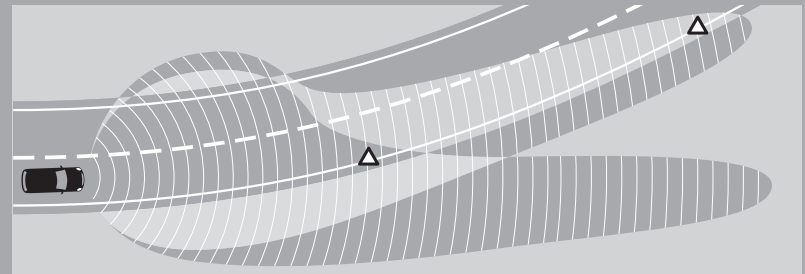



When there's no time to think, the R-Class has already taken the necessary action

The anticipatory PRE-SAFE® system can initiate occupant protection measures as a precaution

The very instant you step on the brake pedal in an emergency, for example, you can be sure the R-Class is already on full alert thanks to its highly advanced sensor systems. This means that, if the emergency develops into an accident, you will be protected earlier and, therefore, even more effectively. After all, a fraction of a second can make all the difference in an emergency.

The standard-fit PRE-SAFE® system works together with a number of systems, including the sensors of the Electronic Stability Program ESP® and Brake Assist (BAS). If these identify a critical situation, the driver and front passenger seat belts are tensioned instantly, the front passenger seat is adjusted to a more favourable position for accident conditions (only in conjunction with the optional Memory package), and if a certain lateral acceleration threshold is exceeded the panoramic sliding sunroof is closed. Once the danger has passed, the belt tensioning is released. All the other systems can then be returned to the desired positions manually.

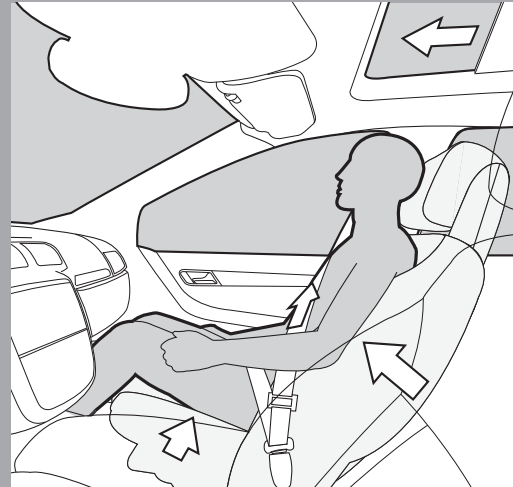

PRE-SAFE® system
Making sure a quick shock has no lasting effects: depending on the driving situation and vehicle specifications, the anticipatory occupant protection system tensions the front seat belts, adjusts the front passenger seat into a more favourable position for accident conditions, and even closes the panoramic sliding sunroof along with the side windows

The passenger compartment

The energy-absorbing front and rear sections as well as the doors with their high-strength reinforcing elements form an effective defensive barrier

Airbags

A great team that responds instantaneously but also knows when to hold back. The front airbags are triggered in a split second in one or two stages depending on the severity of the impact

Front impact structure

Two crash boxes made from high-strength steel absorb much of the impact energy in front-end collisions at speeds up to 15 km/h. As a result, the body structure to the rear remains intact



Our leading players are always there

In the event of an accident, this is where the R-Class shows it has backbone



Side impact structure

High-strength steel, exceptionally strong longitudinal members and triple-layer sidewalls provide protection in a side impact

A high-strength passenger compartment built from high-quality materials and offering long deformation paths provides a reliable protective barrier for the occupants if the worst should happen. But in designing the bodyshell, we also paid particular attention to the question of how to reduce the risk of injury to other road users.

Should a collision nevertheless occur, a sophisticated system of airbags can come to the rescue. The driver and front passenger seats are equipped as standard with front airbags (which deploy

in two stages when the system detects a front impact, depending on accident severity) as well as sidebags. The second seat row can have sidebags integrated into the backrests as an option. In the event of a side collision, or a roll-over, windowbags can expand like a curtain to protect all the seat rows. The driver and front passenger seats, as well as the rear seats, are fitted with 3-point seat belts as standard. Like the front seats, the outer seats in the second row also feature belt tensioners and belt force limiters.

NECK-PRO head restraints

In a rear impact above a given degree of severity, the crash-responsive NECK-PRO head restraints move forwards and upwards to help prevent whiplash. NECK-PRO head restraints are available as standard for the driver and front passenger

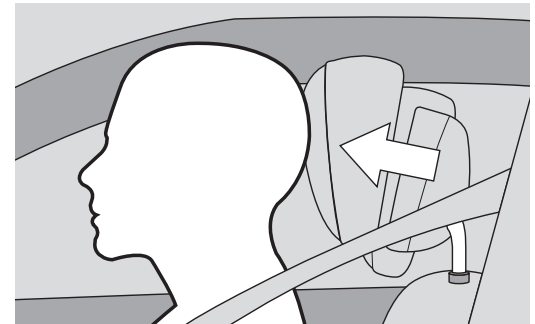





My R-Class





The R-Class: we build it, but you make it what it is

Standard and optional equipment

The versatility of the R-Class is well-matched by the wide range of available appointments. So whatever you plan to do with your R-Class, it will be ideally equipped. The individualisation options start with the vehicle's looks: the interior of the V6 models features matt aluminium trim, with seats upholstered in a combination of Aspen fabric and ARTICO man-made leather. The standard appointments of the R 500 4MATIC include an interior with bird's-eye poplar wood trim and ARTICO man-made leather. All R-Class models feature a twin exhaust system with a chrome tailpipe. Other equipment packages are also available, for example the Exterior Sports package which includes dynamic light-alloy wheels, or the Interior Sports

package with aluminium trim and many other attractive features. Added to which is the AMG Interior Sports package with a host of special highlights. Naturally the list of appointments includes many items designed to enhance practicality and comfort. More thought has been devoted to passenger comfort than in almost any other car. The occupants in the second and third seat rows are particularly well catered for: the range of options extends from a Rear Seat Entertainment package to the Interior Light package (including reading lights for the third seat row and a host of illuminated practical details) and the luxury automatic climate control THERMOTRONIC, to an especially large panoramic sliding sunroof.

More than 40 items with one objective: to make you feel good

The comprehensive standard equipment of the R-Class

A look at the standard equipment provides confirmation of the remarkable skill with which opposites have been reconciled in the R-Class. There is a transmission which made its debut in the world of motorsport, an automatic climate control system and a multifunction steering wheel that simplifies a multitude of tasks (including operating the Audio 20 CD radio), as well as a

comfortable 3-seater bench for passengers in the rear. The interior flexibility of the R-Class also puts many a rival in the shade, not to mention the extensive safety systems included as standard – such as the crash-responsive NECK-PRO head restraints. In short, the R-Class offers everything you need for a pleasant journey.

THERMATIC automatic climate control



Multifunction steering wheel in nappa leather



Audio 20 CD radio



STANDARD EQUIPMENT (SELECTION)

18-inch light-alloy wheels for the V6 models (17-inch for the R 300 CDI BlueEFFICIENCY), 19-inch for the R 500 4MATIC

4MATIC permanent all-wheel drive for R 350 CDI, R 350 BlueTEC and R 500

5-seater with 4 executive chairs (semi-electrically adjustable in the front) and a centre seat

7G-TRONIC automatic transmission

Airbags with multi-stage deployment logic and sidebags for driver and front passenger, plus windowbags for all seat rows

Anti-lock braking system ABS

ASSYST PLUS service interval indicator with service computer

Audio 20 CD radio with MP3 function, telephone keypad, 8 loudspeakers, Bluetooth® interface

Aux-in connection in the glove compartment

Brake Assist (BAS)

Combination of Aspen fabric/ARTICO man-made leather upholstery

Cruise control with SPEEDTRONIC

Cup holders in the front (2)

Diesel particulate filter in R 300 CDI BlueEFFICIENCY, R 300 CDI 4MATIC, R 350 CDI 4MATIC and R 350 BlueTEC 4MATIC

DIRECT SELECT steering-wheel gearshift buttons with selector lever

Direct-Steer system

Electronic immobiliser incl. locking system with radio/infrared remote control (recognised by AZT (Allianz Technology Centre) and German Technical Inspection Authority)

ESP®/4ETS (Electronic Stability Program and Electronic Traction System) with ESP® trailer stabilisation

Exit lights and reflectors (4), additional reflector in tailgate

Five head restraints, manually adjustable for all seats

Folding front armrest (between driver's seat and front passenger seat) with phone compartment and stowage compartment

Front fog lamps with chrome surround and rear fog lamp

Headlamp Assist

Heated exterior mirrors, electrically adjustable from inside, finished in vehicle colour, with aspherically curved mirror glass and integral indicator lamp

Hill-Start Assist

ISOFIX child-seat attachment points for outer seats of second seat row

Leather multifunction steering wheel

Load-securing rings (8)

NECK-PRO head restraints for driver and front passenger

Outside temperature display

Power windows (4)

Pre-installation for roof carrier systems

PRE-SAFE® system

Rear apron with optical scratch protection

Seat occupancy sensor in front passenger seat

Steel suspension (for R 500 4MATIC: rear air suspension with level control)

Steering column manually adjustable for height and reach

Stowage space in the load compartment floor (51 litres), exclusively in the 5-seater

THERMATIC automatic climate control with combination filter

Three-point seat belts with adaptive belt force limiters and belt tensioners, centre seat with 3-point seat belt only

Tinted glass all round, rear windscreen in single-layer safety glass

TIREFIT tyre sealant with electric pump

Two-pipe exhaust system with visible oval tailpipes

Tyre pressure loss warning system

Windscreen wipers with one-touch wiper function and rain sensor with infinitely variable intermittent wipe setting



Show your mettle

Light-alloy wheels for every taste

There are many ways of getting the R-Class up to speed: the range extends from 17-inch light-alloy wheels to special AMG-designed 21-inch light-alloy wheels painted in titanium silver – this is the largest wheel size available from the Mercedes-Benz wheel range. Other wheels are available from our accessories range.

Optional part of the Exterior Sports package: the 19-inch 5-spoke light-alloy wheel, size 255/50 R 19



Standard equipment for R 300 CDI BlueEFFICIENCY and R 350 BlueTEC 4MATIC: 17-inch 7-spoke light-alloy wheel, size 235/65 R 17



Standard equipment for the V6 models, not for the R 300 CDI BlueEFFICIENCY and R 350 BlueTEC 4MATIC: 18-inch 5-twin-spoke light-alloy wheel, size 255/55 R 18



Standard equipment for the R 500 4MATIC: 19-inch 5-spoke light-alloy wheel, painted in sterling silver, size 255/50 R 19



Optional: 18-inch 10-spoke light-alloy wheel, size 255/55 R 18



Optional: 20-inch 5-spoke AMG light-alloy wheel, high-sheen finish, size 265/45 R 20



Optional: 21-inch 5-spoke AMG light-alloy wheel, painted in titanium silver, size 265/40 R 21

Where extras play a starring role

incenio light-alloy wheels from our range of genuine accessories

It is often the carefully crafted details that make the difference: take the incenio light-alloy wheels from our range of genuine accessories, for instance. The incenio “Angetenar” 18-inch light-alloy wheel for tyre size 255/55 R 18

features six spokes and a high-sheen titanium silver finish. Another particularly elegant example is the incenio “Sadalmelik” 19-inch 5-spoke designer wheel painted in sterling silver and available in size 255/50 R 19 and 285/45 R 19

for the rear axle. And if you like your details a little larger, consider the “Alanz” 20-inch wheel with its 5-twin-spoke design. Wearing 265/45 R 20 tyres, it gives the R-Class a particularly powerful presence.



The incenio “Angetenar” 18-inch light-alloy wheel with high-sheen finish, size 255/55 R 18



The incenio “Sadalmelik” 19-inch light-alloy wheel painted in sterling silver, size 255/50 R 19 and 285/45 R 19 for the rear axle

The incenio "Alanz" 20-inch light-alloy wheel, size 265/45 R 20



The sky's the limit

From the Rear Seat Entertainment package to the panoramic sliding sunroof

Given the formidable exterior dimensions of the R-Class it is hardly surprising there is lots of room for a host of extras. You can emphasise your sporty side with one of the Sports packages or with special light-alloy wheels. Other convenient options include a reversing camera (in conjunction with COMAND APS multimedia system), which makes parking much easier. And on a practical note, there is a rear centre console for the 4+2-seater, the EASY-PACK tailgate and various ideas for keeping the luggage compartment tidy. And on-road entertainment is also catered for: customers can choose from radios with a CD drive or

DVD changer as well as a TV tuner, which is available in conjunction with COMAND APS and the Rear Seat Entertainment package. This equipment line-up enables you to convert the R-Class into a cinema or a concert hall on wheels. As an option, you can even create an open-air feel – courtesy of a sliding sunroof or the extra-large panoramic sliding sunroof (pictured on the right). Extending over virtually the entire roof area, it is far bigger than conventional sliding sunroofs and floods the spacious interior with light.





The panoramic sliding sunroof
Admits more light than
most sliding sunroofs

COMAND APS with its clearly legible 6.5-inch colour display





COMAND APS allows you to look up phone numbers and make calls



The reversing camera makes manoeuvring into spaces easier by showing the area to the rear of the vehicle on the COMAND display



Acoustic perfection: the control interface for the Harman Kardon® Logic 7® surround sound system

COMAND APS: intelligence meets entertainment

Your information, navigation and audio centre

Navigation, audio system and telephone functions aboard the R-Class can be combined in one user-friendly interface with the COMAND APS control and display system. Whether you want to listen to the radio, dial a phone number, play a CD or be guided to your destination quickly and easily – everything comes together in COMAND APS.

COMAND APS features a 6.5-inch colour display, a DVD changer (for audio/video), 4-GB storage space for MP3 files (MUSIC REGISTER) and a hard-disc navigation system with an extremely high storage capacity. A colour map display indicates the route. A compass function in the display is also part of COMAND APS. The ultimate operating convenience is provided by the integrated voice-control system LINGUATRONIC with audio, telephone and navigation functions. A Bluetooth® interface with a hands-free function is also included as standard.

Once you have reached your destination, another optional feature can help you with parking. The reversing camera provides you with visible and audible warnings of obstacles. When you are reversing, the COMAND display shows you the area behind the R-Class. Housed in the tailgate handle, the camera is activated when reverse gear is selected.

All Mercedes-Benz radios are equipped with a speed-sensitive volume control system which increases the sound level progressively at speeds above 20 km/h.

The most demanding music fans will settle for nothing less than the Harman Kardon® Logic 7® 5.1 surround sound system with eleven loudspeakers (instead of the standard eight) and a subwoofer. This 610-watt system is tuned so precisely to the R-Class that neither the speed of the vehicle nor external noise can compromise its acoustic quality.

A world of entertainment in the rear

Extras that make short work of long trips

While the driver enjoys the superb driving experience offered by the R-Class, the second-row passengers can sit back in comfort and enjoy movies on the move. All that is required is the optional Rear Seat Entertainment package available for all seating variants, which comprises a CD/DVD player, 8-inch screens mounted on the head restraints, two sets of wireless headphones and a remote control unit. A TV tuner is also available as an option (in conjunction with the COMAND APS multimedia system and the Rear Seat Entertainment package), and a games console can be connected to each screen.

As in all the best cinemas, there are two optional cup holders in the rear as well as ample stowage facilities – perhaps for the popcorn. These features

are part of the optional rear centre console, whose damped-hinge cover doubles as an armrest. The compartment inside offers seven litres of stowage space. The rear centre console is removable (available for the 4+2-seater).

Whether you're watching an action film set in the Sahara or a documentary about the Arctic, the optional multi-zone luxury automatic climate control THERMOTRONIC will make sure that the temperature on board is always just right. This system allows three temperature zones – for the driver, front passenger and rear section – to be controlled independently. The occupants of the second row of seats have access to duplicate controls for the rear temperature zone.

Multi-zone THERMOTRONIC

So as to provide the desired temperature at all times for such a large space, the luxury automatic climate control system works in conjunction with nine sensors dispersed around the entire interior

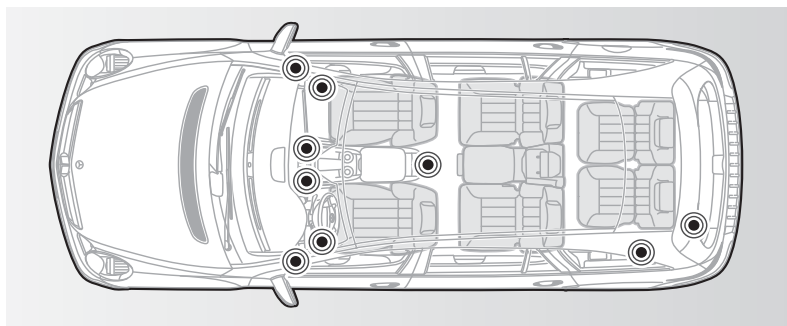

Rear Seat Entertainment package



Multi-zone THERMOTRONIC



Rear centre console



The sports seats (included in the Interior Sports package) provide particularly good lateral support



Hidden inside the multicontour seats, air cushions provide optimum back support for extra comfort



Sitting – in truth, only lying down is more relaxing

Sports or multicontour seats: comfortably the best

The seats in the R-Class are designed to deliver you to your destination as refreshed and relaxed as you were at the start of the journey. That may sound like a tall order, but the “executive chair” seating fitted in the first and second rows (in the 5-seater, the two outer seats in the second row) offers a very high level of comfort. For the ultimate in seating luxury, you can choose heated and ventilated front seats. Or the multicontour seats which are available as an optional extra for the driver and front passenger. These seats are equipped with inflatable air chambers which adjust to your body and provide better support.

If you would like improved lateral support – especially during cornering – you can opt for front sports seats with higher side bolsters on the backrests. These seats are electrically adjustable and are upholstered in Alcantara®/ARTICO man-made leather (as part of the Interior Sports package). If you opt for the AMG Interior Sports package, the specification also includes AMG sports seats in high-quality nappa leather.

The Memory package is another practical optional extra. As well as offering full power adjustment for the front seats, the system can store the positions of the driver’s seat, head restraint, exterior mirrors and steering column for up to three people.

Seat adjustment

The Memory package (including 4-way lumbar support) stores the settings for the driver’s seat, steering column and exterior mirrors as well as exterior mirrors with automatic adjustment for parking and electrically adjustable front passenger seat



KEYLESS-GO



Wood/leather multifunction steering wheel



Bi-xenon headlamps with active light function



Audio 50 APS radio



<i>OPTIONAL EXTRAS (SELECTION)</i>	R 300 CDI BlueEFFICIENCY	R 300 CDI 4MATIC	R 350 CDI 4MATIC	R 350 BlueTEC 4MATIC	R 300	R 350	R 350 4MATIC	R 500 4MATIC
18-inch 10-spoke light-alloy wheels	●	●	●	●	●	●	●	–
20-inch 5-spoke AMG light-alloy wheels	●	●	●	●	●	●	●	●
21-inch 5-spoke AMG light-alloy wheels	–	●	●	●	–	–	●	●
Additional rear centre console for second row of seats (only available for 4+2-seater)	●	●	●	●	●	●	●	●
AIRMATIC package comprising: Adaptive Damping System (ADS) and all-round air suspension with level control	●	●	●	●	●	●	●	●
AMG Interior Sports package	●	●	●	●	●	●	●	●
Anti-Theft Protection package with towaway protection	●	●	●	●	●	●	●	●
Anthracite poplar wood trim	●	●	●	●	●	●	●	●
ARTICO man-made leather, including electrically adjustable front seats	●	●	●	●	●	●	●	□
Audio 20 CD radio with integrated 6-disc CD changer	●	●	●	●	●	●	●	●
Audio 50 APS radio, incl. DVD navigation, DVD changer and colour display	●	●	●	●	●	●	●	●
Automatic child seat recognition in passenger seat, for Mercedes-Benz-approved child seats with transponder	●	●	●	●	●	●	●	●
Automatically dimming interior and exterior mirrors	●	●	●	●	●	●	●	□
Bi-xenon headlamps with active light function, headlamp cleaning system, dynamic headlamp range adjustment and cornering light function with fog lamp function	●	●	●	●	●	●	●	●
Bird's-eye poplar wood trim	●	●	●	●	●	●	●	□
Burr walnut wood trim	●	●	●	●	●	●	●	●
Chrome package	●	●	●	●	●	●	●	●
COMAND APS multimedia system with hard-disc navigation system and DVD changer	●	●	●	●	●	●	●	●
Crash-responsive exit aid (only in combination with Memory package)	●	●	●	●	●	●	●	●
DISTRONIC proximity control	●	●	●	●	●	●	●	●

● Optional extra

□ Standard equipment

– Not available

<i>OPTIONAL EXTRAS (SELECTION)</i>	R 300 CDI BlueEFFICIENCY	R 300 CDI 4MATIC	R 350 CDI 4MATIC	R 350 BlueTEC 4MATIC	R 300	R 350	R 350 4MATIC	R 500 4MATIC
Memory package for driver's seat, exterior mirrors, steering column, in combination with electrically adjustable front seats	●	●	●	●	●	●	●	●
Metallic paint finish	●	●	●	●	●	●	●	●
PARKTRONIC	●	●	●	●	●	●	●	●
Pre-installation for mobile phone, with universal interface	●	●	●	●	●	●	●	●
Rear air conditioning (only in combination with THERMOTRONIC)	●	●	●	●	●	●	●	●
Rear Seat Entertainment package with CD/DVD player integrated in rear centre console, display integrated in the back of each of the front-seat head restraints, two sets of wireless headphones	●	●	●	●	●	●	●	●
Reversing camera	●	●	●	●	●	●	●	●
Roller sunblinds in rear doors and sunshade for third row of seats	●	●	●	●	●	●	●	●
Sidebags for second row of seats	●	●	●	●	●	●	●	●
THERMOTRONIC luxury automatic climate control (also for rear)	●	●	●	●	●	●	●	●
TV tuner, for analogue and digital reception	●	●	●	●	●	●	●	●

● Optional extra □ Standard equipment - Not available

Panoramic sliding sunroof



EASY-PACK tailgate – makes loading easier



Sunblind





For a particularly powerful presence

Always immaculately turned out with the Chrome package

Already benefiting from many attractive design elements in its standard specification, the R-Class can be enhanced even further by means of the Chrome package with the following exterior features: vehicle-coloured door handles and side rub strips with chrome inserts. The window frames and shoulderline trim strips are embellished with high-gloss aluminium highlights.



The door handles are finished in the vehicle colour and have a chrome insert

Exterior features of the Chrome package with chrome and aluminium highlights

Symbols of sporting achievement: chrome and silver

The Sports packages for the exterior and interior

The R-Class with Exterior Sports package is easily recognisable thanks to its 19-inch light-alloy sports wheels, rear light units in dark red/grey, and also blue-tinted glass. It also includes all of the elements from the Chrome package.



Rear light units
in dark red/grey

The Exterior Sports package
with powerful 19-inch
light-alloy sports wheels



The Interior Sports package includes a sports steering wheel and sports seats upholstered in Alcantara® / ARTICO man-made leather



The upholstery with contrasting stitching is complemented by the aluminium highlights on the door trim strips



The high-gloss, carbon-look centre console



Striking features of the Interior Sports package include matt aluminium highlights on the door trim strips and dashboard which complement the high-gloss, black carbon-look finish of the dashboard console and centre console as well as the silver-painted instrument cluster. Sports pedals and the Interior Light package are also included.

An appropriately dynamic touch is added to the driving experience by the electrically adjustable front sports seats which offer optimised lateral support and are upholstered in Alcantara®/ARTICO man-made leather with contrasting stitching.

The optional AMG Interior Sports package also includes a number of other exciting features. Alongside the specification for the above Interior Sports package, it comes with AMG sports seats in nappa leather (with no contrasting stitching), the AMG sports steering wheel with black plastic buttons and AMG floor mats.

Hallmarks of the Interior Sports package: silver, aluminium and ARTICO man-made leather



The art of using contrasts to create harmony

The two-tone interior design of the R-Class

We developed the two-tone interior design for customers who wish to give their R-Class a very personal touch. The full effect of this interior, which is characterised by contrasting light and dark areas, only becomes apparent at second glance. A finely balanced combination of colours and materials creates a particularly harmonious yet extremely sporty interior atmosphere.

If this option is specified, the roof liner is in elegant black, while a light-coloured band colour-coordinated with the seats extends along the interior door panels and into the luggage compartment. The carpets in the footwells are in a contrasting, darker colour. In this way the entire interior is framed in black, further accentuating the elegant overall impression. The interior appointments are made from fine leather and are available in a combination of black/cashmere beige or black/alpaca grey.







Here are some more useful items...

Genuine accessories from Mercedes-Benz

A roof spoiler is available for an even sportier touch, for example. And if you need more stowage space, we can recommend the XL roof box with its impressive 450-litre capacity. Left-side or right-side opening versions are available in the colours titanium metallic or matt silver.

Add the optional ski-holder insert and you can securely stow up to five pairs of skis in the XL roof box. And there are two practical ways of taking bicycles with you, either with the New Alustyle roof-mounted bicycle rack or the rear-mounted New Alustyle carrier, which is quickly and easily attached to the trailer coupling. Both versions are able to accommodate up to three bicycles.

An iPod® Interface Kit is also available for the R-Class, designed to incorporate the miniature jukebox elegantly into the audio system. The iPod® is connected to the system inside the glove compartment, where it is hidden from prying eyes. While on the move you can conveniently select music tracks using the multifunction steering wheel. To find out more about the extensive range of options, have a look at our separately obtainable accessories brochure.



Very practical: the rear-mounted New Alustyle bicycle carrier is attached to the trailer coupling. A simple fold-down mechanism ensures that you still have access to the luggage compartment when needed



Even more stowage space: the XL roof box will accommodate five pairs of skis or up to 450 litres of luggage



For enhanced aerodynamics: the roof spoiler

NON-METALLIC PAINTS



040 black

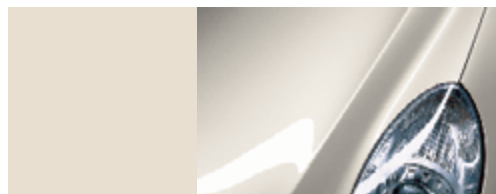

650 calcite white

METALLIC PAINTS¹

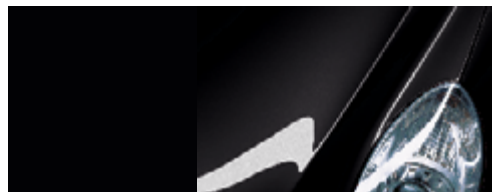

112 chromite black

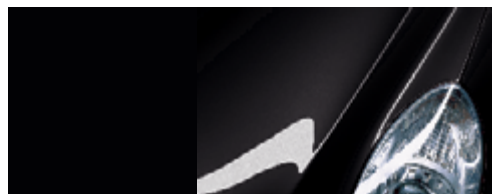

197 obsidian black



359 tanzanite blue



544 carneol red



755 tenorite grey

METALLIC PAINTS¹

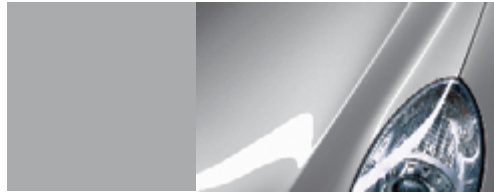

775 iridium silver

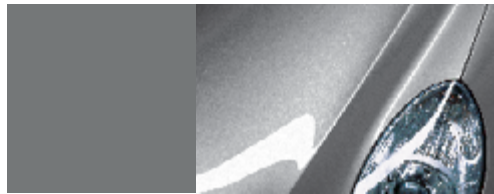

792 palladium silver



798 sanidine beige

SPECIAL PAINT¹



349 lazurite blue

¹Optional extra

ASPEN FABRIC/
ARTICO MAN-MADE LEATHER¹

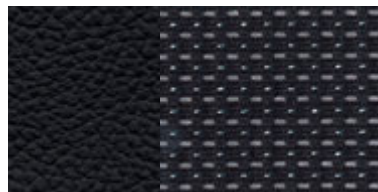

001 black

ARTICO MAN-MADE LEATHER²

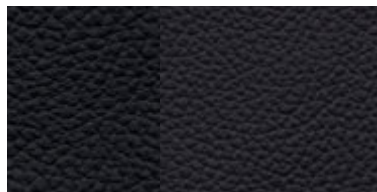

141 black

ALCANTARA®/ARTICO MAN-MADE
LEATHER (INTERIOR SPORTS PACKAGE)

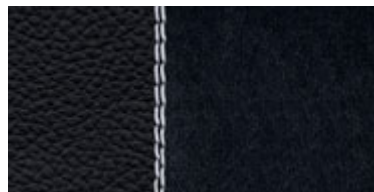

901 black

LEATHER

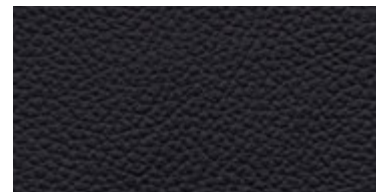

201 black



148 alpaca grey



908 alpaca grey

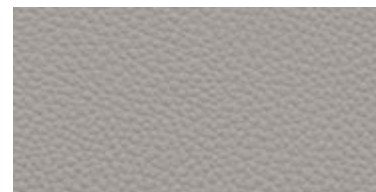

208 alpaca grey

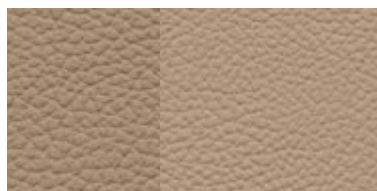

144 cashmere beige

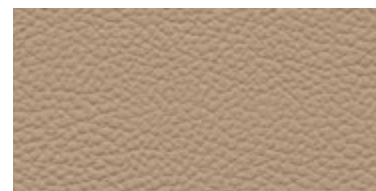

204 cashmere beige

NAPPA LEATHER³



501 black

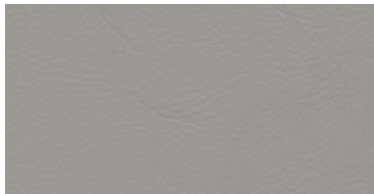

508 alpaca grey



504 cashmere beige

LEATHER,
TWO-TONE INTERIOR DESIGN⁴



258 black / alpaca grey

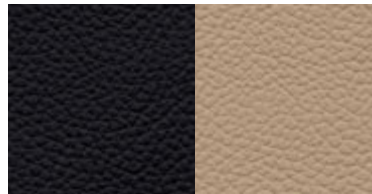

254 black / cashmere beige

With the R-Class, you can always be sure of perfect attire – regardless of whether you opt for fabric, ARTICO man-made leather, fine leather or even finer nappa leather. Incidentally, we have the materials analysed in detail by our haptics researchers in Sindelfingen to ensure that the surfaces have an exceptionally good feel. Whichever

appointments you prefer, the colour chart has been specially matched to the fine woods and sporty aluminium trim elements. The light interior appointments in grey or beige, for example, come with a slightly darker and more resistant carpet for the footwells.

¹ Standard for V6 models

² Standard for R 500 4MATIC

³ Available in conjunction with AMG Interior Sports package (option)

⁴ Recommended with anthracite poplar wood trim



We've developed highly advanced materials for the R-Class. But the most attractive ones still come from our oldest supplier

Exceptionally fine wood elements for an exceptionally fine car

Natural wood elements make every R-Class an exclusive one-off because no two pieces of trim are identical. Nevertheless, the different types of wood we use do have one thing in common: they have all been selected with the greatest care by experts who have scoured the world in search of materials of the very highest quality. Our burr walnut, for example, is imported from California. Before the wood is ready to be fitted, our specialists subject it to a whole series of elaborate processes from which it emerges as a perfectly finished R-Class component.

Bird's-eye poplar wood trim is standard in the R 500 4MATIC, and available as an option for the V6 models. The R-Class can also be enhanced with anthracite poplar or burr walnut highlights. Aluminium trim elements are standard in the 6-cylinder models, and are also included in the Interior Sports package.

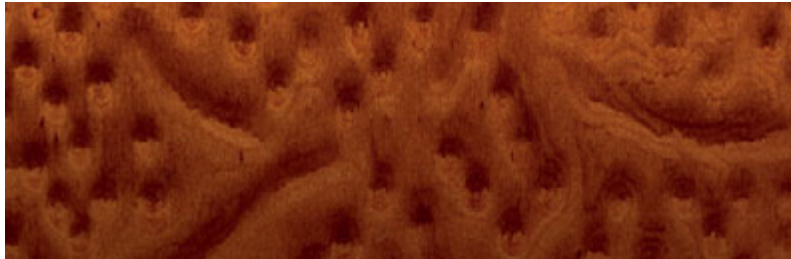

Bird's-eye poplar¹

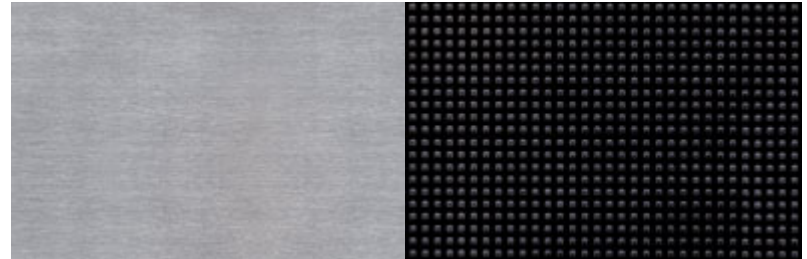

Aluminium trim elements

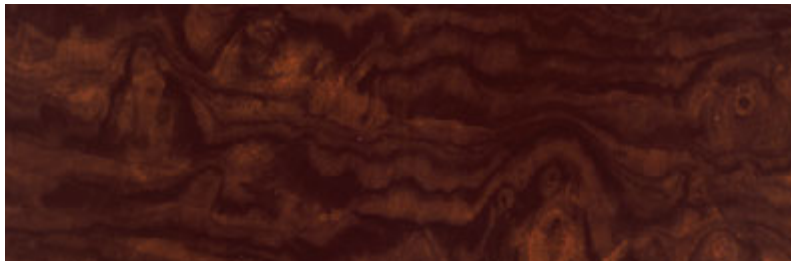

Burr walnut



Anthracite poplar²

¹ Standard in R 500 4MATIC

² Recommended for two-tone interior design

	Aspen fabric/ ARTICO man-made leather ¹ black	ARTICO man-made leather ² black	alpaca grey cashmere beige	Interior Sports package - Alcantara®/ ARTICO man-made leather ³ black	alpaca grey	Leather black	alpaca grey cashmere beige	black/alpaca grey	black/cashmere beige	Nappa leather ³ black	alpaca grey cashmere beige
NON-METALLIC PAINTS											
black	●	●	●	●	●	●	●	●	●	●	●
calcite white	●	●	○	●	●	●	○	○	○	●	○
METALLIC PAINTS											
chromite black	●	●	●	●	●	●	●	●	●	●	●
obsidian black	●	●	●	●	●	●	●	●	●	●	●
tanzanite blue	●	●	○	●	●	●	○	○	○	●	○
carneol red	●	●	●	●	●	●	●	●	●	●	●
tenorite grey	●	●	○	●	●	●	○	○	○	●	○
iridium silver	●	●	○	●	●	●	○	○	○	●	○
palladium silver	●	●	△	●	●	●	△	○	○	●	△
sanidine beige	●	●	△	●	△	●	△	△	△	●	△
SPECIAL PAINT FINISH											
lazurite blue	●	●	△	●	●	●	△	△	△	●	△

● Recommended ○ Possible △ Not recommended

¹ Standard for V6 models

² Standard for R 500 4MATIC

³ Available in conjunction with AMG Interior Sports package (option)



R 350



BLUETEC

S-OG 4747

	<i>R 300 CDI BlueEFFICIENCY¹</i>	<i>R 300 CDI 4MATIC⁷</i>	<i>R 350 CDI 4MATIC</i>
No. of cylinders/arrangement	6/V	6/V	6/V
Bore/stroke (mm)	83/92	83/92	83/92
Total displacement (cc)	2987	2987	2987
Rated output ² (kW at rpm)	140/4000	140/4000	165/4000 (3800)
Rated torque ² (Nm at rpm)	440/1400-2800	440/1400-2800	540/1600-2800
Compression ratio	17.7	17.7	17.7
Acceleration 0-100 km/h (s) (long-wheelbase version)	9.7 (9.8)	9.8	8.7 (8.8)
Top speed, approx. (km/h)	210	210	222
Tyre size (long-wheelbase version)	235/65 R 17 (255/55 R 18)	255/55 R 18	255/55 R 18
Fuel	Diesel	Diesel	Diesel
Fuel consumption ³ (l/100 km) (long-wheelbase version)			
urban	10.9-11.4 (11.4-11.4)	12.2-12.5	12.2-12.5 (12.2-12.5)
extra-urban	6.7-7.0 (7.0-7.0)	7.6-7.8	7.6-7.8 (7.6-7.8)
combined	8.2-8.6 (8.6-8.6)	9.3-9.5	9.3-9.5 (9.3-9.5)
CO ₂ emissions ³ (g/km) combined (long-wheelbase version)	217-227 (227-227)	246-253	246-253 (246-253)
Tank capacity (l)/incl. approx. reserve	80/13	80/13	80/13
Turning circle diameter (m) (long-wheelbase version)	11.7 (12.4)	11.7	11.7 (12.4)
Max. load capacity ⁴ (l) (long-wheelbase version)	2001 (2436)	2001	2001 (2436)
behind 2 nd row of seats	939 (1118)	939	939 (1118)
behind 3 rd row of seats ⁵	324 (414)	324	324 (414)
Kerb weight ⁶ (kg) (long-wheelbase version)	2185 (2245)	2250	2250 (2295)
Perm. GVW (kg) (long-wheelbase version)	2840 (2880)	2880	2880 (2910)

Figures in brackets apply to the long-wheelbase version

<i>R 350 BlueTEC 4MATIC</i>	<i>R 300</i>	<i>R 350</i>	<i>R 350 4MATIC</i>	<i>R 500 4MATIC</i>
6/V	6/V	6/V	6/V	8/V
83/92	88/82.1	92.9/86	92.9/86	98/90.5
2987	2996	3498	3498	5461
155/3400	170/6000	200/6000	200/6000	285/6000
540/1600–2400	300/2500–5000	350/2400–5000	350/2400–5000	530/2800–4800
16.5	11.3	10.7	10.7	10.7
(8.9)	9.6 (9.7)	8.1 (8.2)	8.3 (8.4)	6.1 (6.3)
216	222	234	230	250 ⁸
(235/65 R 17)	255/55 R 18	255/55 R 18	255/55 R 18	255/50 R 19
Diesel	Premium unleaded	Premium unleaded	Premium unleaded	Premium unleaded
(11.7–11.7) (7.0–7.3) (8.7–8.9)	15.2–15.4 (15.2–15.5) 8.8–9.0 (8.8–9.1) 11.1–11.3 (11.1–11.4)	15.7–15.9 (15.7–15.9) 8.8–9.0 (8.8–9.0) 11.3–11.5 (11.3–11.5)	15.8–16.1 (15.9–16.1) 9.2–9.5 (9.3–9.5) 11.6–11.9 (11.7–11.9)	18.6–18.8 (18.6–18.8) 10.0–10.2 (10.0–10.2) 13.2–13.4 (13.2–13.4)
(229–234)	260–265 (260–267) ⁹	265–270 (265–270) ⁹	271–279 (274–279) ⁹	306–311 (306–311) ⁹
80/13	80/13	80/13	80/13	80/13
(12.4)	11.7 (12.4)	11.7 (12.4)	11.7 (12.4)	11.7 (12.4)
(2385)	2001 (2436)	2001 (2436)	2001 (2436)	2001 (2436)
N/A	939 (1118)	939 (1118)	939 (1118)	939 (1118)
N/A	324 (414)	324 (414)	324 (414)	324 (414)
2335	2130 (2175)	2130 (2175)	2180 (2230)	2220 (2265)
(2910)	2790 (2840)	2790 (2840)	2840 (2880)	2880 (2920)

¹ Short-wheelbase version. Long-wheelbase version available as R 300 CDI

² Figures in accordance with Directive 80/1269/EEC in the currently applicable version

³ The figures shown were obtained in accordance with the prescribed measuring process (Directive 80/1268/EEC in the currently applicable version).

The figures are not based on an individual model and do not constitute part of the product offer; they are provided solely for purposes of comparison between different vehicle models

⁴ Figures for vehicles with TIREFIT, loaded up to roof level

⁵ If specified as a 4+2-seater or 5+2-seater

⁶ Figures according to Directive 92/21/EC, as amended by 95/48/EC (kerb weight with fuel tank 90% full, driver, 68 kg, and luggage, 7 kg) for standard-specification vehicles.

Optional extras and accessories will generally increase this figure and reduce the payload capacity accordingly

⁷ R 300 CDI 4MATIC is not available as long-wheelbase version

⁸ Electronically limited

⁹ Meets requirements of EU5 emission standard

R-Class

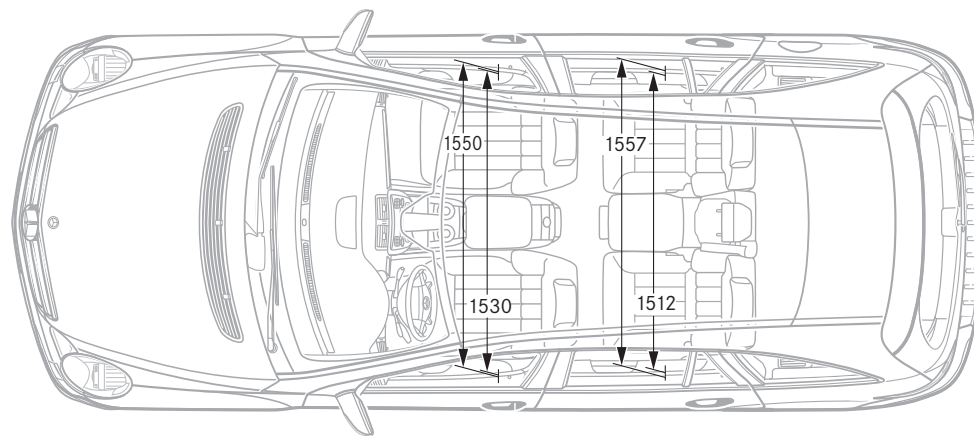
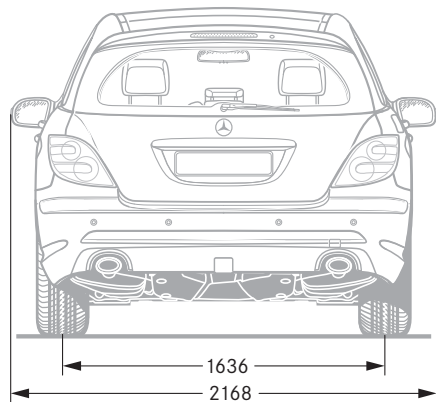
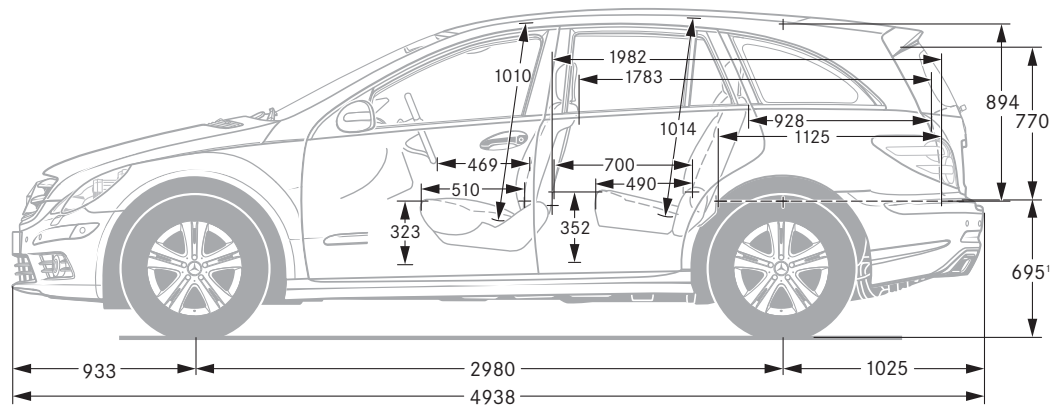
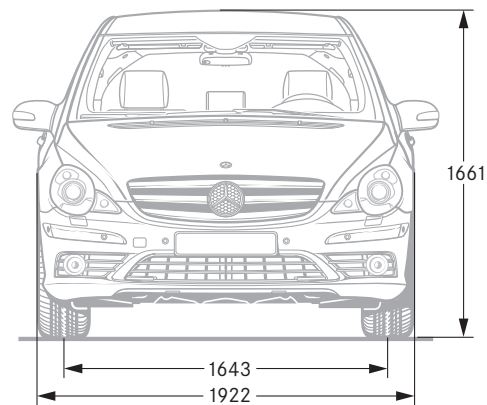

All measurements in millimetres. The dimensions shown are mean values and apply to standard-specification, unladen vehicles

¹ Carrying 4 people, each weighing 68 kg

R-Class: long-wheelbase version

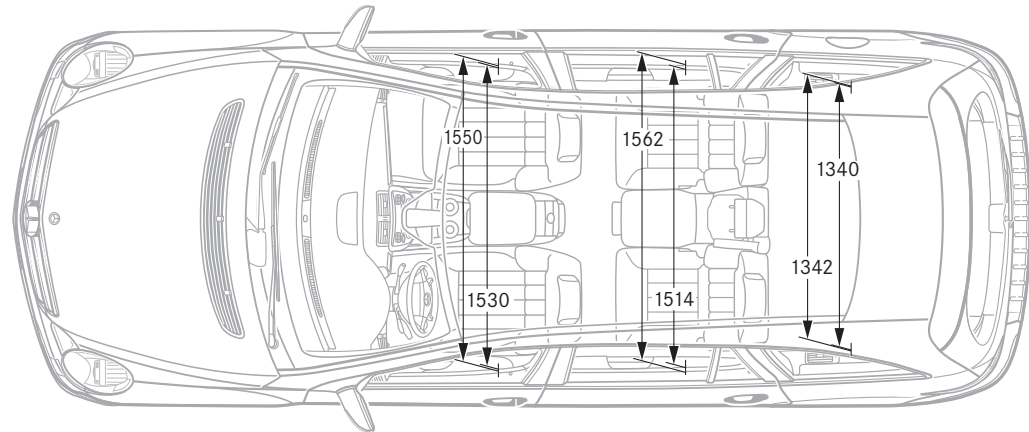
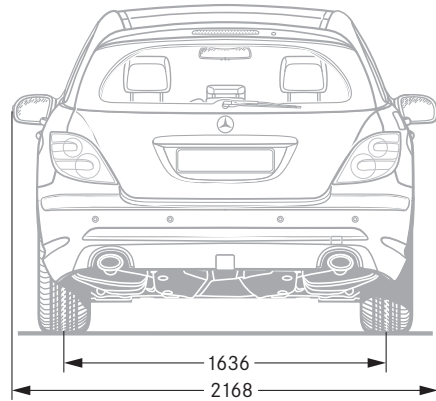
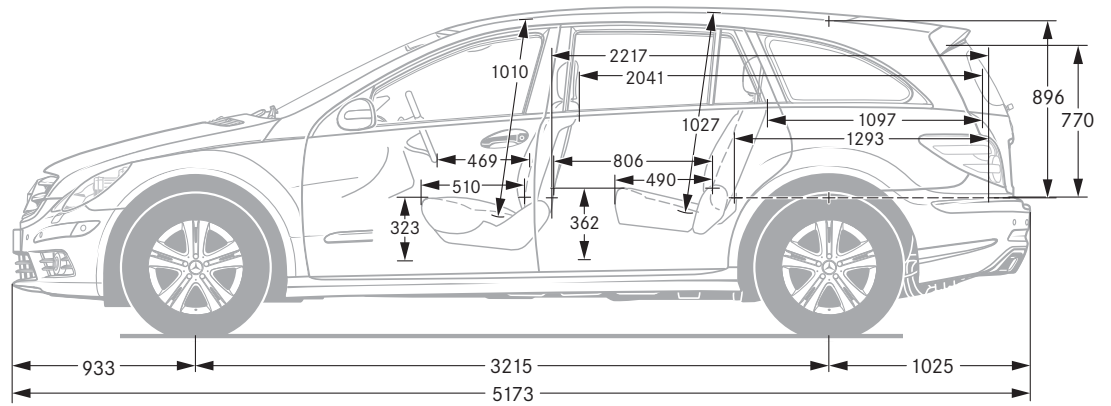
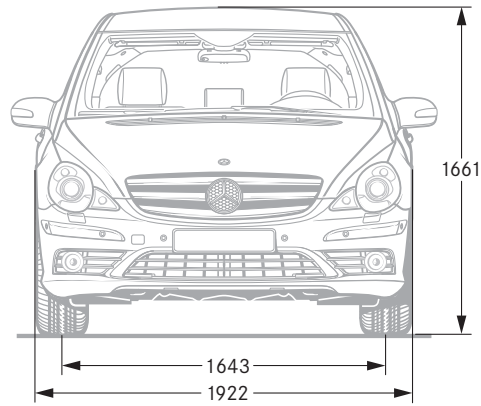

All measurements in millimetres. The dimensions shown are mean values and apply to standard-specification, unladen vehicles

Anyone opting for a Mercedes buys far more than just a car

Comprehensive service offered by Mercedes-Benz

Mercedes-Benz for you. It all started in Berlin at the end of 2000: the concept of the car dealership was reinvented with the opening of the first Mercedes-Benz Center. Featuring the entire Mercedes-Benz model line-up as well as the accessories range, brand merchandise and an attractive programme of events, the Centers offer a welcoming environment in which to experience the brand at first hand. But it's not just in major cities that you can experience the legendary Mercedes-Benz brand and service. A close-knit network of company-owned branches and authorised dealers ensures that you are never far from the wide range of services, the comprehensive customer care and the high quality which you expect from Mercedes-Benz. And you can count on their support at every stage – before you buy your Mercedes, during the purchase process and, most importantly, for a long time afterwards, too.

Mercedes-Benz Museum. More than 120 years of automotive history in one place – this is what awaits you at the Mercedes-Benz Museum in Stuttgart. Experience the unique excitement and embark upon a thrilling journey through time. Housed inside an architecturally impressive building, over 1500 exhibits on nine levels give you an insight into the unique tradition and powers of innovation of the Mercedes-Benz brand. Plus you can see the world's first two automobiles in the shape of the Benz Patent-Motorwagen (motor car) and the Daimler motorised carriage – both from the year 1886. Two linked circuits take you from the beginnings of the automobile, past a series of unforgettable classics, through more than 100 years of motor racing history and, finally, on to a glimpse of what the future holds – all in an area covering a total of 16,500 square meters. Enjoy the unique brand experience. We look forward to your visit. More information is available at www.mercedes-benz.com/museum

MercedesCard. Your ticket to the Mercedes-Benz experience: four times a year we will send you exciting details of a selected range of events and services which we have put together exclusively for you. Then there is the Mercedes Magazine with its fascinating reports and articles. But the MercedesCard also has many other uses: as a VISA credit card, it is an internationally accepted means of payment. Answer the annual questionnaire and we'll even waive the card fee. Plus the card offers further benefits to provide you with peace of mind, such as the Mercedes-Benz insurance package at no extra charge and the exclusively compiled MercedesCard insurance package at a preferential price. You can also gain free entry to the Mercedes-Benz Museum simply by showing your VISA MercedesCard. Further information can be found at www.mercedes-benz.de/mercedescard¹

¹ Information about the MercedesCard in Austria and Switzerland can be found on the Mercedes-Benz websites for these countries

Mercedes-Benz mobility. There will always be a helpful passenger in your new car: the assurance of carefree driving. Should you ever need assistance, however, the Mercedes-Benz Service24h is there for you. Just call the freephone service hotline on 00800 1 777 7777¹. The newly integrated telematics service Mercedes-Benz Contact² is even more customer-friendly: a touch of a button is all it takes to contact the Mercedes-Benz customer centre by phone. And if you wish all the relevant vehicle and position-related data can be sent at the same time, ensuring the fastest possible reaction time and rapid on-the-spot help. As standard and at no extra charge: the Mercedes-Benz mobility package Mobilo³. Whether you have lost your key, have had a breakdown which cannot be repaired immediately or if the vehicle is damaged as a result of an accident or vandalism, Mobilo gets you to your destination – anywhere in Europe. Whatever the nature of your problem, one thing is sure: you will soon be able to resume your journey.

Whether you have lost your key, are having problems starting your car or have had a breakdown which cannot be repaired immediately – Mobilo ensures that you still reach your destination – anywhere in the whole of Europe, even if the vehicle is damaged as a result of an accident or vandalism. Should a repair take a little longer, we will even cover the cost of an overnight stay. But don't get too excited – after all, it's very rare for a Mercedes to break down. Whatever the nature of your problem, one thing is for certain: you will soon be able to resume your journey, satisfied that the problem has been solved.

Mercedes-Benz Bank. If you have already chosen your dream car and want to remain financially flexible, you should make us your next port of call, whether it be for leasing, finance, insurance or service packages. Our “Private Leasing plus” scheme is a complete package comprising leasing, third-party insurance and fully-comprehensive insurance. “Business Leasing plus” for business customers works in much the same way, while our “Plus3 Financing” combines the low repayment rates of a financing scheme with the flexibility of leasing. You then have three options at the end of the contract: you can keep the car, sell it or return it to us for a guaranteed price and switch to a new model. We can also offer a range of investment products such as fixed-interest products, savings plans, investment funds or depository receipts. For details, please call 01803/32 22 65⁴ or visit www.mercedes-benz-bank.de

¹ Mobile phone rates vary according to service provider

² Requires factory-fitted radio and a switched-on mobile phone. The only charge incurred is the cost of the mobile phone call to the landline network

³ When the warranty has expired Mobilo can be extended by another year for a maximum of 30 years, provided that regular maintenance is carried out by your Mercedes-Benz service partner

⁴ 9 ct./min from Deutsche Telekom landlines, mobile-phone rates may vary

Time for another enriching experience

A Mercedes-Benz is most at home on the road. This is the only way to experience the effortlessly superior driving feel that lends every Mercedes model its inimitable class. Feel the power of efficient engines with low fuel consumption and precise steering, designed to put you right in the mood for driving. And experience what true comfort really is. The unique feeling of driving a Mercedes cannot be put into words, however. Which is precisely why we'd like to invite you to take a test drive. Your Mercedes-Benz dealer will be happy to make all the necessary arrangements for you. Simply visit www.mercedes-benz.com to locate the nearest Mercedes-Benz dealer in your country or region. We look forward to seeing you.

The website also offers an interactive tour, enabling you to take a closer look at your desired model. This simulation is the ideal way to acquaint yourself with your dream car. You can view key functions in detail, gain an insight into the car's inner workings or look at the benefits of each model. For further details, visit www.mercedes-benz.de/owners-manual

Now your mobile phone acts as a gateway to the whole Mercedes-Benz world. In addition to an overview of all passenger car models, there are insights into the entire brand world, not to mention a wealth of entertainment offers and direct links to a range of services at www.mercedes.mobi

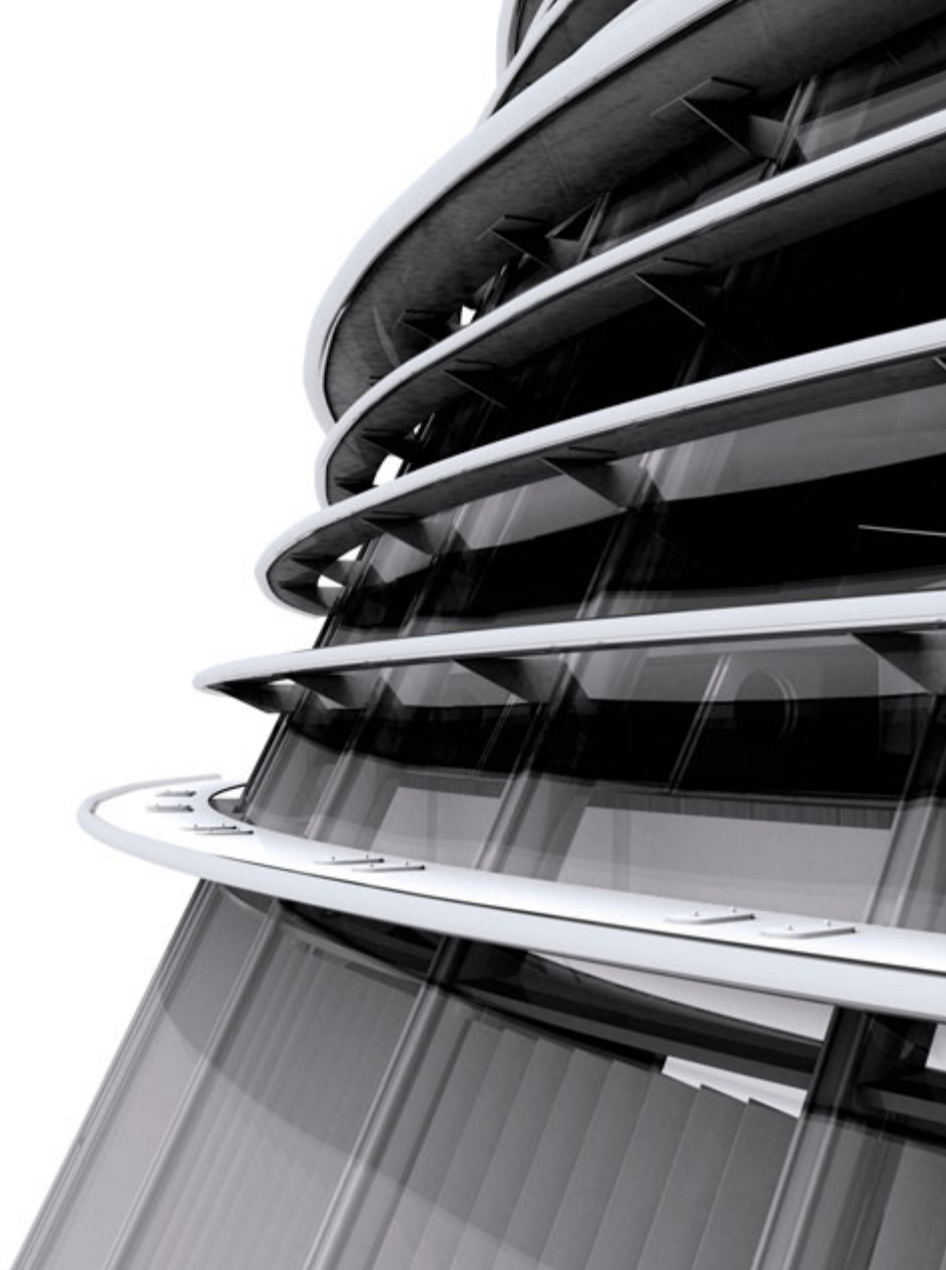

Tras una larga vida útil, nos hacemos cargo de su vehículo para proceder a su eliminación de forma ecológica, en conformidad con la directiva de la UE sobre el reciclaje de vehículos al final de su vida útil. Pero no se preocupe: aún han de pasar muchos años hasta que llegue ese momento. Esta directiva es válida en conformidad con la legislación nacional para vehículos cuyo peso máximo autorizado es de hasta 3.5 T. El diseño de su vehículo cumple, desde hace ya años, con los requisitos legales de reciclaje. Existe una red de centros autorizados de recepción/tratamiento de vehículos para su reciclado, disponible para la recepción de su vehículo al final de su vida útil, en los que su vehículo puede ser reciclado con un mínimo impacto ambiental. Seguimos desarrollando y mejorando la posibilidad de reciclado tanto del vehículo como de sus componentes, por lo que su vehículo cumplirá en todo momento con los cada vez más elevados porcentajes legales de reciclado.

Si desea más información al respecto, llame al 00800 1 777 7777 o consulte nuestra página web.

En relación a los datos contenidos en este catálogo, pueden producirse cambios tras el cierre de redacción (04/09/2009). El fabricante se reserva el derecho de efectuar modificaciones en el diseño, la forma, el color o el equipamiento durante el plazo que media entre el pedido y la entrega, siempre y cuando dichas modificaciones o divergencias sean razonablemente aceptables para el comprador y no exista detrimento de los intereses del vendedor. La circunstancia de que el vendedor o el fabricante utilicen códigos especiales para identificar el pedido o el objeto solicitado no supondrá en ningún caso el reconocimiento de derecho alguno sobre éste. Las ilustraciones muestran, también, equipos opcionales y accesorios no pertenecientes al equipamiento de serie. Posibles diferencias entre la pintura original y el color reproducido se deben a la técnica de impresión. Esta publicación puede contener modelos, equipamientos y servicios no disponibles en determinados países. Las informaciones contenidas en este catálogo referentes a prescripciones legales y fiscales y sus efectos son válidas únicamente en España para vehículos con placa nacional. Se recomienda que, para obtener datos más actualizados, se dirija a su Concesionario Oficial Mercedes-Benz. www.mercedes-benz.es