



This brochure has been compiled by Daimler AG of Germany and is distributed internationally. It provides a general indication of the range of models, features, optional extras and/or colours available in various countries. Some of the models, features, optional extras and/or colours shown may not be available in your country or may only be available in a different specification. Additionally some models, features, optional extras and/or colours may only be available in combination with others. For current and more specific information in relation to the range of models, features, optional extras and/or colours available in your country, and their pricing, you should contact your authorised Mercedes-Benz Passenger Car Dealer.

Mercedes-Benz



THE R-CLASS



Mercedes-Benz

“Our philosophy is very simple.
We give our best for people who expect the best.”

Dr Dieter Zetsche

The R-Class

COMFORT	14
Design	16
Cockpit	18
5 seats	20
Seating variants	28
Long-wheelbase version	32
<hr/>	
AGILITY	34
Diesel engines	36
Petrol engines	38
Transmission	40
Drive system and chassis	42
<hr/>	
SAFETY - PRO-SAFE™	46
Safe driving	48
In the event of danger	50
In an accident	52

My R-Class

EQUIPMENT	54
Standard equipment	58
Light-alloy wheels	60
Optional extras	64
Chrome package	76
Sports packages	78
Two-tone interior design	82
<hr/>	
GENUINE ACCESSORIES	84
<hr/>	
COLOURS AND MATERIALS	86
Paint finishes	88
Upholstery and leather	90
Wood and trim elements	92
Possible combinations	94
<hr/>	
TECHNICAL	
Technical data	96
Dimensions	98
<hr/>	
SERVICES	100

The new form of space travel

The R-Class – more independence

The unending vastness of the sea, a cloudless sky or unspoiled landscapes – space has always been the best form of relaxation and rest. One good example is the R-Class, the SUV Tourer from Mercedes-Benz. Thanks to its generous and variable interior, it not only ensures an unrivalled atmosphere, but also impressive long-distance comfort.

In standard trim the SUV Tourer is a 5-seater with three seats in the second row, however it is also optionally available with six or seven seats. In the 5-seater there is a multi-use luggage compartment which offers an unbeatable capacity of 2436 litres in the long version.

In addition to generous interior space, the R-Class provides outstanding flexibility, two different wheelbases, rear-wheel or 4MATIC four-wheel drive, new engine variants and a new, more striking appearance with particu-

larly sporty styling and 18-inch light-alloy wheels (19-inch for R 500 4MATIC). Accordingly the R-Class not only makes its mark through its appearance, but also with 13 different basic versions which offer you numerous choices. Other new features include an optional two-tone interior design, luxurious materials and technical highlights to make driving even more enjoyable.

A range of smooth, powerful engines ensures an effortless, carefree driving experience: two diesels and three petrol powerplants are available. If even more traction is required, you can opt for the 4MATIC all-wheel drive system. Additional safety is ensured by the optional PRE-SAFE® anticipatory occupant protection system.

Wherever you are going – the R-Class is a vehicle for people who enjoy life while wanting to retain their independence.





















The feel-good class

Discover a new dimension of comfort

Leather, wood, chrome and even air – there are many reasons why the R-Class creates a sense of well-being in its occupants which few other cars can rival. Take the standard steel suspension, for example. Even when the vehicle is fully laden, it provides a particularly comfortable ride. The R 500 4MATIC and the 5+2-seater are even equipped with a rear air suspension including level control. Specify the optional AIRMATIC package, consisting of all-round air suspension and the Adaptive Damping System (ADS), and you'll feel as if you really are riding on air.

In the interior the driver and front passenger will find luxurious “executive chairs” awaiting them. Behind them is where all the versatility starts. The R-Class comes in a 5-seater variant as standard, featuring a 3-seater rear bench and a large flap recessed into the floor of the luggage compartment. On request it is also available as a 6-seater or 7-seater. In the 4+2 and 5+2-seater versions, an extra row of seats replaces the luggage compartment flap. Other options ensure the ultimate listening pleasure for your passengers: you can compile your own programmes with the rear entertainment system. At the same time just the right interior temperature can be selected with the optional multi-zone THERMOTRONIC automatic climate control system, which has a separate air conditioner for the rear.

Whatever your destination – the R-Class makes every journey worthwhile.



The next best thing to taut lines? Flowing curves

The interior: a gripping narrative that will always engage your interest

The sense of power generated by the R-Class is immediately apparent inside the vehicle, too. Our designers have created a compelling interplay of convex and concave forms, edges and curves, light and shadow. Tautness and fluidity alternate and fill the interior with life. The design team's inspiration for the cockpit – a “horizontal muscular structure” – is reflected in the curved forms of the dashboard, door panels and tunnel cover elements.

As they developed the interior, the R-Class design team worked on the basis that “something that looks good has to feel good, too”. Tangible evidence of their commitment to this principle is provided by the switches and knobs with their “soft-feel” coating as well as by the soft armrests or the aluminium and fine wood trim elements. The result is a harmoniously balanced interior which is as pleasing to the touch as it is to the eye.

The two-tone interior design in black / alpaca grey is optionally available.



We bend over backwards to make sure that you don't have to

Intelligent technology optimises the ergonomics of the R-Class

Although we would be the first to admit that the sense of well-being you experience in a Mercedes is difficult to put into words, we have nevertheless succeeded in turning it into a precise science.

Using a highly advanced computer simulation technique, we are able to design exceptionally ergonomic interiors. With some particularly clever 3-D technology, we can re-create human behaviour and movement patterns – such as putting on a seat belt or switching on the radio – with absolute precision at the click of a mouse. We can even see things through the driver's eyes in order to determine if the steering wheel provides a clear enough view of the instrument cluster or to check the field of vision offered by the mirrors. Of course, everybody is different. That is why we have loaded our computers with data describing thousands of people, representing a wide spectrum of the population. These data – which comprise factors such as gender, age, body

size and seating posture – ensure that you and your R-Class form a perfect team.

Features developed using this technology include the driver's seat with its standard-fit lumbar support. The R-Class can also be equipped with an optional memory package which remembers the position of the seat, the exterior mirrors and the steering column.

From the driving seat, you reign supreme over the stylishly appointed interior. On the steering wheel there are two gearshift keys and buttons which allow you to control the multifunction display, radio and telephone, while the DIRECT SELECT lever for the automatic transmission is situated on the steering column.

The centre console brings together all the controls for the interior temperature settings, communication systems and the optional COMAND APS control and display system.

First-class travel, even in the second row

Luxury appointments in the rear

The rear occupants of the R-Class are able to lean back and relax in comfort on the 3-seater bench: the second seat row has two luxurious executive chairs and a comfortable centre seat as standard.

The optional CD/DVD-player of the rear entertainment system is located in the centre console, between the driver and front passenger seats. It enables passengers in the rear to watch films on 7-inch screens integrated into the head restraints of the front seats - or even television if the optional TV tuner is specified. Up to two games consoles can also be connected.

The rear face of the centre console is equipped with a 12-V socket and, as an option, two pull-out cup holders. This face also accommodates the controls for the optional THERMOTRONIC luxury automatic climate control with an additional rear air conditioning unit. The additional nozzles for this are located in the rear sidewall panels.





Ideally situated, superb views, 2.217 m x 1.246 m living area

The spaciousness and flexibility of the R-Class

The R-Class is so accommodating that it feels like a real home from home. With a load compartment length of 1.982 m (2.217 m in the long-wheelbase version) and a width of 1.246 m, it is the roomiest passenger car we have ever built. Which explains why you can easily stow six suitcases onboard: folding all the rear seats down produces a level loading surface extending from the front seat backrests to the tailgate. And thanks to the low loading sill height of 695 millimetres, loading the R-Class is no problem either.

Loading is made even more straightforward with the optional EASY-PACK tailgate which operates electrohydraulically and can be opened and closed by means of a remote control unit or switch. This option also includes a useful load compartment cover, but if preferred these two features can also be ordered independently.





Load compartment floor

In standard trim the R-Class is a 5-seater with a large load compartment flap recessed into the load compartment floor. In this way the generous luggage space is supplemented with an additional, 51-litre stowage compartment



We attach particular importance to the safety of the little ones

The child safety seat concept of the R-Class

The R-Class also scores heavily as a family car. Even junior family members benefit from the extraordinarily generous interior space, with room for up to three child seats in the second seat row. And because the comfort and safety of our future customers is particularly dear to our heart, the two outer seats are fitted with ISOFIX child seat attachments which enable the seat to be directly anchored to the vehicle body. A level of safety is possible when you install a child seat on the

front passenger seat: the optional child seat recognition system automatically deactivates the front passenger airbag as soon as it detects a child seat on the front passenger seat. You only need to ensure that you use a special child seat equipped with a transponder, which is available as a Mercedes-Benz accessory. So as you see, even a large family will not stretch the R-Class to its limits.



Rest and relaxation should already begin during the journey.

Whether for professional or private use – the R-Class has the right answers for practically any day-to-day requirements. The generously dimensioned 5-seater with its highly intelligent spatial concept will always deliver you and your passengers to your destination in a relaxed state of mind. Thanks to maximum variability, as the interior of the R-Class is truly a quick-change artist. For example, the centre section of the second seat row in the 5-seater can simply

be folded down when required, transforming it into a practical and comfortable centre armrest. And should you need to carry something particularly large or bulky, completely folding down the rear seats opens up an impressive loading capacity of up to 2001 litres, with a maximum depth of 1.982 metres. Because one thing is certain: the limits of your possibilities should only be defined by you – and not by your vehicle.





The rear of the 4+2-seater R-Class with the optional rear centre console in the second seat row

The R-Class: group travel is back in style

Space and comfort for up to seven occupants

As an option the R-Class can be equipped with three seat rows. As a 4+2-seater it not only offers generous space, but also comfortable single seats with armrests in the second row. By virtue of their width and high-quality upholstery, these provide a level of comfort similar to the front seats. A rear centre console with two cupholders and numerous stowage facilities is available as an option. If preferred the R-Class can also be ordered as a 5+2-seater. This version of the SUV Tourer is equipped with a rear air suspension and level control as standard. Particularly easy access and egress is ensured by the EASY-ENTRY function, which is provided in conjunction with the 4+2 and 5+2-seater. In this case the third seat row, which is identical in both versions, replaces the stowage compartment in the load compartment floor.

The single seats in the third row are identically available for the 4+2 and 5+2-seater



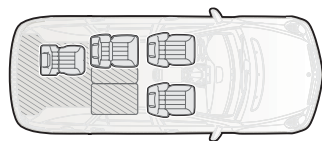
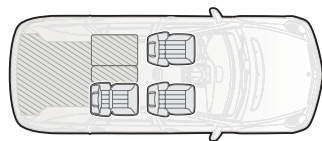
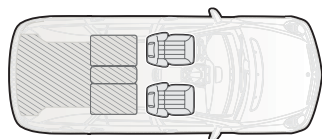

Whether in the standard 5-seater or the optional 4+2 and 5+2-seater – all the seats can be individually folded down for the greatest possible versatility



5-seater (standard specification)



4+2-seater (optional)

Up to seven luxury seats on request

The variable seating concept of the R-Class

The interior of the R-Class not only offers generous personal space, but also plenty of room for the imagination. The SUV Tourer has five seats as standard, but two, three, four, six or seven seats are also possible. If only two seat rows are occupied and the 5-seater is loaded to roof level, a maximum load capacity of 939 litres is available (4+2 and 5+2-seater 888 litres). As a two-seater, the basic R-Class offers a load capacity of

2001 litres when loaded to roof level, or 1950 litres in the 4+2 and 5+2-seater. Reconfiguring the interior in this way is quick and easy: creating a level load area is simply a matter of folding the cushions and backrests of the second and third rows forward. And even with a full complement of seven occupants, the luggage compartment still has up to 324 litres of space for light baggage when loaded to roof level.



5+2-seater (optional)

An extra measure of greatness

The 5.173 m long-wheelbase version leaves nothing to be desired

The R-Class is already multi-talented in the standard length of 4.938 metres. If even this is not enough, why not opt for the long-wheelbase version. The advantage is that if six or seven occupants are on board, those sitting in the third seat row will be even more comfortable. With even more room for luggage as well – in fact a load capacity of 414 litres to roof level. If only the first and second seat rows are in use, the load capacity of the 5-seater is 1118 litres, or 1067 litres in the 4+2 and 5+2-seater (179 litres more than in the standard version). You also benefit from a load compartment that's 1.075 metres long. The seats in the second row can be moved fore

or aft individually to create a distance of up to 990 mm from the front row of seats – a degree of spaciousness and comfort comparable to that found in luxury saloons. The telling difference in the R-Class: in two-seater configuration, the long-wheelbase 5-seater version can, if required, offer a load capacity of up to 2436 litres, or 2385 litres for the 4+2 and 5+2-seater versions (435 litres more than the standard version), while the maximum loading length grows to 2.217 metres. That means plenty of space for a surfboard, mountain bike or any number of holiday souvenirs. (The R 280 CDI 4MATIC is not available in long-wheelbase form.)

In comparison
The 235-mm longer R-Class provides not only more stowage facilities, but enhanced comfort, too

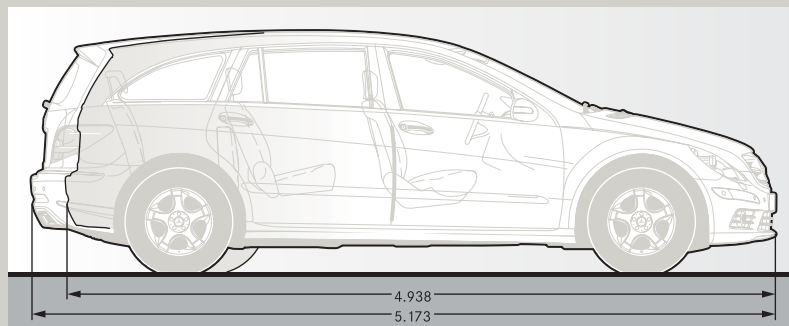



Agility

Thirteen good reasons for the R-Class

Versatility is the key: powerful engines, rear-wheel or four-wheel drive and air suspension

With a total of 13 basic versions, the R-Class offers an enormous range of configurations. It will also surprise you with its wealth of technical refinements and an agility that makes every trip a real pleasure. There is also a choice of rear-wheel or four-wheel drive models: the V6 petrol engine R 280 has rear-wheel drive, the V6 diesel R 280 CDI and the V6 petrol R 350 are available with either rear-wheel or four-wheel drive, and the V6 diesel R 320 CDI as well as the top-of-the-range R 500 with a V8 petrol engine always feature 4MATIC permanent four-wheel drive for extra traction. This system applies specific brake pressure to wheels with insufficient traction, while increasing torque at the wheels with good traction. Whichever engine variant you choose – you will benefit from a suspension that is tailor-made for both winding country roads and fast motorways. An experience you can heighten even further with the optional AIRMATIC package – all-round air suspension together with the Adaptive Damping System ADS. All these features ensure that driving becomes a relaxed and effortless pleasure.

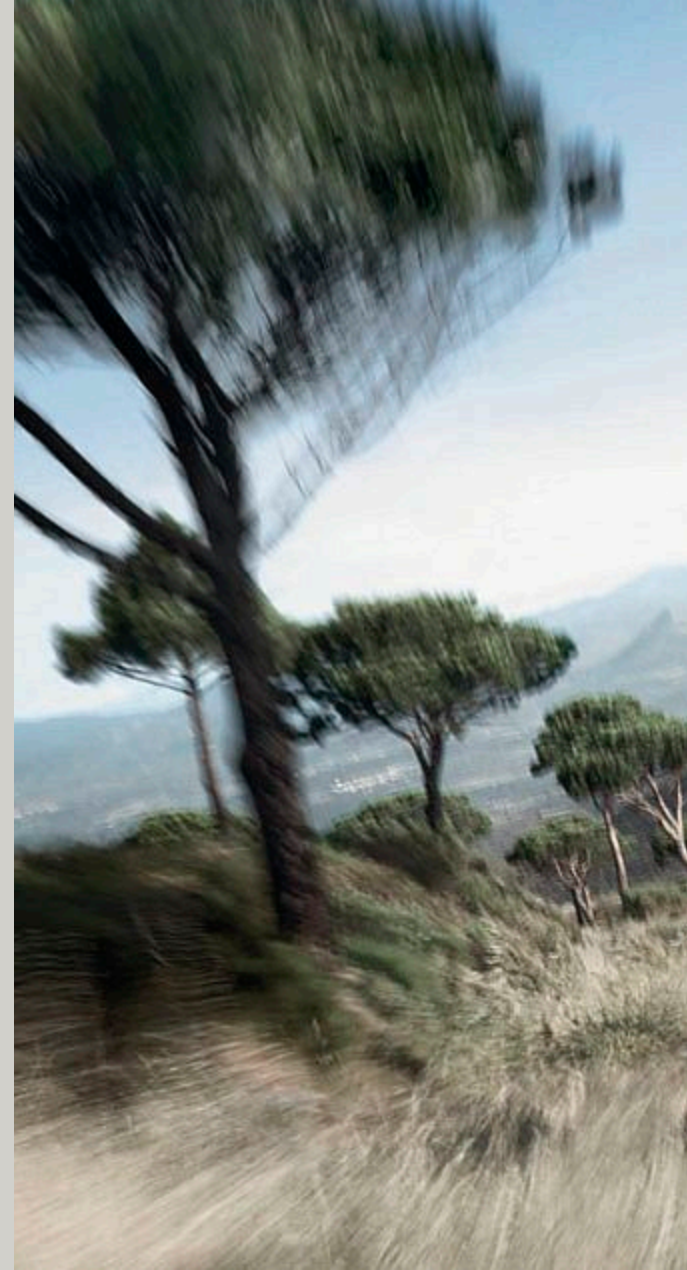



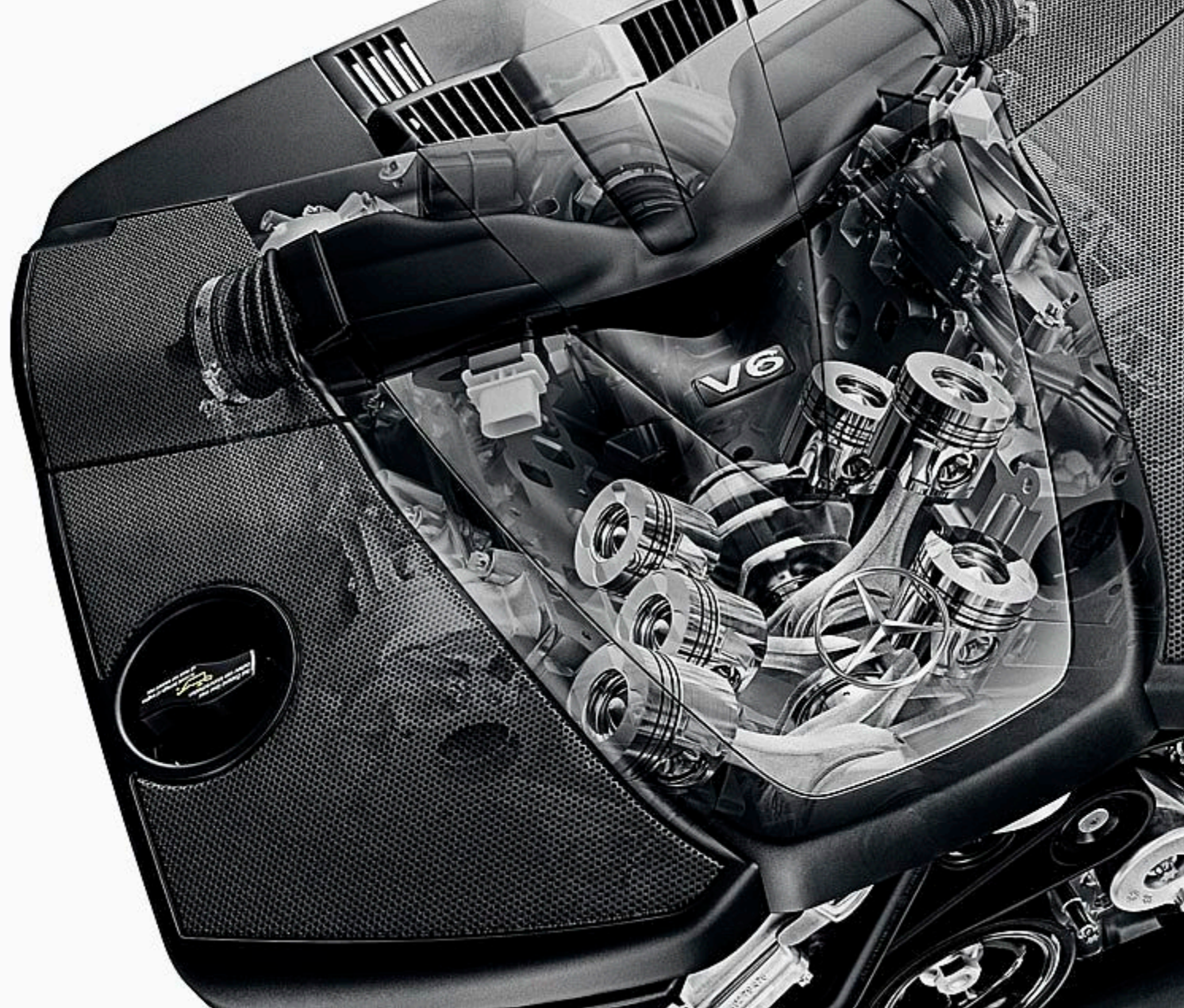

The V6 CDI diesels

The impressive torque figures are the result of optimised common-rail technology with multi-point injection and variable turbocharger geometry

You may not hear much from our diesel engines, but you'll hear plenty about how good they are

The CDI models with the latest-generation common rail technology

The V6 CDI diesel engines in the R 280 CDI¹ and the R 320 CDI 4MATIC are particularly impressive with their exceptional smoothness and enormous torque: the 440 and 510 newton metres which they develop respectively ensure that plenty of power is available, even at low revs. The R 280 CDI¹ has an output of 140 kW (190 hp), while the R 320 CDI 4MATIC develops 165 kW (224 hp).

High performance teams up with low fuel consumption and low pollutant emissions in these engines. Fitted as standard with a diesel particulate filter which does not require fuel additives in order to function, they deliver high performance but low CO₂ emissions. Up to 95 % of the particles can be removed from the exhaust gas.

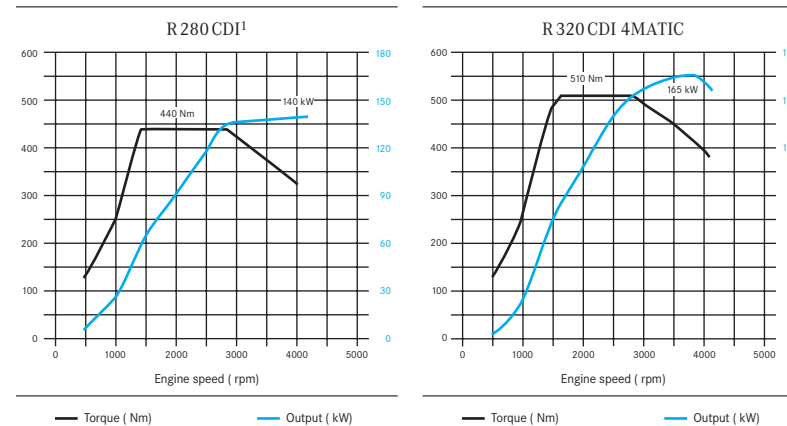

¹ Also available as a version with 4MATIC four-wheel drive

The CDI diesel engines
Two ways to be quick off the mark. The V6 CDI engines already develop their maximum torque at low revs

You'll be impressed by the capacity of the engines, too

The V6 and V8 petrol engines for the R-Class: assured performance in every situation

The R 280 and R 350¹ show the sensational effect which can be achieved through understatement. These V6 engines with four valves per cylinder and continuous camshaft adjustment provide power and responsiveness in full measure. 170 kW (231 hp) for the R 280 and 200 kW (272 hp) for the R 350¹ provide plenty of pulling power for fast acceleration in any gear. Even in high gear, the petrol engine delivers a relaxed driving experience while returning good fuel economy.

Effortless superiority in any driving situation is the defining characteristic of the new 8-cylin-

der engine in the R 500 4MATIC. The figures tell their own story: 285 kW (388 hp) and a maximum torque of 530 Nm. The R 500 4MATIC accelerates from 0 to 100 km/h in just 6.1 seconds. Variable intake and exhaust camshafts, as well as extensive use of lightweight materials such as magnesium, ensure excellent fuel economy for this vehicle class. And just to make sure that all this power is delivered as comfortably as possible, the standard 7G-TRONIC automatic transmission does the gearshifting for you.

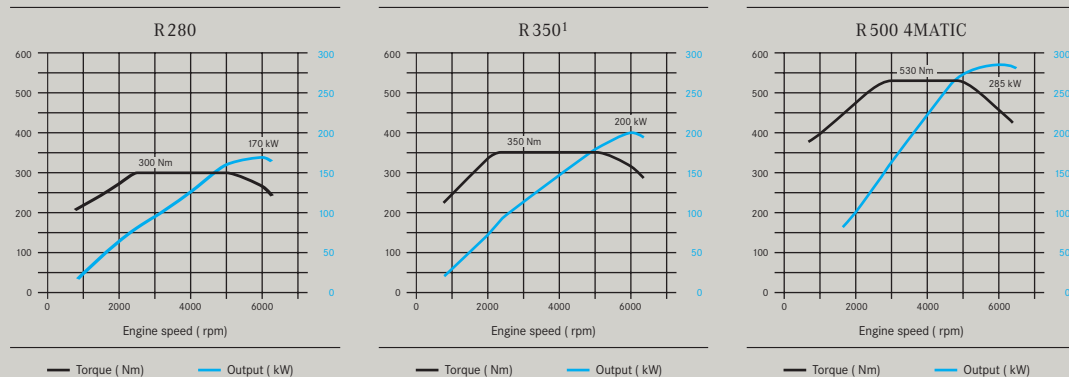

¹ Also available as a version with 4MATIC four-wheel drive





Small steps can make a big difference

The 7G-TRONIC 7-speed automatic transmission is more closely geared to shift more smoothly

7G-TRONIC embodies the latest transmission technology to deliver an exceptionally comfortable ride. Seven forward gears mean that the ratios are more closely spaced over a wide ratio spread, with the result that you are hardly aware of the shifting process. When changing down, 7G-TRONIC's multiple downshift capability means that it can accelerate the process by skipping several ratios. A torque converter lockup clutch, which engages even in first gear, and the transmission control logic also help to save fuel and optimise acceleration.

Thanks to standard-fit DIRECT SELECT, the centre console in the R-Class remains refreshingly clear: selection of the automatic transmission settings is easy using the selector lever behind the steering wheel. You can choose between P, R, N and D, without having to take your hand off the steering wheel. There is a choice of two driving programmes: "S" for "Sports" and "C" for "Comfort". Whichever programme is currently active is indicated in the instrument cluster. Or, if you want to take the shifting process in hand yourself, all you have to do is use the standard-fit DIRECT SELECT steering-wheel gearshift buttons.



DIRECT SELECT

Briefly moving the steering-column selector lever is all it takes to select the driving mode

7G-TRONIC

Developed with the experience gained from producing more than eleven million automatic transmissions in over 40 years

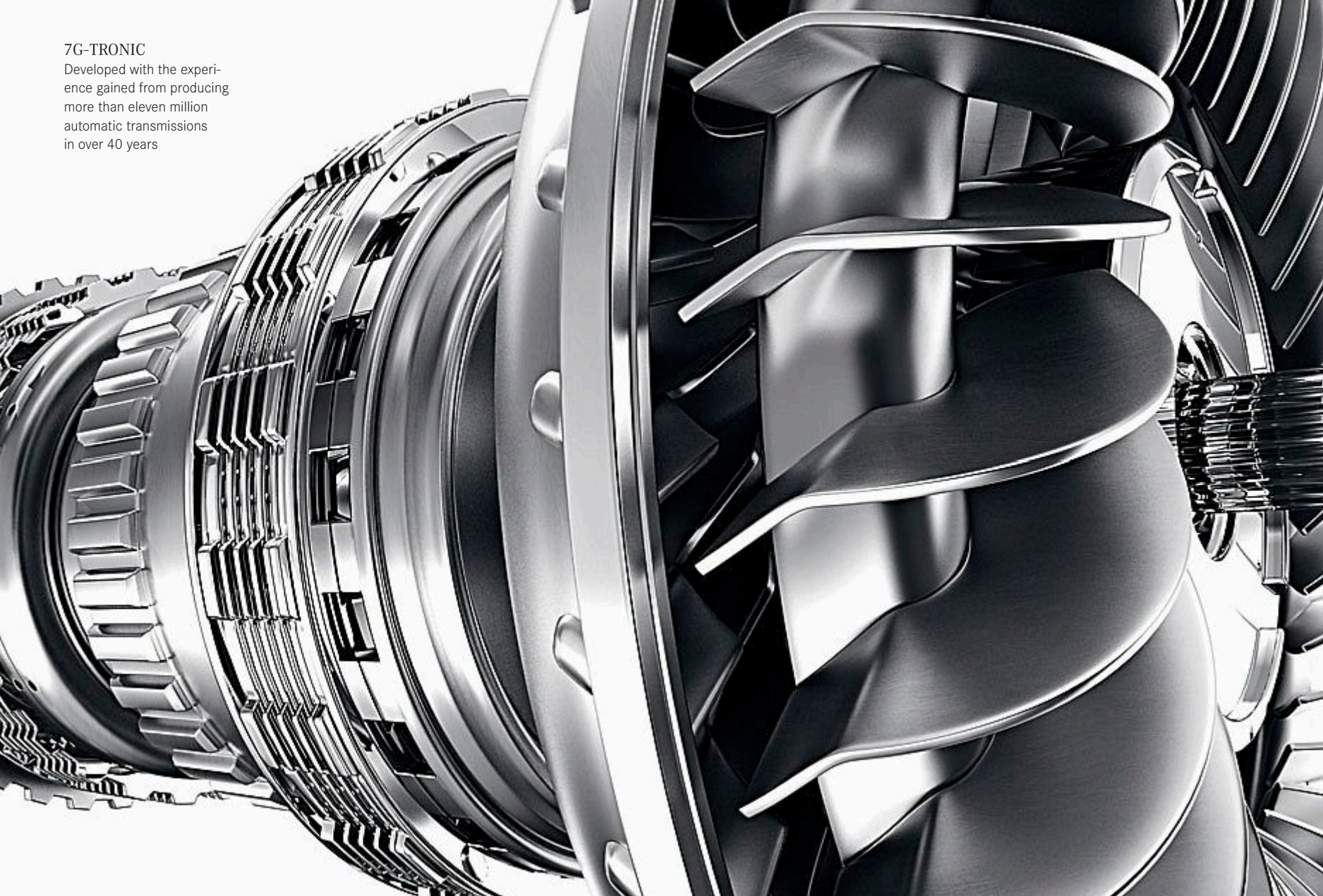



Plenty of space also means plenty of room for top-class technology

Enhanced handling dynamics with the agile suspension and, depending on model, 4MATIC four-wheel drive

The R-Class has a large number of intelligent systems on board. The optional 4MATIC¹ four-wheel drive system, a sophisticated suspension design, the long wheelbase and numerous dynamic control systems ensure an extraordinarily comfortable journey. Front wheel location is by a double-wishbone axle for improved ride comfort and handling dynamics, while the rear wheels are located by a sophisticated four-link axle. The 5-seater and 4+2-seater feature an all-steel suspension, while the 5+2-seater and R 500 4MATIC have a rear air suspension with level control as standard. On request all models are available with the AIRMATIC package, which has all-round air suspension for even greater ride comfort.

Working in combination with the Adaptive Damping System (ADS), the system ensures an improved suspension response even when the vehicle is fully laden. At speeds above 120 km/h the suspension is lowered automatically, thereby reducing drag and, as a consequence, fuel consumption. The AIRMATIC package also allows

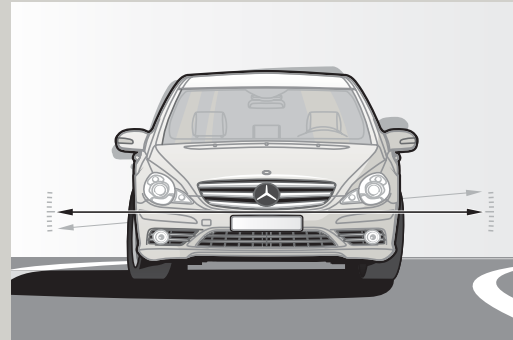

AIRMATIC package
The air suspension works in conjunction with the Adaptive Damping System (ADS), which automatically optimises the shock-absorber response in accordance with the driving situation. Pitching and rolling – during fast cornering or on poor roads, for example – are reduced as a result

the suspension to be raised by up to 50 mm at the touch of a button in order to increase ground clearance when negotiating poor road surfaces, for example.

You can also count on the assistance of the optional 4MATIC all-wheel-drive system, which distributes the drive torque between the front and rear wheels in a ratio of 50:50. Working in combination with dynamic control systems 4ETS and ESP®, 4MATIC provides a high degree of traction – especially on unstable surfaces, in the wet or on ice or snow.

¹ Standard for R 320 CDI 4MATIC and R 500 4MATIC







PRO-SAFE™
THE INTEGRAL SAFETY CONCEPT
FROM MERCEDES-BENZ

A theory which can save lives in practice

PRO-SAFE™: highly sensitive protective systems for outstanding safety

Hardly anything inspires us to produce consistently impressive results quite as much as the research into new safety technology. As early as the 1950s, we reached an important safety milestone when legendary vehicle safety pioneer Béla Barényi invented the passenger safety cell. This era also saw revolutionary ideas put forward by many of our other employees – Rolf Maier, for instance.

In order to study the crash performance of steering and restraint systems quickly and cost-effectively, Rolf Maier and his engineer colleagues designed and built a special sled which was driven into a wall at high speed. To simulate the crumple zone, the team used gherkin tins from the staff restaurant – a simple yet brilliant solution which typifies the creative spirit that characterised this pioneering time.

Of course, much has happened since then. Highly advanced technology now makes our

vehicles particularly safe – not only in an actual collision. Today, our development activities are focused on measures which bring us closer to our vision of accident-free driving. They are part of our PRO-SAFE™ philosophy which comprises four areas: this encompasses all the components that support safe driving, identify critical situations in time to give a warning and provide appropriate assistance. In the second phase, in the event of danger, the optional PRE-SAFE® system prepares the occupants and the vehicle if there is a high probability of an accident occurring. The PASSIVE-SAFE systems can provide the passengers with appropriate protection during a collision. POST-SAFE comprises measures which help to increase occupant protection after an accident.

Further information about the Mercedes-Benz safety concept is available online at www.mercedes-benz.com/sicherheitsbroschueren.



The R-Class can recognise hazards sooner so that you don't have to deal with them later

Avoiding hazardous driving situations is the principal safety goal for the R-Class

The standard-fit Headlamp Assist feature activates the lights entirely automatically to make driving in the dark safer. Bi-xenon headlamps with the active light function, dynamic range adjustment, headlamp cleaning system and cornering light function are available as an optional extra for your R-Class. The active light function follows your steering movements and improves illumination on bends by as much as 90%. On request the standard foglamps can be given the cornering light function, which is automatically activated at speeds of up to 40 km/h when the vehicle is turning or cornering and you operate the indicators, or on tight bends. Also available as an option, the DISTRONIC proximity control system helps you keep your distance from the vehicle

ahead when travelling at speeds between around 30 and 180 km/h. The system can brake the car by up to 2 m/s^2 if necessary, and then accelerate it automatically to the preset speed if appropriate.

If there is a risk of skidding – on a wet road, for example – the dynamic handling control systems, which have been specially optimised for the rear-wheel and all-wheel drive of the R-Class, can intervene to provide improved traction. As soon as the sensors detect a critical dynamic handling situation, brake pressure is applied to one or more wheels as required and the engine output may also be adjusted. ESP® and 4ETS work together with the Brake Assist (BAS) and acceleration skid control (ASR) functions. ESP® trailer stabilisation is also a standard feature.

Active light function

To help you see obstacles at an earlier stage, the R-Class is available with the optional active light function which improves illumination of the road by up to 90% in curves

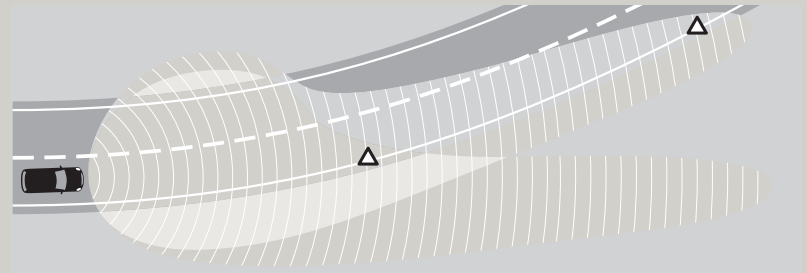



When there's no time to think, the R-Class has already taken the necessary action

The preventive PRE-SAFE® system initiates occupant protection measures as a precaution

The very instant you step on the brake pedal in an emergency, for example, you can be sure the R-Class is already on full alert thanks to its highly advanced sensor systems. This means that, if the emergency develops into an accident, you will be protected earlier and, therefore, even more effectively. After all, a fraction of a second can make all the difference in an emergency.

The optional PRE-SAFE® system works together with a number of systems, including the sensors of the Electronic Stability Program (ESP®) and Brake Assist (BAS). If these identify a critical situation, the driver and front passenger seat belts are tensioned instantly, the front passenger seat is adjusted to a more favourable position (only in conjunction with the optional memory package), and if a certain lateral acceleration threshold is exceeded the sunroof is closed. Once the danger has passed, the belt tensioning is released. All the other systems can then be returned to the desired positions manually.

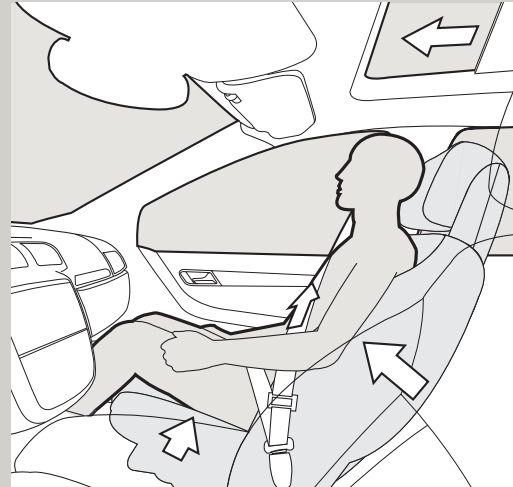

PRE-SAFE®

Making sure a quick shock has no lasting effects: depending on the driving situation and vehicle specifications, the anticipatory occupant protection system tensions the seat belts, repositions the front passenger seat if required and even closes the tilting/sliding sunroof along with the side windows

Airbags

A great team that responds instantaneously but also knows when to hold back. The front airbags are triggered in one or two stages depending on the severity of the impact

The passenger cell

The energy-absorbing front and rear sections as well as the doors with their high-strength reinforcing elements form an effective defensive barrier

Front impact structure

Two crash boxes made from high-strength steel absorb much of the impact energy in front-end collisions at speeds up to 15 km/h. As a result, the body structure to the rear remains intact



Our leading players are always there

In the event of an accident, this is where the R-Class shows it has backbone



Side impact structure

High-strength steel, exceptionally strong longitudinal members and triple-layer sidewalls provide protection in a side impact

A high-strength passenger cell built from high-quality materials and offering long deformation paths provides a reliable protective barrier for the occupants if the worst should happen. But in designing the bodyshell, we also paid particular attention to the question of how to reduce the risk of injury to other road users.

Should a collision nevertheless occur, a sophisticated system of airbags can come to the rescue. The driver and front passenger seats are equipped with front airbags (which deploy in two stages,

depending on accident severity) as well as sidebags. The second seat row can have sidebags integrated into the backrests as an option. In the event of a side collision, or a roll-over, windowbags can expand like a curtain to protect all the seat rows. The driver and front passenger seats, as well as the rear seats in the 5 and 5+2-seater, are fitted with 3-point seat belts and belt tensioners as standard. Like the front seats, the outer seats in the second row also feature belt force limiters.

NECK-PRO head restraints

In a rear impact above a given degree of severity, the crash-responsive NECK-PRO head restraints move forwards and upwards to help prevent whiplash. NECK-PRO head restraints are available as an option for the driver and front passenger

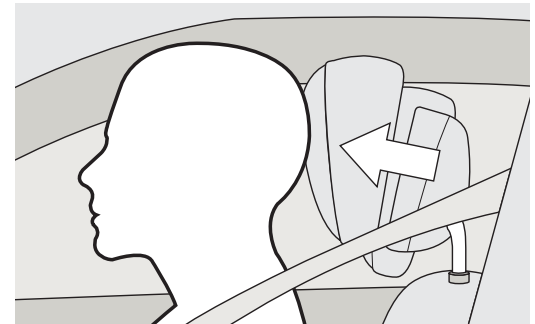





My R-Class





The R-Class: we build it, but you make it what it is

Standard and optional equipment

The versatility of the R-Class is well-matched by the wide range of available appointments. So whatever you plan to do with your R-Class, it will be ideally equipped. The individualisation options already start with the visual appearance: the interior of the V6 models features matt aluminium trim, with seats upholstered in a combination of Aspen fabric and ARTICO man-made leather. The standard appointments of the R 500 4MATIC include an interior with bird's-eye maple trim and ARTICO man-made leather. All R-Class models feature a twin exhaust system with a chrome tailpipe. Other equipment packages are also available, for example the exterior sports package

which includes dynamic light-alloy wheels, or the interior sports package with aluminium inserts and many other attractive features. Naturally the list of appointments includes many items designed to enhance practicality and comfort. More thought has been devoted to passenger comfort than in almost any other car. The occupants in the second and third seat rows are particularly well catered for: the range of options extends from a rear entertainment system to the interior lighting system and THERMOTRONIC automatic climate control, and right up to an especially large panoramic glass sunroof.

More than 40 items with one objective: to make you feel good

The comprehensive standard equipment of the R-Class

A look at the standard equipment provides confirmation of the remarkable skill with which opposites have been reconciled in the R-Class. There is a transmission which made its debut in the world of motorsport, an automatic climate control system and a multifunction steering wheel that simplifies a multitude of tasks (including

operating the Audio 20 CD radio), as well as a comfortable 3-seater bench for passengers in the rear. The interior flexibility of the R-Class also puts many a rival in the shade, not to mention the extensive safety systems included as standard. In short, the R-Class offers everything you need for a pleasant journey.

THERMATIC automatic climate control



Leather multifunction steering wheel



Audio 20 CD radio



STANDARD EQUIPMENT (SELECTION)

18-inch light-alloy wheels for the V6 models, 19-inch for the R 500 4MATIC
4MATIC permanent all-wheel drive for R 320 CDI and R 500
5-seater with 4 executive chairs (semi-electrically adjustable in the front) and a centre seat
7G-TRONIC 7-speed automatic transmission
Airbags with multi-stage deployment logic, sidebags for driver and front seat passenger plus windowbags for all rows of seats
Aluminium trim elements on doors, dashboard console, centre console and dashboard
Anti-lock braking system ABS
ASSYST PLUS service interval display with service computer
Audio 20 CD radio with telephone keypad, eight loudspeakers
Aux-in connection in the glove compartment
Brake Assist BAS
Central locking with interior switch and crash sensor
Combination of Aspen fabric/ARTICO man-made leather upholstery
Cruise control with SPEEDTRONIC variable speed limiter
Cup holders in the front (2)
Diesel particulate filter in the R 280 CDI, R 280 CDI 4MATIC and R 320 CDI 4MATIC
DIRECT SELECT steering-column selector lever and steering-wheel gearshift buttons
Electronic immobiliser incl. locking system with radio/infrared remote control (recognised by AZT [Allianz Technology Centre] and TÜV [German technical inspection authorities])
ESP®/ETS (Electronic Stability Program and Electronic Traction System) with ESP® trailer stabilisation
Exit lights and reflectors (4), additional reflector in tailgate
Five head restraints, manually adjustable for all seats
Fog lamps with chrome surround and rear foglight

Folding front armrest (between driver's seat and front passenger seat) with phone compartment and stowage compartment
Headlamp Assist
Heated exterior mirrors, electrically adjustable from inside, finished in vehicle colour, with aspherically curved mirror glass and integral indicators
Hill start assist
ISOFIX child-seat attachment points for outer seats of second seat row
Leather multifunction steering wheel
Load-securing rings (8)
Outside temperature display
Power windows (4)
Pre-installation for roof carrier systems
Rear apron with optical scratch protection
Seat occupancy sensor in passenger seat
Speed-sensitive power steering
Steel suspension (for R 500 4MATIC: rear air suspension with level control)
Steering column manually adjustable for reach and height
Stowage space in the load compartment floor (51 litres), exclusively in the 5-seater
THERMATIC automatic climate control with combination filter
Three-point seat belts with adaptive belt force limiters (not available for centre seat) and belt tensioners
Tinted glass all round, rear window in single-layer safety glass
TIREFIT tyre repair kit with electric pump
Two-pipe exhaust system with visible, oval tailpipes in chrome
Tyre pressure loss warning system
Windscreen wipers with one-touch wiper function and rain sensor with infinitely variable intermittent wipe setting



Show your mettle

Light-alloy wheels for every taste

There are many ways of getting the R-Class up to speed: the range extends from 18-inch light-alloy wheels to special, AMG-designed 21-inch light-alloy wheels painted in titanium silver – this is the largest wheel size available from the Mercedes-Benz wheel range. Other wheels are available from our accessories range.

Optional part of the exterior sports package: the 19-inch 5-spoke light-alloy wheel with mixed-size tyres with size 255/50 R 19 at the front and 285/45 R 19 at the rear



Standard equipment for the V6 models: 18-inch twin-spoke light-alloy wheels, size 255/55 R18



Standard for the V8 model: the incenio "Situla" 19-inch designer wheel painted in sterling silver, size 255/50 R19



Optional extra: 18-inch 10-spoke light-alloy wheels, size 255/55 R18.



Part of the exterior sports package: the 19-inch 5-spoke light-alloy wheel, size 255/50 R19



Optional: 20-inch 5-spoke AMG light-alloy wheel, high-shine finish, size 265/45 R20



Optional: 21-inch 5-spoke AMG light-alloy wheel, painted in titanium silver, size 265/40 R21

Where extras play a starring role

incenio designer wheels from our range of genuine accessories

It is often the carefully crafted details that make the difference: take the incenio designer wheels from our range of genuine accessories, for instance. The incenio “Angetenar” 18-inch designer wheel for tyre size 255/55 R 18 features six spokes and a titanium silver finish, high-sheen. Another particularly elegant example is the incenio

“Sadalmelik” 19-inch 5-spoke designer wheel painted in sterling silver and available in size 255/50 R 19 and 285/45 R 19 for the rear axle. And if you like your details a little larger, consider the “Alanz” 20-inch wheel with its 5-twin-spoke design. Wearing 265/45 R 20 tyres, it gives the R-Class a particularly powerful presence.



incenio “Angetenar” 18-inch designer wheel with high-sheen finish, size 255/55 R 18



The incenio “Sadalmelik” 19-inch designer wheel painted in sterling silver, size 255/50 R 19 and 285/45 R 19 for the rear axle

The incenio "Alanz" 20-inch designer wheel, size 265/45 R20



The sky's the limit

From the rear-seat entertainment system to the panoramic glass roof

In view of the substantial exterior dimensions of the R-Class, it is hardly surprising that it offers plenty of space for extras. You can emphasise its sporty side with the styling package or one of the sports packages or by choosing special light-alloy wheels. For your comfort and convenience, the range includes a reversing camera (in conjunction with COMAND APS) which makes manoeuvring into parking spaces easier. And on the practical side, there is a rear centre console for the 4+2-seater, the EASY-PACK tailgate and various solutions for organising the luggage compartment. Safety systems which can provide you with an even higher level of accident protection – the crash-responsive NECK-PRO head restraints, for example – are

also on the options list. In-car entertainment is another field in which you will find a wide choice: the range includes radios with a CD player and navigation system, as well as a TV tuner available in conjunction with COMAND APS and a rear-seat entertainment system. So you can turn your R-Class into your own, personal drive-in or concert hall. If you prefer that open-air concert feeling, it can be created by choosing a tilting/sliding sunroof or the particularly large panoramic glass roof (see photo at right). Substantially larger than conventional sunroofs, it occupies almost the entire roof area and floods the spacious interior with natural light.





The panoramic glass roof
Admits more light than most
sunroofs

COMAND APS with its clearly legible 6.5-inch colour display





COMAND APS allows you to look up phone numbers and make calls



The reversing camera makes manoeuvring into spaces easier by showing the area to the rear of the vehicle on the COMAND display



Acoustic perfection: the harman/kardon LOGIC7® surround sound system is controlled from this screen

COMAND APS: intelligence meets entertainment

Your information, navigation and audio centre

Telephone, navigation and audio functions aboard the R-Class can be combined in one user-friendly interface with the COMAND APS control and display system. Whether you want to listen to the radio, call a phone number, play a CD or be guided to your destination quickly and easily – everything comes together in COMAND APS.

COMAND APS features a 6.5-inch colour display, a CD drive and a DVD navigation system with an extremely high storage capacity. A colour map display indicates the route which the navigation computer calculates on the basis of input from the satellite-based Global Positioning System (GPS) and the wheel-speed sensors of the anti-lock braking system. An electronic compass display is also integrated in COMAND APS. The ultimate operating convenience is provided by the optional LINGUATRONIC voice control system, which for example allows you to adjust the radio volume without moving a muscle.

Once you have reached your destination, another optional feature can help you with parking. The reversing camera provides you with visible and audible warnings of obstacles. When you are reversing, the COMAND display shows you the area to the rear of the R-Class. Housed in the tailgate handle, the camera is activated when reverse gear is selected.

All Mercedes-Benz radios are equipped with a speed-sensitive volume control system which increases the sound level progressively at speeds above 20 km/h.

The most demanding music fans will settle for nothing less than the harman/kardon LOGIC7® surround sound system with eleven loudspeakers (instead of the standard eight) and a subwoofer. This 440-watt system is tuned so precisely to the R-Class that neither the speed of the vehicle nor external noise can compromise its acoustic quality.

A world of entertainment in the rear

Extras that make short work of long trips

While the driver enjoys the superb driving experience offered by the R-Class, the second-row passengers can sit back in comfort and enjoy movies on the move. All that is required is the optional rear-seat entertainment system available for all seating variants, which comprises a CD/DVD player, 7-inch screens integrated into the head restraints, two headphones and a remote control unit. A TV tuner is also available as an option (in conjunction with COMAND APS and the rear-seat entertainment system), and a games console can be connected to each screen.

As in all the best cinemas, there are two optional cupholders in the rear as well as ample stowage facilities – perhaps for the popcorn.

These features are part of the optional rear centre console, whose damped-hinge cover doubles as an armrest. The compartment inside offers seven litres of stowage space. The rear centre console is removable (available for the 4+2-seater).

Whether you're watching an action movie set in the Sahara or a documentary about the Arctic, the optional multi-zone THERMOTRONIC luxury automatic climate control will make sure that the temperature on board is always just right. This system allows three temperature zones – for the driver, front passenger and rear section – to be controlled independently. The occupants of the second row of seats have access to duplicate controls for the rear temperature zone.

Multi-zone THERMOTRONIC

In order to maintain the required temperature setting in such a large space, the luxury automatic climate control system is equipped with nine sensors distributed across the whole of the interior

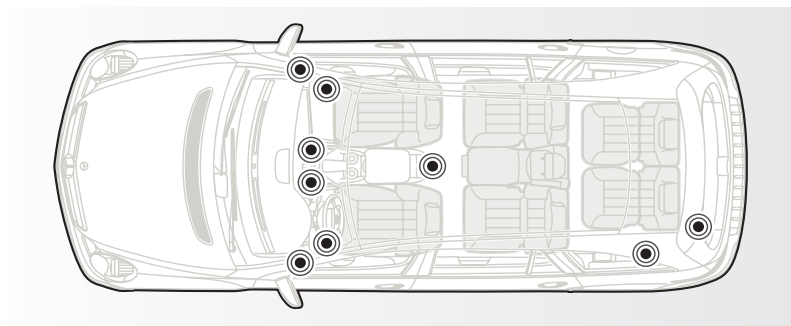

Rear-seat entertainment system



Multi-zone THERMOTRONIC



Rear centre console



The front sports seats (included in the interior sports package) provide particularly good lateral support



Hidden inside the multicontour seats, air cushions provide optimum back support for extra comfort

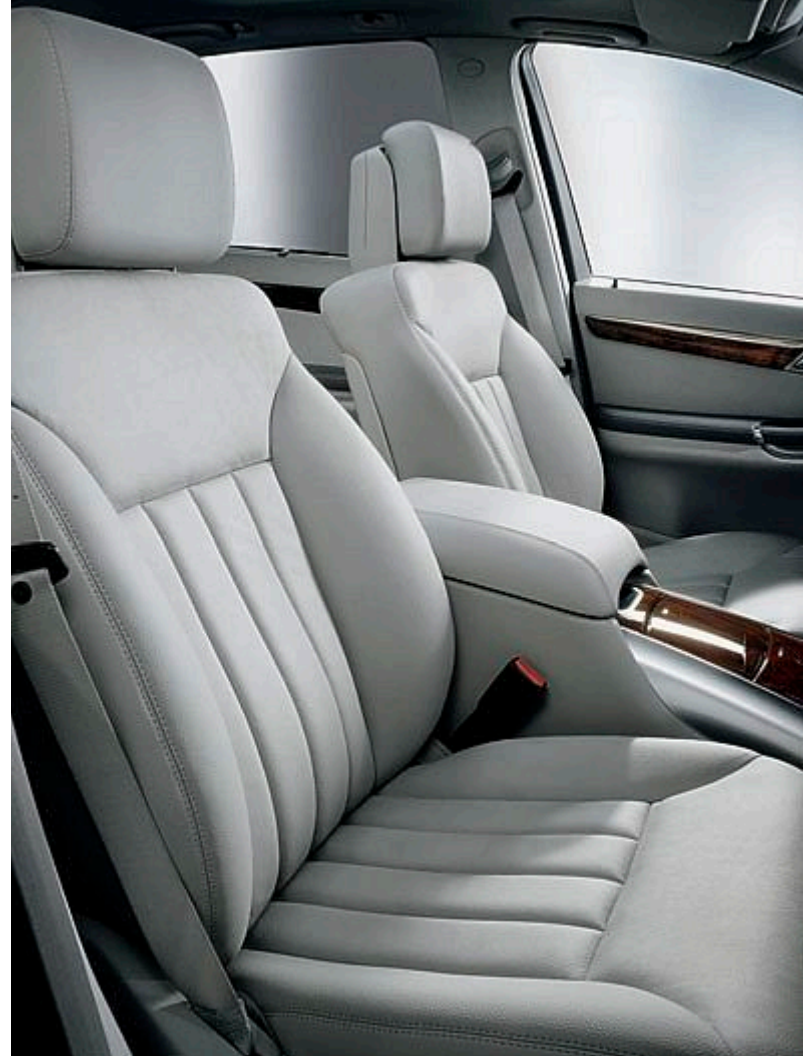

Sitting – in truth, only lying is more relaxing

Sports or multicontour seats: comfortably the best

The seats in the R-Class are designed to deliver you to your destination as refreshed and relaxed as you were at the start of the journey. That may sound like a tall order, but the “executive chair” seating fitted in the first and second rows (in the 5-seater, the two outer seats in the second row) offers a very high level of comfort. For the ultimate in seating luxury, you can choose heated and ventilated front seats. Or the multicontour seats which are available as an optional extra for the driver and front passenger. These seats are equipped with inflatable air chambers which adjust to your body and provide better support.

If you would like improved lateral support – especially when cornering – you can opt for front sports seats with higher side bolsters on the backrests. These seats, which are included in the interior sports package, are electrically adjustable and are upholstered in Alcantara/ARTICO man-made leather.

The memory package is another practical optional extra. As well as offering full electric adjustment for the front seats, the system can store the positions of the driver’s seat, head restraint, exterior mirrors and steering column for up to three people.

Seat adjustment

The memory package stores the position of the driver’s seat, steering column and exterior mirrors



KEYLESS-GO



Wood/leather multifunction steering wheel



Bi-xenon headlamps with active light function



Audio 50 APS radio



<i>OPTIONAL EXTRAS (SELECTION)</i>	R 280 CDI	R 280 CDI 4MATIC	R 320 CDI 4MATIC	R 280	R 350	R 350 4MATIC	R 500 4MATIC
18-inch 10-spoke light-alloy wheels	●	●	●	●	●	●	–
20-inch 5-spoke light-alloy wheels	●	●	●	●	●	●	●
21-inch 5-spoke AMG light-alloy wheels	–	●	●	–	–	●	●
Additional rear centre console for second row of seats (only available for 4+2-seater)	●	●	●	●	●	●	●
AIRMATIC package comprising: Adaptive Damping System (ADS) and all-round air suspension with level control	●	●	●	●	●	●	●
Anthracite poplar wood trim	●	●	●	●	●	●	●
Anti-theft alarm system with tow-away protection	●	●	●	●	●	●	●
ARTICO man-made leather, includes electric adjustment for front seats	●	●	●	●	●	●	□
Audio 50 APS radio with CD navigation system and colour display	●	●	●	●	●	●	●
Automatic child seat recognition in front passenger seat	●	●	●	●	●	●	●
Automatically dimming interior and exterior mirrors	●	●	●	●	●	●	□
Bi-xenon headlamps with active light function, headlamp cleaning system, dynamic headlamp range adjustment and cornering light function with fog lamp function	●	●	●	●	●	●	●
Bird's-eye poplar wood trim	●	●	●	●	●	●	□
Burr walnut wood trim	●	●	●	●	●	●	●
CD changer, MP3-compatible	●	●	●	●	●	●	●
Chrome package	●	●	●	●	●	●	□
COMAND APS control and display system with DVD navigation system	●	●	●	●	●	●	●
Dark-tinted thermal-insulation glass (rear side windows and rear window)	●	●	●	●	●	●	●
DISTRONIC proximity control	●	●	●	●	●	●	●
EASY-PACK load compartment cover	●	●	●	●	●	●	●
EASY-PACK tailgate with obstruction sensor	●	●	●	●	●	●	●

● Optional extra

□ Standard equipment

– Not available

<i>OPTIONAL EXTRAS (SELECTION)</i>	R 280 CDI	R 280 CDI 4MATIC	R 320 CDI 4MATIC	R 280	R 350	R 350 4MATIC	R 500 4MATIC
Electric panoramic glass roof with sun screen	●	●	●	●	●	●	●
Electrically folding exterior mirrors left and right	●	●	●	●	●	●	●
Electrically operated side vent windows in rear (third row)	●	●	●	●	●	●	●
Front multicontour seats	●	●	●	●	●	●	●
harman/kardon LOGIC7® surround sound system with twelve loudspeakers	●	●	●	●	●	●	●
Headlamp cleaning system	●	●	●	●	●	●	●
Heated front seats	●	●	●	●	●	●	□
Heated second-row seats	●	●	●	●	●	●	●
Heated windscreen washer system	●	●	●	●	●	●	●
Interior lighting package (in conjunction with leather and nappa leather, and included in interior sports package)	●	●	●	●	●	●	●
iPod® Interface Kit	●	●	●	●	●	●	●
KEYLESS-GO	●	●	●	●	●	●	●
Leather, includes electric adjustment for front seat and interior lighting package	●	●	●	●	●	●	●
LINGUATRONIC voice control system	●	●	●	●	●	●	●
Load-retaining net behind first and second rows of seats	●	●	●	●	●	●	●
Luxury front seats (heated and ventilated)	●	●	●	●	●	●	●
Memory package for driver's seat, exterior mirrors, steering column, in combination with electrically adjustable front seats	●	●	●	●	●	●	●
Metallic paint	●	●	●	●	●	●	●
Nappa leather, includes electric adjustment for front seats and interior lighting package	●	●	●	●	●	●	●
NECK-PRO head restraints for driver and front passenger	●	●	●	●	●	●	●
PARKTRONIC	●	●	●	●	●	●	●
Pre-installation for a mobile phone, with universal interface	●	●	●	●	●	●	●
PRE-SAFE®	●	●	●	●	●	●	●

<i>OPTIONAL EXTRAS (SELECTION)</i>	R 280 CDI	R 280 CDI 4MATIC	R 320 CDI 4MATIC	R 280	R 350	R 350 4MATIC	R 500 4MATIC
Rear air conditioning (only in combination with THERMOTRONIC)	●	●	●	●	●	●	●
Rear-seat entertainment system with CD/DVD player integrated in rear centre console, display with headphone jack integrated in the back of each of the front-seat head restraints	●	●	●	●	●	●	●
Reversing camera	●	●	●	●	●	●	●
Roller sunblinds in rear doors and sunshade for third row of seats	●	●	●	●	●	●	●
Sidebags for second row of seats	●	●	●	●	●	●	●
Sports package - exterior	●	●	●	●	●	●	●
Sports package - interior	●	●	●	●	●	●	●
THERMOTRONIC luxury automatic climate control (also for rear section)	●	●	●	●	●	●	●
Tilting/sliding glass sunroof, electric	●	●	●	●	●	●	●
Tinted, infrared-reflecting laminated glass	●	●	●	●	●	●	●
TV tuner, for analogue and digital reception	●	●	●	●	●	●	●
Wood/leather multifunction steering wheel, heated	●	●	●	●	●	●	●

● Optional extra □ Standard equipment – Not available

Panoramic glass roof



EASY-PACK tailgate - makes loading easier



Sunblind





For a particularly powerful presence

Always immaculately turned out with the chrome package

Already benefiting from many attractive design elements in its standard specification, the R-Class can be enhanced even further by means of the chrome package with the following external features: three-louvre radiator grille in sterling silver with chrome trim; body-coloured door handles and side rub strips with chrome inserts. The window frames and shoulderline trim strips are embellished with high-gloss aluminium highlights.



The door handles are finished in the vehicle colour and have a chrome insert



The matt-silver painted radiator grille has three louvres with chrome trim

Exterior features of the chrome package with chrome and aluminium highlights

Symbols of sporting achievement: chrome and silver

The sports packages for the exterior and interior

19-inch light-alloy sports wheels, dark red/grey rear light units and blue tinted glass are the features which identify an R-Class equipped with the exterior sports package. This equipment package also comes with the chrome elements from the chrome package, including a three-louvre radiator grille painted in silver with chrome trim, body-coloured door handles and side rub strips with chrome inserts, as well as window frames and shoulderline trim strips with high-gloss aluminium highlights.



Rear light units
in dark red/grey

The exterior sports package
with striking 19-inch
light-alloy sports wheels



The interior sports package includes a sports steering wheel and sports seats upholstered in Alcantara/ARTICO man-made leather



The upholstery with contrasting stitching is complemented by the aluminium highlights on the door trim strips



The high-gloss, carbon-look centre console



Striking features of the interior sports package include matt aluminium highlights on the door trim strips and dashboard which complement the high-gloss, carbon-look finish of the dashboard console and centre console as well as the silver-painted instrument cluster. Sports pedals are also part of the package.

An appropriately dynamic touch is added to the driving experience by the electrically adjustable front sports seats which offer optimised lateral support and are upholstered in Alcantara/ARTICO man-made leather with contrasting stitching.

The interior lighting package also forms part of the interior sports package.

Hallmarks of the interior sports package: aluminium and leather



The art of using contrasts to create harmony

The two-tone interior design of the R-Class

We developed the two-tone interior design for customers who wish to give their R-Class a very personal touch. The full effect of this interior, which is characterised by contrasting light and dark areas, only becomes apparent at second glance. A finely balanced combination of colours and materials creates a particularly harmonious yet extremely sporty interior atmosphere.

If this option is specified, the roof liner is in elegant black, while a light-coloured band colour-coordinated with the seats extends along the interior door panels and into the luggage compartment. The carpets in the footwells are in a contrasting, darker colour. In this way the entire interior is framed in black, further accentuating the elegant overall impression. This interior option is available in a combination of black/cashmere beige or black/alpaca grey, with a further choice of leather or nappa leather.







Here are some more useful items...

Genuine accessories from Mercedes-Benz

A roof spoiler is available for an even more sporty touch, for example. And if you need even more stowage space, we can recommend the XL roof box with its impressive 450-litre capacity. Left-side or right-side opening versions are available in the colours titanium metallic or matt silver.

Add the optional ski-holder insert and you can securely stow up to five pairs of skis in the XL roof box. And there are two practical ways of taking

bicycles with you, either with the New Alustyle roof-mounted bicycle rack or the rear-mounted New Alustyle carrier, which is quickly and easily attached to the trailer coupling. Both versions are able to accommodate up to three bicycles.

An iPod® Interface Kit is also available for the R-Class, designed to incorporate the miniature jukebox elegantly into the audio system. The iPod® is connected to the system inside the glove

compartment, where it is hidden from prying eyes. While on the move you can conveniently select music tracks using the multifunction steering wheel.

To find out more about the extensive range of options, have a look at our separately obtainable accessories brochure.



Very practical: the rear-mounted New Alustyle bicycle carrier is attached to the trailer coupling. A simple fold-down mechanism ensures that you still have access to the luggage compartment when needed.



Even more stowage space: the XL roof box will accommodate five pairs of skis or up to 450 litres of luggage.



For enhanced aerodynamics: the roof spoiler





Irresistibly attractive. And remarkably resistant

The extra-scratch-resistant clearcoat of the R-Class

Stars are meant to shine, therefore we have followed our tradition of doing things first and developed the best clearcoats available in the automobile market. This innovative paint system by Mercedes-Benz has made it possible to achieve another significant improvement in the high-quality visual impression and therefore the value retention of our vehicles. This clearcoat developed by Mercedes-Benz is more resistant than conventional clearcoats by virtue of its particularly dense molecular structure. It also produces a more lasting and noticeably more intense sheen. Whether you choose a metallic or non-metallic paint finish, this more scratch-resistant clearcoat is less sensitive to weathering and environmental influences, rain and snow, sunlight and temperature fluctuations. It is also more resistant to chemical attack and physical wear and tear, e.g. automatic car washes. You can rest assured that your new Mercedes will continue to shine elegantly throughout its long life.

NON-METALLIC PAINTS



040 black

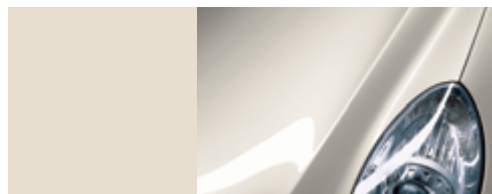

650 calcite white

METALLIC PAINTS¹

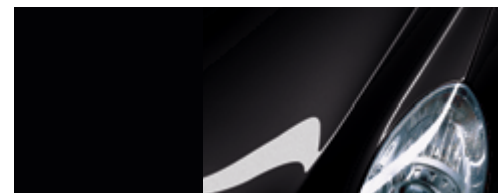

197 obsidian black



300 periclase green



359 tanzanite blue



544 carneol red

METALLIC PAINTS¹

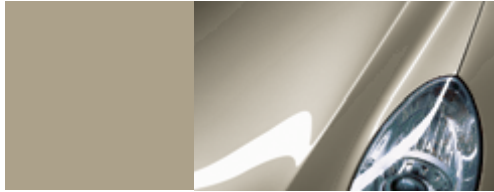

723 cubanite silver



775 iridium silver



798 sandine beige

SPECIAL PAINT FINISHES¹



112 chromite black



349 lasurite blue

¹Optional extra

ASPEN FABRIC/
ARTICO MAN-MADE LEATHER¹

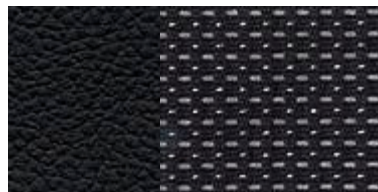

001 black

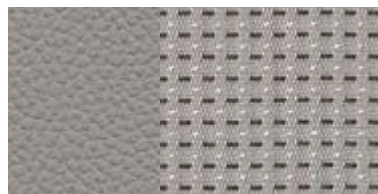

008 alpaca grey

ARTICO MAN-MADE LEATHER²

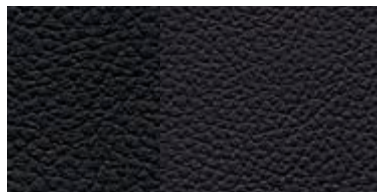

141 black



148 alpaca grey

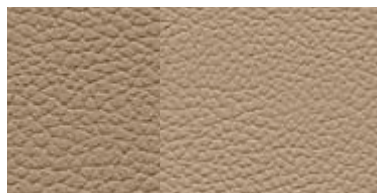

144 cashmere beige

ALCANTARA/
ARTICO MAN-MADE LEATHER
(INTERIOR SPORTS PACKAGE)

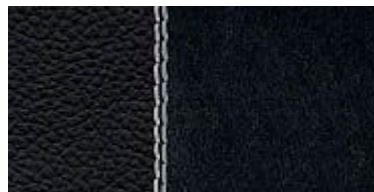

901 black



908 alpaca grey

LEATHER

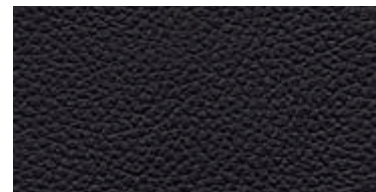

201 black

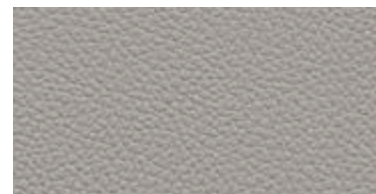

208 alpaca grey

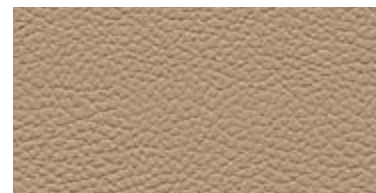

204 cashmere beige

NAPPA LEATHER



501 black



508 alpaca grey



504 cashmere beige

LEATHER,
2-TONE INTERIOR DESIGN³



258 black/alpaca grey



254 black/cashmere beige

NAPPA LEATHER,
2-TONE INTERIOR DESIGN³



558 black/alpaca grey



554 black/cashmere beige

With the R-Class, you are always impeccably dressed for every occasion – regardless of whether you choose fabric upholstery, ARTICO man-made leather, leather or even finer nappa leather. Incidentally, the feel of the materials is subjected to extensive testing by a special team in Sindelfingen in order to ensure that the surfaces are particularly pleasing to the touch. Whichever materials you choose, the colours have been carefully coordinated to match the exotic wood and sporty aluminium trim.

¹ Standard for V6 models

² Standard for R 500 4MATIC

³ Recommended with anthracite poplar wood trim



We've developed highly advanced materials for the R-Class. But the most attractive ones still come from our oldest supplier

Exceptionally fine wood elements for an exceptionally fine car

Natural wood elements make every R-Class an exclusive one-off because no two pieces of trim are identical. Nevertheless, the different types of wood we use do have one thing in common: they have all been selected with the greatest care by experts who have scoured the world in search of materials of the very highest quality. Our burr walnut, for example, is imported from California. Before the wood is ready to be fitted, our specialists subject it to a whole series of elaborate processes from which it emerges as a perfectly finished R-Class component.

Bird's-eye poplar wood trim is standard in the R 500 4MATIC, and available as an option for the V6 models. The R-Class can also be enhanced with anthracite poplar or burr walnut inserts. Aluminium trim elements are standard in the 6-cylinder models, and are also included in the interior sports package.

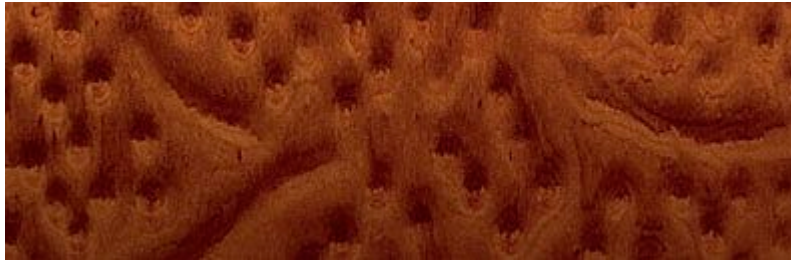

Bird's-eye poplar decor¹

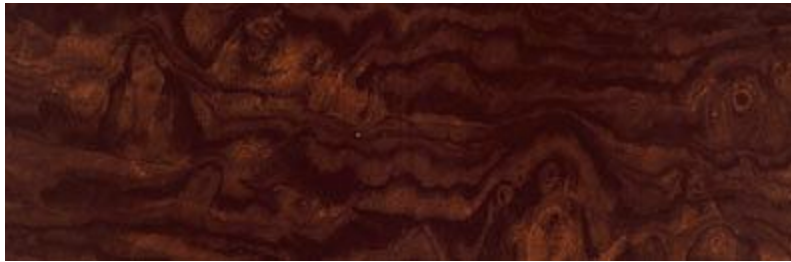

Burr walnut



Anthracite poplar²

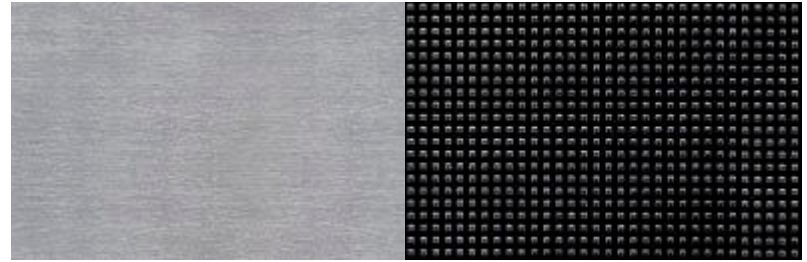

Aluminium trim elements

¹ Standard in R 500 4MATIC

² Recommended for 2-tone interior design

	<i>Aspen fabric/ ARTICO man-made leather¹</i>		<i>ARTICO man-made leather²</i>			<i>Interior sports package – Alcantara/ ARTICO man-made leather</i>		<i>Leather</i>					<i>Nappa leather</i>				
	black	alpaca grey	black	alpaca grey	cashmere beige	black	alpaca grey	black	alpaca grey	cashmere beige	black/alpaca grey ³	black/cashmere beige ³	black	alpaca grey	cashmere beige	black/alpaca grey ³	black/cashmere beige ³
NON-METALLIC PAINT																	
black	●	●	●	●	●	●	●	●	●	●	●	●	●	●	●	●	●
calcite white	●	●	●	●	○	●	●	●	●	○	●	○	●	●	○	●	○
METALLIC PAINT																	
obsidian black	●	●	●	●	●	●	●	●	●	●	●	●	●	●	●	●	●
periclase green	●	○	●	○	●	●	○	●	○	●	○	●	●	○	●	○	●
tanzanite blue	●	●	●	●	○	●	●	●	●	○	●	○	●	●	○	●	○
carneol red	●	●	●	●	●	●	●	●	●	●	●	●	●	●	●	●	●
cubanite silver	●	●	●	●	△	●	●	●	●	△	●	△	●	●	△	●	△
iridium silver	●	●	●	●	○	●	●	●	●	○	●	○	●	●	○	●	○
sanidine beige	●	△	●	△	●	●	△	●	△	●	△	●	●	△	●	△	●
SPECIAL PAINT																	
chromite black	●	●	●	●	●	●	●	●	●	●	●	●	●	●	●	●	●
lasurite blue	●	●	●	●	△	●	●	●	●	△	●	△	●	●	△	●	△

● Recommended ○ Possible △ Not recommended

¹ Standard for V6 models

² Standard for R 500 4MATIC

³ Recommended with anthracite poplar wood trim



R 500



4MATIC

D S-OG 4747

	<i>R 280 CDI</i>	<i>R 280 CDI 4MATIC¹</i>	<i>R 320 CDI 4MATIC</i>
No. of cylinders/arrangement	6/V	6/V	6/V
Bore/stroke (mm)	83/92	83/92	83/92
Total displacement (cc)	2987	2987	2987
Rated output ² (kW at rpm)	140/4000	140/4000	165/3800
Rated torque ² (Nm at rpm)	440/1400–2800	440/1400–2800	510/1600–2800
Compression ratio	17.7	17.7	17.7
Acceleration 0–100 km/h (s) (long-wheelbase version)	9.7 (9.8)	9.8	8.7 (8.8)
Top speed, approx. (km/h)	222	210	222
Tyre size	255/55 R 18	255/55 R 18	255/55 R 18
Fuel	Diesel	Diesel	Diesel
Fuel consumption ² (l/100 km) (long-wheelbase version)			
urban	11.6–11.8 (11.6–11.8)	12.2–12.4	12.2–12.4 (12.2–12.4)
extra-urban	7.5–7.7 (7.5–7.7)	7.6–7.8	7.6–7.8 (7.6–7.8)
combined	9.0–9.2 (9.0–9.2)	9.3–9.5	9.3–9.5 (9.3–9.5)
CO ₂ emissions ³ (g/km) combined (long-wheelbase version)	238–242 (238–242)	246–253	246–253 (246–253)
Tank capacity (l)/incl. reserve, approx.	80/13	80/13	80/13
Turning circle diameter (m) (long-wheelbase version)	11.7 (12.4)	11.7	11.7 (12.4)
Max. load capacity ⁴ (l) (long-wheelbase version)	2001 (2436)	2001	2001 (2436)
behind 2 nd row of seats	939 (1118)	939	939 (1118)
behind 3 rd row of seats ⁵	324 (414)	324	324 (414)
Kerb weight ⁶ (kg) (long-wheelbase version)	2195 (2245)	2250	2250 (2295)
Perm. GVW (kg) (long-wheelbase version)	2840 (2860)	2840	2840 (2895)

<i>R 280</i>	<i>R 350</i>	<i>R 350 4MATIC</i>	<i>R 500 4MATIC</i>
6/V	6/V	6/V	8/V
88/82.1	92.9/86	92.9/86	98/90.5
2996	3498	3498	5461
170/6000	200/6000	200/6000	285/6000
300/2500-5000	350/2400-5000	350/2400-5000	530/2800-4800
11.3	10.7	10.7	10.7
9.6 (9.7)	8.1 (8.2)	8.3 (8.4)	6.1 (6.3)
222	234	230	250 ⁷
255/55 R 18	255/55 R 18	255/55 R 18	255/50 R 19
Premium unleaded	Premium unleaded	Premium unleaded	Premium unleaded
14.9-15.1 (14.9-15.1)	15.4-15.6 (15.4-15.6)	15.5-15.7 (15.6-15.8)	18.2-18.4 (18.2-18.4)
8.6-8.8 (8.6-8.8)	8.6-8.8 (8.6-8.8)	9.0-9.2 (9.1-9.3)	9.8-10.0 (9.8-10.0)
10.9-11.1 (10.9-11.1)	11.1-11.3 (11.1-11.3)	11.4-11.6 (11.5-11.7)	12.9-13.1 (12.9-13.1)
260-265 (260-265)	265-270 (265-270)	271-276 (274-279)	306-311 (306-311)
80/13	80/13	80/13	80/13
11.7 (12.4)	11.7 (12.4)	11.7 (12.4)	11.7 (12.4)
2001 (2436)	2001 (2436)	2001 (2436)	2001 (2436)
939 (1118)	939 (1118)	939 (1118)	939 (1118)
324 (414)	324 (414)	324 (414)	324 (414)
2130 (2175)	2130 (2175)	2180 (2230)	2220 (2265)
2790 (2810)	2790 (2810)	2810 (2860)	2840 (2895)

¹ R 280 CDI 4MATIC is not available in long-wheelbase version

² Figures according to Directive 80/1269/EEC in the currently applicable version

³ The figures shown were obtained in accordance with the prescribed measuring process (Directive 80/1268/EEC in the currently applicable version). The figures are not based on an individual vehicle and do not constitute part of the product offer; they are provided solely for purposes of comparison between different vehicle models

⁴ Figures for vehicles with TIREFIT, loaded up to roof level

⁵ If specified as a 4+2-seater or 5+2-seater

⁶ Figures according to Directive 92/21/EC, version 95/48/EC (kerb weight with fuel tank 90 % full, driver, 68 kg, and luggage, 7 kg) for standard-specification vehicles. Optional extras and accessories will generally increase this figure and reduce the payload capacity accordingly

⁷ Electronically governed

R-Class

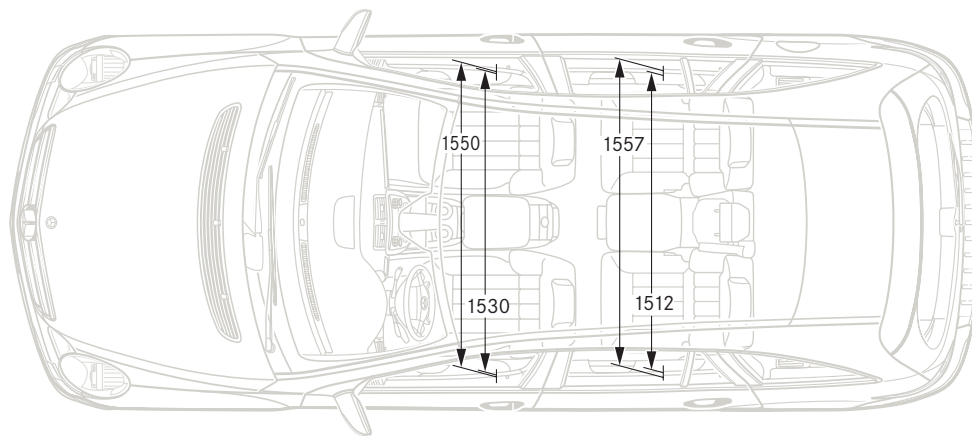
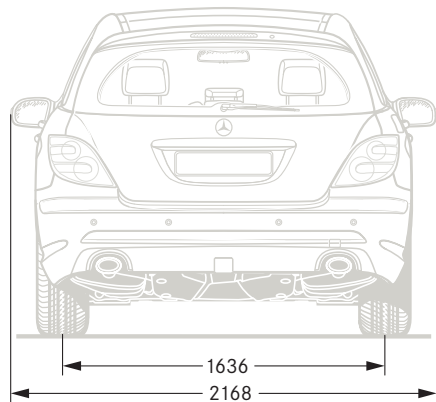
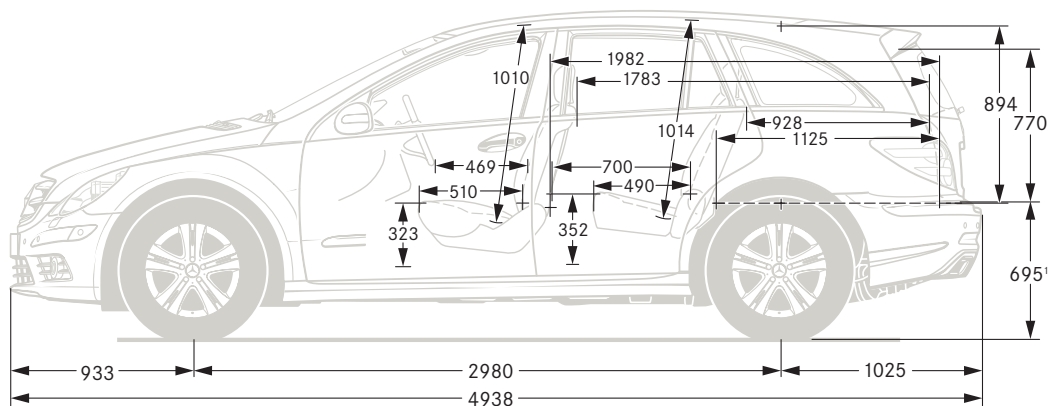
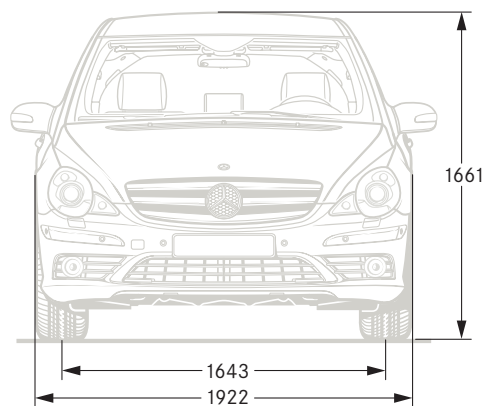

All measurements in millimetres. The dimensions shown are mean values and apply to standard-specification, unladen vehicles

¹ Carrying 4 people, each weighing 68 kg

R-Class: long-wheelbase version

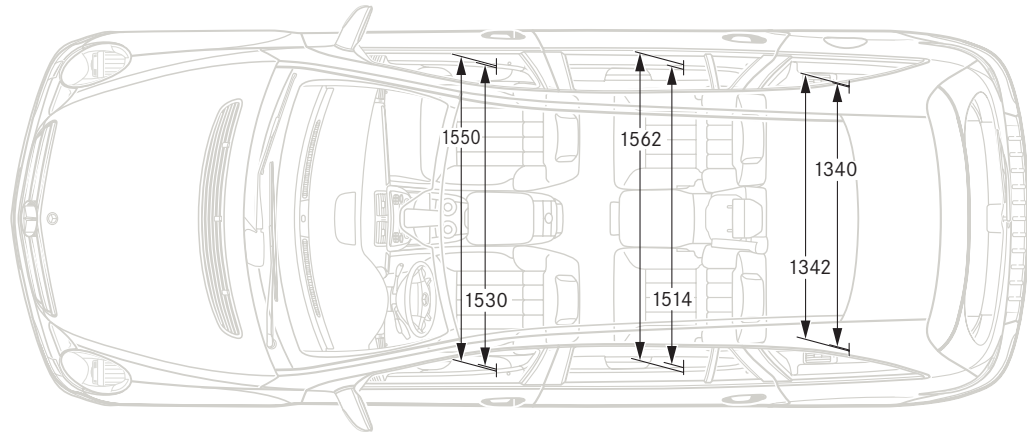
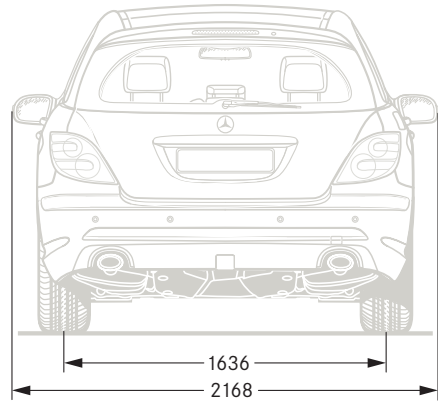
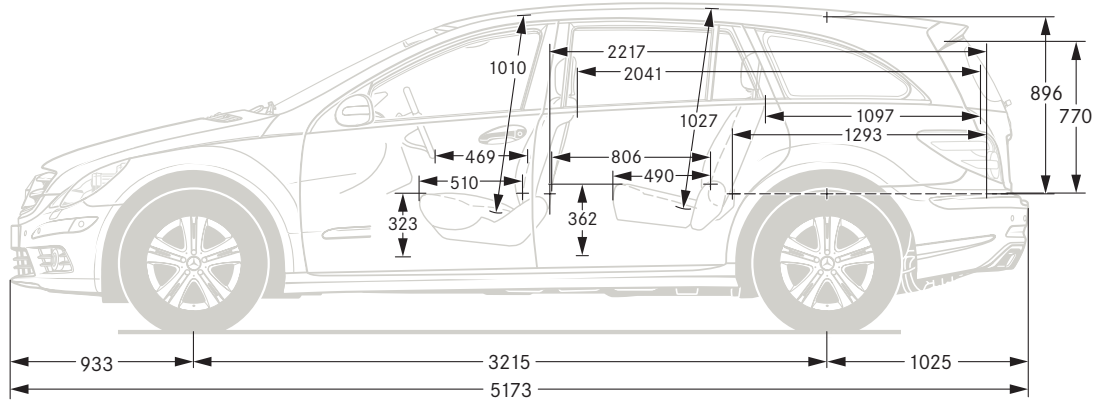
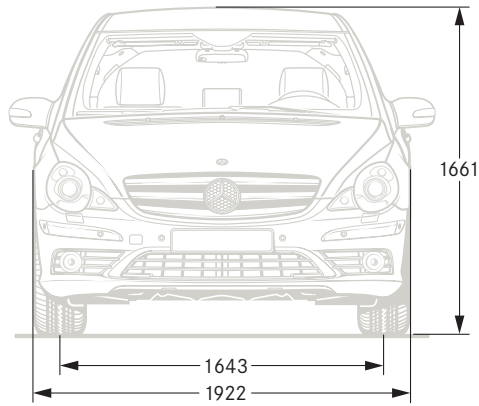

All measurements in millimetres. The dimensions shown are mean values and apply to standard-specification, unladen vehicles

The best places to go star-gazing

The world of Mercedes-Benz: our centres, dealerships, the museum and the MercedesCard

Mercedes-Benz Centres

It all started in Berlin at the end of 2000: the concept of the car dealership was reinvented with the opening of the first Mercedes-Benz Centre. Featuring the entire Mercedes-Benz model line-up as well as the accessories range, brand merchandise and an attractive programme of events, the Centres offer a welcoming environment in which to experience the brand at first hand. Now the legend surrounding the Mercedes star can be experienced at first hand in many major European cities.

And even when you're not in a large city, you are never far from the wide range of services, the comprehensive customer care and the high quality which you expect from Mercedes-Benz. A close-knit network of company branches and authorised dealers makes sure of that. You can count on their support at every stage – before, during and, most importantly, long after the purchase of your Mercedes.

Mercedes-Benz Museum

More than 120 years of automotive history brought together under one roof – that's the Mercedes-Benz Museum in Stuttgart. Waiting to whisk visitors away into a fascinating world are exhibitions covering a total of 16,500 m² of floor space. See the very

first modern-day car, the Mercedes Simplex, take a nostalgic look back at over 100 years of motorsport, and then there are our unmissable, unforgettable classics: cars such as the gull-wing and tail-fin models have earned themselves a privileged spot in the hearts of car enthusiasts and the Mercedes-Benz Museum alike.

We look forward to welcoming you.



MercedesCard

There's also a wealth of experiences to enjoy when you're not at the wheel of your Mercedes. Owning a MercedesCard is all it takes. Your ticket to the world of Mercedes-Benz also doubles as a practical credit card. Complete the annual survey and we'll even waive the card fee.

In the regular MercedesCard Journal you'll find details of attractive products as well as sporting, cultural and travel offers which have been specially selected for you. The Mercedes Magazine features interesting articles about the Mercedes-Benz brand. Your MercedesCard also gives you free entry to the Mercedes-Benz Museum. In fact the MercedesCard not only offers exciting benefits, but some very reassuring ones, too: you can protect yourself from life's less welcome surprises with Mercedes-Benz travel insurance and the MercedesCard insurance package.

Full details and application forms can be found at www.mercedes-benz.de/mercedescard

Information about the MercedesCard in Austria and Switzerland can be found on the Mercedes-Benz websites for these countries.

Have we convinced you? If you'd like to find out more, there's no substitute for a test drive

Like all our models, the R-Class offers the unique Mercedes driving experience. It's something that's communicated by even the smallest details, such as the feel of the indicator control or the solid, reassuring way the doors close. But a brochure can never do justice to qualities like these. That is why we warmly invite you to take a test drive. You can use the dealership search function at www.mercedes-benz.de, or our country-specific Internet sites, to locate your nearest Mercedes-Benz dealer who will be delighted to make all the arrangements for you.



Interactive Owner's Manual

Our website features information clips and simulations designed to help you familiarise yourself with the various functions of your car in advance. Discover the technical facts and figures and get a clear picture of a select range of functions that make driving so enjoyable. For further details, go to: www.mercedes-benz.de/betriebsanleitung

Owning a Mercedes is even more reassuring than you might think

Service 24h and the financial services offered by DaimlerChrysler Bank

24-hour service

One thing that will always accompany you in your new Mercedes is a feeling of reassurance. Because Mercedes-Benz Service24h is there for you around the clock, on 365 days of the year. In the very unlikely event of a technical breakdown or starting problem anywhere in Europe, you can rely on round-the-clock assistance from Mercedes-Benz Service24h. Simply phone our Service hotline on 00800 1 777 7777*, where our specialists will immediately organise fast, professional assistance. Anytime, on 365 days of the year, 7 days a week and around the clock. As soon as your call is received, a member of our Service24h team will be dispatched to your location. Often the problem can be rectified on the spot, but if this is not possible, we will naturally ensure that your vehicle is taken to the nearest Mercedes-Benz workshop and get you back on the road as quickly as possible.

*In non-affiliated European countries: +49 69 95 30 72 77

DaimlerChrysler Bank

If you have already set your heart on your dream Mercedes and want to remain flexible in financial terms, our financial services can turn your dream into reality. Whether you are looking for leasing, financing, insurance or service packages, we can provide them all. The online calculator makes it easy for you to work out your monthly payments.

In addition to individually geared financial services, we can also offer you attractive investment products, such as a call account, fixed-income investments or portfolio funds. More information is available by phone on 0 18 03-DC BANK or 0 18 03-32 2265 (calls charged at 9 euro cents per minute) or by visiting www.daimlerchrysler-bank.de

Take-back of end-of-life vehicles. Coming full circle

At the end of its long life, you can return your R-Class to us for environment-friendly disposal in accordance with the EC End-Of-Life Vehicle Directive¹. But that day lies a long way off.

¹Applies in accordance with national regulations to vehicles up to 3.5 tonnes gross weight. Mercedes-Benz passenger cars have met the statutory regulations governing the suitability of their design for reuse and recycling for a number of years now. A network of vehicle take-back depots and dismantlers has been established which will process your vehicle in an environment-friendly manner. The ways in which both vehicles and parts can be recovered are subject to ongoing development and improvement. Consequently, the R-Class will be able to comply with any future increases in the recycling quota within the stipulated time limits. Further information can be obtained by calling 00800 1 777 7777.

Please note: changes may have been made to the product since this brochure went to press (30.06.2007). The manufacturer reserves the right to make changes to the design, form, colour and specification during the delivery period, provided these changes, while taking into account the interests of the vendor, can be deemed reasonable with respect to the purchaser. Where the vendor or the manufacturer uses symbols or numbers to describe an order or the subject of an order, no rights may be derived solely from these. The illustrations may show accessories and items of optional equipment which are not part of standard specification. Colours may differ slightly from those shown in the brochure, owing to the limitations of the printing process. This brochure has been compiled by DaimlerChrysler AG of Germany and is distributed internationally. It provides a general indication of the range of models, features, optional extras and/or colours available in various countries. Some of the models, features, optional extras and/or colours may not be available in your country, or may only be available in a different specification. Additionally some models, features, optional extras and/or colours may only be available in combination with others. For current and more specific information in relation to the range of models, features, optional extras and/or colours available in your country, and their pricing, you should contact your nearest authorised Mercedes-Benz Passenger Car Dealer.