

Application examples of the KLANN modular system

3

➤ Drive-Shaft extraction

With the **KL-0174-series** Puller
Extraction of Loctited Drive-Shafts may be easily accomplished by using the optional Hydraulic Spindle **KL-0045-7** (12t.) or the Hydraulic Cylinder **KL-0215-10** (17t.)



➤ Removal of wheel-bearing inner-races from the hub

By use of the **KL-0042-90** with appropriate chucks.



➤ Wheel hub extraction

with the tool **KL-0041-38**. Due to the hydraulic cylinder (17 t.) **KL-0040-2500** even very stuck or glued wheel hubs can be removed without problems.



➤ Wheel hub bearing unit insertion

by using the KLANN wheel bearing tool set.



Chapter 3 overview

3.1 Wheel Bearings

Page 3.1-01 - 3.1-12



3.2 Wheel Hub Bearing units

Page 3.2-01 - 3.2-04



3.3 Wheel Hubs

Page 3.3-01 - 3.3-09



3.4 Drive shafts

Page 3.4-01 - 3.4-05



3.5 Wheels

Page 3.5-01 - 3.5-05



The new KLANN Wheel Bearing/Bush Tool KL-0039-Series !!!!!

The big advantages of the new and unique bearing/bush tools are:

- Modular system provided with a versatile hydraulic drive (KL-0040-2500), two adaptors and universally combinable centring and pressure rings as well as pressure and support sleeves.
- Universal field of application.
- Huge time and cost savings due to the easy assembling of the required tool.

Application example: *Wheel bearing extraction.*

1. Configuration of the required pieces and tool assembling:

Measure inner-/outer-Ø, identify pressure and centring rings. (see table page 3.1-03)

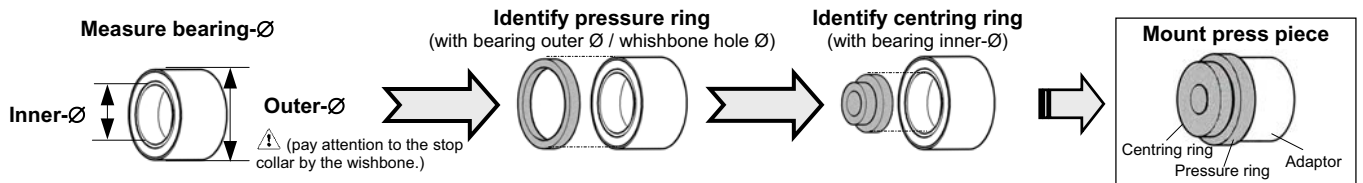

2. Mount the tool on the wishbone and extract wheel bearing.

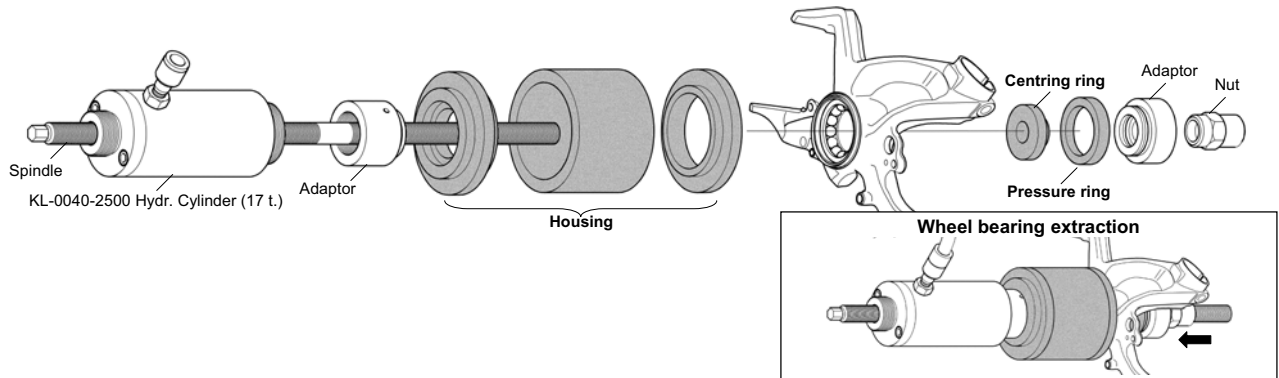

Application example: *Wheel Bearing insertion.*

1. Configuration of the required pieces and tool assembling:

Measure inner-/outer-Ø, identify pressure and centring ring (wheel bearing), identify pressure ring (wheel bearing housing support) (see table page 3.1-03)

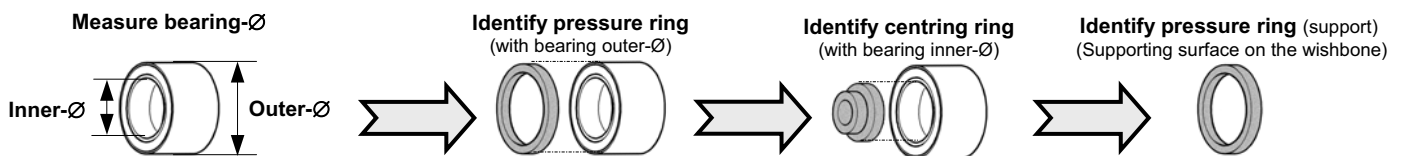

2. Mount the tool on the wishbone and press the wheel bearing in.

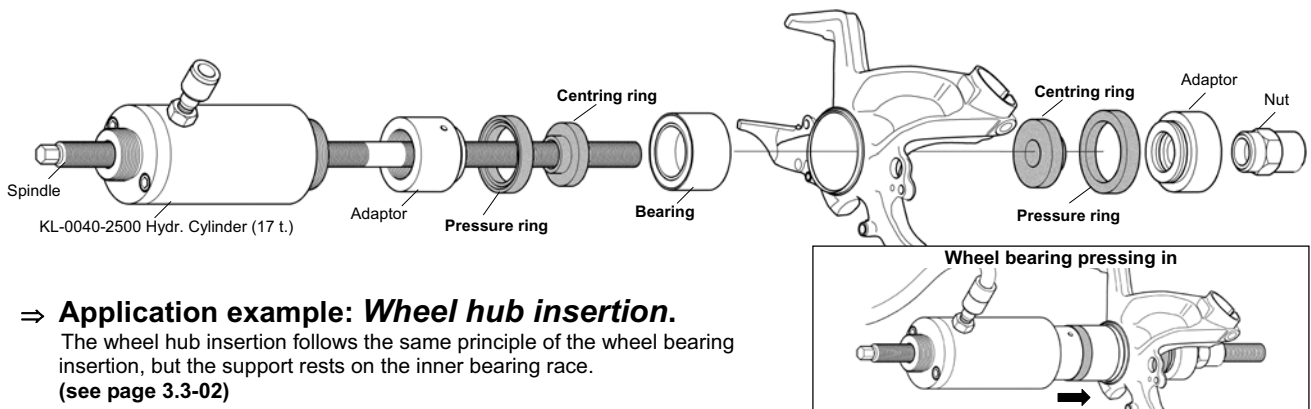

⇒ Application example: *Wheel hub insertion.*

The wheel hub insertion follows the same principle of the wheel bearing insertion, but the support rests on the inner bearing race. (see page 3.3-02)

Note: The hydraulic cylinder KL-0040-2500 shall be operated by a hydraulic pump. See page 4-08.

The new KLANN Wheel Bearing/Bush Tool KL-0039-Series !!!!!

3

Application example: *Bush extraction / insertion by using a Puller Spindle.*

1. Configuration of the required pieces and tool assembling:

Measure bush-Ø, identify spindle, pressure and support sleeve. (See table page 3.1-03, 3.1-04)

Measure bearing-Ø and bore-Ø.

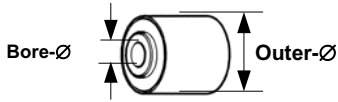

Identify support sleeve (with outer-Ø measure)

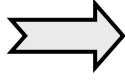

(Support sleeve -Ø = BushA.-Ø + approx. 10%)

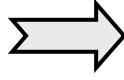

Identify pressure sleeve (with outer-Ø measure)

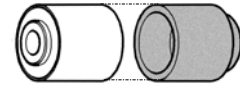

(Pressure sleeves o.-Ø = Bush o.-Ø)

2. Mount the tool and extract the bush. (The insertion follows the same principle)

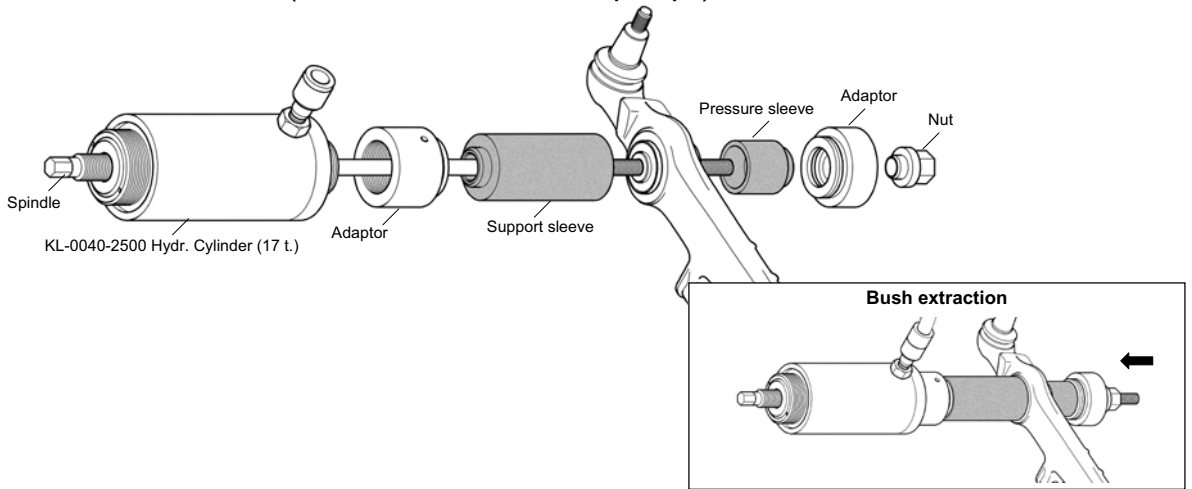

Application example: *Ball Joint / Bush extraction / insertion with Press Frame.*

1. Configuration of the required pieces and tool assembling:

Measure the bush outer-Ø, identify pressure and support sleeve. (See table page 3.1-03, 3.1-04)

Measure bearing-Ø.

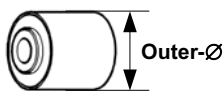

Identify support sleeve (with outer-Ø measure)

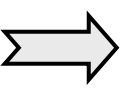

(Support sleeve i.-Ø = Bush o.-Ø + approx. 10%)

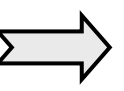

Identify pressure sleeve (with outer-Ø measure)

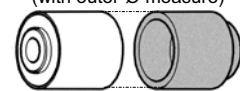

(Pressure sleeve o.-Ø = Bush o.-Ø)

2. Mount the tool and press the ball joint out. (The insertion follows the same principle)

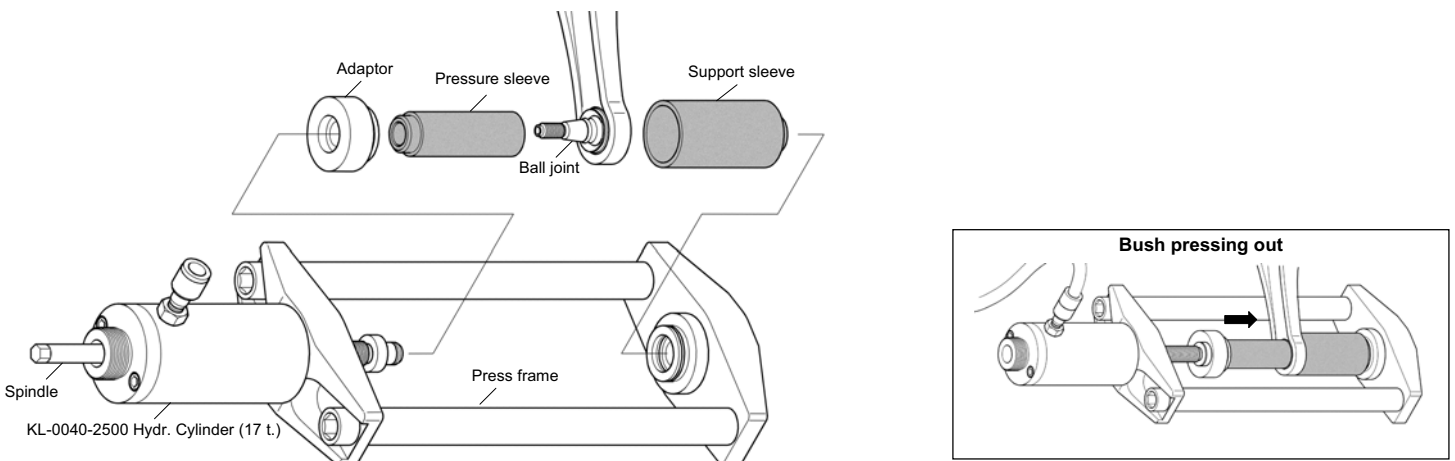

Note: The hydraulic cylinder KL-0040-2500 shall be operated by a hydraulic pump. See page 4-08.

KL-0039- Series Wheel Bearing/ Silent Block Tool

3

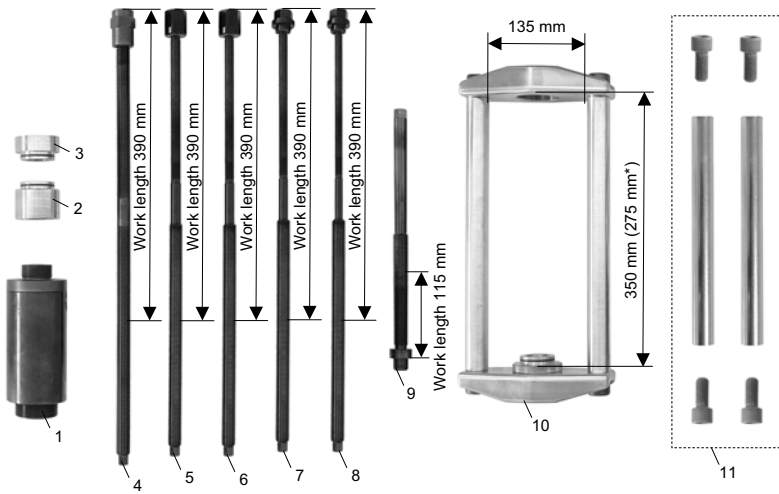

Drive and base pieces

Pos.	Part No.	Description	Qty.
Cylinder:			
1	KL-0040-2500	Hydraulic cylinder 17 t	1
Adaptor:			
2	KL-0039-1003	Retain adaptor for hydraulic cylinder	1
3	KL-0039-1002	Retain adaptor for Nut M20	1
Spindles:			
4	KL-0039-1920	Spindle M20 with clamping nut	1
5	KL-0039-1916	Spindle M16 with shoulder nut	1
6	KL-0039-1914	Spindle M14 with shoulder nut	1
7	KL-0039-1912	Spindle M12 with shoulder nut	1
8	KL-0039-1910	Spindle M10x1.25 with shoulder nut	1
9	KL-0039-1930	Pressure Spindle	1
Press Frame:			
10	KL-0039-1130	Press frame	1
Accessory:			
11	KL-0039-111	Frame rods 285 mm long	1

* If using the frame rods KL-0039-111.

Application pieces ⇒ Wheel Bearing

Pressure rings:

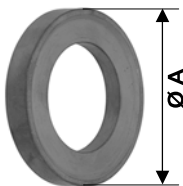

KL-0039-120 Pressure ring set Ø 54 - 90 mm (Inner-Ø 46 mm):

Part No.	Description	Ø A
KL-0039-1254	Pressure ring Ø54	Ø54
KL-0039-1260	Pressure ring Ø60	Ø60
KL-0039-1261	Pressure ring Ø61	Ø61
KL-0039-1262	Pressure ring Ø62	Ø62
KL-0039-1263	Pressure ring Ø63	Ø63
KL-0039-1264	Pressure ring Ø64	Ø64
KL-0039-1265	Pressure ring Ø65	Ø65
KL-0039-1266	Pressure ring Ø66	Ø66
KL-0039-1267	Pressure ring Ø67	Ø67
KL-0039-1268	Pressure ring Ø68	Ø68
KL-0039-1269	Pressure ring Ø69	Ø69
Accessory:		
KL-0039-1502	Pressure ring Ø93	Ø93

Part No.	Description	Ø A
KL-0039-1270	Pressure ring Ø70	Ø70
KL-0039-1271	Pressure ring Ø71	Ø71
KL-0039-1272	Pressure ring Ø72	Ø72
KL-0039-1273	Pressure ring Ø73	Ø73
KL-0039-1274	Pressure ring Ø74	Ø74
KL-0039-1275	Pressure ring Ø75	Ø75
KL-0039-1276	Pressure ring Ø76	Ø76
KL-0039-1277	Pressure ring Ø77	Ø77
KL-0039-1278	Pressure ring Ø78	Ø78
KL-0039-1279	Pressure ring Ø79	Ø79
KL-0039-1280	Pressure ring Ø80	Ø80

Part No.	Description	Ø A
KL-0039-1281	Pressure ring Ø81	Ø81
KL-0039-1282	Pressure ring Ø82	Ø82
KL-0039-1283	Pressure ring Ø83	Ø83
KL-0039-1284	Pressure ring Ø84	Ø84
KL-0039-1285	Pressure ring Ø85	Ø85
KL-0039-1286	Pressure ring Ø86	Ø86
KL-0039-1287	Pressure ring Ø87	Ø87
KL-0039-1288	Pressure ring Ø88	Ø88
KL-0039-1289	Pressure ring Ø89	Ø89
KL-0039-1290	Pressure ring Ø90	Ø90

Centring rings:

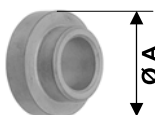

KL-0039-130 Centring ring set Ø 25 - 60 mm:

Part No.	Description	Ø A
KL-0039-1325	Centring ring Ø25	Ø25
KL-0039-1326	Centring ring Ø26	Ø26
KL-0039-1327	Centring ring Ø27	Ø27
KL-0039-1328	Centring ring Ø28	Ø28
KL-0039-1329	Centring ring Ø29	Ø29
KL-0039-1330	Centring ring Ø30	Ø30
KL-0039-1331	Centring ring Ø31	Ø31
KL-0039-1332	Centring ring Ø32	Ø32
KL-0039-1333	Centring ring Ø33	Ø33
KL-0039-1334	Centring ring Ø34	Ø34
KL-0039-1335	Centring ring Ø35	Ø35
KL-0039-1336	Centring ring Ø36	Ø36

Part No.	Description	Ø A
KL-0039-1337	Centring ring Ø37	Ø37
KL-0039-1338	Centring ring Ø38	Ø38
KL-0039-1339	Centring ring Ø39	Ø39
KL-0039-1340	Centring ring Ø40	Ø40
KL-0039-1341	Centring ring Ø41	Ø41
KL-0039-1342	Centring ring Ø42	Ø42
KL-0039-1343	Centring ring Ø43	Ø43
KL-0039-1344	Centring ring Ø44	Ø44
KL-0039-1345	Centring ring Ø45	Ø45
KL-0039-1346	Centring ring Ø46	Ø46
KL-0039-1347	Centring ring Ø47	Ø47
KL-0039-1348	Centring ring Ø48	Ø48

Part No.	Description	Ø A
KL-0039-1349	Centring ring Ø49	Ø49
KL-0039-1350	Centring ring Ø50	Ø50
KL-0039-1351	Centring ring Ø51	Ø51
KL-0039-1352	Centring ring Ø52	Ø52
KL-0039-1353	Centring ring Ø53	Ø53
KL-0039-1354	Centring ring Ø54	Ø54
KL-0039-1355	Centring ring Ø55	Ø55
KL-0039-1356	Centring ring Ø56	Ø56
KL-0039-1357	Centring ring Ø57	Ø57
KL-0039-1358	Centring ring Ø58	Ø58
KL-0039-1359	Centring ring Ø59	Ø59
KL-0039-1360	Centring ring Ø60	Ø60

KL-0039-140 Housing set (bearing extension):

Bearing cap:		Housing:		Centring rings:	
Part No.	Description	Part No.	Description	Part No.	Description
KL-0039-1401	Bearing cap Ø A1: 84 / Ø A2: 90	KL-0039-1402	Housing Ø A1: 84 / Ø A2: 90	KL-0039-1413	Centring ring Ø A: 70
				KL-0039-1414	Centring ring Ø A: 75

Special plates:

Part No.	Description
KL-0039-1503	Adaptor ring conical
KL-0039-1504	Adaptor ring conical
KL-0039-1505	Adaptor ring cylindric

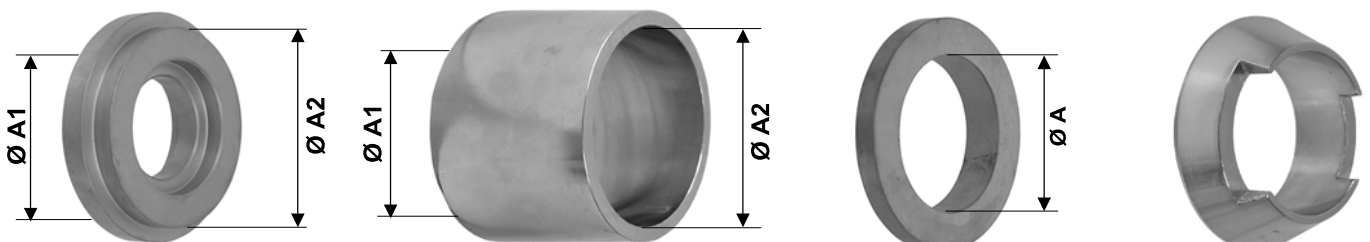

KL-0039- Series Wheel Bearing / Silent Block Tool

Application pieces ⇒ **Silent Block**

Press/Support Tube Type 1:

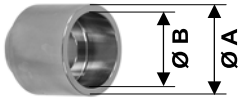

KL-0039-160 Press/Support Tube Set Ø30 - 90mm Type 1 (Length: 45 mm):

Part No.	Description	Ø A	Ø B	Part No.	Description	Ø A	Ø B
KL-0039-1630	Press/Support Tube short Ø30	Ø30	Ø22	KL-0039-1642	Press/Support Tube short Ø42	Ø42	Ø34
KL-0039-1632	Press/Support Tube short Ø32	Ø32	Ø24	KL-0039-1644	Press/Support Tube short Ø44	Ø44	Ø36
KL-0039-1634	Press/Support Tube short Ø34	Ø34	Ø26	KL-0039-1646	Press/Support Tube short Ø46	Ø46	Ø38
KL-0039-1636	Press/Support Tube short Ø36	Ø36	Ø28	KL-0039-1648	Press/Support Tube short Ø48	Ø48	Ø40
KL-0039-1638	Press/Support Tube short Ø38	Ø38	Ø30	KL-0039-1650	Press/Support Tube short Ø50	Ø50	Ø42
KL-0039-1640	Press/Support Tube short Ø40	Ø40	Ø32	KL-0039-1652	Press/Support Tube short Ø52	Ø52	Ø44

Part No.	Description	Ø A	Ø B	Part No.	Description	Ø A	Ø B
KL-0039-1654	Press/Support Tube short Ø54	Ø54	Ø46	KL-0039-1674	Press/Support Tube short Ø74	Ø74	Ø66
KL-0039-1656	Press/Support Tube short Ø56	Ø56	Ø48	KL-0039-1676	Press/Support Tube short Ø76	Ø76	Ø68
KL-0039-1658	Press/Support Tube short Ø58	Ø58	Ø50	KL-0039-1678	Press/Support Tube short Ø78	Ø78	Ø70
KL-0039-1660	Press/Support Tube short Ø60	Ø60	Ø52	KL-0039-1680	Press/Support Tube short Ø80	Ø80	Ø72
KL-0039-1662	Press/Support Tube short Ø62	Ø62	Ø54	KL-0039-1682	Press/Support Tube short Ø82	Ø82	Ø74
KL-0039-1664	Press/Support Tube short Ø64	Ø64	Ø56	KL-0039-1684	Press/Support Tube short Ø84	Ø84	Ø76
KL-0039-1666	Press/Support Tube short Ø66	Ø66	Ø58	KL-0039-1686	Press/Support Tube short Ø86	Ø86	Ø78
KL-0039-1668	Press/Support Tube short Ø68	Ø68	Ø60	KL-0039-1688	Press/Support Tube short Ø88	Ø88	Ø80
KL-0039-1670	Press/Support Tube short Ø70	Ø70	Ø62	KL-0039-1690	Press/Support Tube short Ø90	Ø90	Ø82
KL-0039-1672	Press/Support Tube short Ø72	Ø72	Ø64				

Press/Support Tube Type 2:

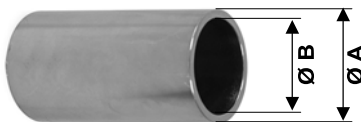

KL-0039-170 Press/Support Tube Set Ø30 - 90mm Type 2 (Length: 115 mm):

Part No.	Description	Ø A	Ø B	Part No.	Description	Ø A	Ø B
KL-0039-1730	Press/Support Tube long Ø30	Ø30	Ø22	KL-0039-1742	Press/Support Tube long Ø42	Ø42	Ø34
KL-0039-1732	Press/Support Tube long Ø32	Ø32	Ø24	KL-0039-1744	Press/Support Tube long Ø44	Ø44	Ø36
KL-0039-1734	Press/Support Tube long Ø34	Ø34	Ø26	KL-0039-1746	Press/Support Tube long Ø46	Ø46	Ø38
KL-0039-1736	Press/Support Tube long Ø36	Ø36	Ø28	KL-0039-1748	Press/Support Tube long Ø48	Ø48	Ø40
KL-0039-1738	Press/Support Tube long Ø38	Ø38	Ø30	KL-0039-1750	Press/Support Tube long Ø50	Ø50	Ø42
KL-0039-1740	Press/Support Tube long Ø40	Ø40	Ø32	KL-0039-1752	Press/Support Tube long Ø52	Ø52	Ø44

Part No.	Description	Ø A	Ø B	Part No.	Description	Ø A	Ø B
KL-0039-1754	Press/Support Tube long Ø54	Ø54	Ø46	KL-0039-1774	Press/Support Tube long Ø74	Ø74	Ø66
KL-0039-1756	Press/Support Tube long Ø56	Ø56	Ø48	KL-0039-1776	Press/Support Tube long Ø76	Ø76	Ø68
KL-0039-1758	Press/Support Tube long Ø58	Ø58	Ø50	KL-0039-1778	Press/Support Tube long Ø78	Ø78	Ø70
KL-0039-1760	Press/Support Tube long Ø60	Ø60	Ø52	KL-0039-1780	Press/Support Tube long Ø80	Ø80	Ø72
KL-0039-1762	Press/Support Tube long Ø62	Ø62	Ø54	KL-0039-1782	Press/Support Tube long Ø82	Ø82	Ø74
KL-0039-1764	Press/Support Tube long Ø64	Ø64	Ø56	KL-0039-1784	Press/Support Tube long Ø84	Ø84	Ø76
KL-0039-1766	Press/Support Tube long Ø66	Ø66	Ø58	KL-0039-1786	Press/Support Tube long Ø86	Ø86	Ø78
KL-0039-1768	Press/Support Tube long Ø68	Ø68	Ø60	KL-0039-1788	Press/Support Tube long Ø88	Ø88	Ø80
KL-0039-1770	Press/Support Tube long Ø70	Ø70	Ø62	KL-0039-1790	Press/Support Tube long Ø90	Ø90	Ø82
KL-0039-1772	Press/Support Tube long Ø72	Ø72	Ø64				

Note:

For further information order single brochure!

Accessories

Part No.	Description	Ø A	Ø B	Part No.	Description	Ø A	Ø B
KL-0039-1802	Centring tube long Ø27.5	Ø27.5	Ø20.5	KL-0039-1803	Centring tube long Ø29.7	Ø29.5	Ø22

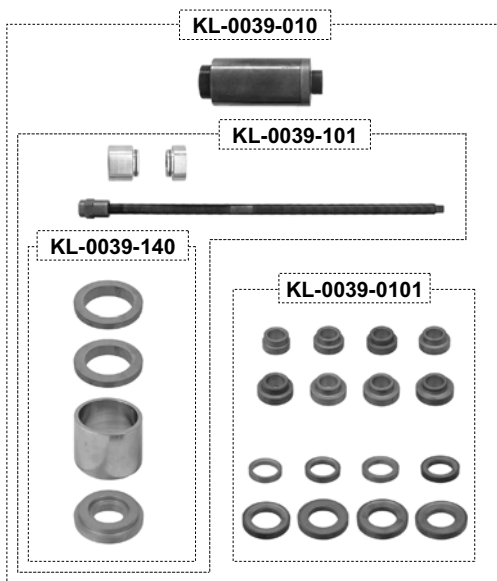

KL-0039-010 Wheel Bearing Puller Tool Set with hydr. cylinder 17 t.

Suitable for VW-Audi, BMW, Ford, Seat, Skoda, Opel etc.

This tool set allows a quick, precise and safe wheel bearing removal and installation. Very stubborn or rusted wheel bearings are easily extracted with the tool set **KL-0039-0100**.

This tool set can be integrated with other components of the **KL-0039-.. Series** as e.g. centering rings, thrust pads, pressure and support sleeves in order to make the wheel bearing puller almost universal in its range of application (e.g. also suitable for ball joints or bushes replacement).

Specification:

Part No.	Consists of: (Tool sets are marked fat)
KL-0039-010	KL-0040-2500, KL-0039-101 , KL-0039-0101
KL-0039-101	KL-0039-1003, KL-0039-1002, KL-0039-1920, KL-0039-140
KL-0039-140	KL-0039-1401, KL-0039-1402, KL-0039-1413, KL-0039-1414
KL-0039-0101	KL-0039-1260, KL-0039-1264, KL-0039-1268, KL-0039-1272, KL-0039-1274, KL-0039-1280, KL-0039-1282, KL-0039-1285, KL-0039-1334, KL-0039-1338, KL-0039-1339, KL-0039-1340, KL-0039-1341, KL-0039-1342, KL-0039-1343, KL-0039-1345

KL-0040-31 D

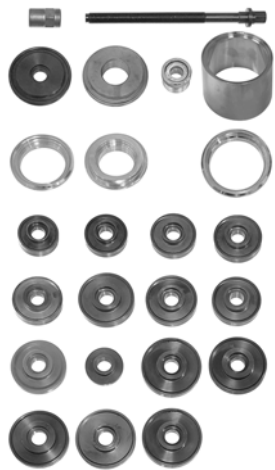

VW-Audi, Ford, Opel, Seat, Škoda



KL-0040-31 D Wheel Bearing Puller

Suitable for VW - Audi, Ford, Opel, Seat and Škoda e.g. Audi A3, A4, A6; VW Golf IV, Passat, Sharan, T4 etc.

The use of further pressure pieces makes it also suitable for BMW, Fiat, Citroën, Mercedes, Peugeot, Renault and Japanese vehicles.

This tool set allows the quick and correct replacement of wheel bearings on built-in axle without damaging the new wheel bearing.

Time savings: More than one hour for each wheel bearing.

Composition: see page 3.1-05

KL-0040-3 K



KL-0040-3 K Wheel Bearing Puller

Includes the Set **KL-0040-3** and the Case **KL-0040-3021** (450 x 365 x 140 mm).

Composition: see Page 3.1-05

Application: VW-Audi, Opel, Fiat, Seat, Mercedes, Peugeot, Citroën, Renault and Ford.

KL-0040-5 H



KL-0040-5 H Wheel Bearing Puller

Consists of all parts listed in the Table on page 3.1-05 and the Storage Tray **KL-0040-0050** (750 x 440 x 40 mm).

Application: VW-Audi, Opel, Fiat, Seat, Mercedes, Peugeot, Citroën, Renault, Ford, Honda, Rover, Mazda, Mitsubishi, Nissan, Toyota and Austin Maestro.

KL-0040-51 K



KL-0040-51 K Wheel Bearing Puller

Consists of all parts listed in the Table on page 3.1-05, the Pairs of Press Bolts **KL-0105**, **KL-0106**, **KL-0107** and Plastic Case with roller-wheels (780 x 450 x 175 mm).

Universal application.

KL-0040-25



Universal

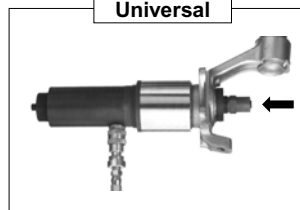

Note:

An hydraulic pump (see Chapter 4) will be required to drive the **KL-0040-2500**

KL-0040-25 Hydraulic-Cylinder (17 t)

With Pulling Spindle KL-0040-2512.

When the bearing is seized in the bearing housing, it is necessary to pull the bearing out or to pull it in with the hydraulic cylinder **KL-0040-25** in conjunction e.g. with **KL-0040-3**. As the mechanic spindle is overloaded due to pulling force.

(The hydraulic cylinder is supplied without coupling).

Note: Technical information and further hydraulic accessories are available at Chapter 4.

KL-0040-61 A

Mercedes



Wheel hub extraction with **KL-0330-12**
(see page 3.3-03)

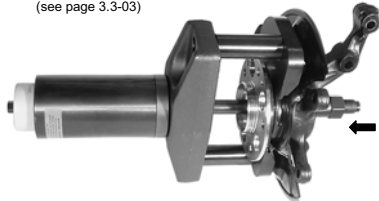

Wheel bearing extraction with **KL-0040-61 A**



Inner racer extraction with **KL-0042-92**
(see page 3.3-08)

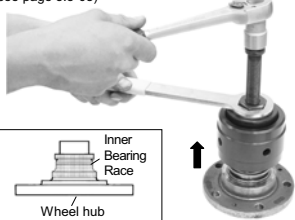

Wheel bearing pull in with **KL-0040-61 A**

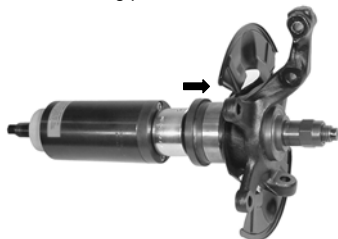

Wheel hub pull in with **KL-0040-61 A**

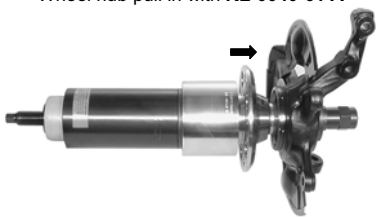

KL-0040-61 A Wheel Bearing Puller Tool Set

Suitable for Mercedes:

W124, W129, W140, W163, W168, W169, W201, W202, W203, W210, W211, W245 and W638.

At last, an hydraulic Wheel Bearing Tool has been launched which covers all Mercedes passenger cars fitted with cassette wheel-bearings.

Removal and replacement of the wheel bearing is performed on the vehicle within a few minutes.

Assembly of the Hub uses the same tool.

- Removal of the Hub requires the newly-developed **KL-0330-12 (or KL-0330-121)** Hub Extractor. (see Page 6).

Note:

- Wheel bearing puller tool set **KL-0040-61 A** is based on tool set **KL-0040-61** together with No. 4 centring disc **KL-0040-3046**. The range of applications now includes the new Mercedes **A Class (W169)** and **B Class (W245)**.
- On the Mercedes **E Class (W211)** a bolted bearing is installed at the rear axle. In this case, tool set **KL-0040-61** or **KL-0040-61 A** and wheel hub puller **KL-0330-12** will be needed for **removal and installation of the wheel hub**.

Advantages:

- ⇒ The wheel bearing tool is universal in its applications.
- ⇒ The tool set can also be used on other vehicles if additional thrust blocks are obtained.
- ⇒ All spare parts can also be obtained individually.
- ⇒ Wheel bearings can be replaced accurately **on the vehicle** within just a few minutes.
- ⇒ Hollow-piston hydraulic cylinder **KL-0040-2500** can be used to remove and install propeller shafts, wheel hubs, support joints and silentbloc-type bushings.

KL-0040-610 A Wheel Bearing Puller Tool Set (without hydr. Drive)

As **KL-0040-61 A**.

if Hydraulic Cylinder **KL-0040-2500**, the Adaptor **KL-0040-2551**, the Spindle **KL-0040-2512** and the Nut **KL-0040-3009** are already available.

Contents:

Part No.	Description	Qty.
KL-0040-610 A	Wheel Bearing Puller Tool Set (without hydr. Drive)	1
<i>consists of:</i>		
KL-0040-6101	Housing	1
KL-0040-6102	Support ring	1
KL-0040-6103	Centring Disc	1
KL-0040-6104	Pressure Disc	1
KL-0040-6105	Pressure Disc	1
KL-0040-6106	Pressure Disc	1
KL-0040-3012	Pressure Disc No. 1	1
KL-0040-3039	Pressure Disc No. 20	1
KL-0040-3046	Centring Disc No. 4	1

KL-0040-84 A

Peugeot, Fiat

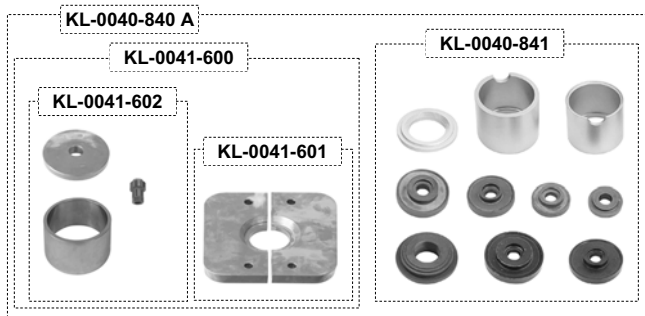

Wheel hub extraction

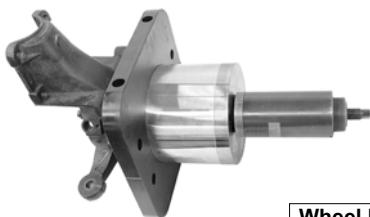

Wheel bearing extraction



Wheel hub pull in

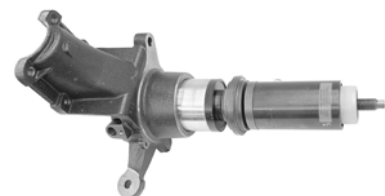

Wheel bearing pull in

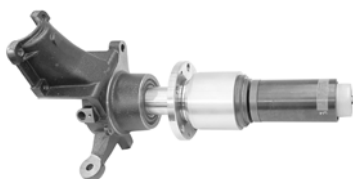

Note: To drive the hydraulic cylinder KL-0040-2500 a hydraulic pump (see chapter 4) necessary.

KL-0040-84 A Wheel Bearing / Hub Puller with hydraulic cylinder (17 t.)

Suitable for Peugeot Boxer II and Fiat Ducato ('02 onwards) Wheel Bearings with the diameters:

outer-Ø 84 mm / inner Ø 49 mm or
outer-Ø 90 mm / inner Ø 55 mm.

Application:

For removing and installing the wheel hub and for fast and correct replacement of the wheel bearing avoiding damages, without the need to remove the axle.

Time savings: more than one hour for each wheel bearing.

The Wheel Bearing Puller **KL-0041-841** in combination with the hydraulic cylinder **KL-0040-2500**, the Spindle **KL-0040-2512** and the Nut **KL-0040-3009** allows removing the hub correctly with a force up to 17 tons.

Very stubborn wheel hubs may be pressed out under a bench press in combination with the chuck jaws **KL-0041-601**.

Note:

It has been experienced, that for pressing out the wheel hub on some cars forces up to 40 tons may be required.

Specification:

Part No.	Description	Qty.
KL-0040-84 A	Wheel Bearing / Hub Puller with hydraulic cylinder (17 t.)	1
<i>consists of:</i>		
KL-0040-2500	Hydraulic Cylinder (17 t.)	1
KL-0040-2512	Spindle M 20	1
KL-0040-3009	Nut M 20	1
KL-0040-840 A	Wheel Bearing / Hub Puller without Drive	1

Part No.	Description	Qty.
KL-0040-840 A	Wheel Bearing / Hub Puller without hydraulic cylinder	1
<i>consists of:</i>		
KL-0041-600	Hub Puller without Drive	1
KL-0040-841	Wheel Bearing Puller without Drive	1

Part No.	Description	Qty.
KL-0041-600	Hub Puller without Drive	1
<i>consists of:</i>		
KL-0041-601	Chuck jaw pair	1
KL-0041-602	Update Kit	1

Part No.	Description	Qty.
KL-0040-841	Wheel Bearing Puller without Drive	1
<i>consists of:</i>		
KL-0040-3002	Bearing housing	1
KL-0040-3030	Adaptor disc	1
KL-0040-3032	Housing	1
KL-0040-3037	Pressure disc Nr. 18	1
KL-0040-3039	Pressure disc Nr. 20	1
KL-0040-3045	Pressure disc Nr. 23	1
KL-0040-3047	Stepper ring Nr. 7	1
KL-0040-3048	Housing	1
KL-0040-3049	Pressure disc Nr. 24	1
KL-0040-3050	Pressure disc Nr. 25	1

KL-0040-80

Renault Master
Opel Movano



KL-0040-801



KL-0040-800



Wheel hub extraction

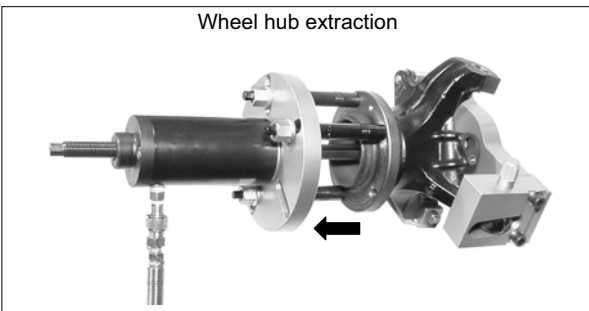

New wheel bearing insertion

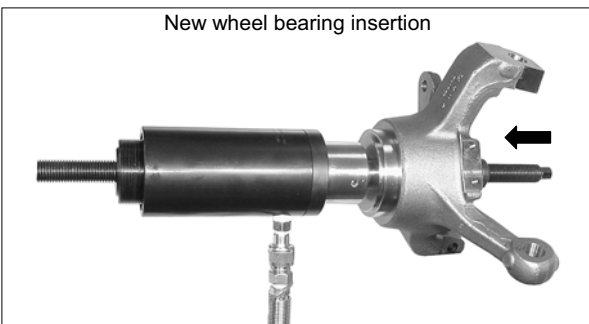

KL-0040-80 Wheel Bearing Puller Opel Movano, Renault Master

Suitable for:

Opel Movano / Renault Master October 1997 - Jan. 2001
Opel Movano / Renault Master onwards January 2001

⇒ Drive Shaft extraction.

⇒ Hub extraction and replacement.

⇒ Wheel Bearing extraction and replacement.

The special design of this new Wheel Bearing Tool allows stubborn Drive Shafts, Wheel Hubs and Bearings to be extracted and inserted hydraulically.

It makes no difference if the brake disc is mounted on the inner or the outer face of the Hub flange.

Also the irregular profile of the inner face of the Hub has no effect on the extraction and insertion of the Wheel Bearing.

Removal and replacement of the Hub and Wheel Bearing takes approximately 15 Minutes per side.

Part No.	Description	Qty.
KL-0040-80	Wheel Bearing Puller	1
<i>consists of:</i>		
KL-0040-2500	Hydraulic Cylinder 17t	1
KL-0040-801	Wheel Bearing Puller Tool without drive	1

KL-0040-801 Wheel Bearing Puller without drive

As KL-0040-80, if the Hydraulic Cylinder KL-0040-2500 is already available.

Part No.	Description	Qty.
KL-0040-801	Wheel Bearing Puller without drive	1
<i>consists of:</i>		
KL-0040-2551	Adaptor M42x2 auf Ø30	1
KL-0040-2547-1	Pull spindle M20 x 550	1
KL-0040-3009	Clamping nut	1
KL-0040-800	Wheel Bearing Puller without Hydr. Cyl.	1

KL-0040-800 Wheel Bearing Puller without Hydr. Cyl.

As KL-0040-80, if the Hydraulic Cylinder KL-0040-2500, the press spindle KL-0040-2547-1 and the clamping nut KL-0040-3009 are already available.

Part No.	Description	Qty.
KL-0040-800	Wheel Bearing Puller without Hydr. Cyl.	1
<i>consists of:</i>		
KL-0040-8001	Mounting bridge	1
KL-0040-8002	Mandrel, conical	1
KL-0040-8003	Special hex. screw M12x1,25 x 45	2
KL-0040-8004	Distance bolt 50 mm, M12x1,25	2
KL-0040-8005	Mounting nut M12x1,25	2
KL-0040-8006	Adaptor 2 1/4"-14 UNS auf Ø20,5	1
KL-0040-8007	Adaptor 2 1/4"-14 UNS	1
KL-0040-8008	Distance bolt 64 mm, M12x1,25	2
KL-0040-3036	Pressure disc Nr. 17	1
KL-0040-3045	Pressure disc Nr. 23	1
KL-0040-3046	Centring disc Nr. 4	1
KL-0174-330	Puller Pöate size 3 (5-hole)	1
KL-0174-765	Puller bolt type M, M16x1,5 (l=100)	3
KL-0174-724	Puller bolt type B, M14x1,5 (l=100)	3
KL-0174-701	Hex. shoulder nut M14	3

Accessories:

KL-0040-8050 Wood Storage Tray (empty)

(For a straight storage of the wheel bearing puller set KL-0040-80)

KL-0430-1

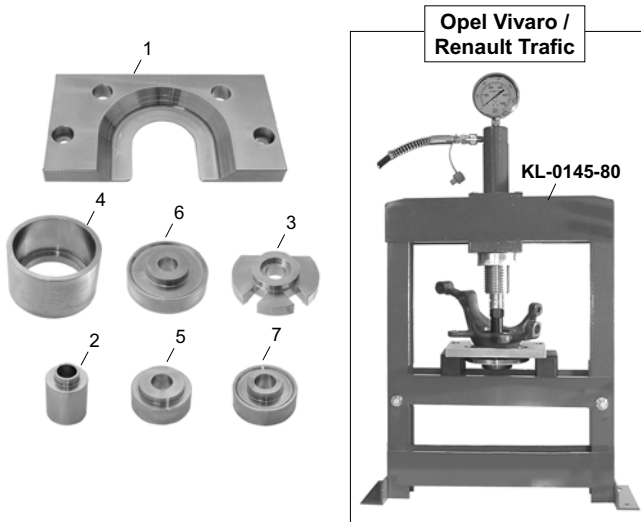

KL-0430-1 Wheel Bearing Tool Set

(German Utility Model)

Suitable for: Opel Vivaro / Renault Traffic front axle

⇒ Removal and replacement of Hub and Wheel Bearing

Because of the specific design of this vehicle it is an advantage to remove the Hub Carrier assembly from the vehicle and to remove and replace the Hub and the Bearing using the hydraulic bench press **KL-0145-80**.

It is important to note that the Wheel Bearing must be assembled with the built-in ABS sensor facing towards the inner side of the Hub Carrier assembly.

The Press Tool **KL-0430-1003** is specifically designed to prevent damage to the ABS sender-ring which is built into the inner side of the wheel bearing housing.

Advantages:

- Precise removal and replacement of the Hub and Wheel Bearing without risk of damage to the ABS sender.
- Time savings of up to 1 hour.

Specification:

Pos.	Part No.	Description	Qty.
	KL-0430-1	Wheel Bearing Tool Set	1
	<i>consists of:</i>		
1	KL-0430-1001	Base plate Hub removal	1
2	KL-0430-1002	Drift Hub removal	1
3	KL-0430-1003	Centring Disc Hub removal (support)	1
4	KL-0430-1004	Housing RA Wheel Bearing extraction/insertion FA Wheel Bearing extraction, ABS ring insertion	1
5	KL-0430-1005	Press plate FA Wheel Bearing extraction, Hub insertion	1
6	KL-0430-1006	Press plateFA Wheel Bearing insertion	1
7	KL-0430-1007	Press plate RA Wheel Bearing extraction/insertion	1

KL-0040-86

Ford Transit

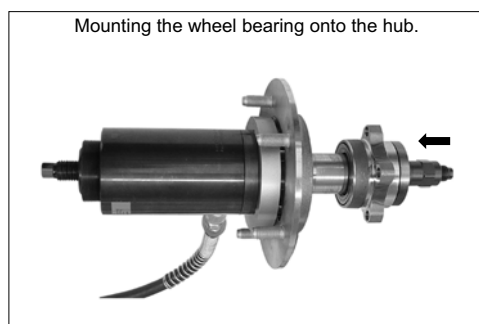
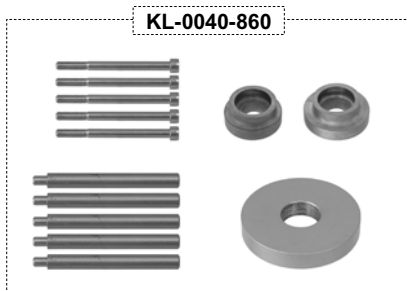

Note:

Technical data of the Hydraulic Cylinder see page 4-04 and 4-05.

KL-0040-86 Wheel Bearing Tool Set

with Hydraulic Cylinder (28 t.)

Suitable for Ford Transit 2002 onwards.

To renew the brake disc or wheel bearing, the wheel hub must be pulled out of the wheel bearing housing together with the hub and the brake disc.

The wheel bearing can be removed or installed within a few minutes, without removing the suspension strut.

KL-0040-860 Wheel Bearing Tool Set (without Hydraulic Cylinder)

As **KL-0040-86**

if hydraulic cylinder (28 t) **KL-0040-2800**, spindle **KL-0040-2812-1** and nut **KL-0040-2812-2** are already available.

Specification:

Part No.	Description	Qty.
KL-0040-850	Wheel Bearing Tool Set (without Hydraulic Cylinder)	1
<i>consists of:</i>		
KL-0040-8501	Pressure Ring	1
KL-0040-8236-4	Screw M10 x 140	5
KL-0040-8503	Mandrel	5
KL-0040-8601	Pressure disc Ø 77 mm	1
KL-0040-8602	Pressure disc Ø 68 mm	1

Note: To drive the hydraulic-cylinder KL-0040-2500 or KL-0040-2800 a hydraulic pump is necessary (see chapter 4).

KL-0049-320

VW Golf V

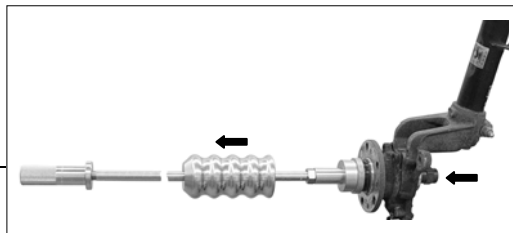
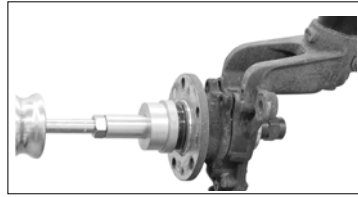
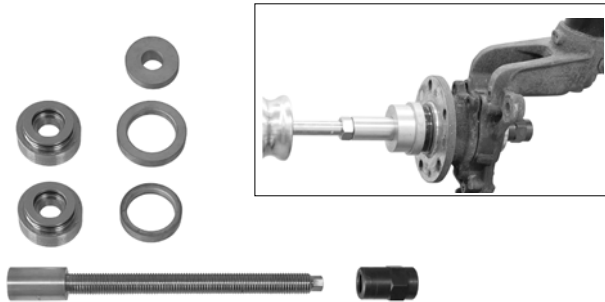

KL-0049-31



KL-0179-11



Universal



KL-0179-12



KL-0049-320 Wheel Bearing Puller

Suitable for VW Golf V.

The flange-mounted compact wheel bearing is easily and trouble-free extracted from the wishbone by using the wheel bearing puller **KL-0049-320** together with the slide hammer **KL-0049-31**.

It is not necessary to remove the wishbone.

Specification:

Part No.	Description	Qty.
KL-0049-320	Wheel Bearing Puller	1
<i>consists of:</i>		
KL-0049-3200	Pull spindle (Mounting thread M18)	1
KL-0039-1002	Location adaptor for Actuating Nut (M20 with O-Ring)	2
KL-0039-1267	Pressure Ring Ø67	1
KL-0039-1351	Centring Ring Ø51	1
KL-0039-1260	Pressure Ring Ø60	1
KL-0040-3009	Actuating Nut	1

KL-0049-31 Slide hammer

For Half-Shafts, Drive Shafts, Brake Discs and Brake drums, etc. including Adaptor 2 ¼"-14UNS to M18 suitable for the **KL-0174-Series**.

Hammer weight: 4,8 kg

Length: 690 mm

Adaptor thread: M18

KL-0179-11 Bearing Grease Arrangement

Fast, Efficient, Universal.

Simply place the bearing between the cones, tighten, and apply grease through the fitting on the end of the threaded shaft. Forces out old grease and evenly injects fresh grease.

Cone-Ø: 114 mm

Weight: 460 g

KL-0179-12 Bearing Grease Arrangement

Application as **KL-0179-11**.

Cone-Ø: 165 mm

KL-0178-10

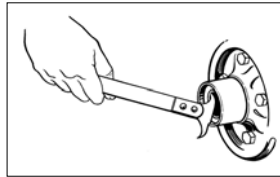

KL-0178-10 Seal Puller

For Oil and Grease Seals.

Simply insert the tip of the tool behind the oil or grease seal, press and pull. Leverage works for you. Two size tips reach in and fit nearly all seal applications.

Weight:..... 400 g

KL-0192-5 / KL-0192-6



KL-0192-5 Circlip Pliers Ø 40-100 mm

Due to the 45° angled tips, this tool is ideal for inside safety clips on gearbox repairs.

TipØ 2,5 mm

Length: 220 mm

Weight: 220 g

KL-0192-6 Circlip Pliers Ø 85-165 mm

The specially designed tips (angled at 45°) allows problem free removal and installation of inner safety clips on **wheel bearing repairs**.

TipØ 3 mm

Length: 310 mm

Weight: 410 g

KL-0179-51 K

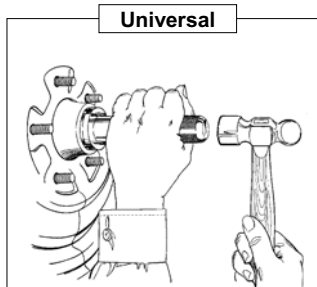

KL-0179-51 K Bearing Race and Seal Assembly Tool Set Ø 40-81 mm

Makes it easier to insert bearing race and seals without damage to race and axle housing. This master set includes nine disc sizes to fit most standard wheel bearings. Turn discs over to drive seals. Packages in convenient clam shell for storage.

The set contains a Drift and 9 Pressure Discs [Ø 40 mm; Ø 44 mm; Ø 50 mm; Ø 59 mm; Ø 63 mm; Ø 65 mm; Ø 72 mm; Ø 76 mm; Ø 81 mm].

The Tool is delivered in a plastic case.

Weight:..... 1360 g

KL-0040-91



KL-0040-91 Bearing Race Assembly Tool Set

The bearing tool simplifies the assembly of the outer bearing race of taper-roller bearings. The set contains Drift **KL-0040-3090** and 10 Pressure Discs with Ø of 40/25mm, 40/32mm, 42mm, 42/32,5mm, 47/37,5mm, 49,5mm, 49,5/48mm, 50/41,5mm, 52/41mm, 53,5mm.

The Drift **KL-0040-3090** also fits Wheel Bearing Tool Kits **KL-0040-3** to **KL-0040-5**.

Wheel Hub Bearing unit extraction with the new Puller KL-0041-38.

Wheel Hub Bearing unit

German Utility Model



locking crown

The problem with the Extraction:

A very high pulling force is necessary to extract a wheel hub bearing unit with locking crown. The resistance of the safety locking crown has to be overcome both in case of rust and corrosion and during bearing extraction. This means that during the extraction the locking teeth of the locking crown break.

Wheel bearing pullers provided with a mechanic spindle are not suitable to perform this operation due to high pulling force.

3

Extract wheel hub bearing unit with the wheel hub puller tool KL-0041-38



▼ **Universal suitable for hubs-Ø till 250 mm**

▼ **Adjusting spindle preattunement allows a problemless installation.**

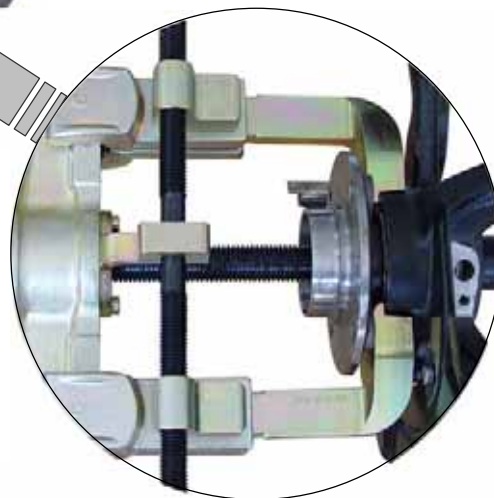

▼ **Universal**

▼ **Specific**

▼ **Easy**

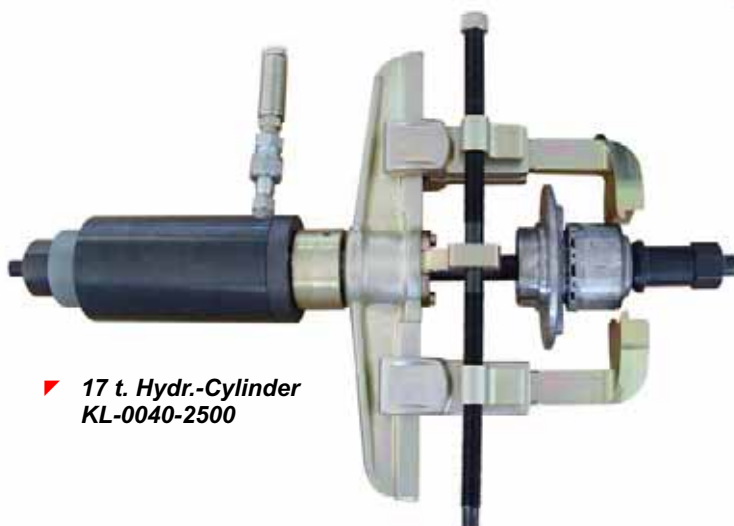

▼ **17 t. Hydr.-Cylinder KL-0040-2500**

▼ **The two support surfaces and spacer plates offer universal supporting possibilities.**

▼ **Easy handling and easy to operate.**

Further information see page 3.3-01.

Wheel Hub Bearing unit *insertion* with the new tool set KL-0041-....

German Utility Model

The problem with the Insertion:

A particular feature of the wheel hub bearing unit is that the external safety ring that before had a safety function, has been replaced by a locking crown fixed on the wheel bearing of the wheel hub bearing unit. The wheel hub and the wheel bearing are no more separated but a complete unit.

This means that the wheel bearing can no more as in the past be settled with a pressure piece under a press or with a standard wheel bearing tool. As it is well known, when pressing a bearing into a bearing housing, only the external bearing ring can be pressed. The non-observance will destroy the bearing. Only an appropriate special tool can press the wheel hub only in order to press the bearing into the bearing housing. But this procedure will damage the new bearing on the wheel hub. To avoid this kind of damage we have designed a special tool that is placed behind the wheel hub to the bearing external ring, on the locking crown. Consequently the wheel bearing is pressed into the external bearing ring and the locking crown locks in place regularly. By using the hydraulic cylinder **KL-0040-2500** the insertion of new wheel hub bearing units is performed.

Wheel Hub Bearing unit



3

Insert wheel hub bearing unit with the wheel bearing too KL-0041-4.. Series

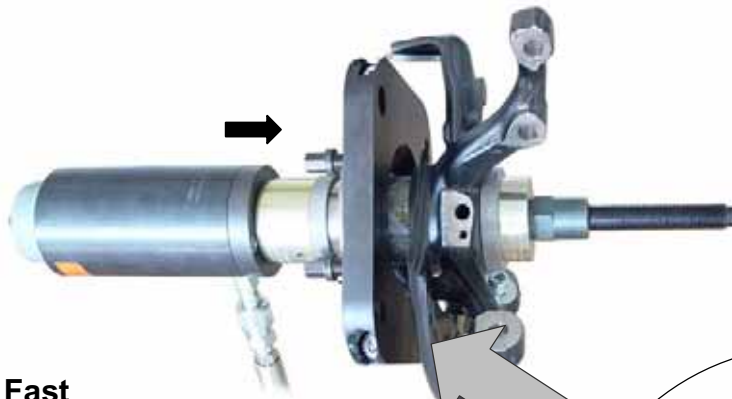

Fast

Safe

Problemless

17 t. Hydr.-Cylinder
KL-0040-2500



KL-0041-42

Bearing-Ø
62 mm

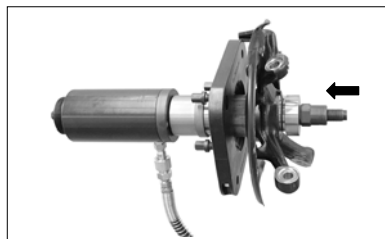
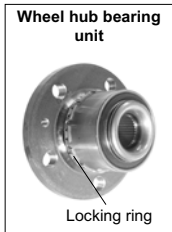
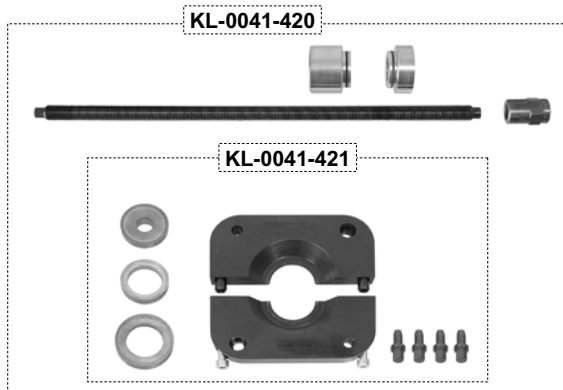

KL-0041-43

Bearing-Ø
66 mm

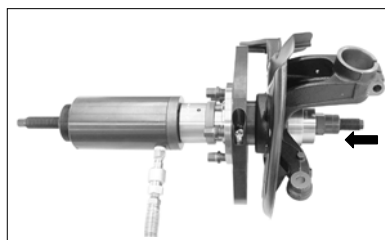
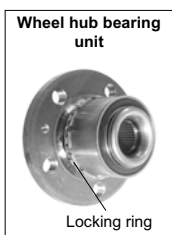
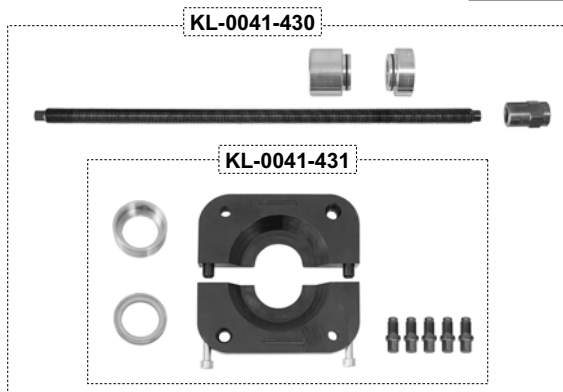

KL-0041-42 Wheel Bearing Puller Tool Set with Hydraulic Cylinder (German Utility Model)

Suitable for vehicles with bearing-Ø 62 mm e.g. VW Lupo etc.

For a fast and safe insertion of the wheel hub bearing unit.

KL-0041-420 Wheel Bearing Tool Set without Hydraulic Cylinder

As KL-0041-42 if Hydraulic Cylinder KL-0040-2500 is already available.

Specification (KL-0041-420):

Part No.	Description	Qty.
KL-0039-1002	Clamping nut (M20) retaining adaptor with O-ring	1
KL-0039-1003	Hydraulic Cylinder retaining adaptor with O-ring	1
KL-0040-2547-1	Pull spindle M20 x 550	1
KL-0040-3009	Clamping nut	1
KL-0041-421	Supplement kit Lupo Ø62	1

Part No.	Description	Qty.
KL-0041-421	Supplement kit Lupo Ø62	1
<i>consists of:</i>		
KL-0041-4200	Clamping jaw pair Ø62	1
KL-0041-3921	Pressure screw M12x1.5	4
KL-0039-1265	Pressure ring Ø65	1
KL-0039-1359	Centring ring Ø59	1
KL-0039-1273	Pressure ring Ø73	1

Note: The wheel hub puller KL-0041-38 will be required to extract the wheel hub/bearing unit. (see page 3.3-01)

KL-0041-43 Wheel Bearing Puller Tool Set with Hydraulic Cylinder (German Utility Model)

Suitable for vehicles with bearing-Ø 66 mm e.g. VW Polo'02 onwards, Seat Fabia '00 onwards etc.

For a fast and safe insertion of the wheel hub bearing unit.

KL-0041-430 Wheel Bearing Tool Set without Hydraulic Cylinder

As KL-0041-43 if Hydraulic Cylinder KL-0040-2500 is already available.

Specification (KL-0041-430):

Part No.	Description	Qty.
KL-0039-1002	Clamping nut (M20) retaining adaptor with O-ring	1
KL-0039-1003	Hydraulic Cylinder retaining adaptor with O-ring	1
KL-0040-2547-1	Press spindle M20 x 550	1
KL-0040-3009	Clamping nut	1
KL-0041-431	Supplement kit Ø66 mm	1

Part No.	Description	Qty.
KL-0041-431	Supplement kit Ø66 mm	1
<i>consists of:</i>		
KL-0041-4300	Clamping jaw pair Ø66	1
KL-0041-3931	Pressure screw M14x1.5	5
KL-0039-1265	Pressure ring Ø65	1
KL-0039-1668	Press/support tube short Ø68	1

Note: The wheel hub puller KL-0041-38 will be required to extract the wheel hub/bearing unit. (see page 3.3-01)

An hydraulic pump (see Chapter 4) will be required to drive the KL-0040-2500.

KL-0041-44



Bearing-Ø
72 mm

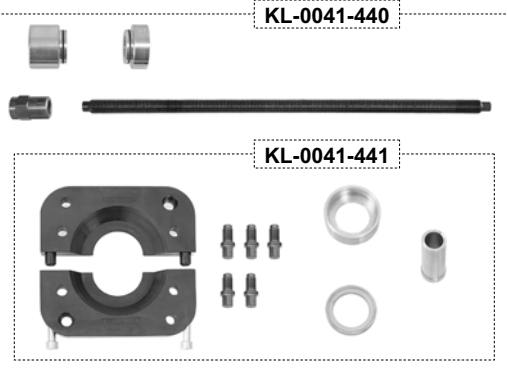

KL-0041-440

KL-0041-441

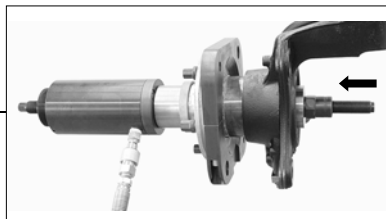

KL-0041-45



Bearing-Ø
85 mm

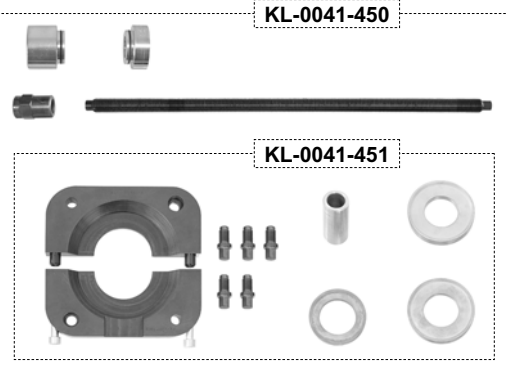

KL-0041-450

KL-0041-451

KL-0041-41

VW Touareg /
Porsche Cayenne



KL-0041-410

KL-0041-411

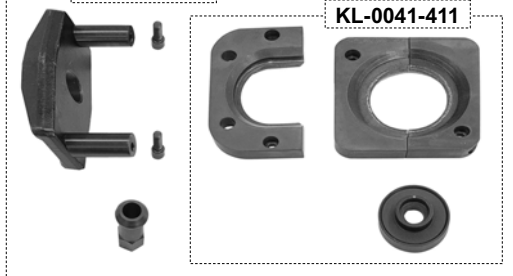

Wheel hub bearing
unit

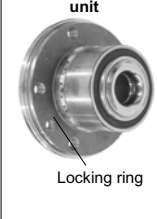

Locking ring

Wheel hub bearing unit extraction

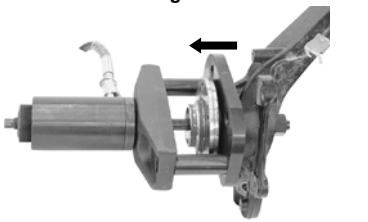

KL-0041-44 Wheel Bearing Puller Tool Set with Hydraulic Cylinder

Suitable for vehicles with bearing-Ø 72 mm e.g. Audi A2 '00 onwards, Seat Ibiza'02 onwards, Škoda Fabia '00 onwards and VW Polo '02 onwards etc.

For a fast and safe insertion of the wheel hub bearing unit.

KL-0041-440 Wheel Bearing Puller Tool Set (without Hydraulic Cylinder)

As KL-0041-44 if Hydraulic Cyl. KL-0040-2500 is already available.

Specification (KL-0041-440):

German Utility Model

Part No.	Description	Qty.
KL-0039-1002	Clamping nut (M20) retaining adaptor with O-ring	1
KL-0039-1003	Hydraulic Cylinder retaining adaptor with O-ring	1
KL-0040-2547-1	Pull spindle M20 x 550	1
KL-0040-3009	Clamping nut	1
KL-0041-441	Supplement kit Ø72mm	1
Part No.	Description	Qty.
KL-0041-441	Supplement kit Ø72mm	1
<i>consists of:</i>		
KL-0041-4400	Clamping jaw pair Ø72	1
KL-0041-3931	Pressure screw M14x1.5	5
KL-0039-1802	Centring tube long Ø27.5	1
KL-0039-1265	Pressure ring Ø65	1
KL-0039-1674	Press/support tube short Ø74	1

Note: The wheel hub puller KL-0041-38 will be required to extract the wheel hub/bearing unit. (see page 3.3-01)

KL-0041-45 Wheel Bearing Puller Tool Set with Hydraulic Cylinder

Suitable for vehicles with bearing-Ø 85 mm; e.g. VW T5 front axle and rear axle etc.

For a fast and safe insertion of the wheel hub bearing unit.

KL-0041-450 Wheel Bearing Puller Tool Set (without Hydraulic Cylinder)

As KL-0041-45 if Hydraulic Cyl. KL-0040-2500 is already available.

Specification (KL-0041-450):

German Utility Model

Part No.	Description	Qty.
KL-0039-1002	Clamping nut (M20) retaining adaptor with O-ring	1
KL-0039-1003	Hydraulic Cylinder retaining adaptor with O-ring	1
KL-0040-2547-1	Pull spindle M20 x 550	1
KL-0040-3009	Clamping nut	1
KL-0041-451	Supplement kit Ø85mm	1
Part No.	Description	Qty.
KL-0041-451	Supplement kit Ø85mm	1
<i>consists of:</i>		
KL-0041-4500	Clamping jaw pair Ø85	1
KL-0041-3931	Pressure screw M14x1.5	5
KL-0039-1502	Pressure ring Ø93	1
KL-0039-1803	Centring tube long Ø93	1
KL-0039-1273	Pressure ring Ø73	1
KL-0039-1289	Pressure ring Ø89mm	1

Note: The wheel hub puller KL-0041-38 will be required to extract the wheel hub/bearing unit. (see page 3.3-01)

KL-0041-41 Wheel Bearing Puller Tool Set

Suitable for VW Touareg and Porsche Cayenne.

For a fast and safe insertion of the wheel hub bearing unit.

KL-0041-410 Wheel Bearing Puller Tool Set (without Hydraulic Cylinder)

As KL-0041-41 if Hydraulic Cylinder KL-0040-2500, the press spindle KL-0040-2512 and the clamping nut KL-0040-3009 are already available.

Specification (KL-0041-410)

Part No.	Description	Qty.
KL-0330-0002	Distance piece	2
KL-0330-0003	Screw M12 x 30	4
KL-0330-0004	Bearing bridge	1
KL-0330-0009	Hex shoulder nut	1
KL-0041-411	Supplement kit Touareg / Cayenne	1
Part No.	Description	Qty.
KL-0041-411	Supplement kit Touareg / Cayenne	1
<i>consists of:</i>		
KL-0041-4110	Base plate VW Touareg / Porsche Cayenne.	1
KL-0041-4100	Clamping jaw pair	1
KL-0041-4113	Pressure disc	1

KL-0041-38

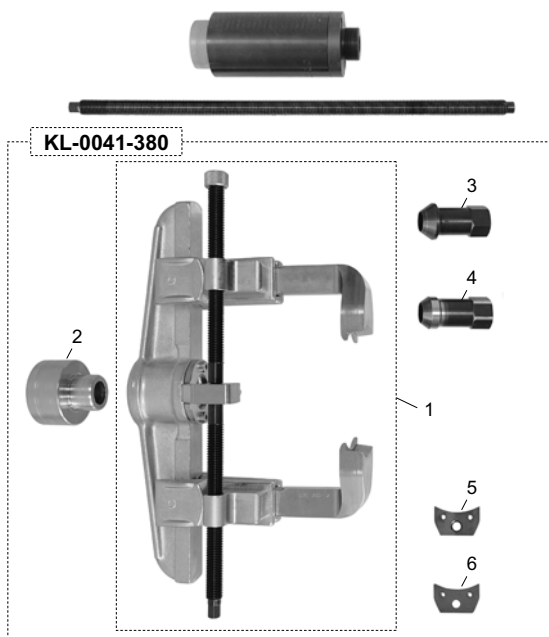

KL-0041-380

2

3

4

5

6

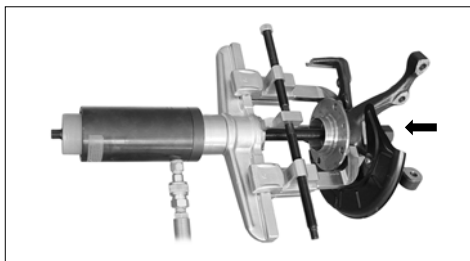

KL-0041-38 Wheel Hub Puller with adjusting spindle, with hydr. Cyl. (German Utility Model)

The wheel hub bearing unit or the wheel hub can be quickly, safely and precisely pulled out by using the wheel hub puller **KL-0041-38**. Thanks to the hydraulic cylinder **KL-0040-2500** even stuck, stubborn or rusty wheel hub bearing units or wheel hubs are no more a problem. Thanks to this wheel hub puller special design a variety of wheel hubs up to 250 mm diam. can be removed.

KL-0041-380 Wheel Hub Puller with adjusting spindle, without Hydraulic Cylinder

As **KL-0041-38**, if the Hydraulic Cylinder **KL-0040-2500** and the press spindle **M20 x 550 KL-0040-2547-1** are already available.

Specification:

Pos.	Part No.	Description	Qty.
	KL-0041-380	Wheel Hub Puller with Shift Spindle, without Hydraulic Cylinder	1
<i>consists of</i>			
1	KL-0041-3800	Wheel hub puller base tool with adj. spindle	1
2	KL-0041-3802	Adaptor M42x2	1
3	KL-0041-3811	Clamping nut Ø38	1
4	KL-0041-3812	Clamping nut Ø30	1
5	KL-0041-3821	Distance plate with magnet 4 mm	1
6	KL-0041-3822	Distance plate with magnet 6 mm	1

Note: The plates **KL-0041-3821** and **KL-0041-3822** are used as distance and compensating plates if during the wheel hub removal you can support on the hook underside and the supporting surface is unequal.

KL-0041-36

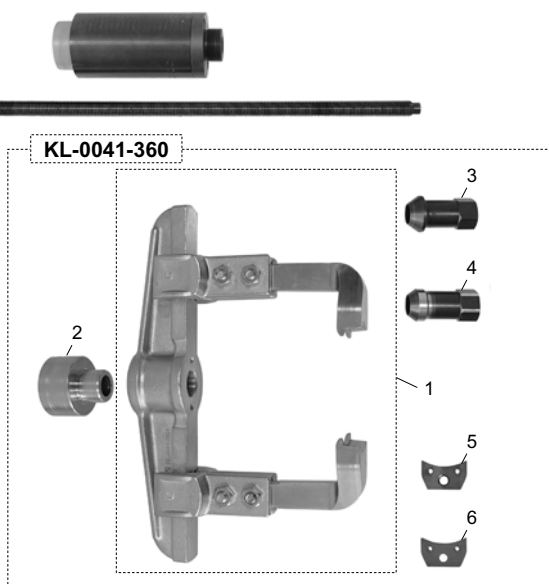

KL-0041-360

2

3

4

5

6



KL-0041-36 Wheel Hub Puller without adjusting spindle, with hydr. Cyl. (German Utility Model)

The wheel hub bearing unit or the wheel hub can be quickly, safely and precisely pulled out by using the wheel hub puller **KL-0041-36**. Thanks to the hydraulic cylinder **KL-0040-2500** even stuck, stubborn or rusty wheel hub bearing units or wheel hubs are no more a problem. Thanks to this wheel hub puller special design a variety of wheel hubs up to 250 mm diam. can be removed.

KL-0041-360 Wheel Hub Puller without adjusting spindle, without Hydraulic Cylinder

As **KL-0041-36**, if Hydraulic Cylinder **KL-0040-2500** and the press spindle **M20 x 550 KL-0040-2547-1** are already available.

Specification:

Pos.	Part No.	Description	Qty.
	KL-0041-360	Wheel Hub Puller without adjusting spindle, without Hydraulic Cylinder	1
<i>consists of</i>			
1	KL-0041-3600	Wheel hub puller base tool without adjusting spindle	1
2	KL-0041-3802	Adaptor M42x2	1
3	KL-0041-3811	Clamping nut Ø38	1
4	KL-0041-3812	Clamping nut Ø30	1
5	KL-0041-3821	Distance plate with magnet 4 mm	1
6	KL-0041-3822	Distance plate with magnet 6 mm	1
Accessories: (not ill.)			
	KL-0041-361	Shift unit	1

➡ The new KLANN Wheel Bearing/Bush Tool KL-0039-Series !!!!! ⬅

The big advantages of the new and unique bearing/bush tools are:

- Modular system provided with a versatile hydraulic drive (KL-0040-2500), two adaptors and universally combinable centring and pressure rings as well as pressure and support sleeves.
- Universal field of application.
- Huge time and cost savings due to the easy assembling of the required tool.

Application example: *Wheel Bearing insertion.*

(Wheel bearing extraction see page 3.1-01)

1. Configuration of the required pieces and tool assembling:

Measure inner-/outer-Ø, identify centring and pressure ring (wheel bearing), identify pressure ring (wheel bearing housing support) (see table page 3.1-03)

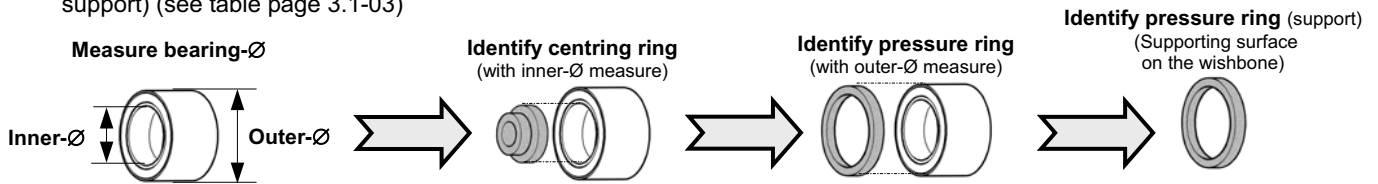

2. Mount the tool on the wishbone and press the wheel bearing in.

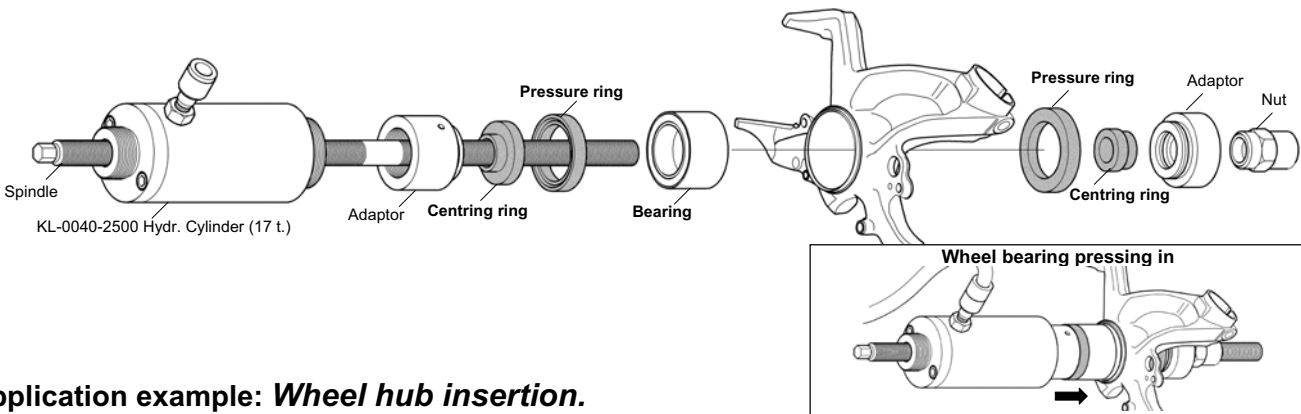

Application example: *Wheel hub insertion.*

1. Configuration of the required pieces and tool assembling:

Measure wheel hub shoulder-Ø, identify pressure and centring ring; measure inner bearing race-Ø identify pressure ring (wheel bearing support) (see table page 3.1-03)

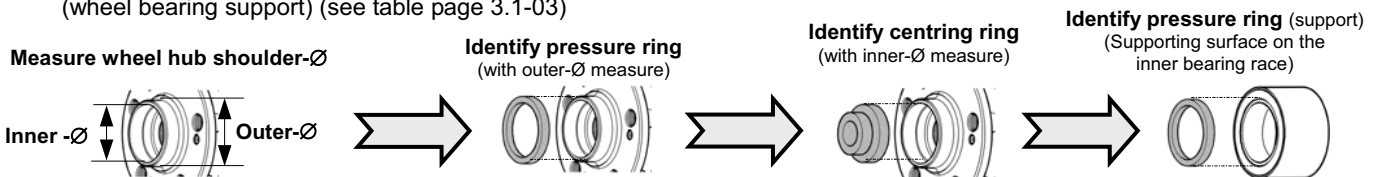

2. Mount the tool on the wishbone and press the wheel hub in.

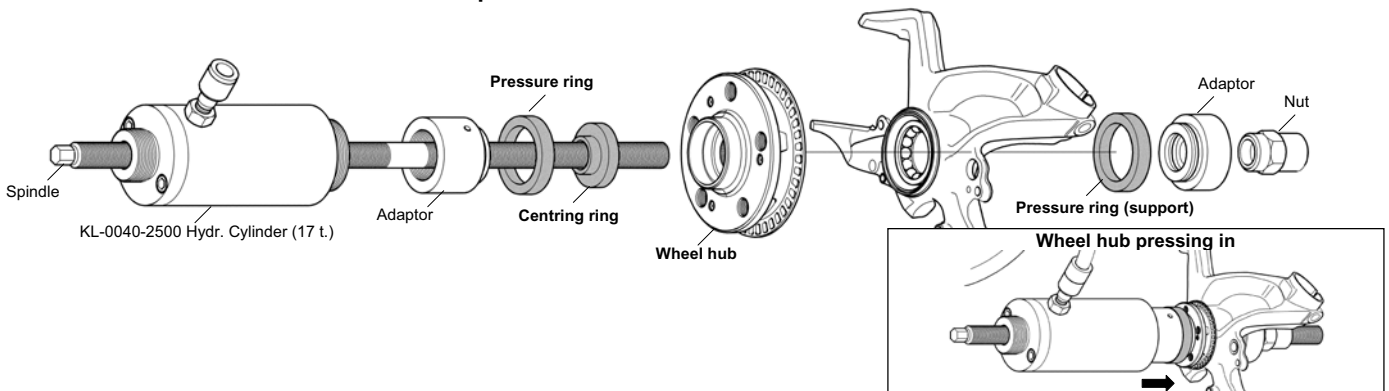

Note: The hydraulic cylinder KL-0040-2500 shall be operated by a hydraulic pump. See page 4-08.

KL-0105 / KL-0106 / KL-0107



The Pressure Bolts are not suitable for all vehicles

KL-0105 Pressure Bolts M12x1.25

For Wheel Hub extraction on **Alfa Romeo, Citroën, Fiat, Lancia, Lada, Peugeot, Seat.**

KL-0106 Pressure Bolts M12x1.5

For Wheel Hub extraction on **BMW, Ford, Mazda, Mercedes, Opel/Vauxhall, Renault, Seat, VW.**

KL-0107 Pressure Bolts M14x1.5

For Wheel Hub extraction on **Audi, Citroën, Fiat, Mercedes, Peugeot, VW.**

KL-0041-3

VW-Audi, Opel, Renault, Peugeot, etc.

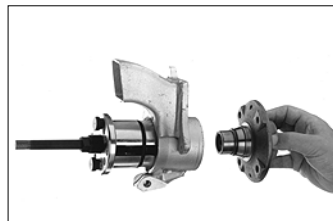

KL-0041-3 Press Tool

This press tool in improved and strengthened form is designed for quick and easy removal of wheel hubs.

This tool is positioned into the hub with the lips in line with the circlip groove and is infinitely adjustable by the index disc to bearing diameter.

Application: **VW-Audi, Opel/Vauxhall, Renault, Peugeot, Citroën** up to the bearing diameter 82 mm.

KL-0330-12

Mercedes

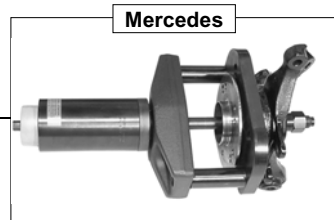

KL-0330-12 Wheel Hub Puller hydr. (17 t)

For **Mercedes W124, W129, W140, W163, W168, W169, W201, W202, W203, W210, W211, W245** etc.

This tool allows stubborn wheel hubs to be withdrawn without damage to the hub or bearing housing. Removal of the wheel hubs is performed on the vehicle within a few minutes.

Note: For the **Mercedes W124 (estate)**, baseplate **KL-0330-0001** is also needed.

KL-0330-121



KL-0330-1201 - Base Plate

If wheel hub puller **KL-0330** with baseplate **KL-0330-0001** is available, baseplate **KL-0330-1201** is needed for the new vehicle models.

KL-0330-121 Wheel Hub Puller

As **KL-0330-12** but without Hydraulic Cylinder **KL-0040-2500** and without Spindle **KL-0040-2512**.

Examples of application:

Press out the drive-shaft with the mechanical spindle.

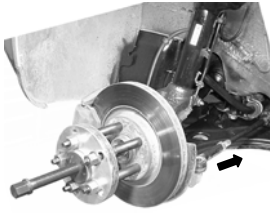

Press out the drive-shaft flange



Press out the drive-shaft using 17 ton Hydraulic Cylinder.



Remove the hub using a slide-hammer

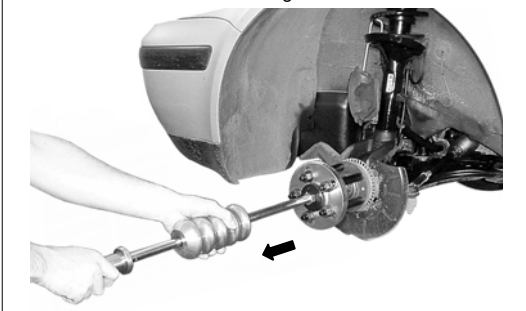

Wheel Hubs

Standard Hub,
4 Wheel Bolts



Standard Hub,
5 Wheel nuts



4X4 Off-Road,
6 Wheel nuts



Important Data

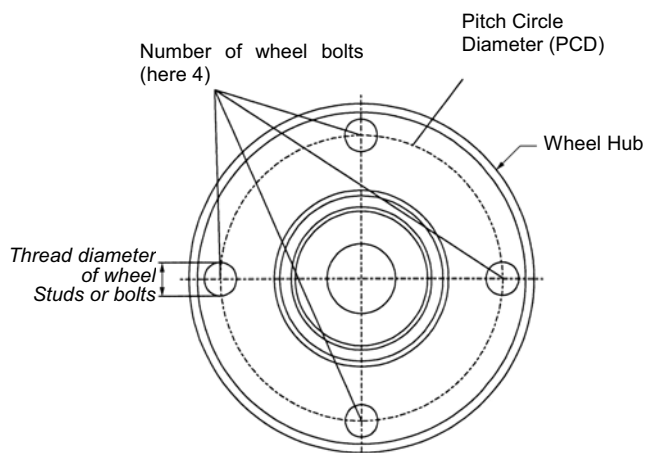

KL-0174 Puller Series

The **KL-0174 Puller Series** used together with the hydraulic cylinder **KL-0215-10** (17t.) or with the hydraulic spindle **KL-0045-7** (12t.) allow to *press out drive shafts* glued with loctite or rusted. Together with the slide hammer **KL-0049-31** *wheel hubs, brake drums and half shafts can be removed directly in the vehicle.*

Thanks to the use and combination of different perforated disks, tie bolts and drives the Puller Series KL-0174 is almost universally applicable.

Application:

- Drive shaft pressing out:**

⇒ mechanic or hydraulic

(depending on the drive variant see page 3.3-06)

e.g. the use of the 17 t. hydraulic cylinder **KL-0215-10** (consisting of the hydraulic cylinder **KL-0040-2500** and of the press spindle **KL-0040-2510**) allow to press out even rusted, very stuck or glued drive shafts.

- Wheel hubs, half shafts and brake drums removal:**

⇒ with slide hammer **KL-0049-31**

(see page 3.3-06)

By using the slide hammer **KL-0049-31** *wheel hubs, brake drums and half shafts can be removed directly in the vehicle.*

In order to select the correct puller, the following important data must be known:

- PCD and number of studs (3, 4, 5 or 6).
→ important to establish the correct plate size with the correct hole pattern
- Wheel Studs (type M) or Screws (type B) and thread diameters.
→ important to select the puller bolts with inner or outer threads.
- What drive method is to be used, mechanical spindle, slide-hammer, Hydraulic spindle or Hydraulic Cylinder?
→ important to establish the length of puller bolts required (see table).

1. Assemble the puller:

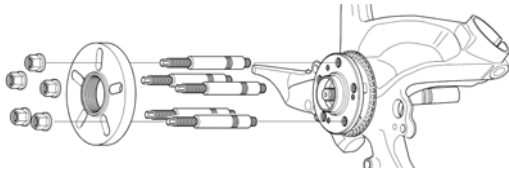

2. Press out drive shaft:

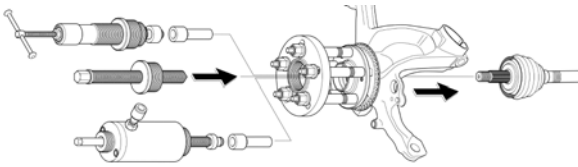

3. Extract wheel hub:

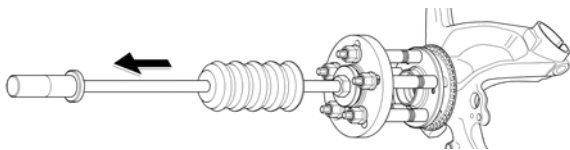

Puller Plates

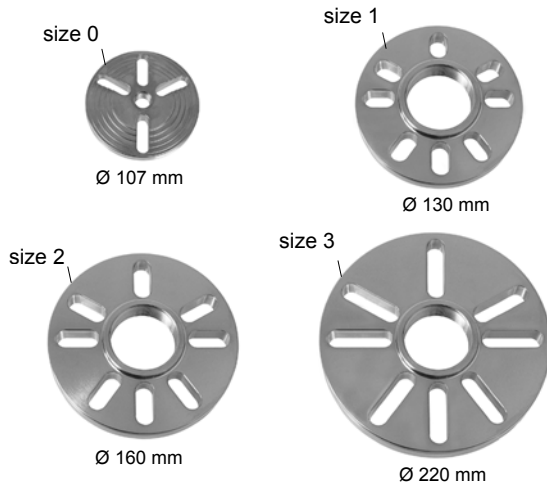

Adaptors



Press spindles

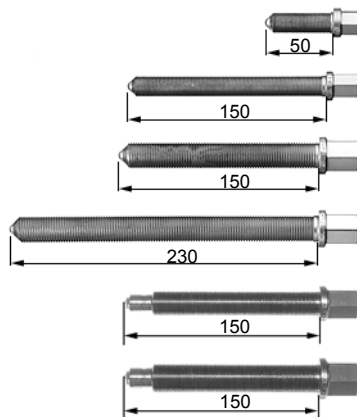

Press pieces



Spare Parts for the assembly of a Puller from the Puller-Series KL-0174-...

The puller plates with the sizes 0, 1, 2 and 3 can be assembled to an all-purpose puller-system by using different adaptors, spindles, puller bolts, screws and drives.

Puller plates:

Part No.	Description	Inner Thread	PCD [mm]	Outer-Ø [mm]	Hole Pattern
KL-0174-020	Puller plate size 0	M16x1,5	40 - 88	108	2+3-hole
KL-0174-140	Puller plate size 1	M42x2	76 - 105	130	3-4-a.5- hole
KL-0174-240	Puller plate size 2	2 1/4" - 14 UNS	90 - 130	160	3-4-a.5- hole
KL-0174-360	Puller plate size 3	2 1/4" - 14 UNS	100 - 180	220	3-4 a. 5- hole

Thread Adaptors: (other dimensions available upon request)

Part No.	Description
KL-0174-510	Adaptor M42x2 x M14 (*KL-0049-2003)
KL-0174-511	Adaptor M42x2 x M14x1,5
KL-0174-513	Adaptor M42x2 x M16x1,5
KL-0174-515	Adaptor M42x2 x M18x1,5
KL-0174-516	Adaptor M42x2 x M18 (*KL-0049-3005)
KL-0174-517	Adaptor M42x2 x M20x2
KL-0174-519	Adaptor M42x2 x M22x2 (*KL-0049-2007)
KL-0174-521	Adaptor M42x2 x M24x2
KL-0174-535	Adaptor 1 1/2"-16UN x M18 (for KL-0049-31 to SP)
KL-0174-540	Adaptor 2 1/4"-214UNS x M14
KL-0174-542	Adaptor 2 1/4"-14UNS x M16x1,5
KL-0174-544	Adaptor 2 1/4"-14UNS x M18x1,5
KL-0174-545	Adaptor 2 1/4"-14UNS x M18
KL-0174-547	Adaptor 2 1/4"-14UNS x M20x2
KL-0174-549	Adaptor 2 1/4"-14UNS x M22x2
KL-0174-551	Adaptor 2 1/4"-14UNS x M24x2
KL-0174-552	Adaptor 2 1/4"-14UNS x M42x2 (for KL-0045-7)
KL-0174-555	Adaptor 2 1/4"-14UNS x 1 1/2"-16UN Ø approx. 36,5 mm (for SP-Hydr.-Sp.)
KL-0174-559	Adaptor 2 1/4"-14UNS x 2 1/4"-14UNS Ø approx. 55,5 mm (see page 3.3-06)

*Old part no.

Press Spindles:

Part No.	Description
KL-0174-610	Spindle M14x1,5 x 150
KL-0174-611	Spindle M16x1,5 x 50
KL-0174-615	Spindle M18x1,5 x 150
KL-0174-618	Spindle M20x1,5 x 230
KL-0174-619	Spindle M20x2 x 150
KL-0174-623	Spindle M22x2 x 150
KL-0174-624	Spindle M22x2 x 230
KL-0174-620	Spindle with pivot (Ø 14 mm) M20x2 x 230
KL-0174-812	Spindle with pivot (Ø 14 mm) M16x1,5 x 150
KL-0174-817	Spindle with pivot (Ø 14 mm) M20x1,5 x 150

Pressure pieces:

e.g. to press out wheel hubs. Suitable for the spindles KL-0174-812 and KL-0174-817.

Part no.	Description	
KL-0174-851	Pressure piece for hub	Ø 34 mm
KL-0174-854	Pressure piece for hub	Ø 48 mm

Puller Bolts Type „B“

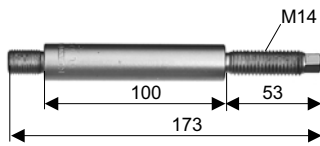

Standard wheel hub (wheel bolt system)



Puller Bolts Type „M“

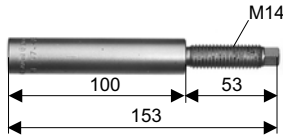

Standard wheel hub, (wheel nut system)



Shoulder nuts



Drives:

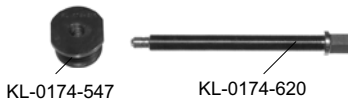

KL-0045-7 Hydraulic-Spindle (by using with the KL-0174-Series, use adaptor KL-0174-552!)



Technical Data see page 4-04

KL-0215-10

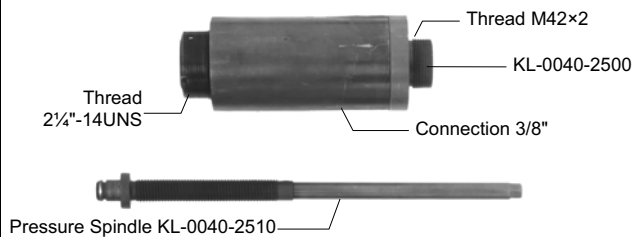

Technical Data see page 4-04

Note

A Hydraulic Pump (see page 4-08) will be required to drive the KL-0040-2500.

KL-0040-2561



Drive-Shaft extraction with the Hydraulic Cylinder (17 t.)

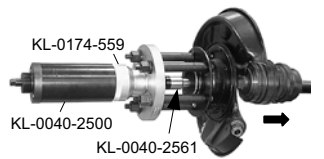

KL-0174-559



KL-0049-31 with adaptor 2 1/4" UNS to M18



Puller Bolts:

Puller Bolts Type „B“ - Outer thread (Wheel bolt system)

Part No.	Description
KL-0174-722	Puller bolts type B M12x1,25 Distance area = 100 mm
KL-0174-723	Puller bolts type B M12x1,5 Distance area = 100 mm
KL-0174-724	Puller bolts type B M14x1,5 Distance area = 100 mm
KL-0174-725	Puller bolts type B M16x1,5 Distance area = 100 mm
KL-0174-726	Puller bolts type B M12x1,75 Distance area = 100 mm

Puller Bolts Type „M“ - Inner thread (Wheel nut system)

Part No.	Description
KL-0174-762	Puller bolts type M M12x1,25 Distance area = 100 mm
KL-0174-763	Puller bolts type M M12x1,5 Distance area = 100 mm
KL-0174-764	Puller bolts type M M14x1,5 Distance area = 100 mm
KL-0174-765	Puller bolts type M, M16x1,5 Distance area = 100 mm
KL-0174-767	Puller bolts type M, M14 Distance area = 100 mm

Shoulder nuts

Part No.	Description
KL-0174-700	Shoulder nut set (6 pieces.) M14 - hex 22
KL-0174-701	Shoulder nut M14 - hex 22

Drives:

Mechanical:

(consists of adaptor und press spindle see page 3.3-05)

Example:

Part No.	Description	Qty.
KL-0174-547	Adaptor 2 1/4"-14UNS on M20x2	1
KL-0174-620	Spindle M20x2 x 230	1

KL-0045-7 Hydraulic-Spindle 12t

The KL-0045-7 is a hydraulic spindle with a 120 kN (12 t) capacity designed to fit a range of KLANN tool systems.

The tool consists of a top quality steel body, twin internal pistons, replaceable O-rings and various sealing closures.

For further hydraulic accessoires see chapter 4.

KL-0215-10 Hydraulic-Cylinder with Pressure Spindle

Used in conjunction with an endless assortment of Press and Propping adaptors, and due to its special construction, this tool offers a quick, easy, clean and safe solution to the problem of extracting and replacing metallastic bushes, ball-joints, wheel-bearings, Hubs, drive-shafts, etc.

The Hydraulic Cylinder KL-0215-10 (17t) is also ideal for use with KL-0040-3, KL-0174-Series, KL-0330. Hydraulic coupling and threaded adaptor is not included in the delivery.

For further Hydraulic Accessories see Chapter 4.

KL-0040-2561 Pressure Piece

For use with the pressure spindle KL-0040-2510 in conjunction with Hydraulic Cylinder KL-0040-2500 to press out loctited drive shafts.

KL-0174-559 Adaptor 2 1/4"-14UNS to 2 1/4"-14UNS

Required for the use of Hydraulic Cylinders KL-0215-10 and KL-0040-25 in conjunction with Puller Discs size 1 and 2 with PCD Ø of 90 - 102 mm.

KL-0049-31 Slide Hammer

For Half-Shafts, Drive Shafts, Brake Discs and Brake drums, etc. including Adaptor 2 1/4"-14UNS to M18 suitable for the KL-0174-Series.

Hammer weight: 4,8 kg

Length: 690 mm

KL-0174-110

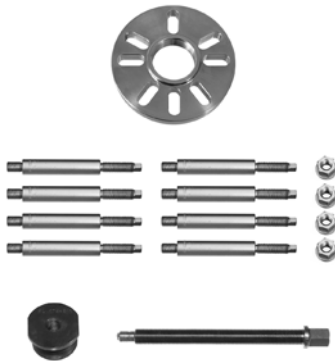

KL-0174-110 Puller Set

Suitable for: **VW-Audi, Alfa Romeo, BMW, Citroën, Fiat Ford, Mazda, Mercedes, Opel, Peugeot, Porsche, Renault, Seat, Škoda, etc.**

Part No.	Description	Qty.
KL-0174-110	Puller Set	1
<i>consists of:</i>		
KL-0174-240	Puller plate size 2 (3-4-a.5-hole)	1
KL-0174-723	Puller bolts type B, M12x1,5 (l=100)	4
KL-0174-724	Puller bolts type B, M14x1,5 (l=100)	4
KL-0174-701	Hex. shoulder nut M14	4
KL-0174-547	Adaptor 2¼"-14UNS on M20x2	1
KL-0174-620	Spindle M20x2 x 230	1

KL-0174-111

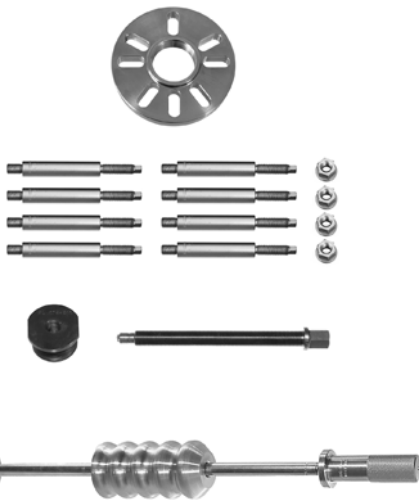

KL-0174-111 Puller Set with slide hammer

Suitable for: **VW-Audi, Alfa Romeo, BMW, Citroën, Fiat Ford, Mazda, Mercedes, Opel, Peugeot, Porsche, Renault, Seat, Škoda, etc.**

Part No.	Description	Qty.
KL-0174-111	Puller set	1
<i>consists of:</i>		
KL-0174-240	Puller plate size 2 (3-4-a.5-hole)	1
KL-0174-723	Puller bolts type B, M12x1,5 (l=100)	4
KL-0174-724	Puller bolts type B, M14x1,5 (l=100)	4
KL-0174-701	Hex. Shoulder nut M14	4
KL-0174-547	Adaptor 2¼"-14UNS on M20x2	1
KL-0174-620	Spindle M20x2 x 230	1
KL-0049-31	Slide hammer 4,8 kg	1

Note: The Puller Sets **KL-0174-110** and **KL-0174-111** may be further enhanced by the addition of further Puller Discs, Adaptors, Spindles and Puller Bolts.

KL-0174-107 KA

Universal



KL-0174-107 KA Universal Puller Set

Suitable e.g. for **VW-Audi, Alfa Romeo, BMW, Citroën, Fiat Ford, Honda, Hyundai, Lancia, Mazda, Mercedes, Mitsubishi, Nissan, Opel, Renault, Rover, Subaru, Suzuki, Seat, Škoda, Toyota, etc.**

By using the Puller Set **KL-0174-107 KA** *wheel hubs, brake drums and half shafts can be removed directly in the vehicle and rusted or glued with loctite drive shafts are pressed out.*

Part No.	Description	Qty.
KL-0174-107 KA	Universal Puller Set	1
<i>consists of:</i>		
KL-0174-240	Puller plate size 2 (3-4-a.5-hole)	1
KL-0174-350	Puller plate size 3 (4-a.5-hole)	1
KL-0174-722	Puller bolts type B, M12x1,25 (l=100)	4
KL-0174-723	Puller bolts type B, M12x1,5 (l=100)	4
KL-0174-724	Puller bolts type B, M14x1,5 (l=100)	4
KL-0174-725	Puller bolts type B, M16x1,5 (l=100)	4
KL-0174-726	Puller bolts type B, M12x1,75 (l=100)	4
KL-0174-762	Puller bolts type M, M12x1,25 (l=100)	4
KL-0174-763	Puller bolts type M, M12x1,5 (l=100)	4
KL-0174-764	Puller bolts type M, M14x1,5 (l=100)	4
KL-0174-765	Puller bolts type M, M16x1,5 (l=100)	4
KL-0174-701	Hex. Shoulder nut M14	4
KL-0174-559	Adaptor 2¼"-14UNS on 2¼"-14UNS	1
KL-0049-31	Slide hammer 4,8 kg	1
KL-0040-2500	Hydraulic-Cylinder 17t	1
KL-0040-2510	Pressure spindle	1
KL-0040-2561	Pressure piece	1
KL-0174-0090	Plastic case 780x450x175 mm (empty)	1

Note: Additionally, the KL-0045-70 Hydraulic Spindle can also be stored in the Case

KL-0042-90 K



Note:
The Set is delivered within a Plastic Storage Case

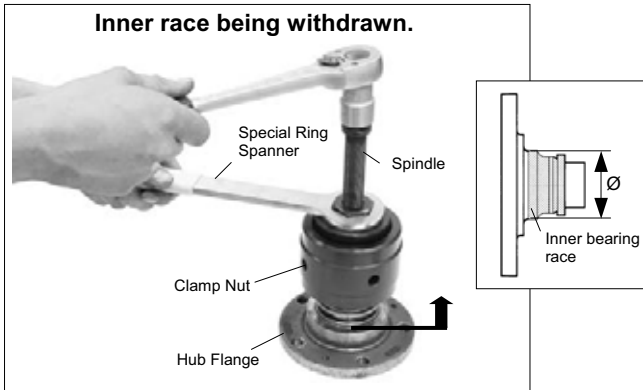

KL-0042-91 K



Note:
The Set is delivered within a Plastic Storage Case

KL-0042-92 K

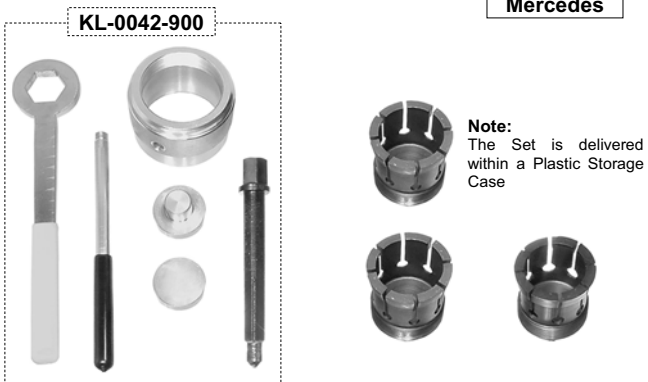

Note:
The Set is delivered within a Plastic Storage Case

KL-0042-90 K Inner Bearing Race Puller Set

Allows precise extraction of the Inner Bearing Race from the Wheel Hub.

Removal of the Hub almost always leaves the inner race on the Hub. The Race is impossible to remove without the correct special tool. Makeshift methods such as Grinders, Chisels, Welding Torches, etc. represent severe risks of personal injury or damage to the components.

The new Puller Set **KL-0042-90 K** allows quick and easy removal of inner bearing races with diameters from 44 mm to 72 mm within a few minutes without risk of damage or injury.

For VW-Audi, BMW, Ford, Fiat, Mercedes, Opel, Renault, Seat, Škoda, Porsche, Peugeot, Volvo etc.

Specification:

Part No.	Description	Qty.
KL-0042-90 K	Inner Bearing Race Puller Set	1
<i>consists of:</i>		
KL-0042-900	Puller Tool Body	1
KL-0042-9031	Chuck size 3 Ø 44 - 48 mm (e.g. Lancia Cappa, Renault etc.)	1
KL-0042-9041	Chuck size 4 Ø 48 - 52 mm (e.g. Ford Transit, T330 etc.)	1
KL-0042-9051	Chuck size 5 Ø 52 - 56 mm (e.g. VW-Audi, Seat, Škoda etc.)	1
KL-0042-9061	Chuck size 6 Ø 56 - 60 mm (e.g. Mercedes W168)	1
KL-0042-9071	Chuck size 7 Ø 60 - 64 mm (e.g. Mercedes W201, W202, W203, W210, W124, BMW, Peugeot etc.)	1
KL-0042-9081	Chuck size 8 Ø 64 - 68 mm (e.g. Mercedes W163, W140, W169, W211, W220, W245, W124T)	1
KL-0042-9091	Chuck size 9 Ø 68 - 72 mm (e.g. VW Touareg, Porsche Cayenne etc.)	1
KL-0042-9099	Plastic storage case (without illustration)	

KL-0042-900 Puller Tool Body

consists of:

Part No.	Description	Part No.	Description
KL-0042-9001	Chuck	KL-1381-2004	Protective Handle 25 x 8
KL-0042-9002	Handle	KL-0174-817	Spindle with Pin (M20x1,5)
KL-0042-9003	Protective Handle Ø 14mm	KL-0174-851	Pressure Piece for Hubs
KL-0042-9004	Special Ring Spanner 36mm	KL-0174-854	Pressure Piece for Hubs

Inner Bearing Race Puller (not ill.)

KL-0042-903 Inner Bearing Race Puller

Suitable for inner races -Ø 44 - 48 mm. (e.g. Lancia Cappa, Renault etc.)
Consists of KL-0042-900 and KL-0042-9031

KL-0042-904 Inner Bearing Race Puller

Suitable for inner races -Ø 48 - 52 mm. (e.g. Ford Transit, T330 etc.)
Consists of KL-0042-900 and KL-0042-9041

KL-0042-905 Inner Bearing Race Puller

Suitable for inner races -Ø 52 - 56 mm. (e.g. VW-Audi, Seat, Škoda etc.)
Consists of KL-0042-900 and KL-0042-9051

KL-0042-906 Inner Bearing Race Puller

Suitable for inner races -Ø 56 - 60 mm. (e.g. Mercedes W168 etc.)
Consists of KL-0042-900 and KL-0042-9061

KL-0042-907 Inner Bearing Race Puller

Suitable for inner races -Ø 60 - 64 mm. (e.g. Mercedes W201, W202, W203, W210, W124, BMW, Peugeot etc.)
Consists of KL-0042-900 and KL-0042-9071

KL-0042-908 Inner Bearing Race Puller

Suitable for inner races -Ø 64 - 68 mm. (e.g. Mercedes W163, W140, W169, W211, W220, W245, W127T)
Consists of KL-0042-900 and KL-0042-9081

KL-0042-909 Inner Bearing Race Puller

Suitable for inner races -Ø 68 - 72 mm. (e.g. VW Touareg, Porsche Cayenne etc.)
Consists of KL-0042-900 and KL-0042-9091

KL-0042-91 K Inner Bearing Race Puller Set

As **KL-0042-90 K** but consists of the Base tool **KL-0042-900**, the Chucks size 4 **KL-0042-9041** and size 5 **KL-0042-9051** and the Plastic Storage Case **KL-0042-9099**.

Universal application for Inner Bearing Races with Ø 48 mm - 56 mm.

KL-0042-92 K Inner Bearing Race Puller Set

As **KL-0042-90 K** but consists of the Base tool **KL-0042-900**, the Chucks size 6 **KL-0042-9061**, size 7 **KL-0042-9071**, size 8 **KL-0042-9081** and the Plastic Storage Case **KL-0042-9099**.

Universal application for Inner Bearing Races with Ø 56 mm - 68 mm.

KL-0155-9

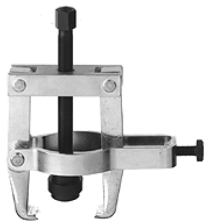

VW-Audi, Seat

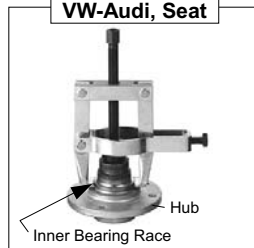

KL-0155-9 Twin-Arm Bearing Puller

With clamping bridge and pushing adaptor. Especially for extracting the inner bearing race on **VW-Audi** cars.

Technical Data:

Part No.	⇄ [mm]	⇅ [mm]	Weight [kg]
KL-0155-9	90	100	1,65

KL-0252-10



VW-Audi, Seat



KL-0252-10 Inner Bearing Race Puller

To remove the inner bearing race of front wheel hubs on **Golf IV** with ABS brakes.

KL-0042-1 K



Universal

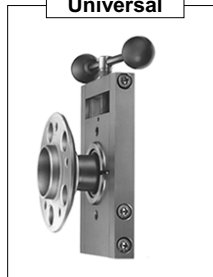

KL-0042-1 K Universal Inner Bearing Race Extractor

Suitable for **VW-Audi, Opel/Vauxhall, BMW, Fiat, Seat, Mercedes, Renault, Peugeot, Citroën, etc.** as well as **Japanese cars.**

Wheel-bearing inner races may be quickly, cleanly and safely removed from the hub using the **KL-0042-1 K universal** tool. Further Chuck-Jaws are available upon request.

Each Chuck-Jaw has a turned profile which corresponds exactly to the inner race, or a lip which can engage behind the race. For inner races that cannot be gripped in the race-profile or in an alternative groove, we offer the Chuck-Jaws **KL-0042-0045**, which are formed with a knife-edge to separate the inner-race from the hub.

Advantages

- Universal due to inter-changeable Chuck-Jaws.
- Quick, safe, clean ⇒ cost-savings.
- Hardened components ⇒ wear-resistant.
- Robust construction, may be used safely in Hydraulic Presses.
- Hammers, Chisels, Welding Torches and Angle-grinders are not required ⇒ no risks of accidents.

Examples for inner race withdrawn.

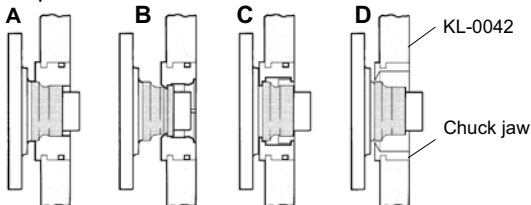

KL-0042 Tool body without chuck jaws

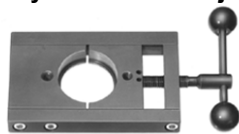

Accessories for KL-0042

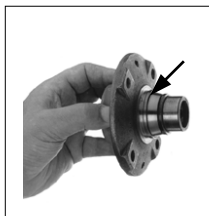
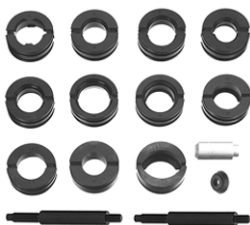

Inner race extraction using either 2-Arm Puller or in conjunction with **KL-0174 Series.**



Part No.	Description	Qty.
KL-0042-1K	Inner Bearing Ring Extractor	1
<i>consists of:</i>		
KL-0042	Inner Bearing Ring Extractor (Tool Body)	1
KL-0042-0010	Pair of Chuck-Jaws for VW-Audi	1
KL-0042-0015	Pair of Chuck-Jaws for Opel/Vauxhall	1
KL-0042-0016	Pair of Chuck-Jaws for Opel/Vauxhall, BMW	1
KL-0042-0025	Pair of Chuck-Jaws for Mercedes	1
KL-0042-0045	Pair of universal Chuck-Jaws	1
KL-0042-0060	Plastic storage case - empty	1

KL-0042 Inner Bearing Race Extractor

As **KL-0042-1 K** but without chuck jaws and case.

Accessories:

Part No.	Chuck-jaws for	Part No.	Chuck jaws for
KL-0042-0010	VW-Audi	KL-0042-0026	Mercedes W140 (S-Class)
KL-0042-0015	Opel/Vauxhall	KL-0042-0030	BMW and VW
KL-0042-0016	Opel/Vauxhall, BMW	KL-0042-0040	Peugeot
KL-0042-0017	Opel/Vauxhall	KL-0042-0041	Peugeot, Renault
KL-0042-0020	Fiat and Seat	KL-0042-0045	Universal
KL-0042-0021	Fiat	KL-0042-0050	Drift
KL-0042-0025	Mercedes	KL-0041-3006	Pressure Disc
KL-0174-726	Bolts M12x1,75 (each) For KL-0174... Series	KL-0042-0060	Empty case (not ill.)

Use of the **KL-0174-...Series** requires 2 Bolts **KL-0174-726** and 2 Nuts **KL-0174-701**.

KL-0232-1

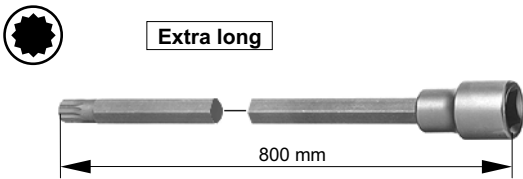

KL-0232-1 Special Socket xZN M8

For loosening the screws at the drive shaft quick and easy from outside.

→ Increased job time saving.

Not permitted for the use of impact guns.

Suitable for **VW-Audi**, etc.

Length: 800 mm Drive: 1/2"□

KL-0232-2

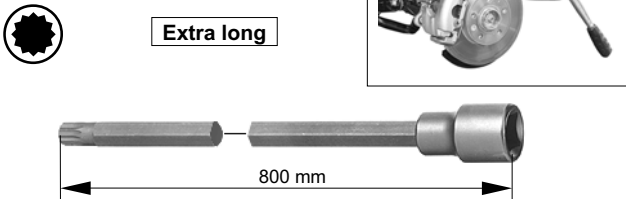

KL-0232-2 Special Socket xZN M10

Application as **KL-0232-1**.

Especially for **VW Golf IV** etc.

Length: 800 mm Drive: 1/2"□

KL-0232-3

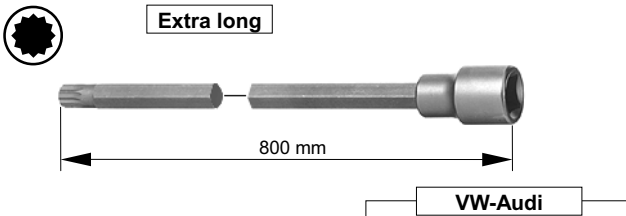

KL-0232-3 Special Socket xZN M12

Application as **KL-0232-1**.

Especially for **VW T4, Touareg** etc..

Length: 800 mm Drive: 1/2"□

KL-0232-4

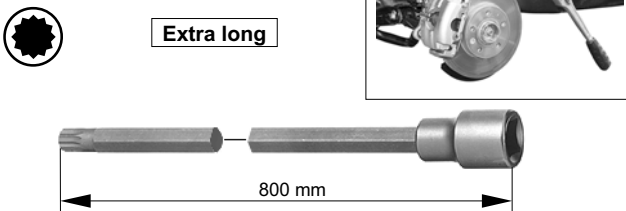

KL-0232-4 Special Socket xZN M14

Application as **KL-0232-1**.

Especially for **VW T4, Touareg** etc.

Length: 800 mm Drive: 1/2"□

KL-0233-1

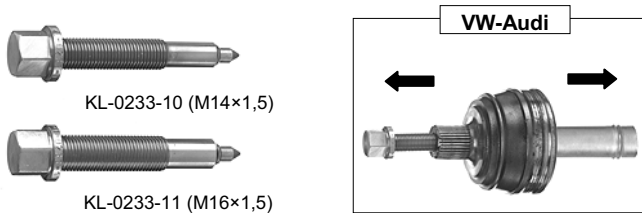

KL-0233-1 CV Joint Pressure Bolts

Suitable for **VW-Audi**.

This tool allows the quick and easy removal of the Constant Velocity Joint on the Drive Shaft. (Not suitable for sleeve shafts.)

Weight: 595 g

consists of:

Part No.	Description
KL-0233-10	Pressure screw M14x1,5
KL-0233-11	Pressure screw M16x1,5

KL-0049-3014

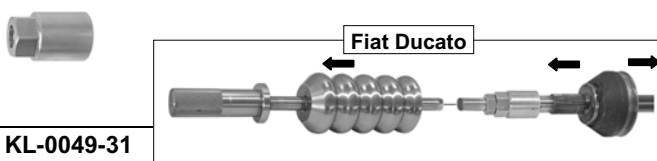

KL-0049-3014 Adaptor M28x1,5

Suitable for **Fiat Ducato**.

The Adaptor **KL-0049-3014** allows quick and easy separation of the outer Constant Velocity Joint on Drive Shafts in conjunction with the slide hammer **KL-0049-31**.

Hex.: 32 mm Ø: 40 mm
Length: 65 mm Connection thread:..... M18

KL-0049-31



KL-0049-31 Slide Hammer

For Half-Shafts, Drive Shafts, Brake Discs and Brake drums, etc. including Adaptor 2 1/4"-14UNS to M18 suitable for the **KL-0174-Series**.

Hammer weight: 4,8 kg Length: 690 mm

KL-0177-2

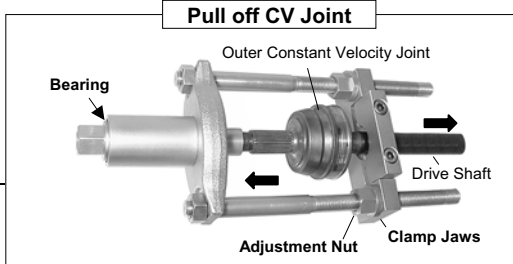
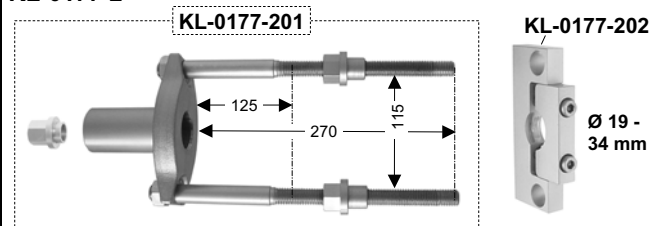

KL-0177-21

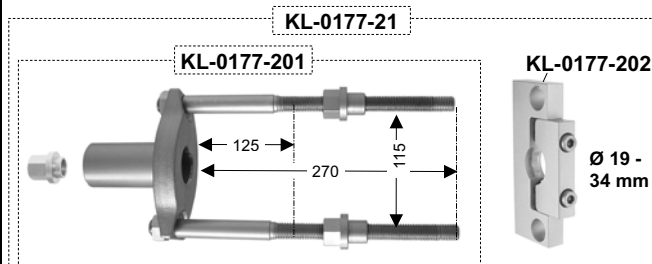

Accessories (To use on further vehicles)

Press spindles:

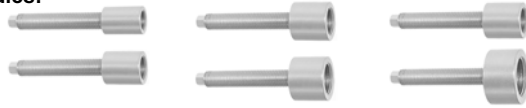

Housing:

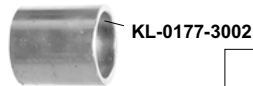

KL-0177-3

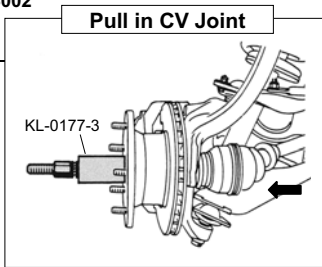
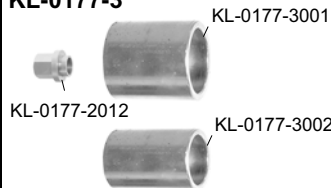

KL-0177-2 CV Joint Splitter (Pat.)

(Pat.)

Allows quick and easy separation of the outer Constant Velocity Joint on Drive Shafts. *The operation can be performed without removing the Drive Shaft from the vehicle.* (On some cars it is not possible to pull off the CV Joint) ⇒ Important when changing the Gaiter or CV Joint.

The various Spindles ensure that this tool is universally suitable for a wide range of vehicles - **VW-Audi, Opel/Vauxhall, Jap. vehicles, etc.**

Advantages:

- High time savings
- Prevents accidents
- Eliminates damage to components caused by Hammers, Chisels, etc.
- Universal application.

consists of:

Part No.	Description	Qty.
KL-0177-201	Press Frame	1
KL-0177-202	Set of Clamp Jaws Ø 19 - 34 mm	1
KL-0177-205	Set of Spindles	1
KL-0177-205	Set of Spindles	1
consists of:		
KL-0177-2051	Spindle M16x1,5 inner thread (outer Ø20)	1
KL-0177-2052	Spindle M18x1,5 inner thread (outer Ø22)	1
KL-0177-2053	Spindle M20x1,5 inner thread (outer Ø23)	1
KL-0177-2054	Spindle M22x1,5 inner thread (outer Ø25)	1
KL-0177-2055	Spindle M24x1,5 inner thread (outer Ø28) BMW	1
KL-0177-2056	Spindle M27x1,5 inner thread (outer Ø30) BMW	1
KL-0177-2057	Spindle M30x1,5 inner thread (outer Ø35) BMW	1
KL-0177-2061	Spindle M14x1,5 outer thread VW-Audi	1
KL-0177-2062	Spindle M16x1,5 outer thread VW-Audi	1

KL-0177-21 CV Joint Splitter and drive shaft insertion tool (Pat.)

(Pat.)

Suitable for VW-Audi, Seat, Skoda etc.

For pulling the constant-velocity joint off the half-shaft and pulling the half-shaft into the wheel hub.

⇒ Suitable for both solid and hollow half-shafts.

Application

Allows quick and easy separation of the outer Constant Velocity Joint on Drive Shafts. *The operation can be performed without removing the Drive Shaft from the vehicle.* (On some cars it is not possible to pull off the constant-velocity joint)

⇒ Important when changing the Gaiter or constant-velocity joint.

Housing **KL-0177-3001**, shouldered nut (**KL-0177-2012** M18, 27 mm across jaws) and the appropriate puller spindle are used to pull the half-shaft into the wheel hub. This tool is needed for vehicles on which the half-shafts are a very tight fit in the wheel hub.

Various housings and puller spindles make this tool universal in use, for instance on e.g. **BMW, Mercedes, Opel, Renault, Peugeot, Seat, Skoda, VW-Audi, jap. vehicles, etc.**

Advantages:

- Large time-saving.
- Reduces risks of accidents
- Eliminates damage to components caused by Hammers, Chisels, etc.
- universal using.
- Suitable for both solid and hollow half-shafts.

consists of:

Part No.	Description	Qty.
KL-0177-201	Press Frame	1
KL-0177-202	Set of Clamp Jaws Ø 19 - 34 mm	1
KL-0177-2061	Spindle M14x1,5 outer thread [e.g. Audi 80, A4]	1
KL-0177-2062	Spindle M16x1,5 outer thread [e.g. Audi A6]	1
KL-0177-2053	Spindle M20x1,5 inner thread (outer Ø23) [e.g. VW Golf IV, Touareg, Porsche Cayenne etc.]	1
KL-0177-3001	Housing (outer Ø39 mm inner Ø29 mm)	1

Accessories Spindles:

- KL-0177-2051 Spindle M16x1,5 inner thread (outer Ø20)
- KL-0177-2052 Spindle M18x1,5 inner thread (outer Ø22)
- KL-0177-2054 Spindle M22x1,5 inner thread (outer Ø25) [e.g. BMW E30]
- KL-0177-2055 Spindle M24x1,5 inner thread (outer Ø28) [e.g. BMW E36, Mercedes W203]
- KL-0177-2056 Spindle M27x1,5 inner thread (outer Ø30) [e.g. BMW E32, E34, E38, E39]
- KL-0177-2057 Spindle M30x1,5 inner thread (outer Ø35) [e.g. BMW E32, E34, E36]

Accessories Housing:

- KL-0177-3002 - Housing (outer Ø46 mm inner Ø36 mm) (e.g. BMW)

KL-0177-3 Drive Shaft Insertion Tool

To draw the Drive Shaft into the Hub Splines. Required for those vehicles with tight tolerances between Hub and Drive Shaft splines. Various Spindles ensure universal application, e.g. **VW-Audi, BMW, Mercedes, Opel/Vauxhall, Renault, Peugeot etc.**

consists of:

Part No.	Description	Part No.	Description
KL-0177-3001	Housing o.-Ø39 mm i.-Ø 29 mm	KL-0177-2012	Shoulder nut
KL-0177-3002	Housing o.-Ø46 mm i.-Ø 36 mm	KL-0177-205	Set of spindles

KL-0415-1

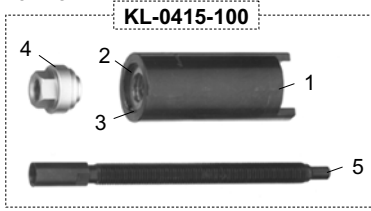

VW-Audi, BMW, Mercedes



KL-0415-1 Puller for drive shafts with 1 Adaptor

For pulling drive-shafts into hubs or for extracting hubs. Essential for **BMW E36 and Mercedes W203**, etc.

Pos.	Part No.	Description	Qty.
	KL-0415-1	Puller for drive shafts (BMW and Mercedes)	1
	<i>consists of:</i>		
8	KL-0415-0008	Adaptor M24x1,5 (e.g. BMW E36, Mercedes W203)	1
	KL-0415-100	Puller, base tool	1
Pos.	Part No.	Description	Qty.
	KL-0415-100	Puller, base tool	1
	<i>consists of:</i>		
1	KL-0415-0001	Housing	1
2	KL-0040-3004	Axle Bearing	1
3	KL-0040-3005	Snap ring SB 35	1
4	KL-0415-0004	Locking nut	1
5	KL-0415-0005	Spindle	1

KL-0415-2

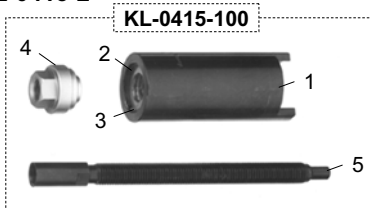

VW-Audi, BMW, Mercedes



KL-0415-2 Puller for drive shafts with 4 Adaptors

For pulling drive-shafts into hubs or for extracting hubs. Essential for **BMW (E30, E32, E34, E36 E38, E39, etc.) and Mercedes (W203 etc.)**

Pos.	Part No.	Description	Qty.
	KL-0415-2	Puller for drive shafts (BMW and Mercedes)	1
	<i>consists of:</i>		
8	KL-0415-0008	Adaptor M24x1,5 (e.g. BMW E36, Mercedes W203)	1
9	KL-0415-0009	Adaptor M30x1,5 (e.g. BMW E32, E34, E36)	1
10	KL-0415-0010	Adaptor M22x1,5 (e.g. BMW E30, E46)	1
11	KL-0415-0011	Adaptor M27x1,5 (e.g. BMW E32, E34, E38, E39, X5)	1
	KL-0415-100	Puller, base tool	1
Pos.	Part No.	Description	Qty.
	KL-0415-100	Puller, base tool	1
	<i>consists of:</i>		
1	KL-0415-0001	Housing	1
2	KL-0040-3004	Axle Bearing	1
3	KL-0040-3005	Snap ring SB 35	1
4	KL-0415-0004	Locking nut	1
5	KL-0415-0005	Spindle	1

KL-0415-4

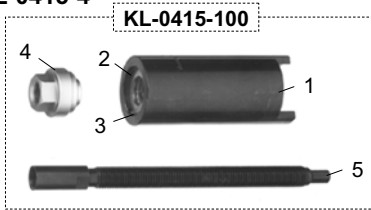

VW-Audi, BMW, Mercedes



KL-0415-4 Puller for drive shafts with 6 Adaptors

For pulling drive-shafts into hubs or for extracting hubs. Essential for **VW-Audi (Touareg etc.), BMW (E30, E32, E34, E36 E38, E39, etc.), Mercedes (W203 etc.) and Porsche (Cayenne etc.)**

Pos.	Part No.	Description	Qty.
	KL-0415-4	Puller for drive shafts (VW-Audi, BMW, Mercedes and Porsche)	1
	<i>consists of:</i>		
6	KL-0415-0006	Adaptor M16x1,5	1
7	KL-0415-0007	Adaptor M20x1,5 (e.g. Porsche Cayenne, VW-Touareg)	1
8	KL-0415-0008	Adaptor M24x1,5 (e.g. BMW E36, Mercedes W203)	1
9	KL-0415-0009	Adaptor M30x1,5 (e.g. BMW E32, E34, E36)	1
10	KL-0415-0010	Adaptor M22x1,5 (e.g. BMW E30, E46)	1
11	KL-0415-0011	Adaptor M27x1,5 (e.g. BMW E32, E34, E38, E39, X5)	1
	KL-0415-100	Puller, base tool	1
Pos.	Part No.	Description	Qty.
	KL-0415-100	Puller, base tool	1
	<i>consists of:</i>		
1	KL-0415-0001	Housing	1
2	KL-0040-3004	Axle Bearing	1
3	KL-0040-3005	Snap ring SB 35	1
4	KL-0415-0004	Locking nut	1
5	KL-0415-0005	Spindle	1

KL-0192-13

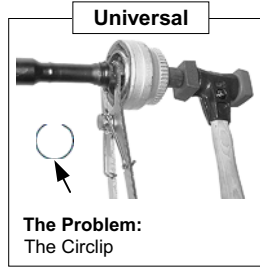
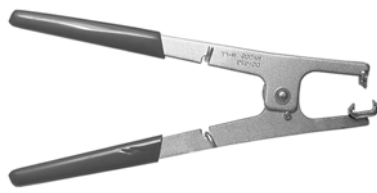

KL-0192-13 Circlip Squeezing Pliers

Suitable for VW-Audi, Ford, Honda, Mazda, Mitsubishi, Nissan, Opel/Vauxhall, Seat, Škoda, Subaru, Suzuki, Toyota, etc.

To pre-tension the drive-shaft circlip during assembly of the outer constant velocity joint.

By holding the drive-shaft circlip with the special circlip pliers **KL-0192-13**, the outer drive-shaft splines can be easily assembled onto the CV Joint.

Weight: 360 g

KL-0192-12

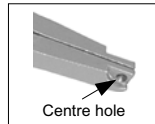

KL-0192-12 Special Circlip Pliers angled

Specially used for Drive-Shafts and CV-Joints, Engines and Transmissions.

Applicable on VW-Audi, Mercedes, Opel/Vauxhall, BMW, Ford, etc.

Part-No.	Application example	Tip-Form	max. opening [mm]	Long [mm]	Wt. [g]
KL-0192-12	very inaccessible or deep-seated Circlips on Drive-Shafts and Steering Shafts	30 degree angled, centering-rand, long, slim	min. 3 max. 35	200	190

KL-0192-825

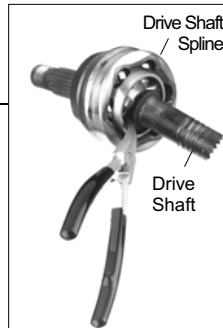

The Problem: Safety Clips

KL-0192-825 Special Circlip Pliers

Specially used for Drive-Shafts and CV-Joints, Engines and Transmissions.

Applicable on VW-Audi, Mercedes, Opel/Vauxhall, BMW, Ford, etc

Part-No.	Application example	Tip-Form	max. opening [mm]	Long [mm]	Wt. [g]
KL-0192-825	deep, large Rings on Drive Shafts and Steering Shafts	straight, centering-rand, long, slim	min. 5 max. 40	240	210

KL-0192-826



KL-0192-826 Special Circlip Pliers

Specially used for Drive-Shafts and CV-Joints, Engines and Transmissions.

Applicable on VW-Audi, Mercedes, Opel/Vauxhall, BMW, Ford, etc.

Part-No.	Application example	Tip-Form	max. opening [mm]	Long [mm]	Wt. [g]
KL-0192-826	large Rings on Drive Shafts and Steering Shafts	straight with Hold profile	min. 6,5 max. 35	225	205

KL-0121-90

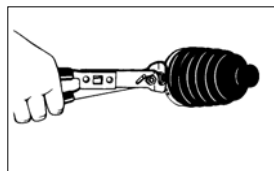

KL-0121-90 Hose Band Pliers

Applicable on Audi, BMW, Chrysler, Ford, GM, Honda, Mazda, Mercedes, Nissan, Opel/Vauxhall, VW, etc.

For tightening of clamps (system Oetiker) on cv boots, water and fuel hoses.

Advantages:

- No damage to spring band clamps.
- No damage to hoses.
- Easy and quick replacement of hoses.

KL-0121-93

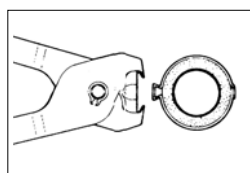

KL-0121-93 Hose Band Pliers

Applicable on Audi, BMW, Chrysler, Ford, GM, Honda, Mazda, Mercedes, Nissan, Opel/Vauxhall, VW, etc.

For tightening of clamps (system Oetiker) on axle collars, water and fuel hoses. **With toggle joint.**

KL-0121-85

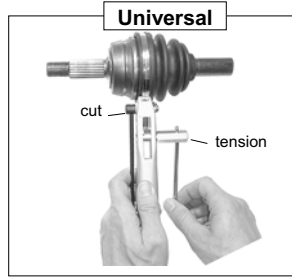

Universal

KL-0121-85 Hose Band Tool

Suitable for Endless Clamp-Bands (e.g. Bandimax) up to 9,5 mm, for example drive-shaft gaiters, etc.

For quick and easy tensioning and cutting endless Clamp-Bands.

Weight: 450 g

KL-0121-86

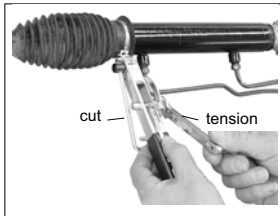

Universal

Ratchet

KL-0121-86 Hose Band Tool with Ratchet

Suitable for Endless Clamp-Bands (e.g. Bandimax) up to 9,5 mm, for example drive-shaft gaiters, etc.

For quick and easy tensioning and cutting endless Clamp-Bands.

Length 200 mm Weight: 360 g

KL-0121-81

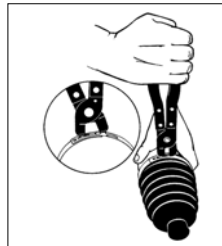

Universal

KL-0121-81 Hose Band Pliers

Works on earless-type Clamp-Bands on axle collars, water and fuel hoses.

Universal Application.

Specially for **VW-Audi etc.**

Weight: 340 g

KL-0121-97

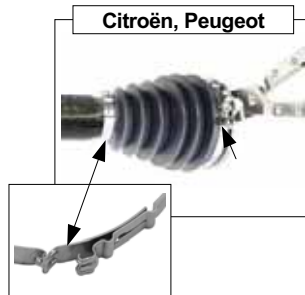

Citroën, Peugeot

KL-0121-97 Hose Band Pliers

Suitable for Citroën, Peugeot etc.

For releasing and re-fitting reusable Clamp-Bands, types CLIC (Caillau/Serflex).

The jaws of these pliers are specially shaped to open and close even Clamp-Bands that are difficult to reach.

KL-0121-96

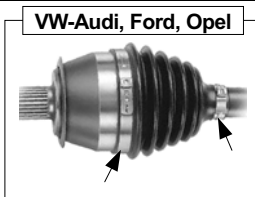

VW-Audi, Ford, Opel

KL-0121-96 Hose Band Pliers with Torque drive

Suitable for VW-Audi, Ford, Opel/Vauxhall etc.

For assembly of new stainless steel Clamp-Bands on drive-shafts where a torque setting is required.

The **4549-05 3/8"** Torque Wrench is ideal to provide the drive.

Spare part: KL-0121-9601 - Replace jaw pair

KL-0121-83

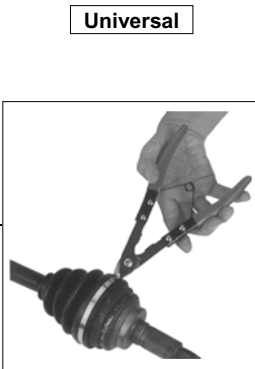

Universal

KL-0121-83 Hose Band Cutter straight

To open or cut "earless" Clamp-Bands on CV-Joints, Drive-Shafts, Radiator Hoses, Fuel-lines, etc.

Universal application.

Technical data:

Length: 220 mm Weight: 340 g

KL-0121-84



KL-0121-84 Hose Band Cutter angled

As **KL-0121-83**

But with angled head for inaccessible locations.

Technical data:

Length: 220 mm Weight: 345 g

KL-0140-74

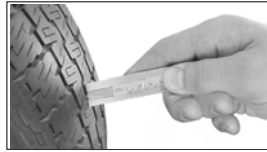

KL-0140-74 Tire Tread Depth Gauge

Strong brass construction.

Weight: 50 g

Range: 30 mm

Legibility: 0,1 mm

KL-0101-10



KL-0101-10 Pliers for Balance Weights

Hard rubber top eliminates any damage to metal rims.

KL-0101-11



KL-0101-11 Pliers for Balance Weights

Without hard rubber top.

KL-0193-10



VW-Audi, Opel



KL-0193-10 Pliers for Protection Top

Suitable for VW-Audi, Opel/Vauxhall, etc.

For the safe removal of plastic tops off of wheel bolts.

KL-0101-22 K



Tapering, with a left-hand thread.

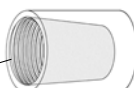

KL-0101-22 K Special Socket Set

To remove security wheel-nuts or bolts when the original security key is missing, also to un-do other hexagonal nuts and bolts which have damaged or „rounded“ heads.

The sockets are specially designed (tapering, and with a left-hand thread) to unscrew and remove screws, nuts and threaded pins without difficulty.

consists of:

Part No.	Description	Ø mm
KL-0101-2201	Special Socket	17 mm
KL-0101-2202	Special Socket	18,5 mm
KL-0101-2203	Special Socket	20 mm
KL-0101-2204	Special Socket	21,5 mm
KL-0101-2205	Special Socket	23 mm
KL-0101-2206	Special Socket	24,5 mm
KL-0101-2207	Special Socket	26 mm
KL-0101-2290	Case (empty)	

KL-0100-54

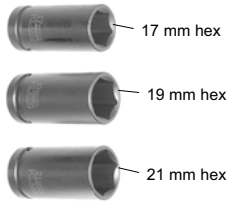

KL-0100-54 Impact Socket Set

Specially for loosening and tightening wheel-nuts.

Technical Data:

Hexagons: 17, 19, 21
 Length: 55 mm
 Drive: 1/2"
 Weight: 440 g

Deep Impact Socket

Slim design, overall length = 100 mm, drive 1/2" for wheel studs, drive shafts, etc.

Part-No.	Socket Size	Part-No.	Socket Size
KL-0100-517	17 mm hex	KL-0100-524	24 mm hex
KL-0100-519	19 mm hex	KL-0100-527	27 mm hex
KL-0100-520	20 mm hex	KL-0100-530	30 mm hex
KL-0100-521	21 mm hex	KL-0100-532	32 mm hex
KL-0100-522	22 mm hex		

KL-0100-517 - KL-0100-532

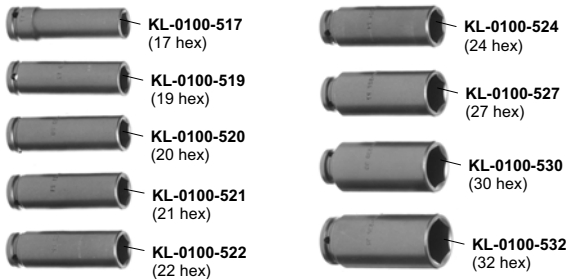

KL-0100-56 K Impact Socket Set with protective outer sleeve

In extra long and thin-wall form, with plastic protective sleeve. Specially for loosening and tightening wheel-nuts on light-alloy wheels.

Technical Data:

Hexagons: 17, 19, 21
 Length: 85 mm
 Drive: 1/2"
 Weight: 920 g

Accessories: (not illustrated)

Part No:	Description:	Qty:
KL-0100-5617-S	Plastic outer sleeve for 17 mm (blue)	1
KL-0100-5619-S	Plastic outer sleeve for 19 mm (green)	1
KL-0100-5621-S	Plastic outer sleeve for 21 mm (red)	1

KL-0100-56 K



KL-0115

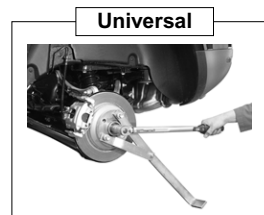

KL-0115 Wheel Hub Locking Tool

Application for almost all passenger cars and light commercial vehicles.

Drive shaft retaining nuts and hub bearing nuts may be easily removed - even with the vehicle off the ground, and can also be replaced using the correct torque setting.

Length: 620 mm

Note: Special 12 point Sockets for removal and replacement of retaining nuts see Page 3.5-05.

KL-0100-Series

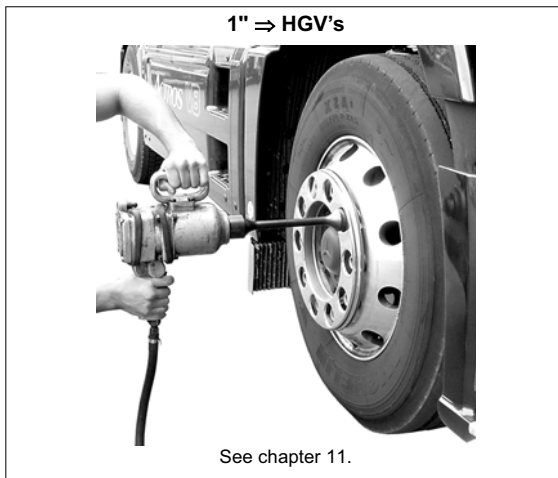
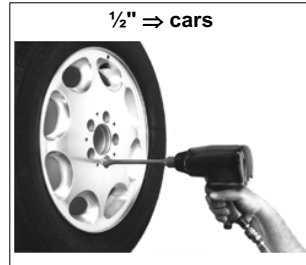

See chapter 11.

KL-0100-Series Accu Torq Impact Sockets

AccuTorq Impact Sockets are designed to be used in conjunction with a 1/2"-drive impact gun to tighten vehicle wheel-nuts to pre-determined torque limits according to manufacturers specifications.

AccuTorqs work by absorbing excessive torque into a torsion bar spring which will release the stored energy by rotating the anvil of the impact gun backwards during the intervals between hammer blows.

AccuTorqs work by "wasting" the excess torque generated by air impact guns, as all torque above the rated limited of any given AccuTorq will deflect the shaft (torsion bar spring) between the 1/2" input end and the hexagonal output end of the AccuTorq.

Warranty:

The manufacturer offer 12 months unconditional warranty on the torsion bar shaft but in common with all manufacturers of impact sockets no warranty can be offered on the 1/2" drive or hexagonal drive.

Special Features:

- **Combines impact gun speed with torque-wrench accuracy.**
- **Fits all 1/2" air impact guns with min. 220 Nm (1"- air impact guns with min. 1 400 Nm).**
- **Maintenance free, no need for calibration adjustments.**
- **Colour coded for easy identification of size and torque-limit (AccuTorqs for lorries are black).**

Technical Data:

Drive 1/2", Length 220 mm, Weight per 0,3 kg, for cars.

Part No.	Description	Hex.	Nm*
KL-0100-10	Accu Torq Socket (green) e.g. Renault, Skoda, Suzuki.	17	75
KL-0100-11	Accu Torq Socket (beige) e.g. Opel, Renault.	17	95
KL-0100-12	Accu Torq Socket (red) e.g. Audi, BMW, Mercedes, Opel, Porsche, VW.	17	110
KL-0100-13	Accu Torq Socket (navy) e.g. Alfa Romeo, Citroën, Fiat, Honda, Hyundai, Peugeot, Renault, Rover.	19	75
KL-0100-14	Accu Torq Socket (yellow) e.g. Alfa Romeo, Citroën, Fiat, Ford, Lada, Opel, Peugeot, Renault, Rover, Volvo.	19	90
KL-0100-15	Accu Torq Socket (blue) e.g. Alfa Romeo, Fiat, Ford, Honda, Hyundai, Isuzu, Kia, Mercedes, Rover, Saab, Volvo.	19	110
KL-0100-16	Accu Torq Socket (grey) e.g. Ford, Porsche.	19	135
KL-0100-17	Accu Torq Socket (black) e.g. Mitsubishi, Rover.	21	80
KL-0100-18	Accu Torq Socket (light brown) e.g. Daihatsu, Ford, Mazda, Mitsubishi, Nissan, Toyota.	21	110
KL-0100-19	Accu Torq Socket (pink) e.g. Ford.	21	95
KL-0100-20	Accu Torq Socket (creme) e.g. Audi A4, A6, A8, Skoda Oktavia	17	120
KL-0100-21	Accu Torq Socket (lemon) e.g. Mercedes S-Class	17	150
KL-0100-22	Accu Torq Socket (lime) e.g. Fiat Ulysse & Multipla	19	100
KL-0100-23	Accu Torq Socket (lilac) e.g. Mercedes M-Class	19	150
KL-0100-24	Accu Torq Socket (dark green) e.g. Jaguar XJS-Serie, X300 & XK8 (steel wheels only)	22	80
KL-0100-25	Accu Torq Socket (orange) e.g. Jaguar XJS-Serie, X300 & XK8 (alloy wheels only)	22	100

KL-0100-1000	Accu Torq rack		
--------------	----------------	--	--

* = Torque/Moment of Torsion

Note: Accu Torq Socket Set for HGV's see HGV Chapter-Pages.

3550-20

RAHSOL
DREMOTEC

1/2" push-through square drive for bi-directional tightening.



1/2"

20-200 N·m

TORCOFLEX K

Code No.:	1379526
Part No.:	3550-20
Weight:	1250 g
Length:	485 mm
Head Ø	44 mm
Head height / length	22 mm
Range of work / measurement 1, Nm (min/max):	20-200
Range of work / measurement 2, lbf-ft (min/max):	15-150
Scale divisions:	10 N·m

4550-20

1/2" interchangeable mushroom head-square drive for bi-directional tightening



1/2"

20-200 N·m

TORCOFIX K

Code No.:	7601610
Part No.:	4550-20
Weight:	1100 g
Length:	485 mm
Head Ø	44 mm
Head height / length	22 mm
Range of work / measurement 1, Nm (min/max):	20-200
Range of work / measurement 2, lbf-ft (min/max):	15-150
Scale divisions:	1 N·m

5550-20

1/2" reversible ratchet with integrated lever for bi-directional tightening



1/2"

40-200 N·m

TORCOFIX UK

Code No.:	1210475
Part No.:	5550-20
Weight:	1200 g
Length:	500 mm
Head Ø	44 mm
Head height / length	22 mm
Range of work / measurement 1, Nm (min/max):	40-200
Range of work / measurement 2, lbf-ft (min/max):	15-150
Scale divisions:	1 N·m

8573-00



1/2"

40-200 N·m

DREMOMETER BC

Code No.:	7685530
Part No.:	8573-00
Weight:	1,4 kg
Length:	553 mm
Range of work / measurement 1, Nm (min/max):	40-200
Range of work / measurement 2, lbf-ft (min/max):	30-150
Scale divisions:	5 N·m / 5 lbf-ft

Example for Torque Wrench:

TORCOFIX K 4549-01 ⇒ 1-5 N·m ⇒ 1/4"

TORCOFIX K 4549-02 ⇒ 2-25 N·m ⇒ 1/4"

TORCOFIX K 4549-05 ⇒ 5-50 N·m ⇒ 3/8"

TORCOFLEX K Torque Wrench

Use:

- Controlled screw tightening.
- For use in all areas of industrial manufacturing

Features:

- Adjustable torque wrench with square drive and integrated ratchet-head function
- For controlled bi-directional tightening
- 1/2" push-through square drive with ball-locking mechanism as per DIN 3120 - A 12.5, ISO 1174
- In accordance with DIN EN ISO 6789, traceable to national norms
- Lever-breaking mechanism with a castor guarantee tactile-impulse and audible actuation signals
- Actuation accuracy: +/- 3% tolerance of the scale set torque
- Robust, powder-coated steel tube construction with zinc-plated ratchet head
- Double scale N·m and lbf-ft underneath a window with a magnifying-glass effect
- N·m graduation of 10 N·m
- Black plastic handgrip with slip-resistant grained surface

3

TORCOFIX K Torque Wrench

As TORCOFLEX K but with:

- 1/2" interchangeable mushroom head-square drive with ball-locking mechanism
- Robust, silk-matt chrome-plated steel tube construction, with chrome-plated ratchet head and glass-fibre-reinforced plastic parts
- Additional micrometer scale with N·m graduation of 1 N·m
- With an indentation in the middle of the handgrip as a calibration aid

TORCOFIX UK Torque Wrench

As TORCOFLEX K but with:

- Adjustable torque wrench with 1/2" square drive and integrated reversible ratchet-head function
- Robust, silk-matt chrome-plated steel tube construction, with chrome-plated ratchet head and glass-fibre-reinforced plastic parts
- Additional micrometer scale with N·m graduation of 1 N·m
- With an indentation in the middle of the handgrip as a calibration aid

DREMOMETER BC Torque Wrench















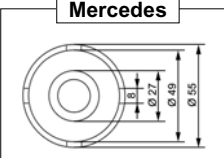

Use:

- Controlled screw tightening in the range 40 - 200 N·m
- Ideal for the automotive industry
- Utilisation in all areas of industrial manufacturing

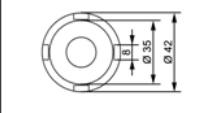
Features:

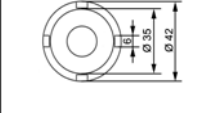
- Adjustable torque wrench with 1/2" single square drive for controlled clockwise tightening (type BC no. 8573)
- 1/2" square drive with ball-locking mechanism DIN 3120 - A 12.5, ISO 1174
- In accordance with DIN EN ISO 6789, traceable to national norms
- Automatic short-path actuation with tactile impulse and audible signal
- Actuation accuracy: +/- 3% tolerance of the scale set torque
- Full-metal construction from high-strength aluminium alloy
- Double scale with a scale graduation of 5 N·m and 5 lbf-ft
- If ordering with pre-set-value locking and safety device lease specify the N·m value - if fixed factory-pre-setting is desired (price on request)

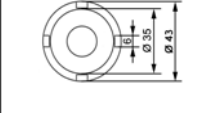
Further RAHSOL DREMOTEC Products and Torque Wrenches see GEDORE catalogue

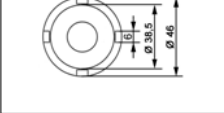
KL-0304		30mm bihex Mercedes, BMW 
KL-0305		32 mm bihex
KL-0307		34 mm bihex Universal 
KL-0306		36 mm bihex
KL-0308		35 mm hex
KL-0301		Mercedes 
KL-0302		Mercedes 
KL-0303		Mercedes 
KL-0303-10		Mercedes 
KL-0303-11		Mercedes 

Special 12 Point Sockets

The special 12 point Sockets are suitable for removal and replacement of retaining nuts on front and rear axles, gearboxes and differentials.

KL-0304 Special 12-Point Socket

30 mm bihex
For BMW E36, E46; Citroen Saxo; Ford Galaxy; Mercedes W123, W124, W126, W129, W201, W203, W211; Opel Astra F, Astra G; Renault Scenic, Clio, Kangoo; Toyota Avensis, Picnic and VW Golf III, Golf IV, Lupo, Touareg, T5 etc.

Drive: 1/2"□ Length:..... 80 mm Weight: 350 g

KL-0305 Special 12-Point Socket

32 mm bihex
For Fiat Punto; Ford Escort, Mondeo; Mercedes W140; Nissan Almera; Opel Astra H, Vivaro; Subaru Outback etc.

Drive: 1/2"□ Length:..... 75 mm Weight: 450 g

KL-0307 Special 12-Point Socket

34 mm bihex
For Fiat Marea, Lancia Lybra, Renault etc.

Drive: 1/2"□ Length:..... 90 mm Weight: 600 g

KL-0306 Special 12-Point Socket

36 mm bihex
For Audi; BMW E36, E39, X5; Ford Transit; Seat Ibiza, Cordoba; Nissan Primera; VW Polo, Golf V, Touareg etc.

Drive: 1/2"□ Length:..... 90 mm Weight: 650 g

KL-0308 Special 6-Point Socket

35 mm hex
For Peugeot 307, 407, 806 etc.

Drive: 1/2"□ Length:..... 75 mm Gewicht:..... 600 g

KL-0301 Toothed Socket

For Mercedes W116, W123, W126 Rear Axle Drive Flange.

Drive: 1/2"□ Length:..... 80 mm Weight: 420 g

KL-0302 Toothed Socket

For Mercedes Gearbox Flange.

Drive: 1/2"□ Length:..... 70 mm Weight: 440 g

KL-0303 Toothed Socket

For Mercedes Differential Flange.

Drive: 1/2"□ Length:..... 70 mm Weight: 370 g

KL-0303-10 Toothed Socket

For Mercedes G-Class (W460 / W461 / W463) Front Axle Wheel Bearing.

Drive: 1/2"□ Length:..... 70 mm Weight: 370 g

KL-0303-11 Toothed Socket

For Mercedes G-Class (W460 / W461 / W463) Front Axle Wheel Bearing.

Drive: 1/2"□ Length:..... 70 mm Weight: 370 g