

### The KLANN Spring Compressors !!!!!

#### The new Stationary Spring Compressor KL-5501

(see page 1-03 - 1-05)

- *Variably adjustable.*
- *No additional tool required.*
- *Universally suitable for springs and shock absorbers.*



#### Telescopic Spring Compressors KL-9002 / KL-9001

(see page 1-06 - 1-11)



- *Stable:  
Max. Load 27500 N*
- *Mobile: can be directly applied to vehicles or to workbenches.*

#### Spring Compressor KL-0015

(see page 1-12 - 1-17)



- *Compact:  
applied to vehicles.*

#### Universal Spring Compressors KL-0021 / KL-0025-1

(see page 1-18 - 1-21)



- *Universal:  
for wishbone  
suspensions and  
multi-arm axles.*

## ➡ The new Stationary KLANN Spring Compressor KL-5501 !!!!! ⬅

### ➤ Universal use for all MacPherson- and Semi-Struts!

E.g. with standard springs, right or left winded springs, excentrical springs or spring plates, conical springs, springs with small number of windings, high or different steepness of the coil winding.

As the spring is compressed with the upper spring plate in direction to the lower spring plate, neither are the shape nor the steepness of the coil windings of any interest.

### ➤ No further accessories needed!

Due to the special design of the jaws, the radial arms, respectively the swivelling bar, all the above mentioned Struts and Semi-Struts can be compressed without any additional accessories.

### ➤ No damage to the Strut tube!

The special strut vise can be adjusted, through a knurled nut, quick and easy up to the correct diameter of the strut tube. (The tensioning bars should be parallel to each other). The clamping jaws are equipped with protective inserts.

### ➤ One-Man-Operation!

The whole working operation can be done by one man only!

⇒ The Strut tube fixation unit is equipped with a quick locking and one-hand-operation device.

### ➤ Mobile due to the workshop trolley!

The Stationary Spring Compressor is equipped with a fixation plate that allows to fix the Spring Compressor on a workshop trolley or a workbench

In combination with a workshop trolley it is possible to work beside the car.



1

### ➡ The new Stationary KLANN Spring Compressor KL-5501 !!!!! ⚡

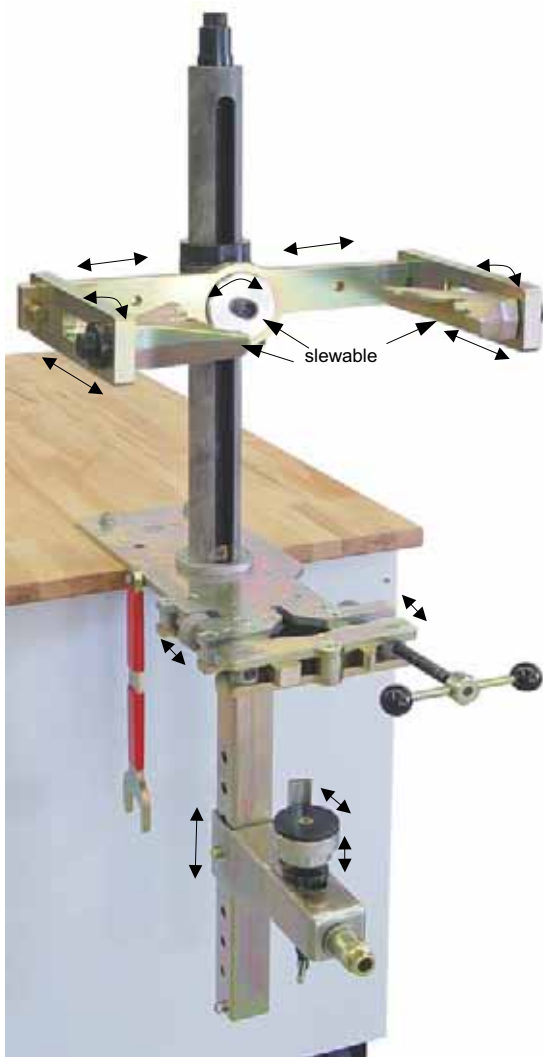

➤ Variable adjustability for all MacPherson- and Semi-Struts.

➤ Clean, safe and efficient way of working.

➤ Easy handling.



### ➡ The new Stationary KLANN Spring Compressor KL-5501 !!!!! ⚡

**Dismounting ⇒  
Compressing the spring.**

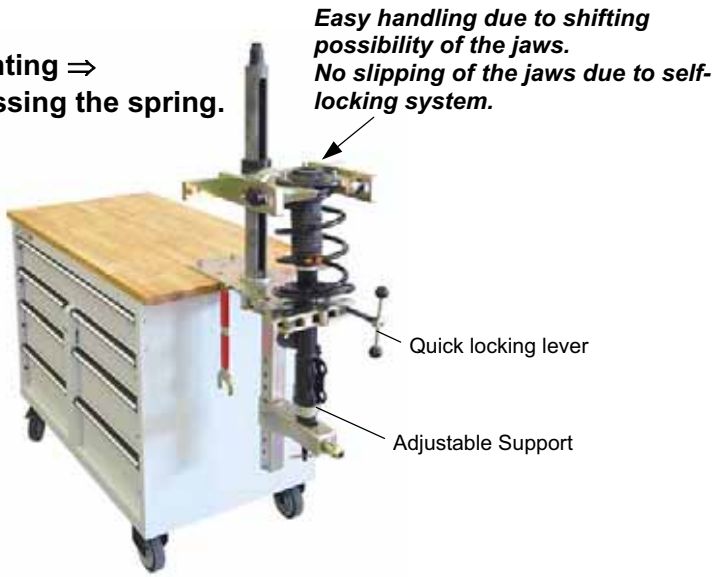

(German Utility Model)

**Dismounting: ⇒  
Spring is compressed.**

*Very short way of compression needed.*

Bolted connection is loosened, bearing plate can be dismantled.

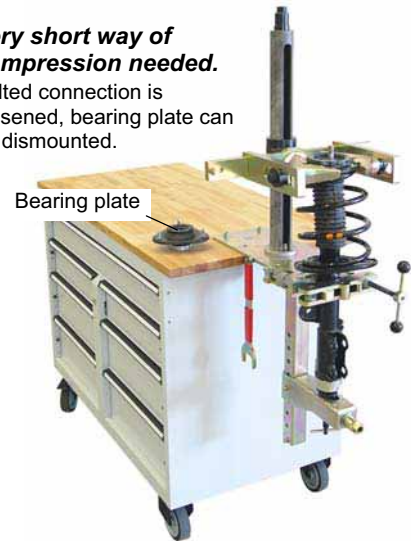

**Mounting: ⇒  
Positioning the Piston rod.**

Bearing plate can be mounted.

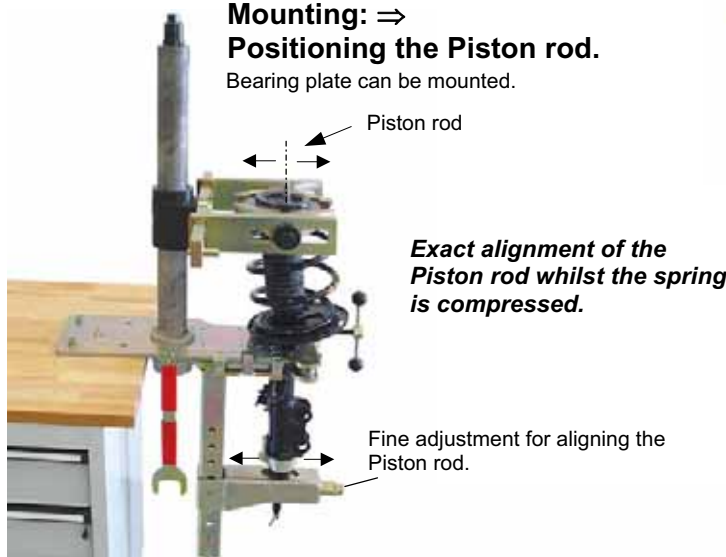

Workshop trolley  
KL-4999-100 (optional)

#### Accessories:

**KL-4999-100 - Workshop trolley**  
(without spring compressor)

Sturdy and mobile workstation. Drawers are provided with single-locking device and central closure. Solid copper beech board spray-glued, large mobile frame with robust sliding wheels with double brake.

#### Technical Data:

Weight: ..... 125 kg  
 Dimensions: ..... B 1310 x H 925 x T 600 mm  
 Worktop: ..... B 1200 x H 25 x T 600 mm  
 Drawers (1x) ..... B 1035 x H 180 mm  
 Drawers (2x) ..... B 490 x H 135 mm  
 Drawers (4x) ..... B 490 x H 180 mm  
 Castors with brakes (2x) Ø 125 mm  
 Fixed roller (2x) Ø 125 mm

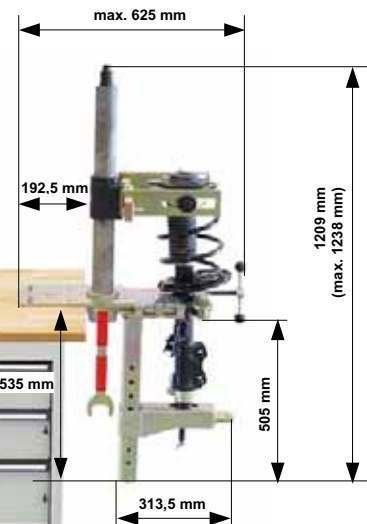

#### KL-5501 - Spring Compressor

**Technical Data:**  
(see III.)

**Weight** without trolley : 46 kg

### Our Telescopic Spring Compressors KL-9002 and KL-9001 in use.

1

⇒ Conic spring compression and decompression



⇒ Compression and removal of springs inside the vehicle.

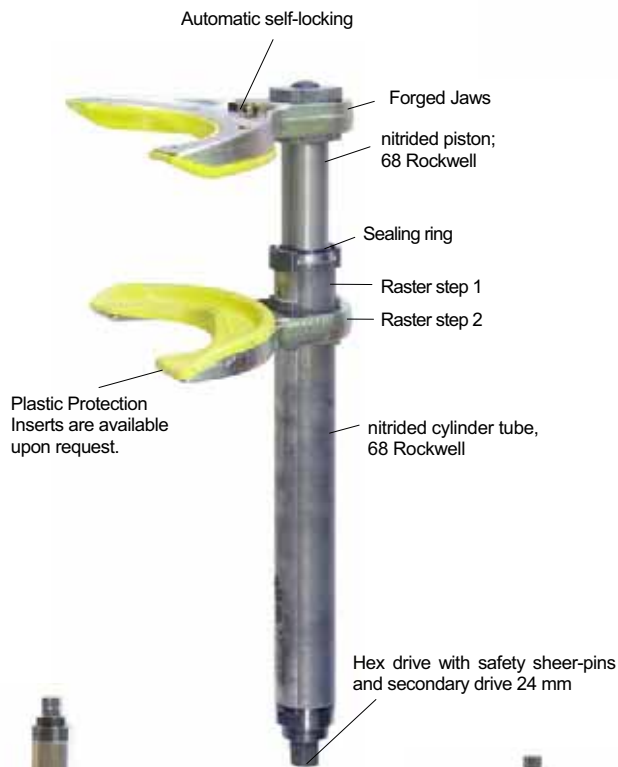
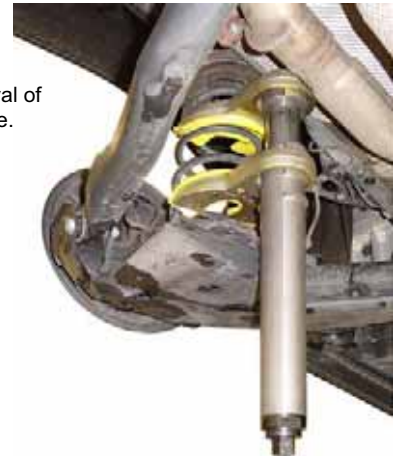

⇒ Spring and upper spring cup compression.



⇒ Spring and upper spring cup compression.



# THE RIGHT DECISION

*Spring Compressors with new Technology for the Future.*

**KL-9002 / KL-9001** (Patentiert e.g. US-Patent 5 954 314)  
Telescopic Safety Spring Compressors

✓ *Universal suitable for MacPherson-Struts or Semi-Struts*

✓ Drive rated for **1/2"-Impact Guns**

✓ **Grid system** to adjust jaw opening width (Pat.)

✓ Patented **Bayonet Locking System** for Jaw mountings with automatic self-locking

✓ **Exchangeable Plastic protective Inserts** to eliminate the risk of spring-breakages resulting from corrosion (Pat.)

✓ Fully approved by BGS after **Safety Tests**



✓ maximum Load **27 500 N**



✓ **Automatic Spindle Freewheel**

✓ Sealed Spindle system "**Maintenance-Free**" (no particles can enter)

✓ No Key bed in the Pistons  
➤ **High Load Capacity**

✓ Cylinder and Pistons nitrided (68 Rockwell) resulting in **extreme resistance to wear**

1

### KL-9002 (Pat.) with stroke 305 mm

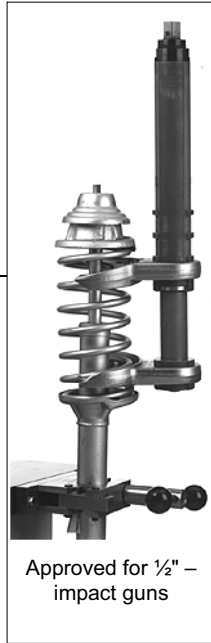

Approved for 1/2" – impact guns

### KL-9001 (Pat.) with stroke 245 mm



The **KL-9002 universal coil spring compressor** is recommended to workshops because this tool has an extended travel (stroke) of 305 mm, a maximum distance between jaws of 377 mm and a minimum distance between jaws of 40 mm. In order to repair all types of Strut suspensions, these are the characteristics required by the Spring Compressor.

### KL-9002 Telescopic Spring Compressor

Part No.	Description
<b>KL-9002</b>	<b>Telescopic Spring Compressor (with extended stroke)</b>
<i>consists of:</i>	
KL-9002-100	Compressor Cylinder
KL-9001-11	Jaws (Pair) Size 1
KL-9001-12	Jaws (Pair) Size 2

For Technical Data see page 1-09.

#### KL-9002 SP Telescopic Spring Compressor

As **KL-9002**, but with Jaws including Protective Inserts.

### KL-9001 Telescopic Spring Compressor

Part No.	Description
<b>KL-9001</b>	<b>Telescopic Spring Compressor</b>
<i>consists of:</i>	
KL-9001-100	Compressor Cylinder
KL-9001-11	Jaws (Pair) Size 1
KL-9001-12	Jaws (Pair) Size 2

For Technical Data see page 1-09.

#### KL-9001 SP Telescopic Spring Compressor

As **KL-9001**, but with Jaws including Protective Inserts.

### KL-9002 and KL-9001 Telescopic Spring Compressor

(Patented, e.g. US-Patent 5 954 314)

Suitable for vehicles with **MacPherson Struts and Semi-Struts**, in particular for 4x4 vehicles, Transporters and Vans such as Citroën Jumper; Fiat Ducato; Mercedes Vito, V-Class, M-Class, W210 4Matic; Peugeot Boxer, Break; Renault Master etc.

⇒ If required, additional jaws can be used (see pages 1-10 1-11).

Special jaws allow coil springs to be removed and replaced in wishbone suspensions provided access permits.

<b>Max. Load 27 500 N *</b>	
<b>For Spring-Ø of 70-210 mm</b>	

\* at the official 4-times Safety-Factor, the maximum safe load of both KL-9002 and KL-9001 is 27,500 N !!

#### The only Telescopic Spring Compressor on the market,

- which due to a **Raster mounting system** offers an adjustable range of jaw openings, from a minimum of **40 mm** (KL-9002 / KL-9001) to a maximum of **377 mm** (KL-9002) or **349 mm** (KL-90021). This is important when compressing very short springs (2-3 coils) and also very long springs which must be fully de-compressed to be replaced. (eg. Audi, BMW, Fiat, Ford, Lancia, Mazda, Mercedes, Renault etc.)
- which offers a patented **Bayonet Interlock System with automatic self-locking** to attach the forged jaws (no tools, bolts or locking rings required).
- whose spindle drive remains closed in case the locking pin breaks. Due to a secondary drive the spring can be decompressed and removed to install a new locking pin.
- which offers **automatic free-wheel** if the spindle reaches the end of operating travel during de-compression – so eliminating the risk of damage to the spring-compressor.
- which offers **automatic free-wheel** if the spindle reaches the end of operating travel during de-compression – so eliminating the risk of damage to the spring-compressor.
- which is suitable for all MacPherson Struts, Semi-Struts and can also be used on many wishbone suspensions as a result of the **wide assortment of jaws** available.



### KL-9002-100

Dimensions of minimum travel in Rasters 1 & 2

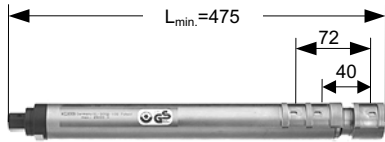

**KL-9002-100**  
Cylinder

Dimensions of maximum travel in Rasters 1 & 2

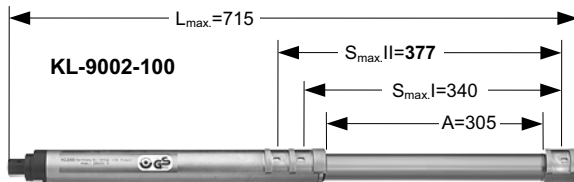

### KL-9001-100

Dimensions of maximum travel in Rasters 1, 2 & 3

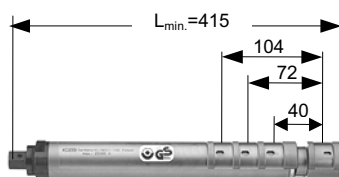

**KL-9001-100**  
Cylinder

Dimensions of maximum travel in Rasters 1, 2 & 3

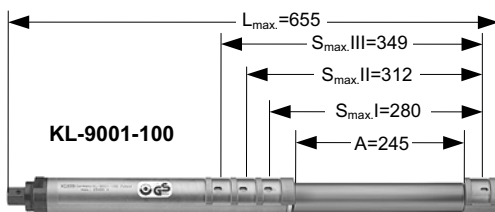

### KL-9001 and KL-9002 Technical Data

Cylinder		KL-9001-100	KL-9002-100
L <sub>min.</sub>	Overall length <sub>min.</sub>	415 mm	475 mm
L <sub>max.</sub>	Overall length <sub>max.</sub>	655 mm	715 mm
A	Working Travel (stroke)	<b>245 mm</b>	<b>305 mm</b>
SPF	Cylinder free wheel at	675 mm	735 mm
S <sub>min.I</sub>	Jaw separation <sub>min.</sub> (I) (distance between jaws)	<b>40 mm</b>	<b>40 mm</b>
S <sub>min.II</sub>	Jaw separation <sub>min.</sub> (II) (distance between jaws)	72 mm	72 mm
S <sub>min.III</sub>	Jaw separation <sub>min.</sub> (III) (distance between jaws)	104 mm	-
S <sub>max.I</sub>	Jaw separation <sub>max.</sub> (I) (distance between jaws)	280 mm	340 mm
S <sub>max.II</sub>	Jaw separation <sub>max.</sub> (II) (distance between jaws)	312 mm	<b>377 mm</b>
S <sub>max.III</sub>	Jaw separation <sub>max.</sub> (III) (distance between jaws)	<b>349 mm</b>	-
	Working load <sub>max.</sub>	25 000 N	25 000 N
	Working load <sub>max.</sub> (at 4-times safety factor)	27 500 N	27 500 N
	Breaking load	110 000 N	110 000 N
	spindle drive	hex 24 mm	hex 24 mm
	spindle drive torque <sub>max.</sub> with 1/2"-hand ratchet	180 Nm	180 Nm
	Cylinder weight	6,0 kg	6,9 kg
	Cylinder weight with Jaws size. 1 and 2	12,5 kg	13,4 kg



#### Note:

- Maximum load values refer to the clamping cylinder together with the pair of jaws KL-9001-11.
- Operating the spindle with mechanical tools ensure that the torque limit of 180 Nm is not exceeded.

#### Example:

To compress a spring which is coil bound at 15,000 N (e.g. Mercedes W126) a torque of only approx. 58 Nm is required!

#### Examples of coil-bound forces:

VW Polo AO3....approx. 6 000 N	VW Golf A4..... approx. 7 000 N
VW Passat B5 ..approx. 8 000 N	Audi A4 6 cyl..... approx. 9 000 N
Mercedes Vito ..approx. 14 200 N	Chrysler Voyager. approx. 14 000 N
Peugeot Boxer approx. 15 000 N	Fiat Ducato ..... approx. 15 000 N
MB M Class approx. 18 000 N	BMW X5 .....approx. 18 000 N

# 1

**Pairs of Jaws**

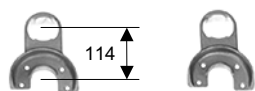
size 0  **KL-9001-10**  
Pair of Jaws without Protective Inserts  
**KL-9001-10 SP**  
Pair of Jaws with Protective Inserts

size 1  **KL-9001-11**  
Pair of Jaws without Protective Inserts  
**KL-9001-11 SP**  
Pair of Jaws with Protective Inserts

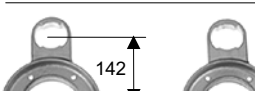
size 2  **KL-9001-12**  
Pair of Jaws without Protective Inserts  
**KL-9001-12 SP**  
Pair of Jaws with Protective Inserts

**Pairs of Jaws**

size 3  **KL-9001-13**  
Pair of Jaws without Protective Inserts  
**KL-9001-13 SP**  
Pair of Jaws with Protective Inserts

size 4  **KL-9001-14**  
Pair of Jaws without Protective Inserts

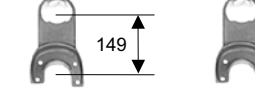
size 5  **KL-9001-15**  
Pair of Jaws without Protective Inserts

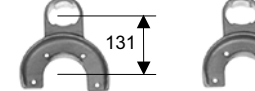
size 1 B  **KL-9001-33**  
Pair of Jaws without Protective Inserts  
**KL-9001-33 SP**  
Pair of Jaws with Protective Inserts

**Pairs of Jaws with extended mountings to accommodate conical springs and inaccessible springs.**

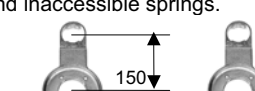
size 0  **KL-9001-16**  
Pair of Jaws without Protective Inserts  
**KL-9001-16 SP**  
Pair of Jaws with Protective Inserts

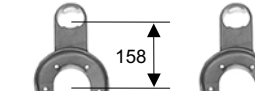
size 1  **KL-9001-17**  
Pair of Jaws without Protective Inserts  
**KL-9001-17 SP**  
Pair of Jaws with Protective Inserts

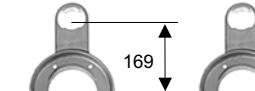
size 2  **KL-9001-18**  
Pair of Jaws without Protective Inserts  
**KL-9001-18 SP**  
Pair of Jaws with Protective Inserts

size 1  **KL-9001-32 SP**  
Pair of Jaws with Protective Inserts  
**(German Utility Model)**

**KL-9001-33 SP**

**Porsche, VW**



### Pairs of Jaws with a closed attachment ring (Pat.)

#### Special Pair of Jaws

Part No.	For spring Ø	Weight	For Vehicles
KL-9001-10 (size 0)	70-125 mm	Pair 2.5 kg	Audi, Chrysler, Daewoo, Daihatsu, Fiat, Ford, Honda, Kia, Lada, Lancia, Mazda, Mercedes, Mitsubishi, Nissan, Opel/Vauxhall, Porsche, Rover, Saab, Seat, Škoda, Subaru, Suzuki, Toyota, Volvo, VW etc.
	Accessory		

#### Standard Pairs of Jaws

Part No.	For spring Ø	Weight	For Vehicles
KL-9001-11 (size 1)	100-163 mm	Pair 3.1 kg	Alfa Romeo, Audi, BMW, Chrysler, Citroën, Daewoo, Daihatsu, Fiat, Ford, Honda, Hyundai, Kia, Lada, Lancia, Mazda, Mercedes, Mitsubishi, Nissan, Opel/Vauxhall, Peugeot, Porsche, Renault, Rover, Saab, Seat, Škoda, Ssang Yong, Subaru, Suzuki, Toyota, Volvo, VW etc.
	Standard		
KL-9001-12 (size 2)	135-175 mm	Pair 3.3 kg	Alfa Romeo, BMW, Chrysler, Citroën, Fiat, Ford, Honda, Hyundai, Lancia, Mazda, Mercedes, Mitsubishi, Nissan, Opel/Vauxhall, Peugeot, Renault, Rover, Saab, Seat, Subaru, Suzuki, Toyota, Volvo, VW etc.

#### Special Pairs of Jaws

Part No.	For spring Ø	Weight	Applications
KL-9001-13 (size 3)	165-210 mm	Pair 4,3 kg	Alfa Romeo, Audi, BMW, Chrysler, Citroën, Fiat, Ford, Kia, Lancia, Mazda, Mitsubishi, Nissan, Peugeot, Renault, Rover, Subaru, Toyota, Volvo etc.
	Accessory		
KL-9001-14 (size 4)	Accessory	Pair 3,0 kg	Citroën C 15 Rear axle, Peugeot 305 Break Rear axle
KL-9001-15 (size 5)	70-116 mm	Pair 3,0 kg	Mercedes W210 4Matic, Alfa Romeo, Mazda, Mercedes, Mitsubishi, Nissan, Chrysler, Nissan, VW Lupo rear axle, etc.
KL-9001-33 (size 1 B)	100-163 mm	Pair 3,2 kg	Porsche Cayenne, VW Touareg

### Pairs of Jaws with extended mountings

#### Required for conical and inaccessible springs.

Part No.	For spring Ø	Weight	Applications
KL-9001-16 (size 0)	70-125 mm	Pair 3,0 kg	VW e.g. Golf V rear axle, Volvo
	Accessory		
KL-9001-17 (size 1)	100-163 mm	Pair 3,7 kg	Nissan Pathfinder, Seat Arosa, VW Lupo, Mercedes etc.
KL-9001-18 (size 2)	135-175 mm	Pair 3,7 kg	Audi, BMW, Honda, Renault Toyota, Nissan Mercedes W203, Mitsubishi, Peugeot etc.
KL-9001-32SP (size 1)	Accessory	Pair 3,7 kg	Audi A8 (armoured) rear axle

### KL-9001-33 SP Pair of Jaws Size 1B with Protective Inserts

#### Suitable for Porsche Cyenne, VW Touareg

#### Removal and replacement of front springs.

Part No.	Description	For spring Ø	Weight	Applications
KL-9001-33	Pair of Jaws Size 1B	100-163 mm	3,2 kg	Porsche Cayenne, VW Touareg
KL-9001-25	Pair of protective inserts		0,2 kg	

⚠ The 4 small holes in the jaws serve to locate the protective inserts.

#### Note:

Vehicle Application List see page 1-24 and 1-25

### KL-9001-1920

Peugeot  
206

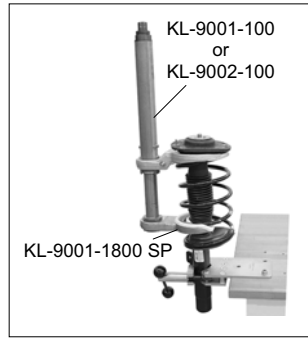

### KL-9001-1920 Jaw size 6

Suitable for Peugeot 206.

If this jaw, which is a new development, is used with spring compressor **KL-9001-100** or **KL-9002-100** and jaw **KL-9001-1800 SP**, the front suspension strut spring can be removed in just a few minutes.

**Note:** Compress the spring together with the upper spring plate and increasing spring compressor until there is no pressure on the support bearing.

Part No.	For Spring-Ø	Weight	Suitable for:
KL-9001-1920 (size 6)	70-125 mm Accessory	1,9 kg	Peugeot 206 front axle

### KL-9001-91

BMW



### KL-9001-91 Jaw Set for BMW

**Applications: BMW E46 (3 Series from '98), E39 (5 Series from '95)**

Removal and replacement of front springs.

Part-No.	Description	Jaws-Ø	Weight	Applications
KL-9001-1900	Jaw ring	165 mm	2,8 kg	BMW E46 (3 Series) BMW E39 (5 Series)
KL-9001-1910	Adaptor ring for KL-9001-1900		0,1 kg	BMW E46 (3 Series) BMW E39 (5 Series)
KL-9001-1310	Jaw size 3	165 - 210 mm	1,7 kg	universal
KL-9001-2301	Protective insert size 3 for KL-9001-1310		0,15 kg	universal

### KL-9001-92

Mercedes



### KL-9001-92 Jaw Set for Mercedes

**Application: Mercedes C-Class (W203), CLK (W209)**

Removal and replacement of front springs.

Part-No.	Description	Jaws-Ø	Weight	Applications
KL-9001-3100	Jaw ring	196 mm	3,0 kg	Mercedes C-class (W203) Mercedes CLK (W209)
KL-9001-3110	Adaptor ring for KL-9001-3100		0,7 kg	Mercedes C-class (W203) Mercedes CLK (W209)
KL-9001-1800	Jaw size 2	135 - 175 mm	1,8 kg	universal
KL-9001-2201	Protective insert size 2		0,1 kg	universal

### Protective Inserts (Pat.)

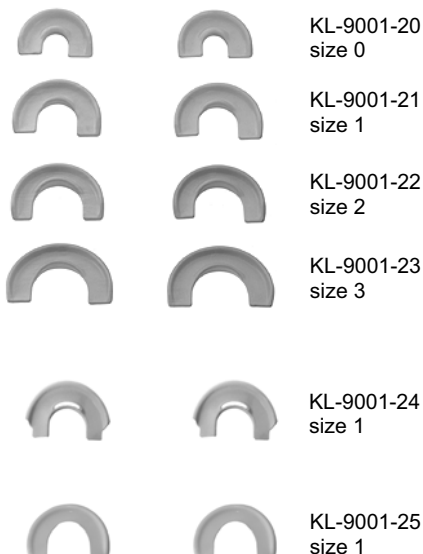

### Protective Inserts (Pat.)

Incl. 8 plastic rivets **KL-9001-2002** per pair of inserts.

Protective Insert Pair		For pair of Jaws	
Part No.	size	Part No.	size
KL-9001-20	size 0	KL-9001-10	size 0
KL-9001-21	size 1	KL-9001-11	size 1
KL-9001-22	size 2	KL-9001-12	size 2
KL-9001-23	size 3	KL-9001-13	size 3
KL-9001-24	size 1	KL-9001-32	size 1
KL-9001-25	size 1	KL-9001-33	size 1

**Note:**

Vehicle Application List see page 1-24 and 1-25.

1

### Universal Spring Compressor KL-0015 in use!!!

⇒ Compression and removal of springs inside the vehicle.



⇒ Spring and upper spring cup compression.



⇒ Spring and upper spring cup compression.



⇒ Conic spring compression and decompression with KL-1590-1



⇒ Shock absorber replacement and installation of the upper spring cup with KL-0255 and KL-0255-10 (see pages 1-26 - 1-27)



### KL-0015 Universal Spring Compressor (Patented)

(e.g. US-Patent 4 976 416)

This legendary Spring Compressor remains after more than 20 years still the best on the market. No other unit has been sold so successfully in the past, and so widely used in the repair of MacPherson Struts.

#### The particular advantages are:

- An ever-increasing range of Jaws are available to respond to the **ever-differing applications** required by the latest vehicle types (Pat.)
- Exchangeable Protective Plastic Jaw Inserts** are available to prevent damage to the coating of the coil-springs (German Utility Model)
- Conical** or **Barrel** springs may be easily and safely compressed using the Adaptor **KL-1590-1**
- Fully approved by BGS after **Safety Tests**
- Universal for** MacPherson- Struts and Semi-Struts
- Extended working travel of 300mm** allows long coil-springs to be removed and replaced
- Patented** Self-locking of the moving Jaw-holder under load of the compressed spring is not borne by the Spindle (Pat.)
- Minimum Distance between Jaws of 50mm** Important for very short springs
- Spindle Drive** fully rated for use with **Air Impact Gun**
- Case hardened cylinder body**



Max. Load 17 500 N

For Coil-Springs with Ø 70-240 mm



Leading Car manufacturers have chosen the **KL-0015 Spring Compressor**.

**VW- Audi, BMW, Ford and Opel-Vauxhall** prescribe the use of **Protective Jaw-inserts** for compressing coil-springs in order to prevent the risk of spring breakages resulting from corrosion arising from damage to the outer coating.

1

### KL-0015



### KL-0015 Universal Spring Compressor

Universal Spring Compressor with extended stroke.

Universal suitable for struts and semi-struts.

Supplied with Jaws size 1N and 2N.

Maximum Load: ..... 17 500 N. Working travel:..... 300mm

#### Advantage:

- Patented self-locking feature.
- Improved load absorption onto the hardened tool body.
- Approved by BGS German Workers Safety Insurance.
- Suitable for use with very long springs.

The ideal tool for the workshop.

### KL-0015 SP Universal Spring Compressor

As KL-0015, but incl. Pair of Jaws with Protective Inserts.

### KL-0013



### KL-0013 Universal Spring Compressor

Suitable for struts and Semi-struts.

Supplied with Jaws size 1N and 2N.

Maximum Load: ..... 17 500 N. Working travel :...240 mm

#### Advantage:

- Patented self-locking feature.
- Improved load absorption onto the hardened tool body.
- Approved by BGS German Workers Safety Insurance.

### KL-0013 SP Universal Spring Compressor

As KL-0013, but incl. Pair of Jaws with Protective Inserts.

### KL-2000



### KL-2000 Universal Spring Compressor

Suitable for Struts and Semi-Struts.

Supplied with Jaws size 1N and 2N.

Maximum Load: ..... 8 500 N. Working travel :...245 mm

#### Advantage:

- Loading contained within the tool body.
- Improved load absorption onto the tool body.
- Tool body case hardened.
- Approved by BGS German Workers Safety Insurance.

### KL-2000 SP Universal Spring Compressor

As KL-2000, but incl. Pair of Jaws with Protective Inserts.

### KL-0015-100

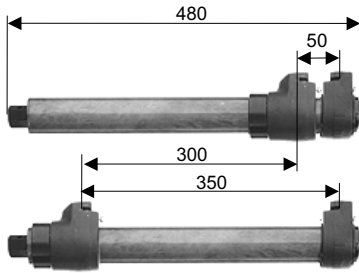

### KL-0013-100

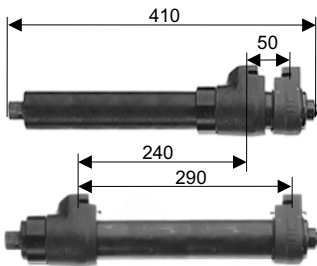

### KL-2000-100

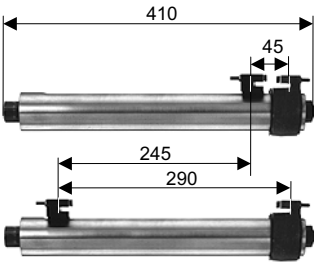

### Protective Inserts

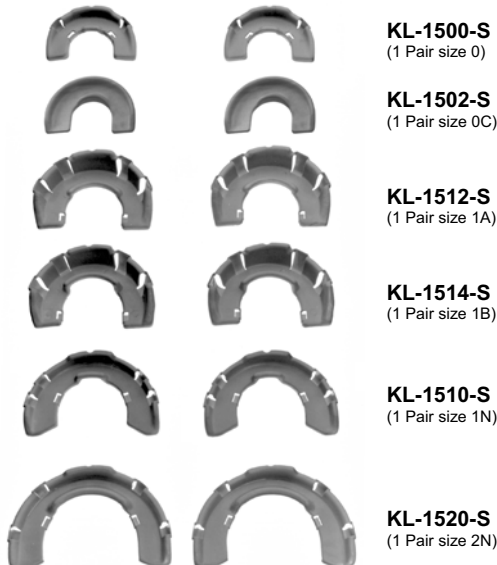

### KL-0015-100 Technical Data

Part No.	KL-0015-100
Compression length	50-350 mm
Working travel	300 mm
Overall Tool length (L)	480 mm
Drive	Ratchet or impact wrench drive
Max. load	17 500 N
Breaking point	80 000 N
Weight	6,3 kg

#### Note:

On account of the long working travel, only this Compressor Cylinder should be used in the workshop.

### KL-0013-100 Technical Data

Part No.	KL-0013-100
Compression length	50-290 mm
Working travel	240 mm
Overall Tool length (L)	410 mm
Drive	Ratchet or impact wrench drive
Max. load	17 500 N
Breaking point	70 000 N
Weight	5,6 kg

### KL-2000-100 Technical Data

Part No.	KL-2000-100
Compression length	45-290 mm
Working travel	245 mm
Overall Tool length (L)	410 mm
Drive	Ratchet or impact wrench drive
Max. load	8 500 N
Breaking point	32 000 N
Weight	4,8 kg

### Protective Inserts

Protective Insert pair	For Jaws	Pair of Jaws complete with protective inserts
Part-No.	Part-No.	Part-No.
KL-1500-S	KL-1500	KL-1500-SP
KL-1502-S	KL-1502	KL-1502-SP
KL-1512-S	KL-1512	KL-1512-SP
KL-1514-S	KL-1514	KL-1514-SP
KL-1510-S	KL-1510	KL-1510-SP
KL-1520-S	KL-1520	KL-1520-SP

Protective insert (pcs.)	For Jaws	Pair of jaws complete with protective inserts
Part-No.	Part-No.	Part-No.
KL-1521-S	KL-1525	KL-1525-SP

# 1

### Special Jaws

Gr. 0



**KL-1500**  
Pair of Jaws without Protective Inserts  
**KL-1500 SP**  
Pair of Jaws with Protective Inserts

size 0C



**KL-1502**  
Pair of Jaws without Protective Inserts  
**KL-1502 SP**  
Pair of Jaws with Protective Inserts

size 1A



**KL-1512**  
Pair of Jaws without Protective Inserts  
**KL-1512 SP**  
Pair of Jaws with Protective Inserts

size 1B



**KL-1514**  
Pair of Jaws without Protective Inserts  
**KL-1514 SP**  
Pair of Jaws with Protective Inserts

### Standard Jaws

size 1N  
(Pat.)



**KL-1510**  
Pair of Jaws without Protective Inserts  
**KL-1510 SP**  
Pair of Jaws with Protective Inserts

size 2N  
(Pat.)



**KL-1520**  
Pair of Jaws without Protective Inserts  
**KL-1520 SP**  
Pair of Jaws with Protective Inserts

### Special Jaws

size 3N  
(Pat.)



**KL-1530**  
Pair of Jaws without Protective Inserts

size 5



**KL-1550**  
Pair of Jaws without Protective Inserts

size 2B  
**KL-1525**



size 6  
**KL-1561**

**KL-1581-R**



**KL-1571**



### Note:

**VW Golf V** ⇒ required jaws  
Front axle - KL-1510 / Rear axle - KL-1502 + KL-1590-2

**Peugeot 206** ⇒ required jaws  
Front axle - KL-1561 + KL-1511 SP

### Pair of Jaws

The following Jaws can be used for the Universal Spring Compressors **KL-2000**, **KL-0013**, **KL-0014** and **KL-0015**.

### Special Pair of Jaws

Part-No.	For Spring-Ø	Weight	Application
<b>KL-1500 (size 0)</b>	70-110 mm	Pair 1,1 kg	Audi, BMW, Daewoo, Daihatsu, Fiat, Ford, Honda, Kia, Lada, Mazda, Mercedes A Class, Mitsubishi, Nissan, Opel/Vauxhall, Rover, Seat, Škoda, Subaru, Suzuki, Toyota, Volvo, VW, Alfa Romeo, Chrysler etc.
<b>KL-1502 (size 0C)</b>	70-110 mm	Pair 1,1 kg	Volvo, Golf V
<b>KL-1512 (size 1A)</b>	80-150 mm	Pair 1,9 kg	Audi A4 front-axle, Audi A8 rear axle, Porsche, Saab 90/900, Chrysler, Opel/Vauxhall etc.
<b>KL-1514 (size 1B)</b>	85-150 mm	Pair 2,0 kg	Audi A8 front axle

### Standard Pair of Jaws

Part-No.	For Spring-Ø	Weight	Application
<b>KL-1510 (size 1N)</b>	80-165 mm	Pair 1,3 kg	Alfa Romeo, Audi, BMW, Chrysler, Citroën, Daewoo, Daihatsu, Fiat, Ford, Honda, Hyundai, Kia, Lada, Lancia, Mazda, Mercedes A Class, Mitsubishi, Nissan, Opel/Vauxhall, Peugeot, Porsche, Renault, Rover, Saab, Seat, Škoda, Ssang Yong, Subaru, Suzuki, Toyota, Volvo, VW etc.
<b>KL-1520 (size 2N)</b>	155-195 mm	Pair 1,9 kg	Alfa Romeo, Audi, BMW, Chrysler, Citroën, Fiat, Ford, Honda, Hyundai, Kia, Lancia, Mazda, Mitsubishi, Nissan, Opel/Vauxhall, Peugeot, Renault, Rover, Saab, Seat, Subaru, Suzuki, Toyota, Volvo, VW, Porsche etc.

### Special Pair of Jaws

Part-No.	For Spring-Ø	Weight	Application
<b>KL-1530 (size 3N)</b>	180-240 mm	Pair 3,0 kg	BMW 7 series (E38), Chrysler, Renault GM-X and C, Lancia (Gamma)
<b>KL-1550 (size 5)</b>	Special	Pair 2,3 kg	Citroën C 15 rear-axle, Peugeot 305 Break rear-axle

### Special Jaws

Part-No.	For Spring-Ø	Weight	Application
<b>KL-1525 (size 2B)</b>	155-195 mm (larger rise)	1 piece 0,9 kg	BMW 3 series (E46) BMW 5 series (E39)
<b>KL-1561 (size 6)</b>	Special Recess: 110 mm  Inner-Ø: 180 mm	1 piece 1,3 kg	Ford Probe, Mazda 323, 626, MX6, Mitsubishi-Galant with electronically-pneumatically controlled Strut
<b>KL-1571</b>	Special Recess: 139 mm  Inner-Ø: 165 mm	1 piece 2,3 kg	BMW 8 series E31 BMW 3 series E46 (from '98) BMW 5 series E39 (from '95)
<b>KL-1581-R</b>	Special Recess: 162 mm  Inner-Ø: 238 mm	1 piece 2,5 kg	Renault Laguna and Safrane, Lancia Gamma in conjunction with Jaw size 3 Hyundai

### Note:

Vehicle Application List see page 1-24 and 1-25.



### KL-1516-SP

size 1C



### KL-1540 (German Utility Model)



### Special Jaws for BMW

German Utility Model

KL-1525



KL-1571



KL-1521-S



KL-1575



### KL-1570-1

German Utility Model

KL-1525



KL-1521-S



KL-1575



### KL-1590-1

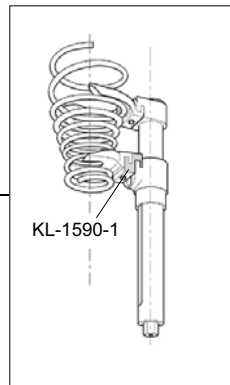

### KL-1590-2

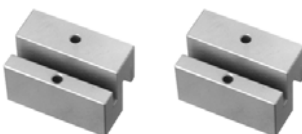

**Note:**

Vehicle Application List see page 1-24 and 1-25.

### KL-1516-SP Jaws (Pair) size 1C complete with Protective Inserts

Suitable for Audi A4 rear-axle from 2001.

This newly-developed pair of Jaws used in conjunction with Spring Compressor cylinder **KL-0015-100** allows the removal and replacement of the rear coil-springs in just a few minutes, without the need to dismantle the wish-bone or to drop the rear sub-frame. This method removes the need to perform a wheel-alignment after rear coil-springs have been replaced.

Jaws-Ø:..... 80-150 mm

Weight:..... 1.850 g

### KL-1540 Jaw Set Size 4 (4 Pcs.) (German Utility Model)

Application: VW Golf, Bora, 4x4 Off Roaders (4 Motion)

**Advantage:**

- Eliminates removal of the rear axle.
- Eliminates an additional re-alignment of rear axle geometry.
- Eliminates dismounting shock-absorber and Drive-Shaft.

These specially-formed Jaws are essential to remove and replace rear springs.

Part-No.	Description
<b>KL-1540</b>	<b>Jaw Set Size 4</b>
<i>consists of :</i>	
KL-1541	Jaw Size 4 left lower
KL-1543	Jaw Size 4 left upper
KL-1545	Jaw Size 4 right lower
KL-1547	Jaw Size 4 right upper

### Special Jaws for BMW

Jaw **KL-1525** and the associated protection insert **KL-1521-S** allows compression of the front springs on **BMW E46 (3-series from '98), E39 (5-series from '95)** in conjunction with the Ring Jaw **KL-1571** and with the corresponding adaptor-ring **KL-1575**.

- **KL-1525 Jaw size 2B** The Jaw **KL-1525** provides a steeper helix (rise per 360° rotation) than the normal Jaw size 2 (KL-1521).
- **KL-1521-S Protective Insert size 2N** for use with Jaw KL-1525.
- **KL-1571 Ring-Jaw** suitable for BMW E31 (8-series) in conjunction with Jaw size 2N, and for E46 (3 series from '98), E39 (5 series from '95) in conjunction with Adaptor-Ring **KL-1575**.  
opening-Ø: ..... 139 mm Inner-Ø: .... 165 mm
- **KL-1575 Insert-Ring for Ring-Jaw KL-1571** suitable for BMW E46 (3 series from '98), E39 (5 series from '95) front coil springs.  
opening-Ø: ..... 139 mm Inner-Ø: .... 160 mm

### KL-1570-1 Jaw Set BMW

contents:

Part-No.	Jaws-Ø	Description
KL-1525	155-195 mm	Jaw Size 2B
KL-1521-S	155-195 mm	Protective insert Size 2N
KL-1575	160 mm	Insert-Ring for KL-1571

### KL-1590-1 Adaptor for Conical springs

Application Alfa Romeo, Chrysler, Nissan, Seat Arosa, VW Lupo etc. Allows safe compression of conical springs with **KL-0013, KL-0015** and **KL-2000** Spring Compressors.

### KL-1590-2 Adaptor-Set

For extending the jaws e.g. for compressing the **VW Lupo** Rear Springs or Barrel Springs. (Consists of 2x KL-1590-1).

1

### KL-0025-1 / KL-0021

Mercedes

3 Point Interlock Safety Profile

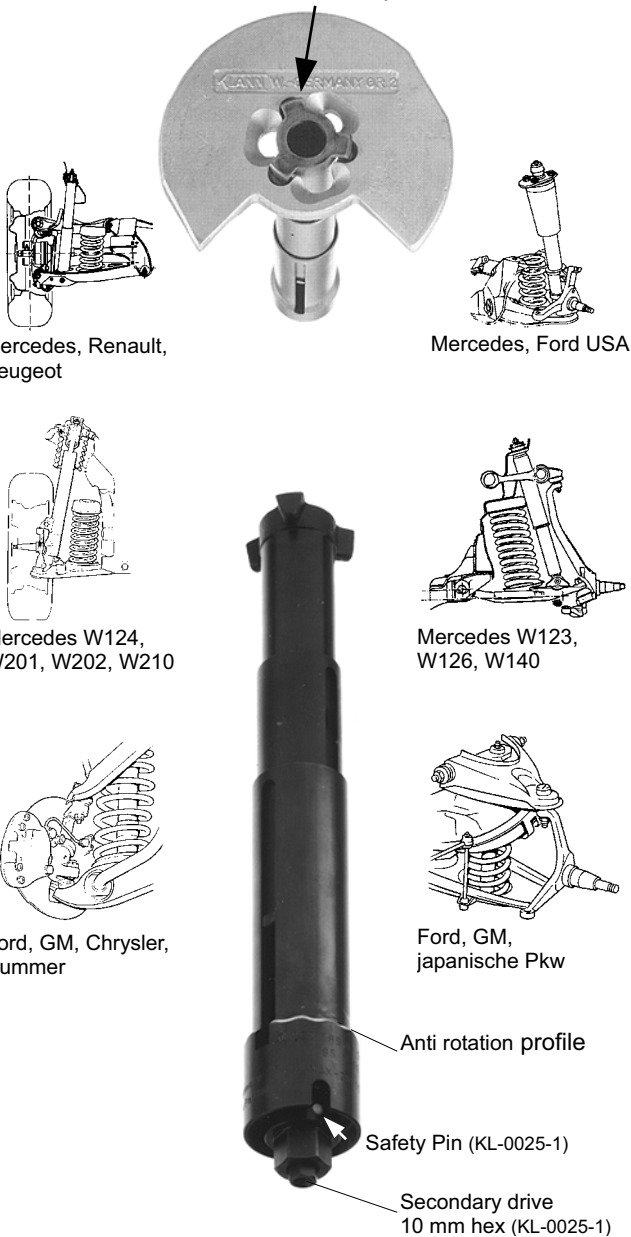

Mercedes, Renault, Peugeot

Mercedes, Ford USA

Mercedes W124, W201, W202, W210

Mercedes W123, W126, W140

Ford, GM, Chrysler, Hummer

Ford, GM, japanische Pkw

Anti rotation profile

Safety Pin (KL-0025-1)

Secondary drive 10 mm hex (KL-0025-1)

### KL-0025-1 K / KL-0021 K

Mercedes



### KL-0025-1 Universal Spring Compressor

(Pat.) (e.g. US-Patent 4 809 951)

As KL-0025-1 K but without plastic case.

For wishbone and multi-link independent suspensions supplied with pairs of pressure plates size 1 and 2.

Fits to Mercedes W116, W123, W124, W126, W129, W140, W170, W171, W201, W202, W208, W210 and W211 front and rear axle.

Ford, GM, Chrysler, VW-type 2 and LT, Fiat, Hummer, Mazda, Toyota, Nissan, Mitsubishi, Renault, Peugeot, Volvo, etc.

This universal telescopic safety spring compressor with 3-point interlock, anti rotation profile and a new spindle overload protection is unique in its art (German Utility Model).

It offers the possibility of a quick and easy removal and installation of coil springs at wishbone and multi-link independent suspensions, without dismantling the axle (exceptions possible). Thus giving simultaneously a high level of safety and a job time saving of between 1 to 2 hours.

**Note:**

If the spindle is overloaded, the safety pin in the main drive breaks, but the drive mechanism remains active and the compressed spring can be released by the secondary drive.

Accidents due to spindle overload are eliminated.

**Advantage:**

- The patented 3-point interlock allows compression of the spring only when the piston is correctly locked into the pressure plate. Accidents due to faulty interlock are eliminated.
- Automated free-wheel at maximum of working travel means that any residual spring pressure cannot be released.
- All important components, such as pressure plates, piston, tube and housing are fully interlocked with each other. This safety feature eliminates the possibility of the compressed spring unwinding itself.
- All critical components are drop-forged heat treated.
- This spring compressor has been tested and approved by the German Workers Safety Insurance (BGS) and by Mercedes.
- As a result of the telescopic design of the compressor which reduces the length of the tool as the spring is compressed, coil springs can very often be changed without the need to dismantle the suspension. Time saving of between 30 minutes and 2 hours per spring can be achieved.
- Universal use of the tool due to an extended variety of pressure plates.

### KL-0025-1 K Spring Compressor with case

(Pat.)

As KL-0025-1 but with Plastic Case.

**Specification:**

Part-No.	Description
KL-0025-1 K	Spring Compressor with Case
<i>consists of:</i>	
KL-0025-100	Cylinder with Overload Protection System for the Spindle
KL-0025-11	Pressure Plates Size 1
KL-0025-12	Pressure Plates Size 2
KL-0025-1090	Plastic Case

For Technical Data see page 1-20.

### KL-0021 K Spring Compressor with case

(Pat.)

As KL-0025-1 K but without spindle overload protection.

**Specification:**

Part-No.	Description
KL-0021 K	Spring Compressor with Case
<i>consists of:</i>	
KL-0021-100	Cylinder
KL-0025-11	Pair of Pressure Plates Size 1
KL-0025-12	Pair of Pressure Plates Size 2
KL-0025-1090	Plastic Case

For Technical Data see page 1-20.

### KL-0025-1

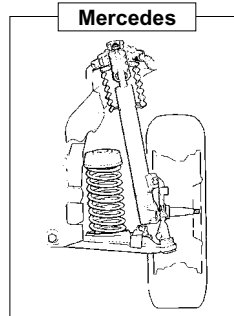
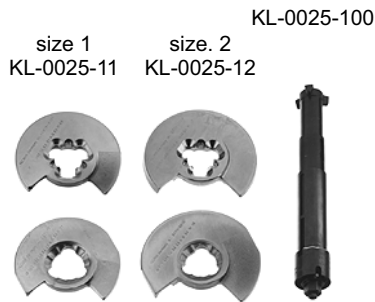

### KL-0025-1 Spring Compressor (Pat.)

(e.g. US-Patent 4 809 951)

Developed to bring the highest possible safety to the job of compressing springs in wishbone axles.

Applications: **Mercedes** W116, W123, W124, W126, W129, W140, W170, W171, W201, W202, W208, W210, W211 front and rear axles.

Also applicable for: **Ford, GM, Chrysler, VW-Audi, Fiat, Mazda, Toyota, Nissan, Mitsubishi, Renault, Peugeot, Volvo** etc.

#### Advantage:

- Autom. 3-Point Safety Interlock
- Automatic free-wheel at end of stroke
- Anti rotation profile
- Spindle overload protection

Maximum Load: 26 000 N.

Technical Data: see page 1-20.

### KL-0021

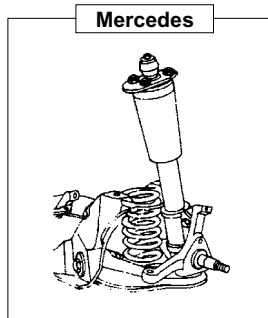
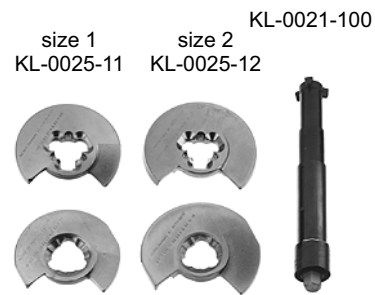

### KL-0021 Spring Compressor (Pat.)

(e.g. US-Patent 4 809 951)

For **Chrysler, Mercedes** W116, W123, W124, W126, W129, W140, W170, W171, W201, W202, W208, W210, W211 and W124 4-Matic\* front and rear axle.

Consists of: **KL-0021-100, KL-0025-11 and KL-0025-12.**

#### Advantage:

- Automatic 3-Point Safety Interlock.
- Automatic Freewheel at end of stroke.
- Anti rotation profile.

\* KL-0021-5: Pressure Plates for Mercedes W124 4-Matic (on request).

Maximum Load: 26 000 N.

Technical Data: see page 1-20.

### KL-0025-2

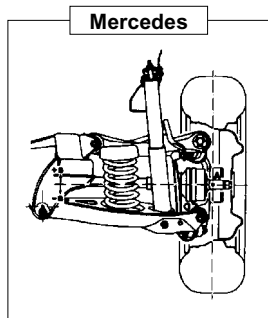
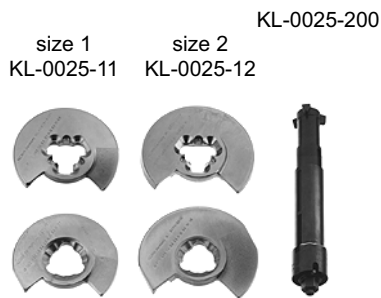

### KL-0025-2 Spring Compressor (Pat.)

(Pat.)

As **KL-0025-1**, but **short** version for rear-axes.

It allows the removal of rear axle springs in very limited room conditions without having to lower the rear axle support.

Suitable for **Mercedes** W107, W114, W115, W116, W123, W124, W126, W129, W140, W170, W171, W201, W202, W210 and W211 rear axle springs.

**Note: BMW E87** (1 series) and **E90** (3 series) rear axle springs require that the compressor cylinder **KL-0025-200** is provided with the **KL-0025-16** pressure plates.

Consists of: **KL-0025-200, KL-0025-11 and KL-0025-12**

#### Advantage:

- Autom. 3-Point Safety Interlock
- Automatic free-wheel at end of stroke
- Anti rotation profile
- Spindle overload protection

Maximum Load: 26 000 N.

Technical Data: see page 1-20.

### KL-0024

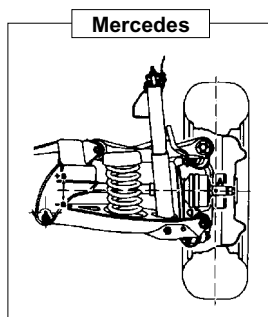
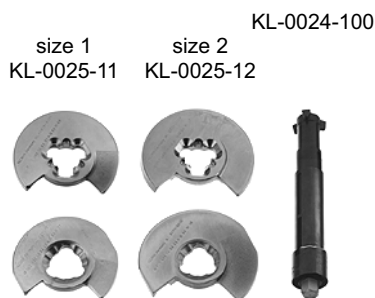

### KL-0024 Spring Compressor (Pat.)

(Pat.)

As **KL-0021**, but **short** version for rear-axes.

It allows the removal of rear axle springs in very limited room conditions without having to lower the rear axle support.

For **Chrysler, Mercedes** W107, W114, W115, W116, W123, W124, W126, W129, W140, W170, W201, W202, W208, W210, W211.

Consists of: **KL-0024-100, KL-0025-11 and KL-0025-12.**

#### Advantage:

- Automatic 3-Point Safety Interlock.
- Automatic free-wheel at end of stroke.
- Anti rotation profile.

Maximum Load: 26 000 N.

Technical Data: see page 1-20.

1

### Compressor Cyl. with Protection System for the Spindle.

**KL-0025-100**  
Front Axle



**KL-0025-200**  
Rear Axle



### Compressor Cyl. without Protection System for the Spindle.

**KL-0021-100**  
Front Axle



**KL-0024-100**  
Rear Axle



### Technical Data for Compressor Cylinders

#### KL-0025-100 Compressor Cylinder with Protection System for the Spindle

**Description:** (Front Axle)

- Telescopic construction with 3-point safety interlock
- Automatic freewheel at the end of stroke
- Anti rotation profile
- Overload protection

**Compression range:** ..... 110-317 mm  
**Working travel:** ..... 207 mm  
**Overall Tool length (L):** ..... 263 mm  
**Drive:** ..... (6-point) hex 19 mm  
**Max. load:** ..... 26 000 N  
**Breaking point:** ..... 120 000 N  
**Weight:** ..... 1,5 kg

#### KL-0025-200 Compressor Cylinder with Protection System for the Spindle

**Description:** (Rear Axle)

- Telescopic construction with 3-point safety interlock
- Automatic freewheel at the end of stroke
- Anti rotation profile
- Overload protection

**Compression range:** ..... 110-287 mm  
**Working travel:** ..... 177 mm  
**Overall Tool length (L):** ..... 233 mm  
**Drive:** ..... (6-point) hex 19 mm  
**Max. load:** ..... 26 000 N  
**Breaking point:** ..... 120 000 N  
**Weight:** ..... 1,3 kg

#### KL-0021-100 Compressor Cylinder without Protection System for the Spindle

**Description:** (Front Axle)

- Telescopic construction with 3-point safety interlock
- Automatic freewheel at the end of stroke
- Anti rotation profile

**Compression range:** ..... 110-317 mm  
**Working travel:** ..... 207 mm  
**Overall Tool length (L):** ..... 262,5 mm  
**Drive:** ..... (6-point) hex 19 mm  
**Max. load:** ..... 26 000 N  
**Breaking point:** ..... 120 000 N  
**Weight:** ..... 1,5 kg

#### KL-0024-100 Compressor Cylinder without Protection System for the Spindle

**Description:** (Rear Axle)

- Telescopic construction with 3-point safety interlock
- Automatic freewheel at the end of stroke
- Anti rotation profile

**Compression range:** ..... 110-287 mm  
**Working travel:** ..... 177 mm  
**Overall Tool length (L):** ..... 232,5 mm  
**Drive:** ..... (6-point) hex 19 mm  
**Max. load:** ..... 26 000 N  
**Breaking point:** ..... 120 000 N  
**Weight:** ..... 1,3 kg

### Special Pressure Plates with eccentric receiving bore

size 0

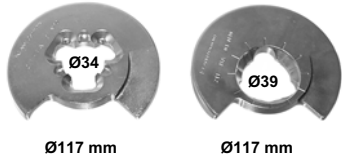

KL-0025-16

### Special Pressure Plates

size 1.5

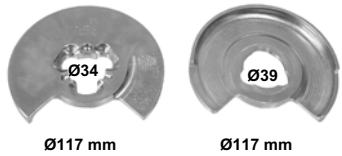

KL-0025-17

### Standard Pressure Plates

size 1

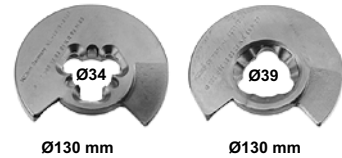

KL-0025-11

size 2

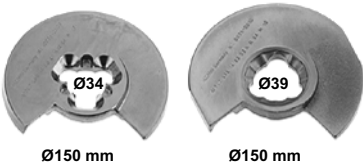

KL-0025-12

### Special Pressure Plates

size 3

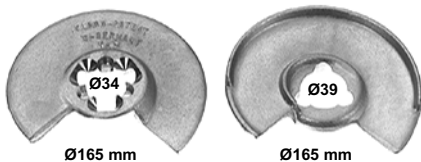

KL-0025-13

size 4

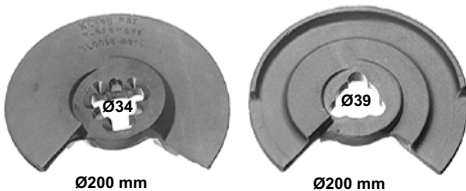

KL-0025-14

size 5

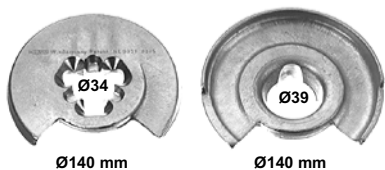

KL-0025-5

**Note:** Spring application list see page 1-24 and 1-25.

### Pair of Pressure Plates

Corrugated on the anti-rotation pressure plates  $\Rightarrow$  to lock the pressure plates and prevent the pressure plate rotation during compression or in stressed position and the removal of stressed springs from the spring compressor.

### Special Pair of Pressure Plates with eccentric receiving bore (German Utility Model)

Part-No.	Spring range	Weight	Application
KL-0025-16 (size 0)	Spring-Ø: 95-110 mm Rise over 240°=6 mm	1,1 kg	<b>Mercedes</b> rear axle e.g. W211 (E-Class) W209 (CLK) <b>BMW</b> E87 (1 series) rear axle E90 (3 series) rear axle

### Description:

Due to the eccentric offset of the central hole, coil springs which have a pronounced bow may be safely compressed and removed and replaced without the need to dismantle the rear axle.

- High time savings

### Special Pair of Pressure Plates

Part-No.	Spring range	Weight	Application
KL-0025-17 (size 1.5)	Spring-Ø: 100-130 mm Rise over 270°=7 mm	1,9 kg	<b>Mercedes</b> rear axle M-Class (W164)

### Standard Pair of Pressure Plates

Part-No.	Spring range	Weight	Application
KL-0025-11 (size 1)	Spring-Ø: 95-120 mm Rise over 240°=6 mm	1,3 kg	<b>Mercedes</b> W116, W123, W124, W129, W201, W202, front axle; W124, W124 4-Matic, W129, W201, W202, rear axle ; <b>Saab ; Skoda ; Ford ; etc.</b>
KL-0025-12 (size 2)	Spring-Ø: 120-140 mm Rise over 240°=6 mm	1,8 kg	<b>Mercedes</b> W126, W140 front axle; W107, W114, W115, W 116, W123, W126, W140, W203 rear axle; <b>Opel; GM; Lada;</b> <b>Peugeot; Rover; Hyundai;</b> <b>Saab; Volvo; VW T 2; Ford</b> <b>Taurus; Mitsubishi; etc.</b>

### Special Pair of Pressure Plates

Part-No.	Spring range	Weight	Application
KL-0025-13 (size 3)	Spring-Ø: 100-155 mm Rise over 240°=20 mm	2,1 kg	<b>Ford Australien; GM;</b> <b>Ford-Taurus-Granada;</b> <b>Renault</b> rear axle; <b>VW LT</b> front axle; <b>Peugeot</b> rear axle; <b>etc.</b>
KL-0025-14 (size 4)	Spring-Ø: 155-190 mm Rise over 180°=25/15 mm	2,3 kg	<b>Renault</b> R25 rear axle; <b>Hummer; etc.</b>
KL-0025-5 (size 5)		1,8 kg	<b>Mercedes</b> W124 4-Matic front axle

1

KL-0016

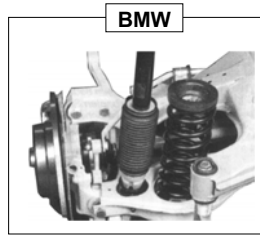
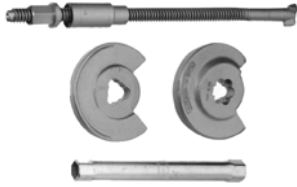

### KL-0016 Spring Compressor

For wishbone (front and rear axles) e.g. rear axle on **BMW 8 series** inkl. Pair of Pressure Plates Size 0.

This spring compressor allows replacement of the coil springs without the need to dismantle the rear axle.

The patented 3-point interlock ensures safe function of the tool.

Extension: 25-270 mm; Working travel: 245 mm;  
Max. load 20 000 N.

**Accessories:**

Pair of pressure plates **KL-0016-1** for Mercedes W124/W201

Pair of pressure plates **KL-0016-2** for Mercedes W123/W126

KL-0026

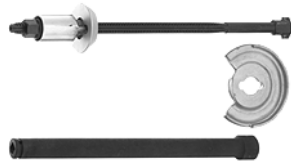

Jaguar XJ-6

### KL-0016-5 Spring Compressor (not illustrated)

As **KL-0016** but with 1 pair Pressure Plates size 1 (**KL-0016-1**).

Suitable for **Mercedes W124; W201**.

**Accessories:**

**KL-0016-2** Pressure Plates size 2 ( For MB W123; W126).

KL-0027



Aston Martin / Jaguar

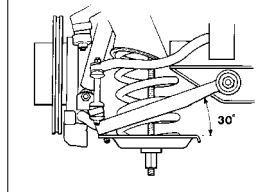

### KL-0026 Spring Compressor

For **Jaguar XJ-6**.

This spring compressor allows front springs to be removed and replaced quickly and safely. One-man operation - automatically adjusts to extreme spring-curvature.

### KL-0027 Spring Compressor

For **Jaguar XJ-S** and **Aston Martin**.

The compressing technique allows quick and safe replacement of front springs, together with easy alignment of the bottom spring plate to lower wishbone holes.

KL-0006-2



Universal

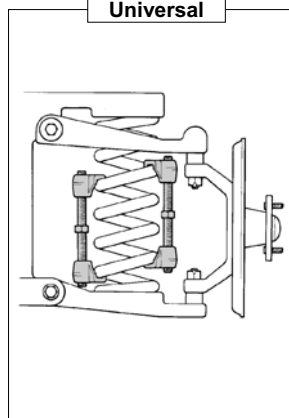

Spring compressed  
e.g. VW Golf IV



### KL-0006-2 Spring Compressor (Pair)

Allows the compressing of the spring at the car, so the strut can be taken out without dismantling the bearing housing.

This is important on the front axle of **VW** vehicles and on the rear axle of **Ford Mondeo**, etc. Time saving: ..... 1 - 2 hours

**Especially suitable for:**

⇒ **Step bearing suspension strut replacement**  
e.g. **VW Golf IV**

Thanks to the spring compressor **KL-0006-2** the step bearing suspension strut can be replaced inside the vehicle in a few minutes without having to remove and re-install the suspension strut.

**Expenditure of time about 15 minutes;**  
**Time saving about 1 hour.**

⇒ **Spring and shock unit removal and installation.**  
e.g. **VW Golf IV**

By using the spring compressor **KL-0006-2** springs can be compressed inside the vehicle without having to remove the axle box case/cardan shaft. In this way when the shock unit clamping hole has been opened by means of the expander **KL-0104-21**, the spring and shock unit can be easily taken out of the clamping hole.

**Expenditure of time about 10 minutes;**  
**Time saving about 30 minutes.**

Maximum Load: ..... 8 000 N      Compression Length: ... 65-200 mm

The spindles are equipped with contra-rotating threads which eliminate the risk of slipping round the spring. (Not suitable for use on Mercedes springs.)

**Note:** Refer to page 1-02 to see spring compressors for spring removal. Two part spring compressors without safety loop are not authorized in workshops.

KL-0005

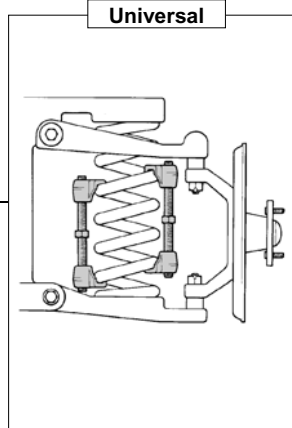

KL-0006



KL-..80 includes KL-0008



Change shock-absorber inserts without strut removal



KL-0008



Universal

KL-0008-1



KL-0008-12

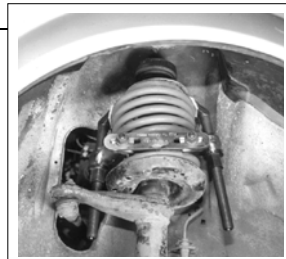

### KL-0005 Spring Compressor (Pair)

For use with MacPherson Struts in which Spring Pressure does not exceed 8 000 N.

The spindles are equipped with contra-rotating threads which eliminate the risk of slipping round the spring. (Not suitable for use on Mercedes springs.)

Max. Load: .. 8 000 N      Compression length: ... 65-320 mm

**Accessories:** KL-0005-1 Pair of spindles for self-levelling spring assemblies.

**Note:** Two part Spring Compressors without safety loop are not authorized in workshops.

### KL-0006 Spring Compressor (Pair)

For replacement of self levelling shock absorbers, particularly for rear axles on **Mercedes** and **Ford**.

Max. Load: .. 8 000 N      Compression length: ... 85-170 mm

**Advantages:**

- Contra-rotating threads to eliminate slip.
- Hex drive situated in the centre of the spindle permitting easy use in confined spaces where other spring-compressors cannot be used.

**Note:** Two part Spring Compressors without safety loop are not authorized in workshops.

### KL-..80 Tool Set for the fast shock absorber service (Patented)

For nearly every shock absorber insert without dismantling the MacPherson Strut.

Part No.	Description
KL-..80	Tool Set
<i>consists of:</i>	
KL-0008	Spring Compressor Universal (Pat.)
KL-0050-1	Box Spanner 29 mm hex, Drive 1/2"
KL-0050-2	Box Spanner 33.5 mm hex, Drive 1/2"
KL-0054	Tool Set Universal
KL-..80-0001	Plastic Storage Case (empty)

### KL-0008 Spring Compressor (Patented)

**KL-0008** Safety Spring Compressor which allows shock-absorber inserts to be exchanged on the vehicle, without the need to remove the strut from the vehicles.

Time savings:..... ½ - 2 hours  
 Maximum Load..... 10 000 N  
 Compression Length:..... 42-210 mm  
 Spring-Ø:..... 110-188 mm  
 Drive:..... hex 24 mm

### KL-0008-1 Spring Compressor (Patented)

As **KL-0008** but supplied with a special long impact socket **KL-0008-12** which allows operation of the spring compressor by a ½" impact gun.

### KL-0008-12 Special Impact Socket hex 24

Special long impact socket with 24 mm and ½"-square drive to operate Spring Compressor KL-0008-1 using an impact gun.

1

Manufacturer	Jaws for KL-9001 / KL-9002	Model	Jaws for KL-0015 / KL-2000	Model
Alfa Romeo	KL-9001-11	predominantly	KL-1500	156, 147
	KL-9001-12	33, 164, 147	KL-1510	predominantly
	KL-9001-13	145, 146, 155, GTV, Spider	KL-1520	predominantly
	KL-9001-15	156	KL-1590-1	156
Audi	KL-9001-10	80, A4, A8	KL-1500	80, A4
	KL-9001-11	predominantly	KL-1510	predominantly
	KL-9001-13	100, 200, A6	KL-1512	A4, A8
	KL-9001-32	Audi A8 (armoured)	KL-1514	A8
		KL-1516	A4	
		KL-1520	100, 200, A6	
BMW	KL-9001-11	predominantly	KL-1500	predominantly
	KL-9001-12	3 series (E36), Z3	KL-1510	predominantly
	KL-9001-13	5 series (E39), 7 series (E32), 7 series (E38), X5, X3	KL-1520	3 series (E36), Z3, X3
	KL-9001-1310	3 series (E46), 5 series (E39)	KL-1525	3 series (E46), 5 series (E39)
	KL-9001-1900	3 series (E46), 5 series (E39)	KL-1530	7 series (E38)
	KL-9001-1910	3 series (E46), 5 series (E39), Z8	KL-1571	3 series (E46), 5 series (E39)
		KL-1575	3 series (E46), 5 series (E39)	
			1 series (E87), 3 series (E90) (see also KL-0025-200)	
Chrysler	KL-9001-10	Stratus	KL-1500	Stratus
	KL-9001-11	LeBaron, Cherokee, Gr. Cherokee, Wrangler	KL-1510	predominantly
	KL-9001-12	Vision, New Yorker, Wrangler	KL-1512	Stratus
	KL-9001-13	predominantly	KL-1520	Neon, 300M, Vision, Wrangler
	KL-9001-15	Stratus	KL-1530	LeBaron, Vision, New Yorker
		KL-1590-1	Stratus	
Citroën	KL-9001-11	C15, AX, ZX, C2, C3	KL-1510	C15, AX, Saxo, ZX, Xsara, C2, C3
	KL-9001-12	Saxo, Xsara, Berlingo	KL-1520	Evasion, Berlingo, Jumpy
	KL-9001-13	Evasion, Jumpy, Jumper	KL-1550	C15
	KL-9001-14	C15		Evasion RA, Jumpy RA (see also KL-0021/KL-0025-1)
			Jumper	
Daewoo	KL-9001-10	Matiz	KL-1500	Matiz
	KL-9001-11	Lanos, Nubira	KL-1510	Lanos, Nubira
Daihatsu	KL-9001-10	Cuore, Sparcar	KL-1500	Cuore, Sparcar
	KL-9001-11	predominantly	KL-1510	predominantly
			Charade RA (see also KL-0021/KL-0025-1)	
Fiat	KL-9001-10	predominantly	KL-1500	Panda
	KL-9001-11	Uno, Fiorino, Croma, Punto	KL-1510	predominantly
	KL-9001-12	Cinquecento, Punto, Barchetta	KL-1520	predominantly
	KL-9001-13	predominantly, especially for Ducato		Ulysse RA, Scudo RA (see also KL-0021/KL-0025-1)
Ford	KL-9001-10	Fiesta, KA, Puma, Escort, Orion, Focus	KL-1500	Fiesta, KA, Puma, Escort, Orion
	KL-9001-11	predominantly	KL-1510	predominantly
	KL-9001-12	Mondeo	KL-1520	Mondeo, Galaxy, Probe
	KL-9001-13	Galaxy, Probe	KL-1561	Probe
				Escort RA, Orion RA (see also KL-0021/KL-0025-1)
Honda	KL-9001-10	predominantly	KL-1500	predominantly
	KL-9001-11	Legend	KL-1510	Accord, CR-V, Shuttle, Prelude, Legend
	KL-9001-12	Concerto, Civic, Stream	KL-1520	Concerto, Civic, Stream
			Shuttle RA (see also KL-0021/KL-0025-1)	
Hyundai	KL-9001-11	Atos, Accent	KL-1510	Atos, Accent
	KL-9001-12	Lantra, Coupe	KL-1520	Lantra, Coupe
Jaguar			KL-1511	XK8
			KL-1513	XK8
			KL-1590-1	XK8
				XJ-S (see also KL-0027)
			XJ-6 (see also KL-0026)	
Kia	KL-9001-10	Pride	KL-1500	Pride
	KL-9001-11	predominantly	KL-1510	predominantly
	KL-9001-13	Clarus	KL-1520	Clarus
Lada	KL-9001-10	Samara, Battic	KL-1500	Samara, Battic
	KL-9001-11	predominantly	KL-1510	predominantly
			Nova (see also KL-0021/KL-0025-1)	
Lancia	KL-9001-10	Y	KL-1510	Y10, Y, δ (Delta), Thema, κ (Kappa)
	KL-9001-11	Y10, δ (Delta), Thema, κ (Kappa)	KL-1520	predominantly
	KL-9001-12	Y, Prisma, Dedra, κ (Kappa)	KL-1530	γ (Gamma)
	KL-9001-13	δ (Delta), Dedra, Thema, Z (Zeta)	KL-1581 R	γ (Gamma)
			Z (Zeta) RA (see also KL-0021/KL-0025-1)	
Mazda	KL-9001-10	121, MX5, Xedos, 6, 929	KL-1500	121, MX5, Xedos, 6, 929
	KL-9001-11	predominantly	KL-1510	predominantly
	KL-9001-12	323, 626, MX3, MX6, Xedos	KL-1520	626, MX3, MX6, Xedos
	KL-9001-13	626	KL-1561	323, 626, MX6
Mercedes	KL-9001-10	A-Class, Smart, Vaneo	KL-1500	A-Class, Smart, Vaneo
	KL-9001-11	A-Class, M-Class	KL-1510	M-Class
	KL-9001-12	V-Class, Vito	KL-1520	Viano
	KL-9001-13	Viano		
	KL-9001-15	E-Class (W210)		
	KL-9001-17	E-Class (W211)		
	KL-9001-18	C-Class (W203), G-Class (W463)		
	KL-9001-3100	C-Class (W203), CLK (W209)		
	KL-9001-3110	C-Class (W203), CLK (W209)		
				For further spring compressors for Mercedes cars see KL-0021 / KL-0024 / KL-0025-1

**NOTE:** Repair instructions issued by Audi, BMW and Ford state that compression of coil-springs should only be performed using plastic protective inserts. **Plastic Protection Inserts are available upon request.**



Manufacturer	Jaws for KL-9001 / KL-9002	Model	Jaws for KL-0015 / KL-2000	Model
Mitsubishi	KL-9001-10	Colt, Carisma, Eclipse, Galant	KL-1500	Colt, Carisma, Eclipse, Galant
	KL-9001-11	predominantly	KL-1510	Colt, Lancer, Space Wagen, Galant, Sigma
	KL-9001-12	Colt, Lancer, Space Runner,	KL-1520	predominantly
	KL-9001-13	Sigma, Carisma, Space Wagon, Eclipse		
Mini			KL-1500	Cooper
			KL-1520	Cooper
			KL-1561	Cooper
Nissan	KL-9001-10	Micra	KL-1500	Micra, Primera
	KL-9001-11	predominantly	KL-1510	predominantly
	KL-9001-12	Pimera, 200SX	KL-1520	predominantly
	KL-9001-13	Maxima QX, Serena, Pathfinder, Primera	KL-1590-1	Primera, Pathfinder, Patrol
	KL-9001-15	Primera		
	KL-9001-17	Pathfinder, Primera		
				Micra RA (see also KL-0021/KL-0025-1)
Opel	KL-9001-10	predominantly rear axle	KL-1500	predominantly RA
	KL-9001-11	predominantly	KL-1510	predominantly
	KL-9001-12	Ascona C, Rekord E, Omega B, Senator, Monza, Sintra, Arena, Movana	KL-1512	Small Cars
			KL-1520	Ascona C, Rekord E, Omega B, Senator, Monza Sintra
				Wishbone RA (see also KL-0021/KL-0025-1)
Peugeot	KL-9001-11	104, 205, 305, 305 Break, 306, 309, 405	KL-1510	104, 205, 305, 305 Break, 307, 306, 309, 405,
	KL-9001-12	106, 206, 307, 406, 505, 605, 607, Partner	KL-1520	106, 206, 307, 406, 505, 604, 605, 607, 806, Partner, J5
	KL-9001-13	307, 604, 806, J5, Boxer		
	KL-9001-14	305 Break	KL-1550	305 Break
	KL-9001-1920	307		Boxer FA
				Wishbone RA (see also KL-0021/KL-0025-1)
Porsche	KL-9001-10	911, 928, 968	KL-1510	predominantly
	KL-9001-11	924, 944, Boxster	KL-1512	predominantly
			KL-1520	911, Boxster
Renault	KL-9001-11	predominantly	KL-1510	predominantly
	KL-9001-12	Predominantly especially for Master	KL-1520	Mégane, Laguna, R25, Espace, R9, R11, R14
	KL-9001-13	R21, Laguna, R25, Safrane, Espace	KL-1530	R21, Safrane,
			KL-1581-R	Laguna, Safrane
				Wishbone RA (see also KL-0021/KL-0025-1)
				Wishbone FA (see also KL-0035)
Rover	KL-9001-10	400, 600, Austin Montego	KL-1500	400, 600, Austin Montego
	KL-9001-11	predominantly	KL-1510	predominantly
	KL-9001-12	200	KL-1520	200, Freelander
	KL-9001-13	Freelander		Wishbone RA (see also KL-0021/KL-0025-1)
Saab	KL-9001-10	9-5	KL-1510	900, 9-3, 9-5
	KL-9001-11	predominantly	KL-1512	90, 900
	KL-9001-12	9000	KL-1520	9000
				Wishbone RA (see also KL-0021/KL-0025-1)
Seat	KL-9001-10	Terra, Ibiza, Cordoba, Toledo	KL-1500	Ibiza, Cordoba, Toledo
	KL-9001-11	predominantly	KL-1510	predominantly
	KL-9001-12	Alhambra	KL-1520	Alhambra
	KL-9001-17	Arosa	KL-1590-1	Arosa
Skoda	KL-9001-10	Fabia, Favorit, Felicia	KL-1500	Fabia, Favorit, Felicia
	KL-9001-11	Fabia, Favorit, Felicia, Octavia	KL-1510	Felicia, Favorit, Felicia, Octavia
				Wishbone Axles see also KL-0021/KL-0025-1
Smart	KL-9001-10	Smart	KL-1500	Smart
Ssang Yong	KL-9001-11	Korando, Musso	KL-1510	Korando, Musso
Subaru	KL-9001-10	Justy, Legacy, Libero	KL-1500	Justy, Libero, Legacy, Outback
	KL-9001-11	1800, Legacy	KL-1510	1800, Legacy,
	KL-9001-12	Legacy, Forester, SVX, Outback	KL-1520	Legacy, Forester, SVX, Outback
	KL-9001-13	Legacy, Forester, SVX, Outback		
Suzuki	KL-9001-10	Alto, Vitara, Jimmy, Wagon R+	KL-1500	Alto, Vitara, Wagon R+
	KL-9001-11	Swift, Baleno, Jimmy	KL-1510	Alto, Swift, Baleno, Jimmy
	KL-9001-12	Baleno	KL-1520	Baleno
Toyota	KL-9001-10	Starlet, Paseo, MR2	KL-1500	MR2
	KL-9001-11	predominantly	KL-1510	predominantly
	KL-9001-12	Avensis, Camry, Celica, Corolla, 4-Runner	KL-1520	Avensis, Camry, Corolla, Previa, RAV4, 4-Runner
	KL-9001-13	Camry, Previa, RAV4		
Volvo	KL-9001-10	S40, V40	KL-1500	S40, V40
	KL-9001-11	predominantly	KL-1510	predominantly
	KL-9001-12	440, 460, 480, 940, 960, S90, V90	KL-1520	predominantly
	KL-9001-13	S40, V40, S80		
VW	KL-9001-10	predominantly	KL-1500	Bora, Golf II, Golf III, Golf IV, Polo II, Polo III, Jetta II, Scirocco II, Vento
	KL-9001-11	predominantly		
	KL-9001-12	Sharan	KL-1502	Golf V
	KL-9001-13	T5	KL-1510	predominantly
	KL-9001-15	Lupo rear axle	KL-1520	Sharan, T5
	KL-9001-33 SP	Touareg	KL-1590-1	Lupo
				Bus T2, LT FA (see also KL-0021/KL-0025-1)

**NOTE:** Repair instructions issued by Seat, Skoda and VW state that compression of coil-springs should only be performed using plastic protective inserts. **Plastic Protection Inserts are available upon request.**

1

KL-0255

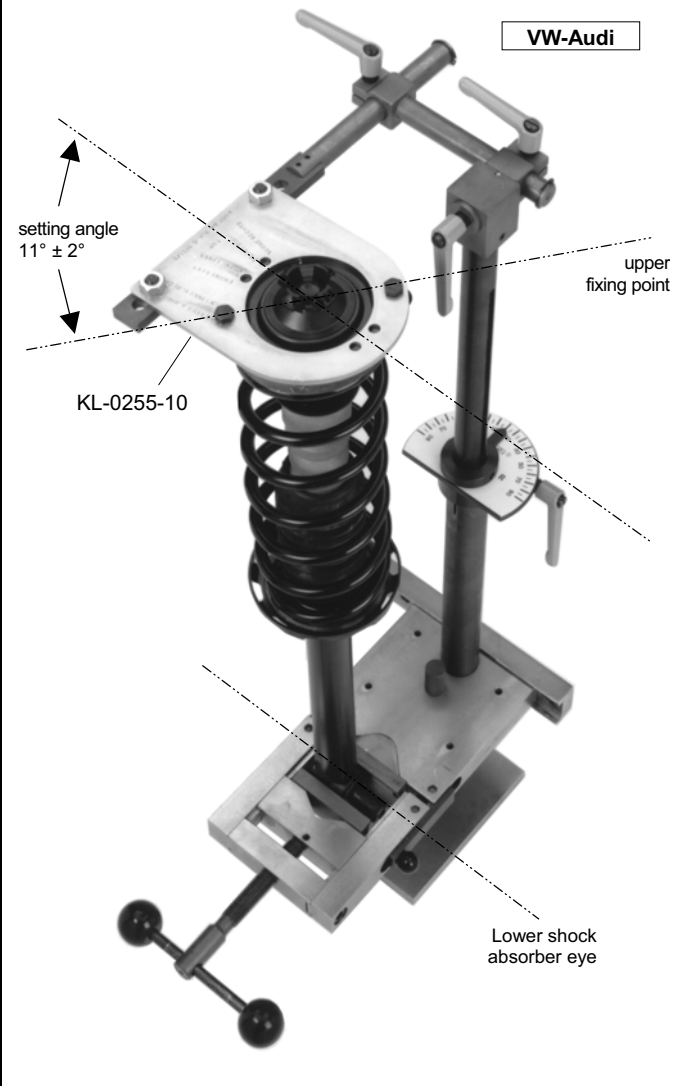

KL-0255 with KL-0015



### KL-0255 Strut Vise and Adjustment Tool (Patented)

For VW-Audi 1990 onwards.

This strut vise and adjustment tool establishes quick, easy and correct adjustment and repairs of struts on the workbench.

Due to the special design strut tubes can be clamped vertically and damper eye bolts can be clamped horizontally.

The built-in protractor permits exact positioning of the strut base-fixing in relation to the upper locating fixture.

#### Advantages:

1. Strut can be clamped quickly and easily.
2. Universal application for all struts with the same construction.
3. Strut tubes can be clamped vertically and damper eye bolts can be clamped horizontally.
4. The graduated protractor ensures compatibility with future suspension systems, unlike fixed struts.
5. The tool can be mounted on a bench or in a vise.

#### Note for Audi cars:

Suspension legs as fitted to the front and rear axles of Audi 80, Audi 100 from 1992 onwards inclusive Audi A4, A6 and VW Passat from 1996 onwards require installation with a pre-determined offset between the upper and lower fixture points, in order to permit problem-free installation.

It is essential to align the upper and lower mounting plates prior to installation of assembled strut.

If this prior alignment is not carried out, assembly will only be possible by forcing the mounting holes of the upper and lower plates, and this action of forcing will lead to premature failure of the ride-level control seal, noisy suspension and most often a pull to right or left in the steering which cannot be corrected by steering geometry alignment.

Weight: ..... 26 kg

#### ! Attention:

- Use only the Spring Compressor KL-0015 and protective inserts for VW-Audi.

#### Accessories:

**KL-0255-10 - Adjustment plate for Audi A4**  
(B5 from '96 - '01), front and rear axle.



#### Parameters:

Audi 80/90 rear axle .....	21° ± 2°
Audi 100 Quattro from '91 onwards rear axle .....	51° ± 2°
Audi 100 (Front WD) from '91 onwards rear axle .....	45° ± 2°
Audi A4 front axle .....	11° ± 2°
Audi A4 rear axle .....	50° ± 2°
Audi A6 from '97 onwards .....	11° ± 2°
VW Passat from '96 onwards .....	11° ± 2°

### KL-0255-11

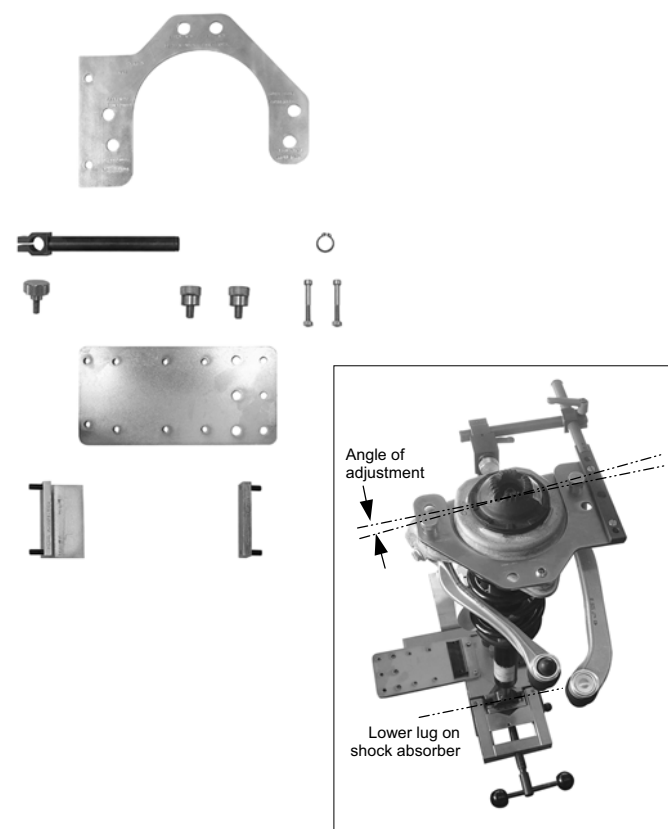

### KL-0255-11 Additional tool set for Audi A6 (for use with adjusting fixture KL-0255) (German Utility Model)

Suitable for Audi A6 (04/04 onwards) front axle.

The additional tool set, when used with the clamping and adjusting fixture **KL-0255**, makes clean, quick adjustment of the spring plate possible in relation to the retaining lug of the shock absorber strut.

With the adjusting gauge, the precise amount of offset between the lower shock absorber strut mounting and the upper spring plate can be adjusted correctly (see picture).

#### Note for VW and Audi vehicles:

The front spring/shock absorber struts on VW-Audi vehicles must be pre-adjusted on the workbench, so that the upper mounting point (the spring plate) and the lower shock absorber strut mounting (fork/shock absorber lug) are correctly aligned with one another.

Unless this work is undertaken first, the shock absorber strut cannot be installed, because the fastening points between the shock absorber strut and the body/axle beam will not be aligned.

If the shock absorber strut mounting is forced into the correct position, the O-rings for level control will be damaged and the shock absorber strut will be **distorted**, which could lead to drumming noise and cause the vehicle to handle incorrectly.

### KL-0055-50

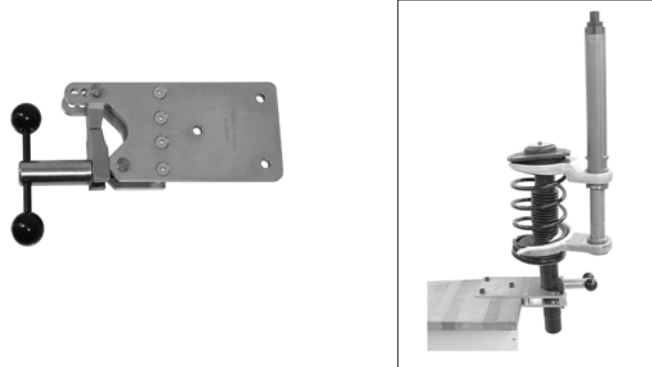

### KL-0055-50 Holding Fixture (German Utility Model)

For MacPherson Struts, Shock-Absorbers and Steering Racks.

The strut vise has to be screwed on the workbench and enables a clean, safe and quickly repairing.

Strut axles should NOT be tensed in a vice for mounting (deformation).

### KL-9055-1

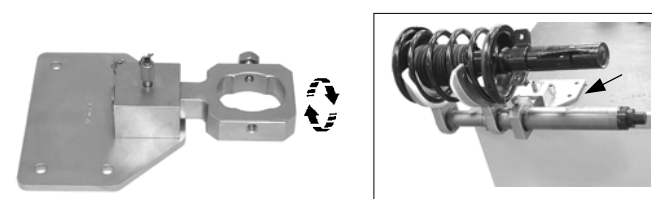

### KL-9055-1 Holding Fixture

Holding Fixture for the Spring Compressors **KL-9002** and **KL-9001**. The Fixture can rotate through 360° so allowing Struts to be clamped horizontally or vertically.

### KL-9055-2

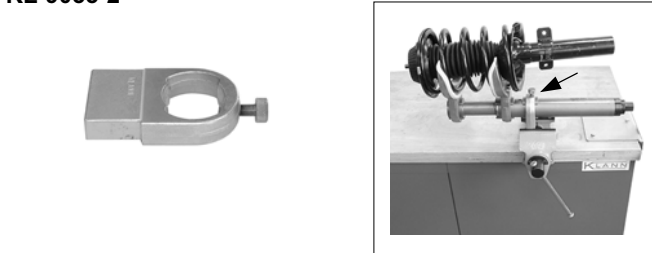

### KL-9055-2 Holding Fixture

Holding Fixture suitable for the Spring Compressors **KL-9002** and **KL-9001**.

1

KL-0054-K



**Contents:**

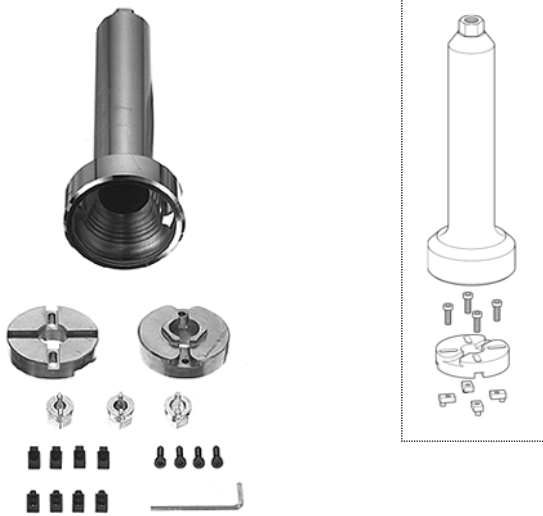

**Accessory: KL-0054-0051**



**The Problem:** Wide variety of Body-Nut profiles used to retain shock-absorber inserts.

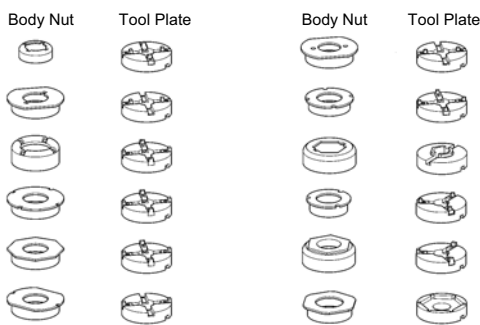

Special Socket



## Shock Absorber Service Tools

For the Shock Absorber Service.

The use of KLANN Tool Sets **KL-0050**, **KL-0051**, **KL-0052 K** or **KL-0054 K** guarantees damage-free removal and replacement of Body Nuts during replacement of shock absorber cartridge inserts.

Stubborn or corroded Body Nuts are quickly and easily undone. The inclusion in the Tool Sets of flat and round profiled inserts allows the universal application of the correct tool-profile for every type of Body Nut.

The Special Socket **KL-0054-0010** included in the **KL-0054 K** Tool Set allows easy removal and replacement of Body Nuts on Gas shock absorbers which have strengthened damper-rods (except "Bilstein"). The drive-head of the Special Socket incorporates a series of steps for direct application to Body Nuts with dimensions 46, 51, 55, 58 and 60 mm.

The shock absorber body nuts can also be loosened by putting on directly the extension nut **KL-0054-0010**.

### KL-0054-K Strut Nut Tool Kit

**Universal**

For nearly every shock absorber insert nut including Garbon Gas Shocks (Bilstein excepted).

This Tool Set replaces KL-0050 / KL-0051 / KL-0052

- Quick
- Safe
- Clean

**Contents:**

Part-No.	Description	Qty.
<b>KL-0054-K</b>	<b>Strut Nut Tool Kit Universal</b>	<b>1</b>
<i>consists of:</i>		
KL-0050-0022	Screw M6 × 18 Din 7984	4
KL-0050-0023	Allen Key 4 mm	1
KL-0050-0025	Round Key	4
KL-0050-0027	Flat Key	4
KL-0050-0070	Drive Nut Set (Set of 3 Sockets)	1
KL-0054-0010	Extension Socket	1
KL-0054-0011	O-Ring	1
KL-0054-0021	Plate, 90° Universal	1
KL-0054-0035	Plate for VW-Audi	1
KL-0054-0090	Storage Case	1

**Accessory:**

Part-No.	Description	Qty.
KL-0054-0051	Plate 120° Division without Key	1

### KL-0050

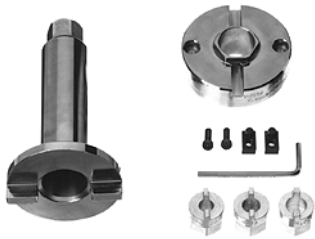

VW- Audi, Seat, Škoda



### KL-0051



### KL-0051-5



Universal

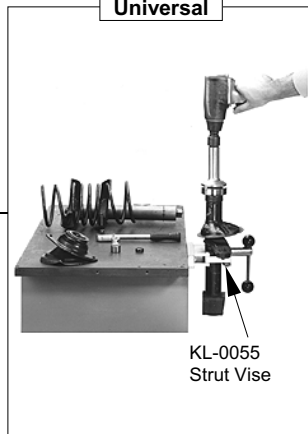

### KL-0052-K



KL-0055  
Strut Vise

### KL-0050 Strut Nut Tool Kit

For shock absorber insert nuts on **VW-Audi** including Special Drive Nut Set **KL-0050-0070** for slotted damper-rod nuts.

Part-No.	Description	Qty.
<b>KL-0050</b>	<b>Strut Nut Tool Kit</b>	<b>1</b>
<i>consists of:</i>		
KL-0050-0010	Extension Socket	1
KL-0050-0022	Screw M6 x 18	2
KL-0050-0023	Allen Key 4 mm	1
KL-0050-0035	Plate for VW-Audi (29 mm & 33.5 mm hex)	1
KL-0050-0036	Key for VW-Audi	2
KL-0050-0070	Drive Nut Set (Set of 3 Sockets)	1
<b>Accessory:</b>		
KL-0050-0090	Plastic Storage Case	1

### KL-0051 Strut Nut Tool Kit

For shock absorber insert nuts suitable for **European vehicles** (except Gas Shocks).

- Eliminates the use of pipe wrenches
- Eliminates the use of hammer and chisel
- Eliminates the use of welding torches

Part-No.	Description	Qty.
<b>KL-0051</b>	<b>Strut Nut Tool Kit</b>	<b>1</b>
<i>consists of:</i>		
KL-0050-0010	Extension Socket	1
KL-0050-0021	Plate, 90° - Universal	1
KL-0050-0022	Screw M6 x 18	4
KL-0050-0023	Allen Key 4 mm	1
KL-0050-0025	Round Key	4
KL-0050-0027	Flat Key	4
KL-0050-0035	Plate for VW-Audi (29 mm & 33.5 mm hex)	1
KL-0050-0070	Drive Nut Set (Set of 3 Sockets)	1
<b>Accessory:</b>		
KL-0050-0090	Plastic Storage Case	1

### KL-0051-5 Strut Nut Tool Kit

Part-No.	Description	Qty.
<b>KL-0051-5</b>	<b>Strut Nut Tool Kit</b>	<b>1</b>
<i>consists of:</i>		
KL-0050-0010	Extension Socket	1
KL-0050-0021	Plate, 90° - Universal	1
KL-0050-0022	Screw M6 x 18	4
KL-0050-0023	Allen Key 4 mm	1
KL-0050-0025	Round Key	4
KL-0050-0027	Flat Key	4
KL-0050-0035	Plate for VW-Audi (29 mm & 33.5 mm hex)	1
KL-0050-0060	Plate, 60 mm hex for GM Opel/Vauxhall	1
KL-0050-0071	Drive Nut Set (Set of 4 Sockets)	1
<b>Accessory:</b>		
KL-0050-0090	Plastic Storage Case	1

### KL-0052-K Strut Nut Tool Kit Universal

For shock absorber insert nuts for nearly all vehicles including Japanese (Gas Shocks excepted).

- **Quick**
- **Safe**
- **Clean**

Part-No.	Description	Qty.
<b>KL-0052-K</b>	<b>Strut Nut Tool Kit Universal</b>	<b>1</b>
<i>consists of:</i>		
KL-0050-0010	Extension Socket	1
KL-0050-0021	Plate, 90° - Universal	1
KL-0050-0022	Screw M6 x 18	4
KL-0050-0023	Allen Key 4 mm	1
KL-0050-0025	Round Key	4
KL-0050-0027	Flat Key	4
KL-0050-0035	Plate for VW-Audi (29 mm & 33.5 mm hex)	1
KL-0050-0050	Plate, 120° for Japanese Cars	1
KL-0050-0060	Plate, 60 mm hex for GM Opel/Vauxhall	1
KL-0050-0070	Drive Nut Set (Set of 3 Sockets)	1
KL-0050-0090	Plastic Storage Case	1

1

### KL-0250-1



VW-Audi, Seat, Škoda



### KL-0250-1 Strut Tool

For removal and replacement of the rear shock absorbers on **VW-Audi, Ford, Opel, Japanese cars, etc.** 5 mm and 6 mm hex.

### KL-0101

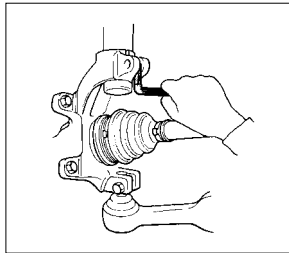
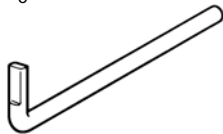
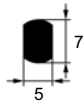

### KL-0101 Pry Bar for Hub Castings

#### Application:

**Ford, VW-Audi, Peugeot, Renault, Citroën, Japanese cars, etc.**

So that the spring/shock absorber unit can be pulled out of the bore in the steering knuckle even if it is a tight fit, it is essential to open out the clamping bore with pry bar **KL-0101**.

Chisels or Screwdrivers should never be used to spread the casting!

Length: .....205 mm      Breadth: .....5 mm  
Pry Width: .....7 mm      Weight: .....65 g

### KL-0101-1

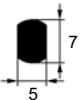

VW-Audi, Ford, Peugeot

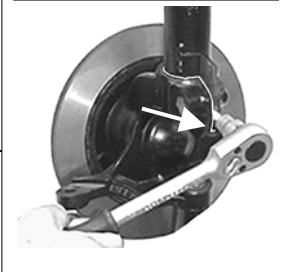

### KL-0101-1 Pry Socket 5 mm

#### Suitable for semi-strut clamp-castings on:

**VW-Audi, BMW, Citroën, Ford, Seat, Škoda, Renault, Peugeot, Japanese cars, etc.**

So that the spring/shock absorber unit can be pulled out of the bore in the steering knuckle even if it is a tight fit, it is essential to open out the clamping bore with pry socket **KL-0101-1**. Also required for easy insertion of the replacement Strut into the hub. Eliminates risk of damage to the hub casting and eliminates risk of accidents which can result from the use of hammers and chisels.

Drive: ..... 1/2"      Length: .....60 mm  
Weight: .....75 g      Breadth: .....5 mm  
Pry width: .....7 mm

### KL-0101-2

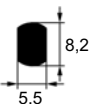

### KL-0101-2 Pry Socket 5.5 mm

#### Suitable for semi-strut clamp-castings on:

**VW Golf IV, Audi TT, VW-Audi, BMW, Citroën, Ford, Seat, Škoda, Renault, Peugeot, Japanese cars, etc.**

As **KL-0101-1** but with **5.5 mm** and Pry Width **8.2 mm**.

Drive: ..... 1/2"      Length: .....50 mm  
Weight: .....75 g      Breadth: .....5.5 mm  
Pry Width: .....8.2 mm

### KL-0168-90 K



Universal

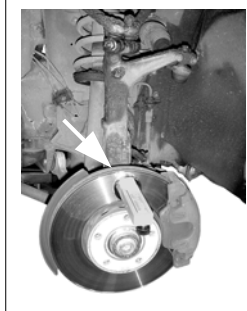

### KL-0168-90 K Camber Gauge (in Case)

The **KL-0168-90 K** Camber Gauge with magnetic foot allows the existing camber angle to be memorised before the suspension is dismantled. After reassembly the camber can be set to the previous setting without timeconsuming geometry check.

Weight: .....500g

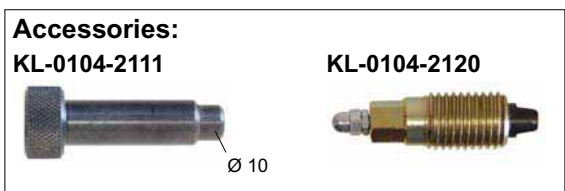
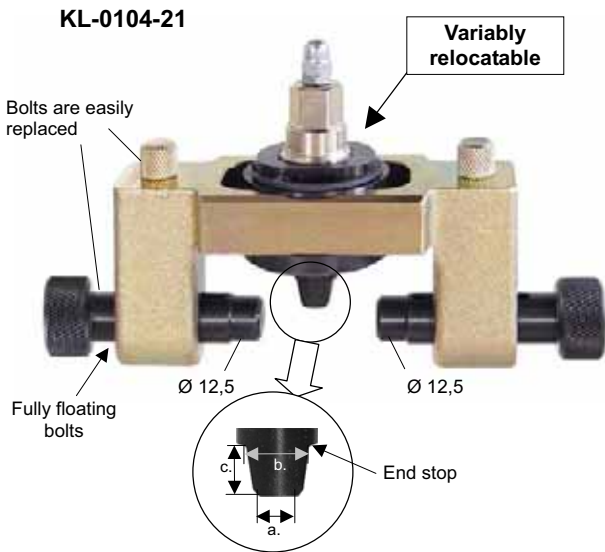

**KL-0104-21 Spreader tool (univ.)**  
(German Utility Model)

**Suitable for strut clamping bores on (for example):**  
**VW Golf V, Passat; Audi; BMW; Citroën; Ford; Seat; Škoda; Renault; Peugeot; Japanese vehicles etc.**

So that the spring/shock absorber unit can be pulled out of the bore in the steering knuckle even if it is a tight fit, it is essential to open out the clamping bore with spreader tool **KL-0104-21**. After this, the shock absorber unit can be removed or installed without difficulty, without risk of damaging the (cast iron or aluminium) steering knuckle.

Due to the variably relocatable spreading head it is especially suitable for vehicles whose fastening slot is out of centre such as VW-Audi, Ford etc.

Due to its dimensions and special form the replaceable wedge of the spreading head is particularly suitable for *aluminium knuckles*. The wedge is provided with an end stop to avoid excessive knuckle widening. Other wedges are available as accessories (e.g. for steel knuckles).

Fully floating bolts avoid the tool canting during knuckle widening.

**Technical Data:**  
 Mounting hole breadth (max.): ..... 60 mm  
 Widening dimensions (widening wedge): a: 5,8 mm; b: 8,5 mm; c: 4,5 mm  
 Weight: ..... 900 g

**Accessories:**  
**KL-0104-2111 Bolts Ø10 mm**  
 Suitable for M12 tapped holes e.g. for VW T5  
 (required for knuckle bores with internal thread)

**KL-0104-2120 Drive screw with wedge**  
 Particularly suitable for *steel knuckles*.  
**Technical Data:**  
 a. : .....5,9 mm      b. : ..... 8 mm      c. : ..... 7 mm

**KL-0104-20 Spreader tool (univ.)**  
(German Utility Model)

**Suitable for VW-Audi, BMW, Citroën, Ford, Seat, Škoda, Renault, Peugeot, Japanese vehicles etc.**

As **KL-0104-20** but with fixed spreading head.



1

### KL-0050-100

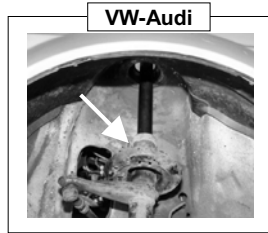
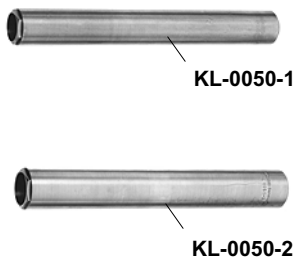

### KL-0050-100 Special Socket Set

Extra long Special Sockets to loosen or tighten the gland nuts retaining shock-absorber inserts on **Audi 80, 90, 100, 200, A6; VW Polo, Golf, Jetta, Vento, Passat**, etc.

Consists of:

**KL-0050-1 Special Socket 29 mm hex** suitable for Audi 80/90, VW Polo, Golf, Jetta, Vento, Passat, etc.

**KL-0050-2 Special Socket 33,5 mm hex** suitable for Audi 100, 200, A6

### KL-0050-50



### KL-0050-50 Special Toothed Socket

For removal of damper rod nuts on **Mercedes W203 (C-Class), W209 (CLK)** front axle.

### KL-0050-510



### KL-0050-510 Damper Rod Tool Set

Suitable for **Mercedes W203 (C-Class), W209 (CLK)** front axle.

To loosen or tighten the Damper Rod Nut

Consists of:

**KL-0050-51 Toothed Socket (drive: 22 mm hex)**

**KL-0056-52 7 mm Allen Key Socket Insert**

**Accessories:**

**KL-0056-21 - Hex Socket 21 mm**

To loosen the Damper Rod Fastening Nut from the body.

### KL-0050-0001 to KL-0050-0007



### KL-0050-0001 to KL-0050-0007

**Damper Rod Lifting Tools.**

Part No.	Inner -Thread	Examples
KL-0050-0001	M12×1.25	BMW
KL-0050-0002	M15×1.5	GM/Opel
KL-0050-0003	M12×1.5	Audi
KL-0050-0005	M10×1	Renault
KL-0050-0006	M14×1.5	VW-Audi, Opel
KL-0050-0007	M10×1.5	BMW



### KL-0050-0070



VW-Audi, Austin,  
Seat, Škoda



### KL-0050-0071



### 25 PK- Series

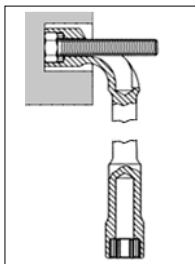

**Note:**  
For further information see GEDORE catalog.

### KL-0050-0070 Toothed Socket Set (3 Pcs.)

Drive Nut for Shock Absorber Damper Rods.

Part No.	Description	Bore	for
<b>KL-0050-0070</b>	<b>Toothed Socket Set</b>		
<i>consists of:</i>			
KL-0050-0012	Toothed Socket	10,5 mm	VW Golf rear axle
KL-0050-0013	Toothed Socket	12,5 mm	VW Polo front axle
KL-0050-0014	Toothed Socket	14,5 mm	Polo, Golf, Passat, Audi 80, Vento
<b>Accessory:</b>			
KL-0050-0015	Toothed Socket	14,5 mm	Austin Maestro

### KL-0050-0071 Toothed Socket Set (4 Pcs.)

Drive Nut for Shock Absorber Damper Rods.

Part No.	Description	Bore	for
<b>KL-0050-0071</b>	<b>Toothed Socket Set</b>		
<i>consists of:</i>			
KL-0050-0012	Toothed Socket	10.5 mm	VW Golf rear axle
KL-0050-0013	Toothed Socket	12.5 mm	VW Polo front axle
KL-0050-0014	Toothed Socket	14.5 mm	Polo, Golf, Passat, Audi 80
KL-0050-0015	Toothed Socket	14.5 mm	Austin Maestro

### 25 PK- Series Double ended socket wrench angled, with hole

GEDORE socket wrench Heavy duty pattern with two hexagon heads and Through-hole on the angled side to take long studs or a tommy bar. Chrome-plated.

**Available Sizes (hex):**

9 mm, 10 mm, 11 mm, 12 mm, 13 mm, 14 mm, 16 mm, 17 mm, 18 mm, 19 mm, 21 mm, 22 mm, 24 mm, 27 mm, 30 mm, 32 mm, 34 mm, 36 mm.

1

KL-0056-1

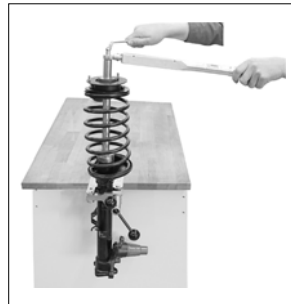

### Composition of Damper Rod Tool Set: KL-0056-1

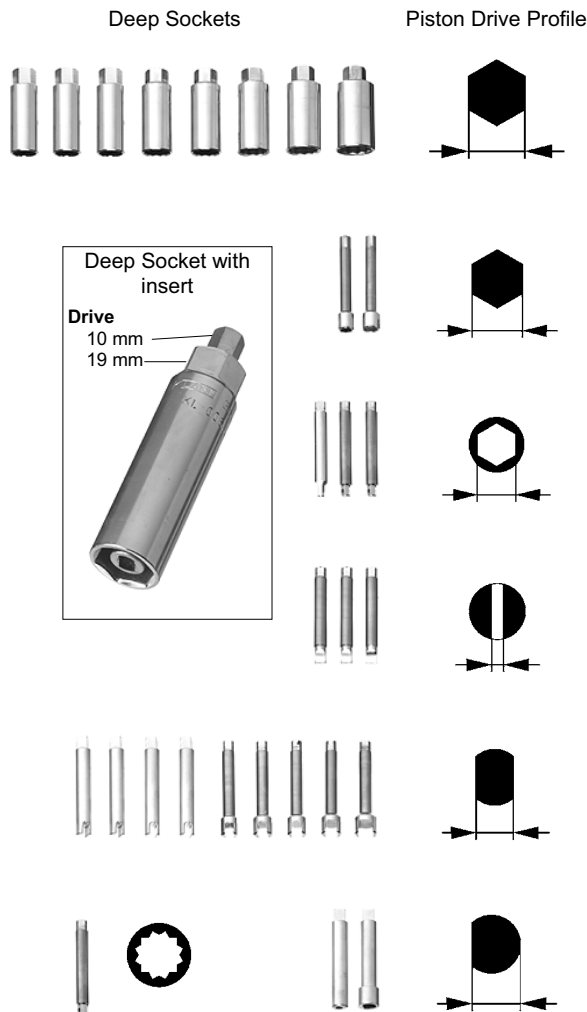

### KL-0056-1 Damper Rod Tool Set

Designed to stop the damper-rod from rotating while the retaining nut is removed or replaced. Allows the use of a torque-wrench to achieve the correct torque without the risk of the damper-rod rotating.

#### Contains:

- 8 deep sockets 14, 16, 17, 18, 19, 21, 22, 27 mm with drive 19 mm;
- 20 different profiles of damper-rod with drive 10 mm;
- Storage Case (440 × 340 × 100 mm)

#### Composition and Usage:

##### Deep Sockets, Length 82 mm

Part No.	Description	for:
KL-0056-14	Hex Socket 14 mm	Nissan
KL-0056-16	Hex Socket 16 mm	VW-Audi, Seat, Fiat
KL-0056-17	Hex Socket 17 mm	VW-Audi, Seat, Fiat
KL-0056-18	Hex Socket 18 mm	VW-Audi, Seat, Citroën, Fiat, Opel/Vauxhall, Peugeot, Renault, Jap. cars
KL-0056-19	Hex Socket 19 mm	VW-Audi, Seat, Citroën, Fiat, Opel/Vauxhall, Peugeot, Renault, Jap. cars
KL-0056-21	Hex Socket 21 mm	VW-Audi, BMW, Mercedes, Jap. Cars, Volvo
KL-0056-22	Hex Socket 22 mm	VW-Audi, Seat, Citroën, Fiat, Opel/Vauxhall, Peugeot, Renault
KL-0056-27	Hex Socket 27 mm	VW-Audi, Citroën, Peugeot

##### Socket Inserts

Part No.	Description	for:
KL-0056-43	Hex Insert 9 mm	Opel/Vauxhall
KL-0056-45	Hex Insert 11 mm	Japanese cars
KL-0056-51	Allen Key 6 mm	BMW, Seat, Fiat, Citroën, Peugeot, Opel/Vauxhall, Renault, Jap. cars
KL-0056-52	Allen Key 7 mm	VW-Audi, Seat, Fiat, Citroën, Mercedes, Peugeot, Renault
KL-0056-53	Allen Key 8 mm	Mercedes
KL-0056-60	Insert Slit 3 mm	Opel/Vauxhall, Renault
KL-0056-61	Insert Slit 3.5 mm	Citroën, Peugeot
KL-0056-62	Insert Slit 4 mm	Citroën, Peugeot
KL-0056-70	Double Flat 4 mm	Nissan
KL-0056-71	Double Flat 5.2 mm	VW-Audi, Nissan
KL-0056-72	Double Flat 6 mm	VW-Audi, Renault
KL-0056-73	Double Flat 6.3 mm	Nissan
KL-0056-74	Double Flat 7 mm	VW-Audi, Seat, Fiat
KL-0056-75	Double Flat 8 mm	Seat, Fiat
KL-0056-76	Double Flat 9 mm	Japanese cars, Volvo
KL-0056-77	Double Flat 10 mm	Seat, Fiat
KL-0056-78	Double Flat 12 mm	Seat, Fiat
KL-0056-81	Single Flat "D" 5 mm	Nissan
KL-0056-86	Single Flat "D" 10 mm	Nissan
KL-0056-96	Inner Spline 12 mm	Opel/Vauxhall

#### Case:

Part No.	Description
KL-0056-1020	Plastic Storage Case (440 × 340 × 100 mm)

#### Accessories: (Not Illustrated)

Part No.	Description	Qty
KL-0056-50	Allen Key 5 mm	1
KL-0056-35	Torx Insert T40 (VW, Porsche)	1

#### Example for Application:

KL-0056-18 + KL-0056-35 suitable for Porsche Cayenne / VW Touareg etc.