



Mercedes-Benz

## **EPC-Compact**

### **User Documentation**

- **Version for Windows NT 4.0**
- **Windows 95**
- **Windows 98**

© 1999 Copyright DaimlerChrysler AG

This document with all its sections is protected under the laws of copyright.

Its use for any purpose whatsoever requires the prior written consent of DaimlerChrysler AG.

This applies in particular to its reproduction, distribution, modification, translation, recording on microfilm or storage and/or processing in electronic systems, including databases and on-line services.

Produced by:

DaimlerChrysler AG, Stuttgart

PRODUCT MANAGEMENT PARTS CATALOGUING

Edition 08/1999

## Contents

	Preface .....	1
1	General .....	2
1.1	System Platforms for EPC-Compact .....	2
1.2	Abbreviations .....	2
2	Basics .....	3
2.1	Using the Mouse .....	3
2.2	Using the Keyboard .....	4
2.3	Screen Areas .....	6
2.3.1	Menu Bar .....	8
2.4	Toolbar .....	11
2.4.1	Information Area .....	12
2.4.2	EPC Message Line .....	14
2.5	Control Elements .....	15
2.5.1	Information Field .....	15
2.5.2	Input Fields .....	16
2.5.3	Action Button .....	17
2.5.4	Page Arrow .....	18
2.5.5	Selection List .....	19
2.5.6	Selection Lists with Input Fields .....	19
2.5.7	Selection Lists with Individual Selections .....	21
2.5.8	Selection Lists with Multiple Selections .....	22
2.6	Submenus .....	23
2.7	Pop-Up Menus .....	24
2.8	Help .....	25
3	EPC Access Paths .....	26
3.1	EPC Access Paths in Conjunction with the Vehicle ID Number .....	27
3.2	EPC Access Paths in Conjunction with Type or Model .....	28
4	EPC Initial Screen .....	29
4.1	World Manufacturer Code .....	31
4.2	Warning .....	32
5	Model Index .....	33
6	Catalogue Index .....	34
6.1	Model Overview .....	35
7	Data Card .....	36
8	Information Page .....	37
9	Finding SAs .....	39
10	Filter Menu .....	40
11	Standard Group Index .....	43
12	Aggregate Index .....	44
13	SA Index (Special Versions Index) .....	45
14	SA Stroke Index .....	46
15	Standard Sub-Group Index .....	47
16	Illustrated Page .....	48
16.1	Enlarging Illustrated Pages .....	51
16.2	This Illustration is not Available at this Time .....	52
16.3	All records - F6 .....	53
17	Parts Information/SA Parts Information .....	54
17.1	Parts Information for Standard Illustrated Pages .....	54
17.2	Parts Information for SA Illustrated Pages .....	57
17.3	Footnotes .....	58
17.4	Duplicate Part .....	59
18	Selected Parts List .....	60

18.1	List Menu .....	62
18.1.1	Add Part Number .....	63
18.1.2	Change Designation .....	64
18.1.3	Change Quantity .....	65
18.1.4	Change Code .....	66
18.1.5	Delete Code .....	67
18.1.6	Change Remarks .....	68
18.1.7	Delete Remarks .....	69
18.1.8	List Update .....	70
18.2	Util (List Utilities) .....	71
18.2.1	Save Current List .....	72
18.2.1.1	Save Current List to an Existing Folder .....	72
18.2.1.2	Save Current List to a New Folder .....	74
18.2.2	Clear Current List .....	75
18.2.3	Recall a Saved List .....	75
18.2.4	Copy a List .....	75
18.2.5	Delete a Saved List .....	76
18.2.6	Delete Folder .....	76
18.3	Parts Order .....	77
19	Add .....	79
19.1	Add Part Number .....	79
19.1.1	Add Part Qty .....	80
19.2	ES Code Input (only possible in the parts information) .....	81
20	Displaying Images/Text .....	82
21	Printing .....	83
22	SYSX Menu .....	84
23	DBCP Configuration .....	85
24	Application Index .....	86
24.1	Shop Materials (Class Index) .....	87
24.1.1	Shop Material Group Index .....	88
24.1.1.1	Shop Materials (Parts Information) .....	89
24.2	About DC EPC .....	90
	Index .....	91

---

## Preface

EPC-Compact is a system developed by DaimlerChrysler AG together with its specialist partners. It is used by the Parts divisions of DaimlerChrysler AG and its partners to determine part numbers automatically using a CD-ROM and the computer screen.

The system provides the following range of functions:

- It enables you to determine parts quickly, with or without access to vehicle data.
- It contains the parts documentation for the current commercial vehicle and passenger car ranges since approx. 1962 and the vehicle data cards since approx. 1978.
- It allows you to call up the parts of a vehicle which are available.

The user documentation is combined with the "EPC-Compact" course to provide you with the knowledge you need to make optimum use of the "EPC".

General issues relating to the EPC are presented in a comprehensible way and illustrated with text and pictures.

A clear list of contents provides you with quick access to the individual sections in this documentation.

A detailed, alphabetical index facilitates access to all the important terms used in this text.

The instructions provided in the user documentation are based on the software version

**Release:** 10.3.7

**CD Release:** 07/1999



This user documentation is not intended for self-study purposes.

Detailed knowledge on Mercedes-Benz products and the structure of the MB parts documentation is a prerequisite.

This documentation was developed and compiled by DAI  
on behalf of PRODUCT MANAGEMENT PARTS CATALOGUING.

PRODUCT MANAGEMENT PARTS CATALOGUING 08/1999

## 1 General

With the "EPC-Compact" system, DaimlerChrysler AG aims to improve the availability and usefulness of the parts documentation on the screen by optimizing access and using automatic evaluations in conjunction with the data card.

EPC-Compact replaces microfiche.

EPC-Compact contains the parts documentation for the current commercial vehicle and passenger car ranges since approx. 1962 and the vehicle data cards since approx. 1978.

### EPC-Compact:

- Modern, electronic parts documentation system to replace microfilm and paper formats.
- Update and dispatch of data CDs every six months.
- Easy to use.
- System operation with mouse or keyboard.
- Quick and reliable access to parts information.
- Access to the vehicle data card.
- Vehicle-specific parts determination.

### 1.1 System Platforms for EPC-Compact

EPC-Compact is available for the following system platforms:

- Windows NT 4.0
- Windows 95
- Windows 98

### 1.2 Abbreviations

Abbreviation	Meaning
<b>BM</b>	Model
<b>CD-ROM</b>	Compact Disk (Read-Only Memory)
<b>DK</b>	Data Card
<b>DP</b>	Data Processing
<b>EPC</b>	Electronic Parts Catalogue
<b>ES-CODE</b>	Supplementary CODE
<b>VIN</b>	Vehicle ID Number
<b>GA</b>	Automatic Transmission
<b>GM</b>	Manual Transmission
<b>GR</b>	Group
<b>ID</b>	Identification
<b>KB</b>	Code Letter
<b>LL</b>	Left-hand Drive
<b>NB</b>	As Required
<b>RL</b>	Right-hand Drive
<b>SA</b>	Special Version
<b>VB</b>	Sales Designation

## 2 Basics

**i** This section provides you with information that is an essential prerequisite for operating the EPC. It explains the control elements in detail.

You can perform all actions in the EPC-Compact using the mouse or keyboard.

### 2.1 Using the Mouse

You can perform the following operations in the EPC using the **left** or **right** mouse button.

**Left mouse button** You click the left mouse button to make selections that usually trigger an action in the EPC.

Examples:

- Selecting an illustrated item,
- Selecting an item in a selection list,
- Activating a function from the menu bar,
- Activating an action button,
- Activating/deactivating parts in the parts information or selected parts list.

**Right mouse button** You click the right mouse button to trigger functions. This button performs the same function as the **Return** key.

Examples:

- Confirming inputs in input fields,
- Returning to screens which have a higher position in the hierarchy (e. g. returning from the sub-group selection list to the group selection list),
- Closing submenus.

**Middle mouse button** **i** The **middle** mouse button **does not** have any functions in the EPC.





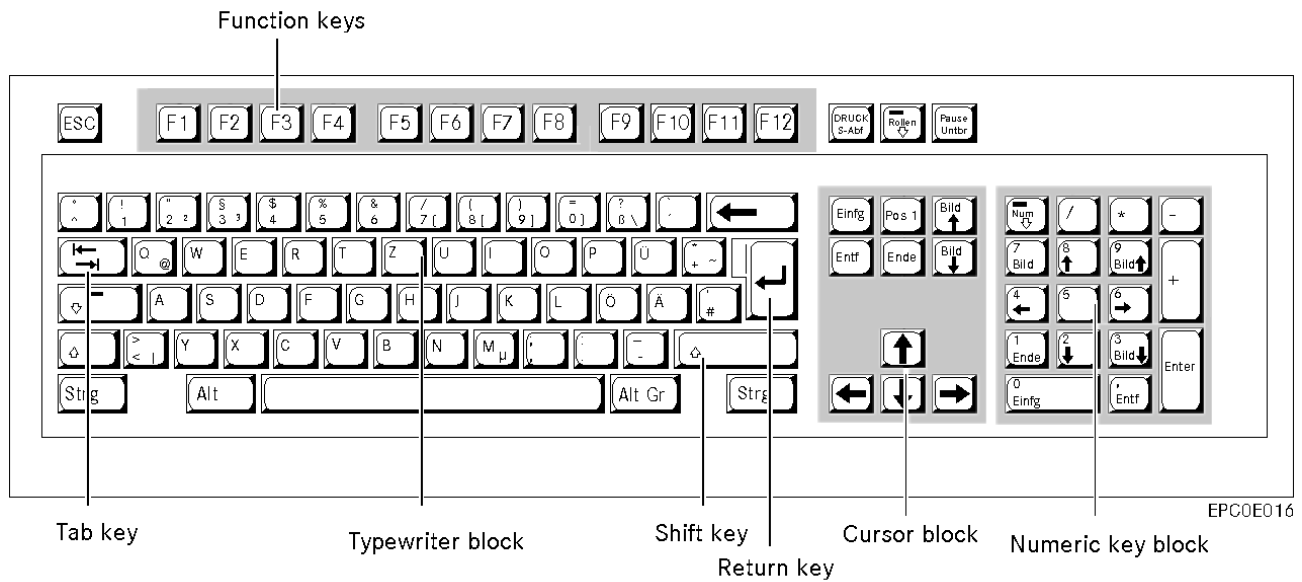











## 2.2 Using the Keyboard

The keyboard is an input device which you can use to send commands to the EPC.



### Meaning and Function of the Keys in EPC-Compact:

Key(s)	Name	Function
	<b>Function keys</b>	The function keys  to  correspond to the keys or key combinations specified in the submenu of the menu bar. see Section "2.3.1 Menu Bar".
	<b>Tab key</b>	<ul style="list-style-type: none"> <li>Opens the "World Manufacturer Code" submenu in the EPC initial screen.  see Section "4.1 World Manufacturer Code".</li> <li>Moves the selection between the action buttons in pop-up menus.  see Section "2.7 Pop-Up Menus".</li> </ul>
	<b>Backspace key</b>	Deletes the last character in input fields. see Section "2.5.2 Input Fields".
 or 	<b>Return</b> or <b>Enter</b>	<ul style="list-style-type: none"> <li>Confirms entries in input fields.</li> <li>Returns to screens which have a higher position in the hierarchy (e. g. returns from the sub-group selection list to the group selection list).</li> <li>Closes submenus.  see Section "2.6 Submenus".</li> </ul>
	<b>Home</b>	<ul style="list-style-type: none"> <li>Opens a submenu in a multi-page parts information screen. This enables you to call up a particular page by entering a page number.  see Section "17.1 Parts Information for Standard Illustrated Pages".</li> <li>Opens the "LIST MENU" in the "SELECTED PARTS LIST" screen.  see Section "18.1 List Menu".</li> </ul>
 +    	<b>Shift key</b> + <b>Cursor keys</b>	The key combinations  and , , ,  enable you to move in the direction of the cursor between the submenus.  see Section "2.6 Submenus".
	<b>Insert</b>	<ul style="list-style-type: none"> <li>Activates the selection * in selection lists with multiple selection (e. g. parts information).  see Section "2.5.8 Selection Lists with Multiple Selections".</li> <li>Activates selected entries in selection lists with individual selection.  see Section "2.5.7 Selection Lists with Individual Selections".</li> </ul>

	<b>Delete</b>	Deactivates the selection * in selection lists with multiple selection (e. g. parts information).  see Section " <a href="#">2.5.8 Selection Lists with Multiple Selections</a> ".
	<b>Cursor keys</b>	<ul style="list-style-type: none"><li>• Moves the selection bar in selection lists up or down.</li><li>• Moves the enlarged screen up or down.  see Section "<a href="#">16.1 Enlarging Illustrated Pages</a>".</li><li>• Moves the selection between the action buttons in pop-up menus.  see Section "<a href="#">2.7 Pop-Up Menu</a>".</li></ul>
	<b>Cursor keys</b>	<ul style="list-style-type: none"><li>• Enable you to scroll between illustrated pages.</li><li>• Scroll in multi-page selection lists.</li><li>• Move the enlarged screen to the left or to the right.  see Section "<a href="#">16.1 Enlarging Illustrated Pages</a>".</li><li>• Move the selection between the action buttons in pop-up menus.  see Section "<a href="#">2.7 Pop-Up Menu</a>".</li></ul>
	<b>Page up</b>	<ul style="list-style-type: none"><li>• Moves down a page in multi-page selection lists.</li><li>• Moves to the next illustrated page.</li></ul>
	<b>Page down</b>	<ul style="list-style-type: none"><li>• Moves up a page in multi-page selection lists.</li><li>• Returns to the previous illustrated page.</li></ul>
	<b>Print</b>	Creates a 1:1 printout of the contents of the screen (hard copy).  see Section " <a href="#">21 Printing</a> ".
	<b>Alt key</b> + <b>Tab key</b>	You can switch between active programs using the key combination  +  (tab) and without interrupting the current program.  When you switch between programs, the programs remain active. The screen settings and selections stay the same.





## 2.3 Screen Areas

The EPC-Compact screen is divided into the following areas:

- Windows header
- Menu bar
- Toolbar
- Information area
- Work area
- EPC message line



- ① **Windows header**      Contains the program name “EPC-Compact”. The options here are the same as those in the standard Windows environment.
- ② **Menu bar**              The menu bar contains the main menus:
- File
  - Terminal
  - Goto
  - Find
  - Information
  - Part Info
  - Image
  - Review List
  - Help
- A separate submenu with various menu entries is assigned to each main menu.  
 📖 see Section "2.3.1 Menu Bar".
- ③ **Toolbar**                 Contains action buttons (e. g. Print, Zoom...) which you can use to trigger functions.  
 📖 see Section "2.4 Toolbar".







- 
- ④ **Information area**      Contains information fields which vary, depending on the contents of the work area. You cannot make any entries here.  see Section "[2.4.1 Information Area](#)".
  - ⑤ **Work area**      This is where you interact with the EPC (e. g. inputs, selections, displays, requests, ...).
    - ①  The individual control elements are displayed in the work area, in accordance with the screen.  see Section "[2.5 Control Elements](#)".
  - ⑥ **EPC message line**      Displays system messages (e. g. "No datacard available").  
 see Section "[2.4.2 EPC Message Line](#)".









































### 2.3.1 Menu Bar

The menu bar contains submenus with commands that trigger functions or call up submenus, in accordance with the contents of the work area. The menu bar and function bar contain the same functions.

-  Some of the commands in the submenus of the menu bar may not always be available. This depends on the screen currently displayed.



Menu	Submenu	Function key/Key combination	Meaning / Function
File	Configuration		Calls up the "DBCP Configuration" screen in which you can define the basic EPC settings (e. g. background color, ...).  see Section "23 DBCP Configuration".
	Print	 + P	Calls up the "Print" submenu. Usually, only the contents displayed on the screen are formatted and printed out, with the exception of the "Data card" and "SELECTED PART LIST" screens.  see Section "21 Printing".
	Print Window	 + W	Calls up the "Print" submenu. Only the contents displayed in the EPC window are printed out.  see Section "21 Printing".
	Print Screen	Prt Scrn	Calls up the "Print" submenu. Creates a 1:1 printout of the screen contents (hard copy).  see Section "21 Printing".
	Print Setup		Calls up the "Print" submenu and allows you to define the print setup settings as standard in Windows.  see Section "21 Printing".



Menu	Submenu	Function key/Key combination	Meaning / Function
	<b>Exit</b>	 + 	Calls up the "SYSX Menu" which displays a confirmation prompt before you exit the EPC.  see Section " <a href="#">22 SYSX Menu</a> ".
<b>Terminal</b>	<b>Inventory Ctrl+F3</b>	 + 	No function.
<b>Goto</b>	<b>Application Index F2</b>		Calls up the "Application Index" submenu.  see Section " <a href="#">24 Application Index</a> ".
	<b>Chassis F3</b>		Calls up the EPC initial screen.  see Section " <a href="#">4 EPC Initial Screen</a> ".
	<b>Group Index F4</b>		Calls up the group index.  see Section " <a href="#">11 Standard Group Index</a> ".
	<b>Sub-group Index F5</b>		Calls up the sub-group index.  see Section " <a href="#">15 Standard Sub-Group Index</a> ".
	<b>SA Index F9</b>		Calls up the SA index.  see Section " <a href="#">13 SA Index (Special Versions Index)</a> ".
	<b>BM/SA F8</b>		Switches between <ul style="list-style-type: none"> <li>– BM = Standard parts catalogue</li> <li>– SA = SA catalogue.</li> </ul>
<b>Find</b>	<b>Find SA F10</b>		Calls up the "Find SA" submenu.  see Section " <a href="#">9 Finding SAs</a> ".
<b>Information</b>	<b>Model Info Ctrl+F8</b>	 + 	Calls up the "Information Page" submenu.  see Section " <a href="#">8 Information Page</a> ".
	<b>Data Filter F7</b>		Calls up the "Filter Menu" of the data filter.  see Section " <a href="#">10 Filter Menu</a> ".
	<b>Data Card Ctrl+F6</b>	 + 	Calls up the "data card".  This function is only possible after you have entered a valid vehicle ID number.  see Section " <a href="#">7 Data Card</a> ".
<b>Part Info</b>	<b>All records F6</b>		Opens the parts information screen and copies <b>all</b> illustrated and non-illustrated part items from the selected illustrated page.  This function is only possible in the illustrated page.  see Section " <a href="#">16.3 All records - F6</a> ".  see Section " <a href="#">16 Illustrated Page</a> ".  see Section " <a href="#">17 Parts Information/SA Parts Information</a> ".
	<b>Footnotes Ctrl+F2</b>	 + 	Calls up the "Footnotes" submenu.  see Section " <a href="#">17.3 Footnotes</a> ".
<b>Image</b>	<b>Image Text F12</b>		Shows or hides the illustrated pages in the parts information.  This function is only possible in the parts information or illustrated page.  see Section " <a href="#">20 Displaying Images/Text</a> ".
	<b>Zoom Ctrl+F1</b>	 + 	Activates/deactivates the enlargement (zoom) function in illustrated pages.  see Section " <a href="#">16.1 Enlarging Illustrated Pages</a> ".

Menu	Submenu	Function key/Key combination	Meaning / Function
Review List	View List	Ctrl + F4	Calls up the "SELECTED PARTS LIST". 📖 see Section "18 Selected Parts List".
	Add Parts	Ctrl + F9	<ul style="list-style-type: none"> <li>• Calls up the "Add Part Number" submenu. 📖 see Section "19 Add". 📖 see Section "19.1 Add Part Number".</li> <li>• Calls up the "ES CODE INPUT" submenu from the parts information. 📖 see Section "19.2 ES Code Input (only possible in the parts information)".</li> </ul>
	List Menu	Pos 1	Calls up the "LIST MENU" for changing the review list (e. g. adding a parts number, changing a designation, ...). 📖 see Section "18.1 List Menu".
	List Utils	Ctrl + F7	Calls up the "LIST UTILITIES" submenu for administrating the review list (e. g. save current list, copy a list ...). 📖 see Section "18.2 Util (List Utilities)".
Help	Help Screen	F1	Calls up the "DB EPC HELP" with help texts for the screen concerned. 📖 see Section "2.8 Help".
	Fkey map		Opens a submenu for choosing the desired function.

## 2.4 Toolbar

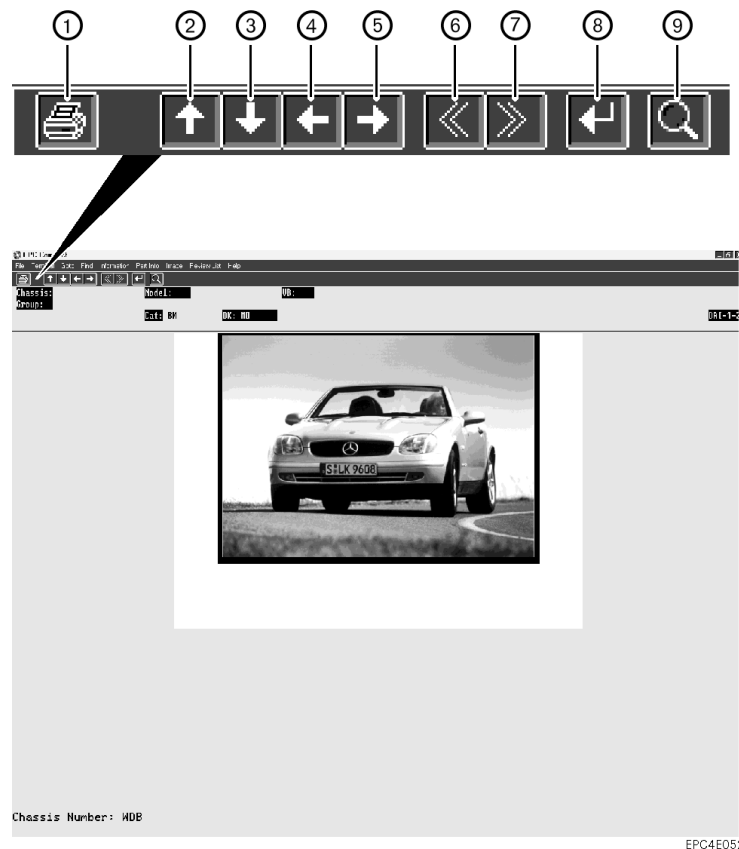
You can only operate the toolbar with the mouse. The toolbar contains action buttons for triggering functions. The buttons displayed vary depending on the contents of the work area.



- ① **Print**
  - Calls up the “Print” submenu for setting the print options.
  -  see Section "21 Printing".
- ② **Cursor key up**
  - Moves the selection bar up in a selection list.
  - Moves the enlarged screen up.
- ③ **Cursor key down**
  - Moves the selection bar down in a selection list.
  - Moves the enlarged screen down.
- ④ **Cursor key left**
  - Scrolls within selection lists.
  - Moves the enlarged screen to the left.
- ⑤ **Cursor key right**
  - Scrolls within selection lists.
  - Moves the enlarged screen to the right.
- ⑥ **Page up**
  - Moves down a page.
  - Moves to the next illustrated page.
- ⑦ **Page down**
  - Moves up a page.
  - Returns to the previous illustrated page.
- ⑧ **Return**
  - Confirms entries in input fields.
  - Returns to screens which have a higher position in the hierarchy (e. g. returns from the sub-group selection list to the group selection list).
  - Closes submenus.
- ⑨ **Zoom**
  - Activates/deactivates the enlargement (zoom) function in illustrated pages.
  -  see Section "16 Illustrated Page"

## 2.4.1 Information Area

The "information area" contains information on the criteria chosen by the user for determining a specific part.

Chassis: WDB309425 10 867346 Model: 309.425 10 867346 VB: L 508 DG  
 Group: 47 - FUEL SYSTEM SA: 15773/13 TANK FILLER CAP LOCKABLE  
 Class: SA AVAIL Cat: SA DK: CODE/SA Agg: CHASSIS Filter: STD DAI-1-2 ①

Collat	Q1 - Part Number	Q2 - Part Number	Description	Part Dates	Ver	Qty
001	A 000 471 16 30	A 100 473 01 05	FILLER CAP REPLACED BY: A 000 471 71 30			
001	A 000 471 71 30	A 100 473 01 05	FILLER CAP W/TH 2 KEYS		407	002
004	A 000 471 11 80		GASKET REPLACED BY: A 000 471 10 80			
004	A 000 471 10 80		GASKET		002	002
----	A 000 750 06 06		KEY		407	002
					001	
----	A 601 471 00 93		KEY BLANK		002	002

- Chassis** Depending on input/selection, displays
- the selected model (6-character),
  - the selected vehicle ID number (17-character).
- Model** Depending on input/selection, displays
- the selected type,
  - the selected model,
  - the selected vehicle ID number,
  - the selected aggregate ID number.
- VB** Sales designation.  
Displays the chassis, engine, or transmission sales designation, depending on the selected engine.
- Group** Displays the selected group index together with its designation.
- SA** Special version.  
Displays the chosen SA number, stroke, and designation.
- Class** No function.
- Cat.** Displays the selected catalogue.
- BM** Model catalogue
- SA** SA catalogue
- DK** Displays the data card status.
- NO** No data card available.
- GR/SA** Data card sorted according to group/SA.
- CODE/SA** Data card sorted according to CODE/SA.
- CODE** SA not taken into account. All technically possible SAs are displayed.
- ① The customer has to provide information on all SAs that are actually installed.  
The codes have to be evaluated manually using the CODE book.

<b>Agg</b>	<b>Chassis</b>	Chassis Catalogue
	<b>Agg: M</b>	Aggregate Catalogue: Engine
	<b>Agg: GM</b>	Aggregate Catalogue: Manual Transmission
	<b>Agg: GA</b>	Aggregate Catalogue: Automatic Transmission
	<b>Agg: P</b>	Aggregate Catalogue: Platform
	<b>Agg: FH</b>	Aggregate Catalogue: Cab/Body
	<b>Agg: LG</b>	Aggregate Catalogue: Steering
	<b>Agg: V1</b>	Aggregate Catalogue: Front Axle 1
	<b>Agg: V2</b>	Aggregate Catalogue: Front Axle 2
	<b>Agg: H1</b>	Aggregate Catalogue: Rear Axle 1
	<b>Agg: H2</b>	Aggregate Catalogue: Rear Axle 2
	<b>Agg: VG</b>	Aggregate Catalogue: Transfer Case
	<b>Agg: FG</b>	Aggregate Catalogue: Chassis
<b>Filter</b>		Description of the status of the system filter settings.  see Section " <a href="#">10 Filter Menu</a> ". Possible entries:
	<b>STD</b>	DEFAULT FILTER LEVELS.
	<b>MOD</b>	Filter setting was changed.
	<b>OFF</b>	NO FILTERING.
<b>SA AVAIL</b>		SA information (extras) is available for the selection made.
① <b>Workstation name</b>		Name of the workstation.

## 2.4.2 EPC Message Line

System messages are displayed in the "EPC message line".

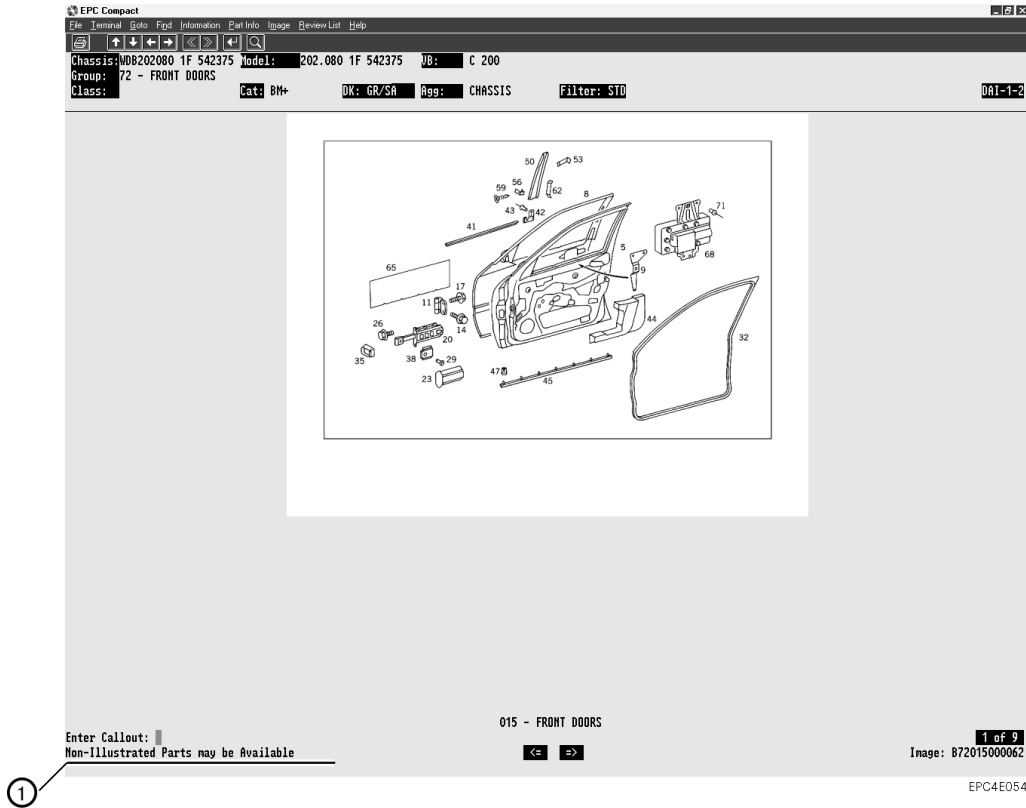

### ① EPC message line

Displays system messages.

#### Non-Illustrated Parts may be Available

Indicates that not all parts are displayed on the illustrated page.

 With function "F6 All", you can copy all parts to the parts information, including the non-illustrated parts.

 see Section "16.3 All records - F6".

 see Section "2.3.1 Menu Bar".

#### No datacard available

This message appears after you have entered a 14-character vehicle ID number

- whose data card is not stored in the EPC.  
In this case, the 6-character model type is evaluated.
- in conjunction with an incorrect world manufacturer code.  
You must choose the correct world manufacturer code.  
 see Section "4.1 World Manufacturer Code".

#### No matching parts are available

This message appears if no illustrated page is available and if the "All records - F6" function called up no parts information.

In this case, the parts are contained in the standard parts catalogue.

You can go directly to the standard parts catalogue using the following functions:

- Menu bar "Goto/BM/SA F8"
- With 
- With the right mouse button

## 2.5 Control Elements

You operate the control elements by:

- Means of the keyboard
- Selecting the elements using the **left** mouse button

In the following section, the control elements are described in detail according to:

- Properties
- Mouse and keyboard control
- Tips, important additional information

### 2.5.1 Information Field

Displays the information selected by the user (vehicle-specific, information-specific).

-  Inputs and selections are **not** possible.

**Chassis: WDB202080 1F 542375**

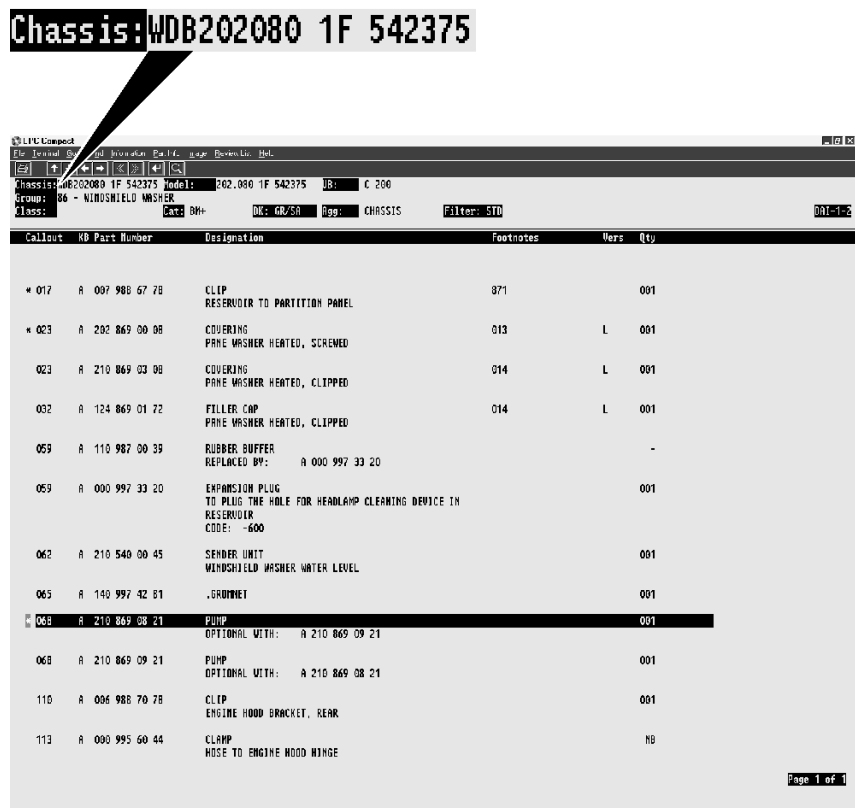

Callout	RB	Part Number	Designation	Footnotes	Vers	Qty
* 017	A	097 988 67 78	CLIP RESERVOIR TO PARTITION PANEL	371		001
* 023	A	292 869 00 08	COVERING PANE WASHER HEATED, SCREENED	013	L	001
023	A	210 869 03 08	COVERING PANE WASHER HEATED, CLIPPED	014	L	001
032	A	124 869 01 72	FILLER CAP PANE WASHER HEATED, CLIPPED	014	L	001
059	A	110 987 00 39	RUBBER BUFFER REPLACED BY: A 000 997 33 20			-
059	A	000 997 33 20	EXPANSION PLUG TO PLUG THE HOLE FOR HEADLAMP CLEANING DEVICE IN RESERVOIR CODE: -600			001
062	A	210 540 00 45	SENDER UNIT WINDSHIELD WASHER WATER LEVEL			001
065	A	140 997 42 81	.GRUNNET			001
068	A	210 869 08 21	PUMP OPTIONAL WITH: A 210 869 09 21			001
068	A	210 869 09 21	PUMP OPTIONAL WITH: A 210 869 08 21			001
110	A	098 988 70 78	CLIP ENGINE HOOD BRACKET, REAR			001
113	A	000 995 60 44	CLAMP HOSE TO ENGINE HOOD WINGE			NB

Page 1 of 1

EPC4E056

## 2.5.2 Input Fields

For entering data. The input field generally contains a blinking cursor. You confirm your entries with .

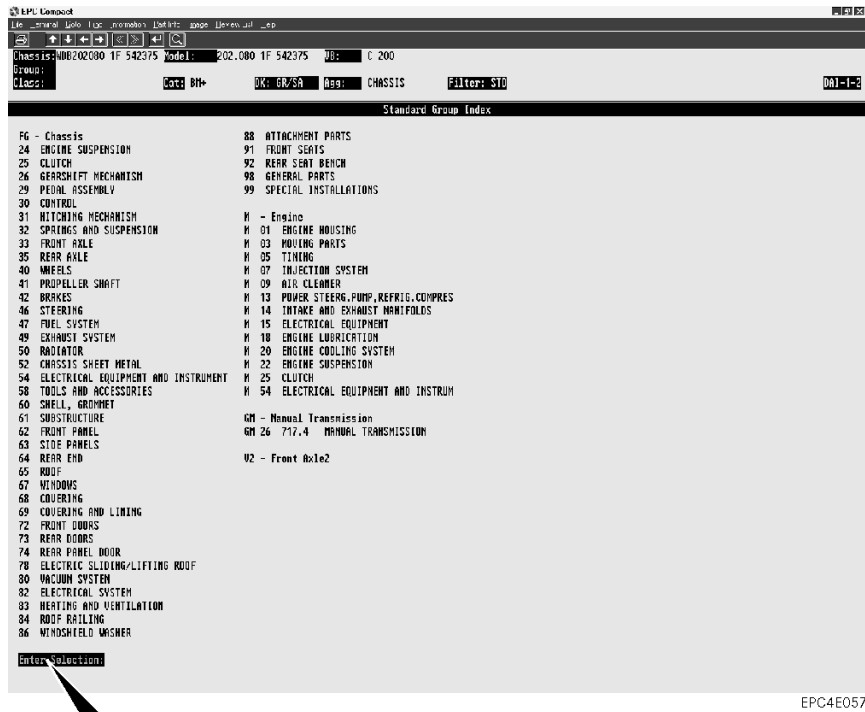

- Enter data.
- Confirm with the right mouse button  
or
- Click the "Return" action button in the toolbar.  see Section "2.4 Toolbar".

e. g. 24



- Enter data.
- Confirm.
- Deletes the last character (for correction purposes).

### 2.5.3 Action Button

The action button calls up a submenu or triggers an action.

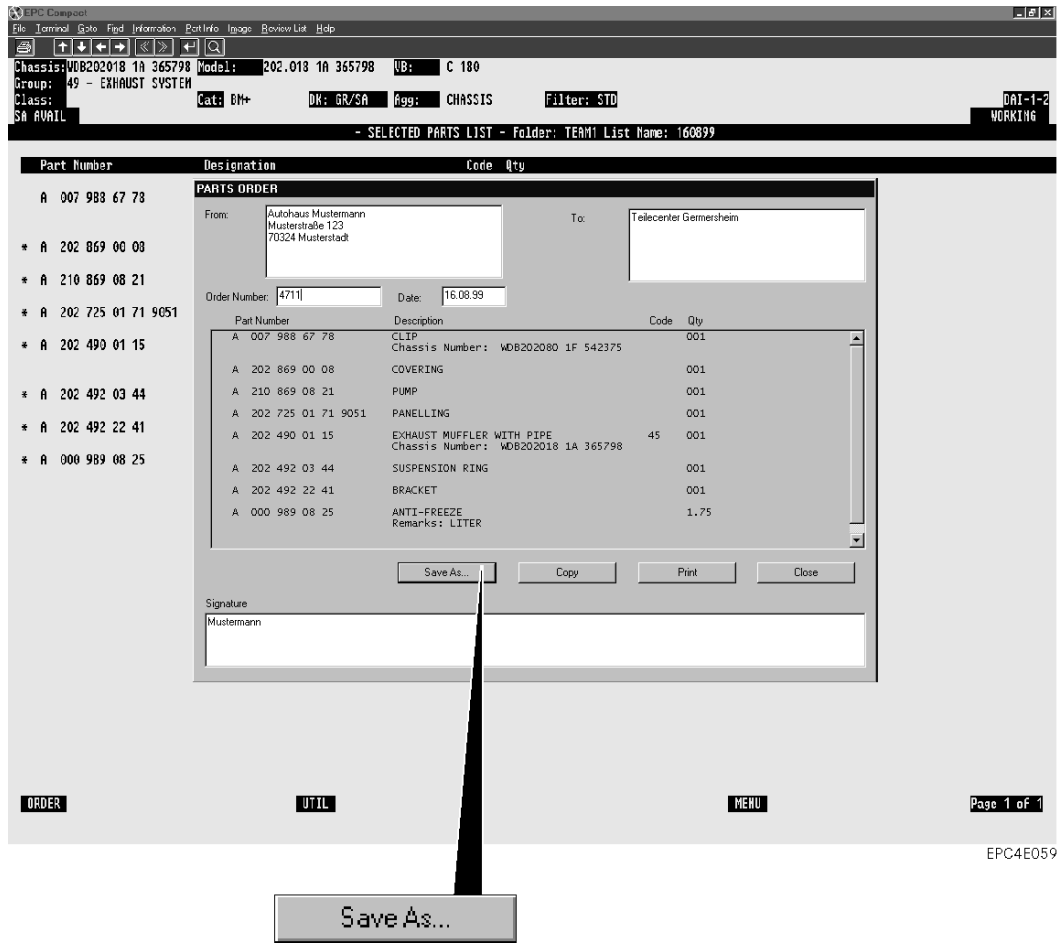

The screenshot shows the EPC Compact software interface. At the top, there is a menu bar with options like File, Terminal, Gate, Find, Information, PartInfo, Image, Review List, and Help. Below the menu bar, there is a status bar with various fields: Chassis: W08202018 1A 365798, Model: 202.018 1A 365798, UB: C 180, Group: 49 - EXHAUST SYSTEM, Cat: BM+, DK: GR/SA, Agg: CHASSIS, Filter: STD, and DAI-1-2 WORKING. The main area displays a 'SELECTED PARTS LIST' with columns for Part Number, Designation, Code, and Qty. A 'PARTS ORDER' dialog box is open, showing a list of parts to be ordered. The 'Save As...' button is highlighted, and a callout box below it is labeled 'Save As...'.

Part Number	Designation	Code	Qty
A 007 988 67 78	CLIP		001
* A 202 869 00 08	COVERING		001
* A 210 869 08 21	PUMP		001
* A 202 725 01 71 9051	PANELLING		001
* A 202 490 01 15	EXHAUST MUFFLER WITH PIPE	45	001
* A 202 492 03 44	SUSPENSION RING		001
* A 202 492 22 41	BRACKET		001
* A 000 989 08 25	ANTI-FREEZE		1.75



- Click the action button with the **left** mouse button.
- ⇒ A submenu is called or an action triggered.

## 2.5.4 Page Arrow

The **page arrow** indicates that further pages are available in the current screen. The page arrow enables you to scroll one page forwards or backwards.

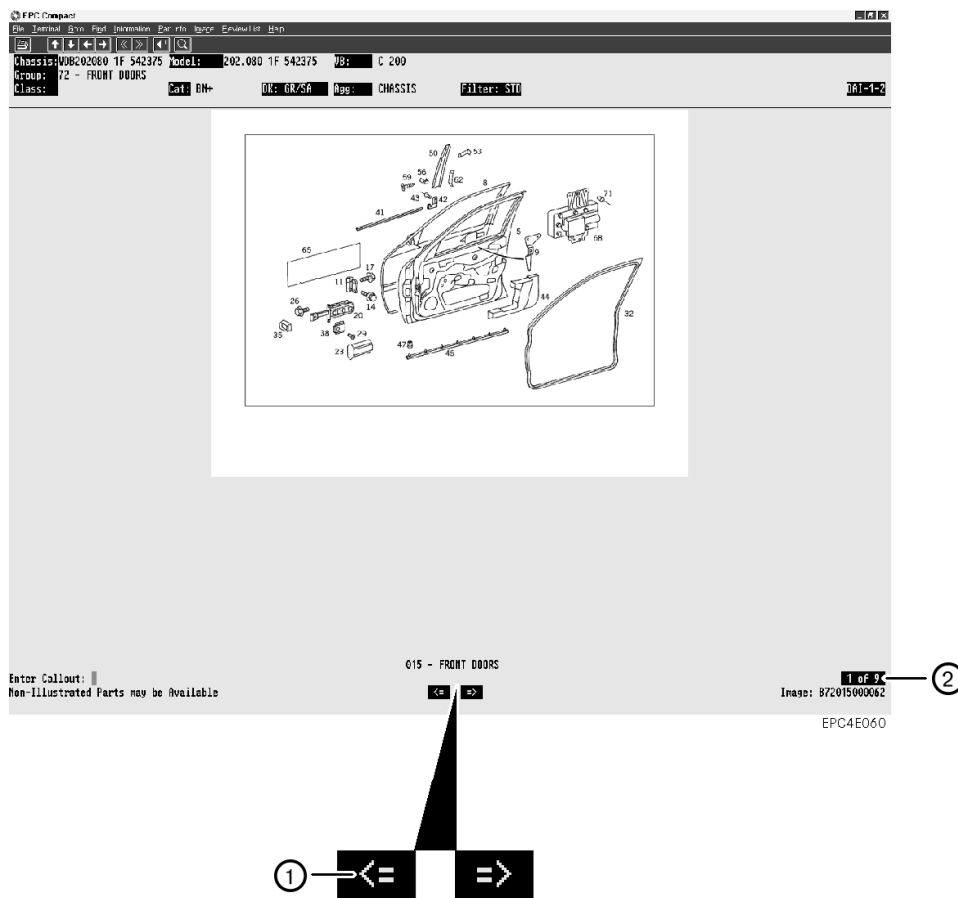

- ① **Page arrow**                      Scrolls one page forwards or backwards.
- ② **Information field**                An information field is generally displayed together with the page arrow. This field shows the page currently displayed and the total number of pages.

### Scrolling by page



- Click the page arrow with the **left** mouse button.
- ⇒ You scroll one page forwards or backwards.

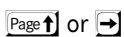

- Scrolls one page forwards.



- Scrolls one page backwards.

## 2.5.5 Selection List

Contains one or more selection options in a table. Individual or multiple selections may be available, depending on the function.

There are three types of selection list:

- Selection lists with input fields
- Selection lists for individual selections
- Selection lists for multiple selections

## 2.5.6 Selection Lists with Input Fields

You can only make individual selections in selection lists with input fields.

To activate an entry in the list:

- Select it with the left mouse button.
- Enter the abbreviation in the input field and confirm it with .

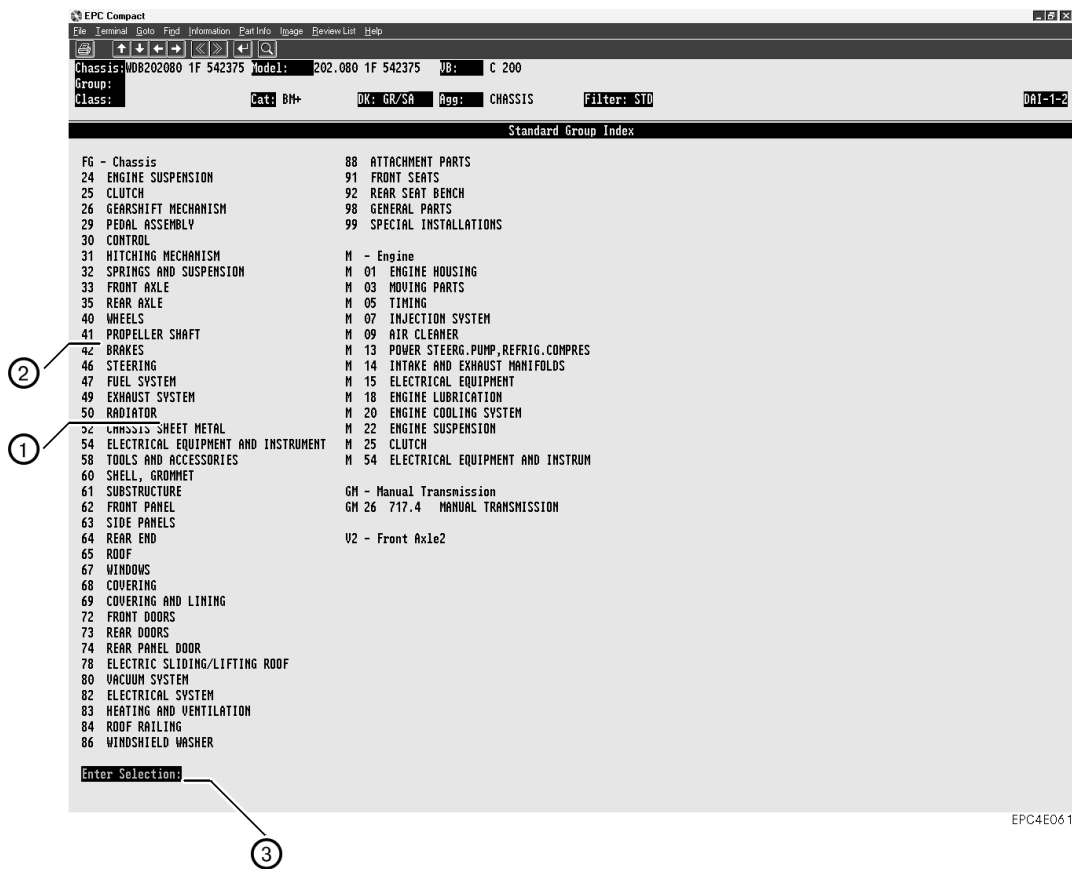

- ① **List entry** Element in a selection list. Each list entry generally has an abbreviation.
- ② **Abbreviation** You can enter the abbreviation in the input field.  
Example:
  - Group or sub-group number
  - Catalogue code (e. g. M=engine, ...)
- ③ **Input field** For entering an abbreviation that is assigned to an entry in the selection list (e. g. group or sub-group number, catalogue code, e. g. M=engine, ...).



- Select list entry with the left mouse button.
- ⇒ An action is triggered.

e. g. 25



- Enter abbreviation of the list entry in the input field.
- Confirm.
- ⇒ An action is triggered.

## 2.5.7 Selection Lists with Individual Selections

You can only make one **single selection** in the selection lists with individual selections.

You can activate a list entry by:

- Selecting it or
- Pressing **Ins**



If you press the **Return** key, you go back a screen.

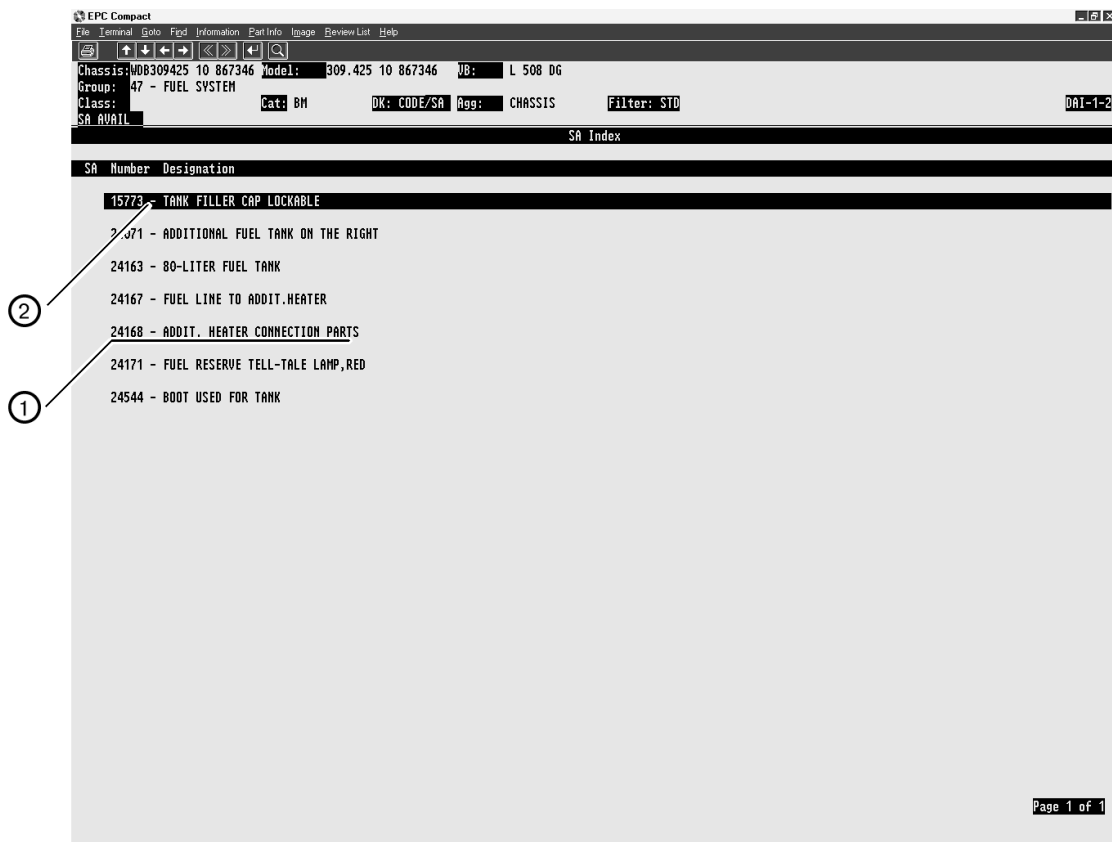

- ① **List entry** Element in a selection list.
- ② **Selection bar** The selection bar displays the list entry that is currently selected.



- Select the desired list entry with the **left** mouse button.
- ⇒ An action is triggered.



- Position the selection bar on the desired list entry.
- Confirm.
- ⇒ An action is triggered.

## 2.5.8 Selection Lists with Multiple Selections

You can make **multiple selections** in selection lists with multiple selections. A star (\*) indicates that a list entry has been selected. You can activate a list entry by selecting it or by pressing .

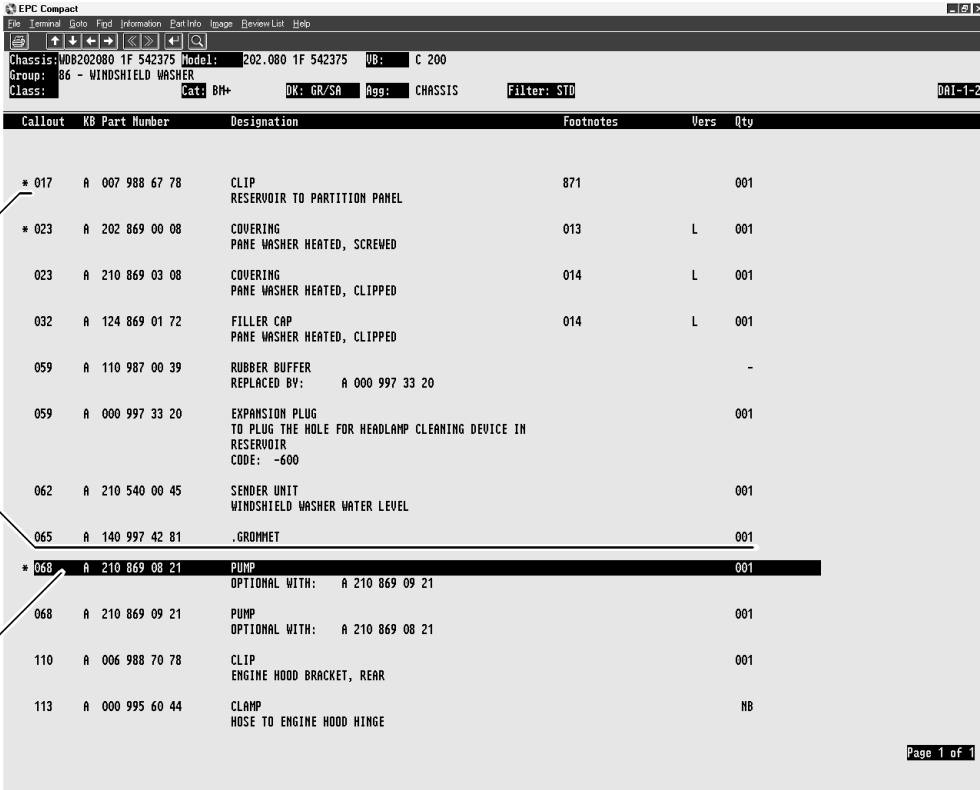

Callout	KB	Part Number	Designation	Footnotes	Vers	Qty
3	*	017	A 007 988 67 78	CLIP RESERVOIR TO PARTITION PANEL	871	001
	*	023	A 202 869 00 08	COVERING PANE WASHER HEATED, SCREWED	013	L 001
		023	A 210 869 03 08	COVERING PANE WASHER HEATED, CLIPPED	014	L 001
		032	A 124 869 01 72	FILLER CAP PANE WASHER HEATED, CLIPPED	014	L 001
		059	A 110 987 00 39	RUBBER BUFFER REPLACED BY: A 000 997 33 20		-
		059	A 000 997 33 20	EXPANSION PLUG TO PLUG THE HOLE FOR HEADLAMP CLEANING DEVICE IN RESERVOIR CODE: -600		001
1		062	A 210 540 00 45	SENDER UNIT WINDSHIELD WASHER WATER LEVEL		001
		065	A 140 997 42 81	.GROMMET		001
	*	068	A 210 869 08 21	PUMP OPTIONAL WITH: A 210 869 09 21		001
2		068	A 210 869 09 21	PUMP OPTIONAL WITH: A 210 869 08 21		001
		110	A 006 988 70 78	CLIP ENGINE HOOD BRACKET, REAR		001
		113	A 000 995 60 44	CLAMP HOSE TO ENGINE HOOD HINGE		HB

Page 1 of 1  
EPC4E063

- ① **List entry** Element in a selection list.
- ② **Selection bar** The selection bar displays the list entry that is currently selected.
- ③ **Star “\*”** Indicates list entries that have already been selected.

### Activating a list entry (\*)



- Select the desired list entry with the **left** mouse button.
- ⇒ The list entry is **activated** (a star “\*” appears in front of the list entry).



- Position selection bar on the desired list entry.
- Confirm.
- ⇒ The list entry is **activated** (a star “\*” appears in front of the list entry).

### Deactivating a list entry (no \*)



- Select the desired list entry with the **left** mouse button.
- ⇒ The list entry is **deactivated** (the star “\*” in front of the list entry is deleted).



- Position the selection bar on desired list entry.
- Confirm.
- ⇒ The list entry is **deactivated** (the star “\*” in front of the list entry is deleted).

## 2.6 Submenus

Some functions / actions call up submenus that contain additional functions. The submenu is displayed over part of the current screen. As long as the submenu is open, you cannot edit the visible part of the work area behind this submenu.

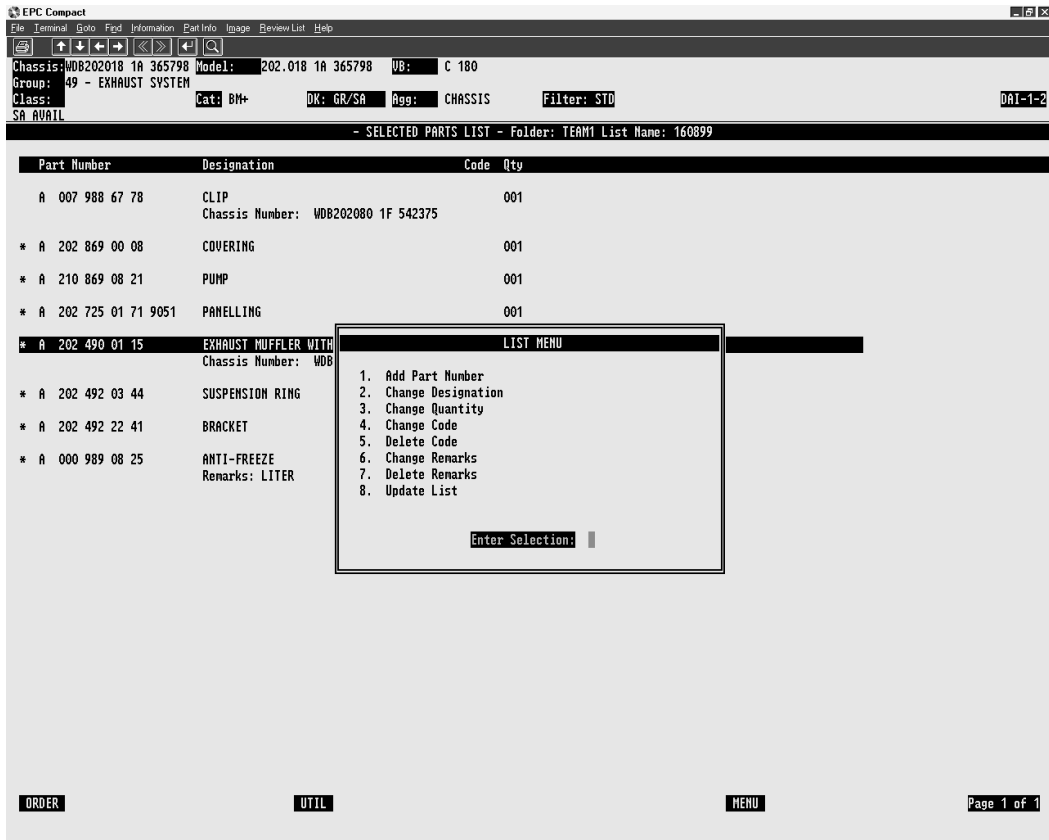

EPC4E093

### Submenu

The submenus contain action buttons, selection lists, input fields, and sometimes other control elements.

### Closing a submenu



- Click the **right** mouse button.
- ⇒ The submenu is closed.



- ⇒ The submenu is closed.

### Moving a submenu



- ⇒ The submenu moves in the appropriate direction.

## 2.7 Pop-Up Menus

Some actions call up pop-up menus. These menus are generally system messages, which you may have to acknowledge. The pop-up menu is displayed over part of the work area. As long as the pop-up menu is open, you cannot edit the visible part of the work area behind this pop-up menu.

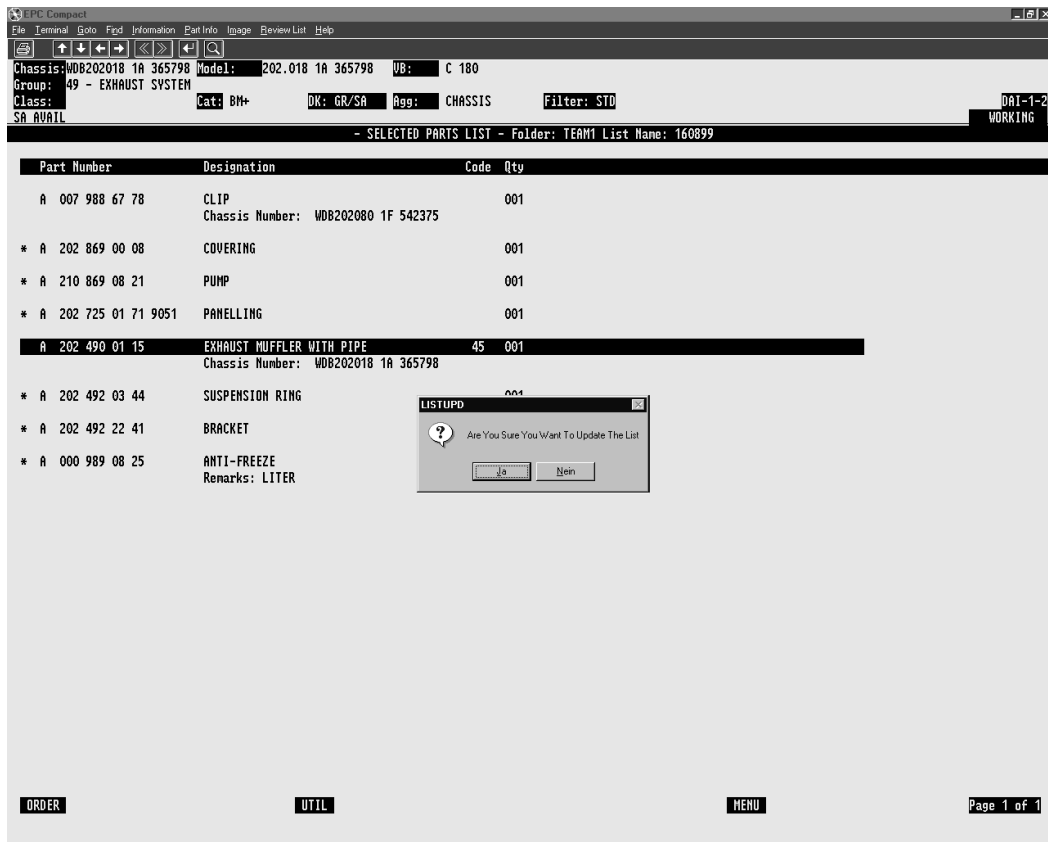

### Pop-up Menu

Pop-up menus contain information that explains why they have been displayed. They may contain decisions, which you have to acknowledge.

## 2.8 Help

Depending on where you are in the EPC, you can use the help function to call up a help text with explanations on every topic. The help text is displayed in a submenu.  see Section "2.6 Submenus".



You can call up help from any screen in the EPC.

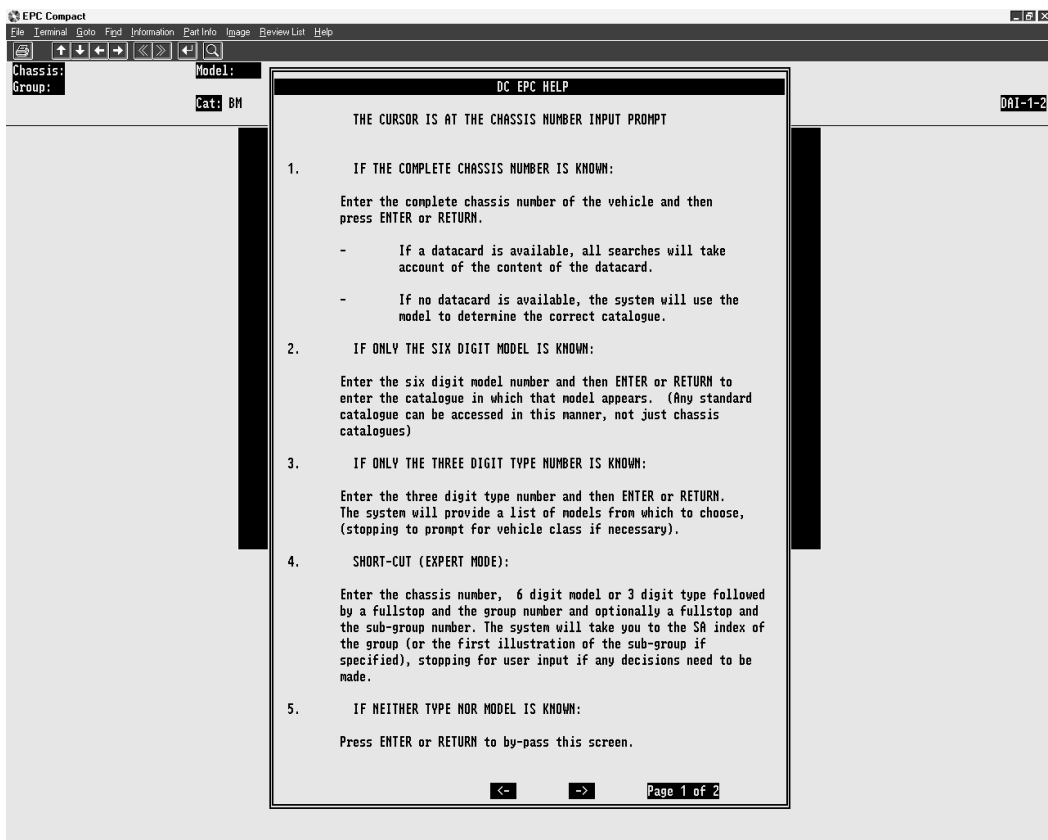

EPC4E066



- Choose “Help” in the menu bar with the left mouse button, and then "HELP Screen F1".
- or
- Click “F1 Help” in the function bar (if the function bar is active).
- ⇒ The Help function is displayed.



- ⇒ The Help function is displayed.

### 3 EPC Access Paths

You always access EPC-Compact and the various catalogues available via the EPC initial screen. The data you enter in the EPC initial screen determines the access path you take.

A distinction is made between the following access paths:

- Vehicle ID number with data card stored in the system.  
⇒ Recommended standard access path.
- Vehicle ID number without data card stored in the system.
- Model no. (4, 5 or 6-character).
- Type no. (3-character).
- Fast access (vehicle ID number, model no. or type no. together with a group or group/sub-group number that is valid for the selection.)



Depending on the access path you have selected, you may be able to skip some of the levels shown in the following diagram, in other words, you do not have to make any entries here.

The diagram only represents a very simplified overview of the possible access paths in the EPC. The following sections cover the options and links in more detail.

3.1 EPC Access Paths in Conjunction with the Vehicle ID Number

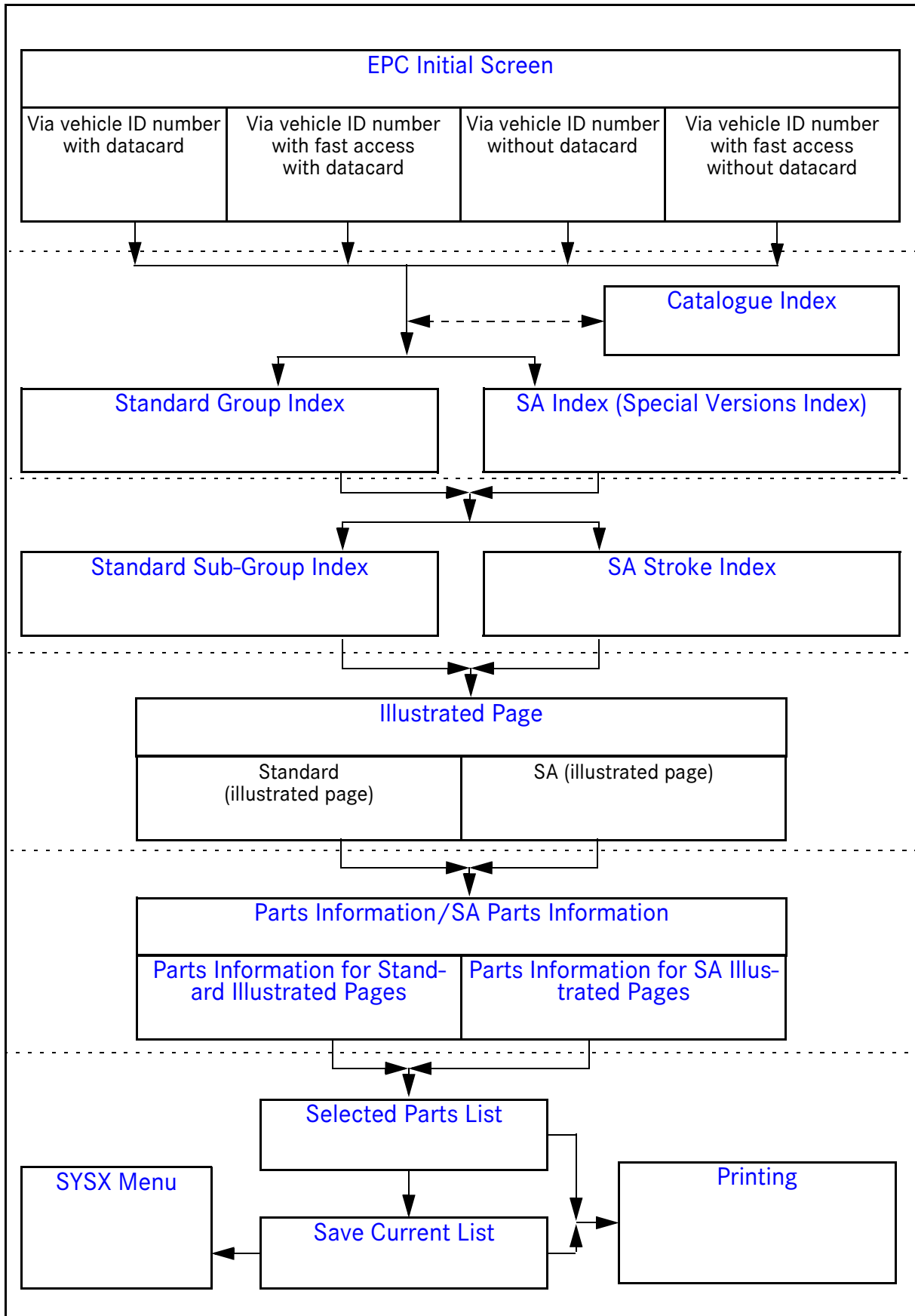

3.2 EPC Access Paths in Conjunction with Type or Model

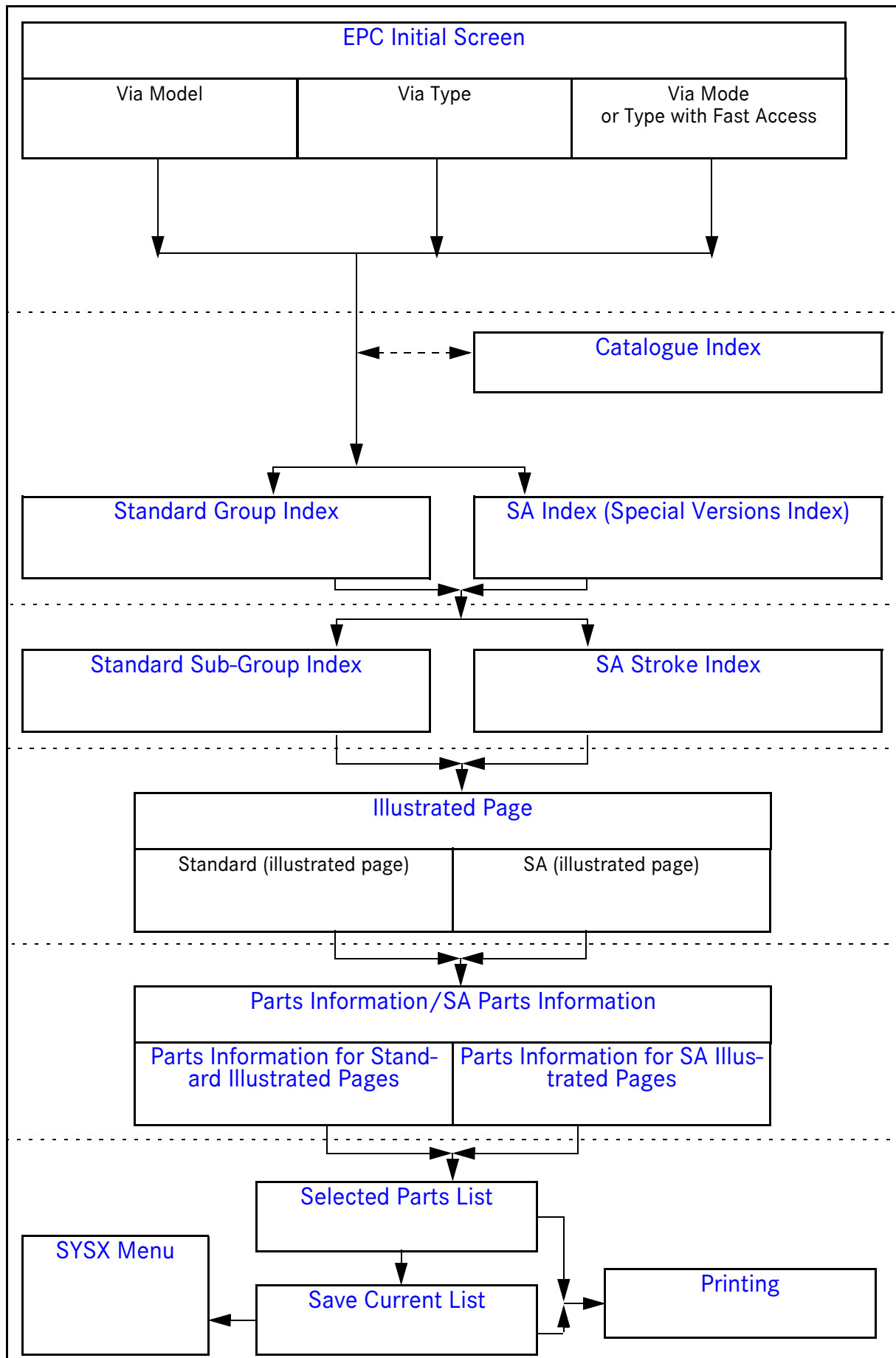

## 4 EPC Initial Screen

In the EPC initial screen, you can choose an access path to the appropriate catalogue by **entering** the vehicle ID number or model number, for example. Depending on the entry, the EPC determines the models, and possibly group/sub-group/SA. If more than one option is available in a particular screen, an additional screen will ask you to make a selection or enter further information.

You can access the individual catalogues by entering the following criteria:

- Vehicle ID no.
- Model no. (4, 5 or 6-character)
- Type no.
- Via fast access (vehicle ID no., model no. or type no. together with a group or group/sub-group no. that is valid for the selection).

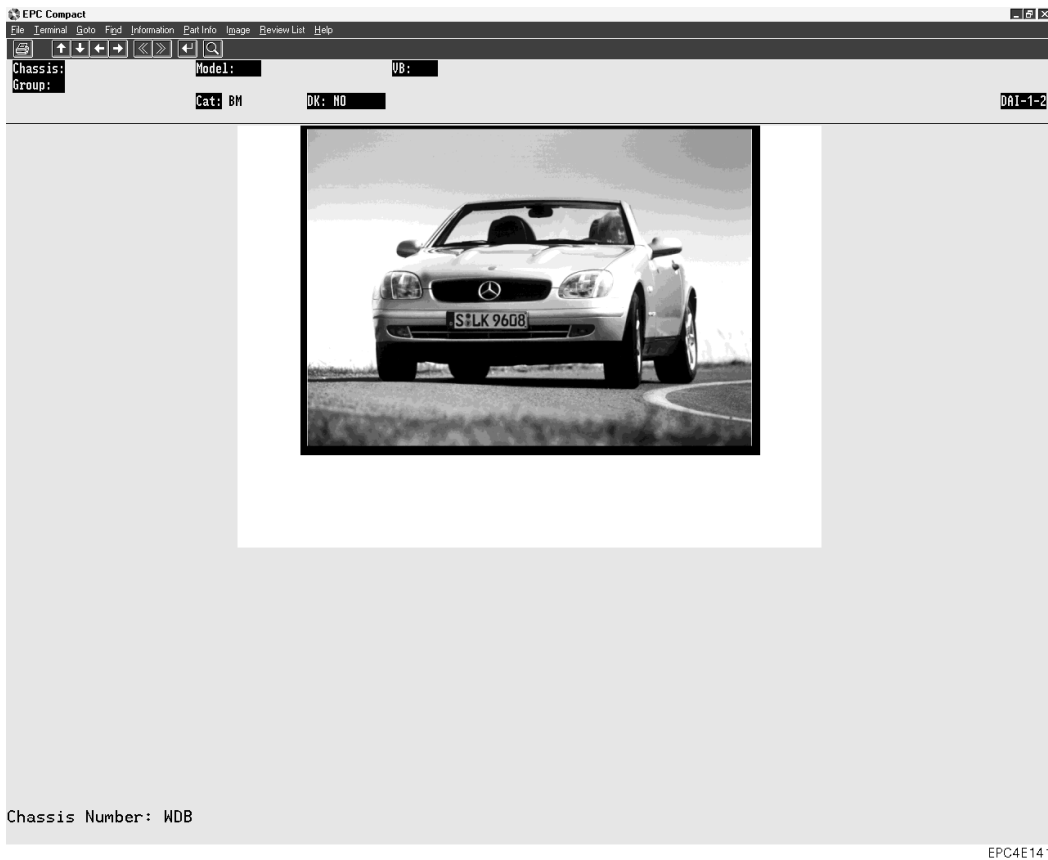

Before entering a 14-character vehicle ID number, you have to choose the appropriate world manufacturer code. see Section ["4.1 World Manufacturer Code"](#).

**Chassis Number** For entering the

- **Vehicle ID no.** (14-character, e. g. 2100041A000456).
  - When you enter a 14-character vehicle ID number whose data card is not stored in the EPC, only the 6-character model type is evaluated.

- **Vehicle ID no.** together **with** the **group no.** or **group/sub-group no.** (e. g. 2100041A000456.46.22).
  - ❗ You should separate the group no. or group/sub-group no. with a period. If a data card is available for the system, the models, SA used, and catalogues for the product are determined automatically. The default filter function is set automatically. Data filter, 📖 see Section "[10 Filter Menu](#)". If no data card has been stored, the message "No datacard available" appears in the EPC message line. 📖 see Section "[2.4.2 EPC Message Line](#)".
- **Model no.** (4, 5 or 6-character, e. g. 210004).
  - ❗ If the EPC cannot determine the model from the model data entered, it opens the model index. 📖 see Section "[5 Model Index](#)".
- **Model no.** (4-, 5- or 6-character) together **with** the **group no.** or **group/sub-group no.** (e. g. 210004.46.22).
  - ❗ The group number or group/sub-group number should be separated by a period.
- **Type no.** (3-character, e. g. 129).
- **Type no.** together **with** the **group no.** or **group/sub-group no.**

You should make the appropriate entry in the input field without any blanks.

When entering data for fast access, make sure you enter a period in front of the group no. and the sub-group no.!

#### WDB

Default setting of the world manufacturer code.

To change the world manufacturer code, 📖 see Section "[4.1 World Manufacturer Code](#)".

## 4.1 World Manufacturer Code

Before entering a 14-character vehicle ID number, you have to choose the appropriate world manufacturer code. The world manufacturer code (1st - 3rd characters in the 17-character vehicle ID number)

- indicates the country in which the vehicle was produced (e. g: WDB=Federal Republic of Germany, 4JG=USA,...).
- is a component of every vehicle ID number and is displayed in the vehicle ID number on the vehicle or the vehicle license and registration documents.



The world manufacturer code is only taken into consideration when you enter a vehicle ID number.

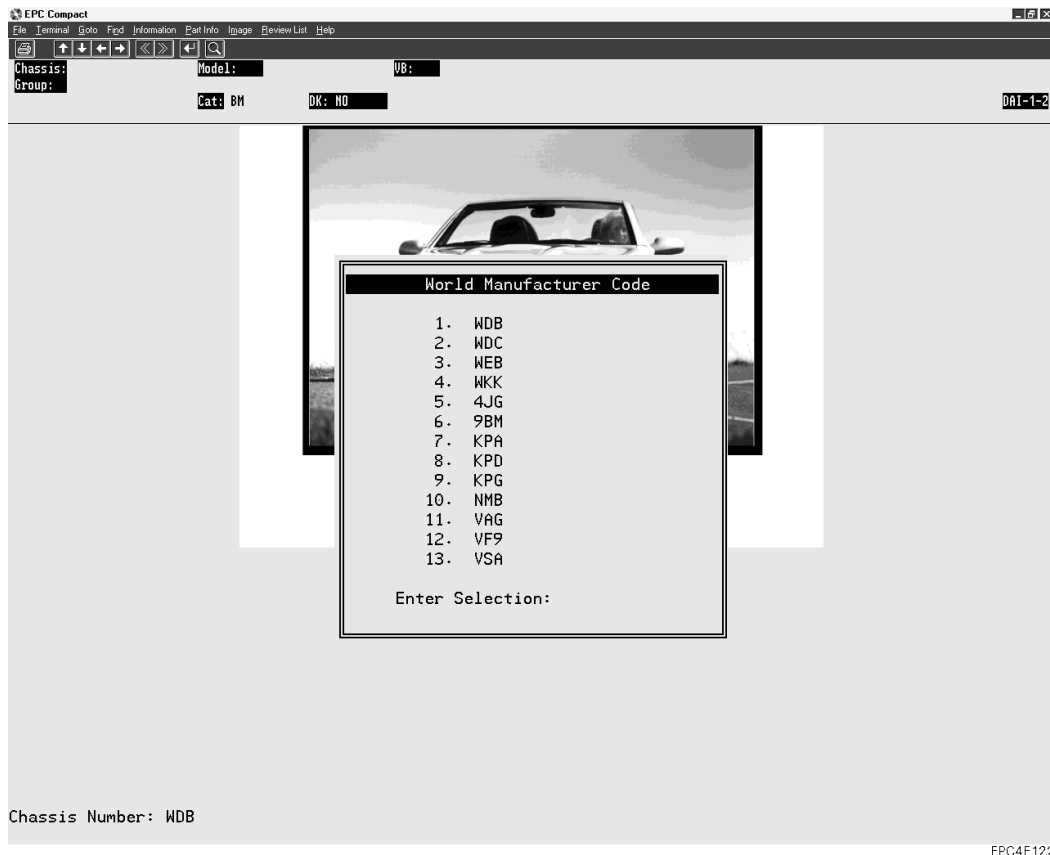

**List entry** For selecting the desired world manufacturer code.

**Enter Selection** For entering the item number of the desired list entry.



⇒ Calls up the submenu for selecting the desired world manufacturer code or entering the appropriate item number in the "Enter Selection" input field.



⇒ Goes to the world manufacturer code in the initial screen in the order listed in the submenu.

## 4.2 Warning

If you make no entries in the EPC initial screen and press the **Return** key or the right mouse button, the "Warning!" pop-up menu appears. Depending on the CD currently inserted, an information field displays the vehicle types for which you have access authorization.

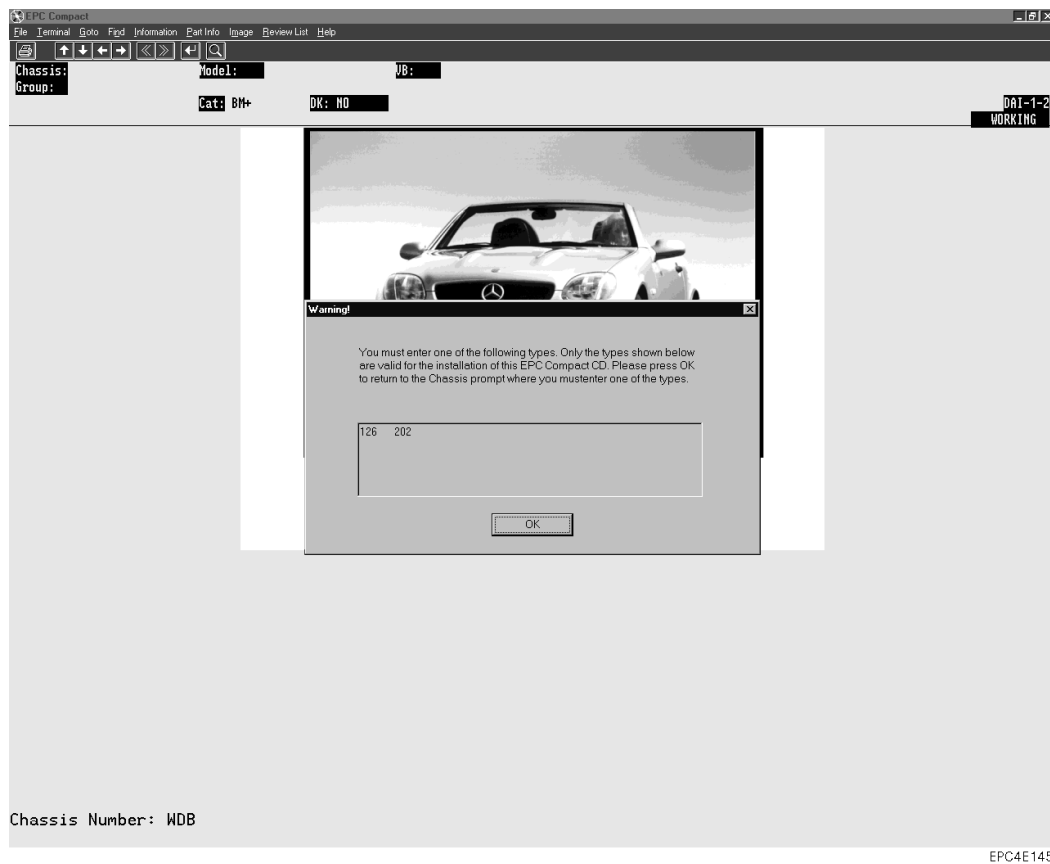

**Information field** Displays the vehicle types.

**OK** Closes the "Warning!" pop-up menu and returns to the EPC initial screen.

## 5 Model Index

The selection list of the model index lists the appropriate models, according to type, along with the corresponding sales designations and item numbers.

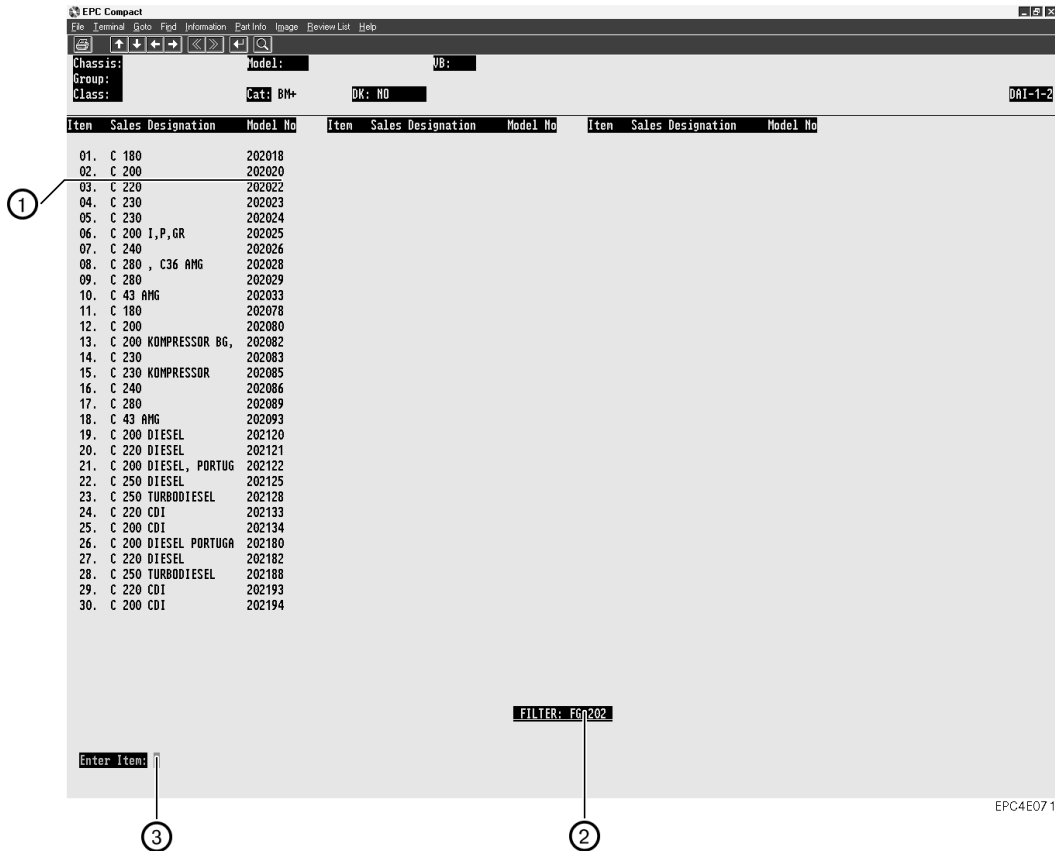

- ① **List entry** For **selecting** the appropriate model entry (e. g. 202020).
- ② **Filter** Displays the model restrictions (3 to 5-character) that were specified in the EPC initial screen.
- ③ **Enter Item** For entering the item number assigned to the model in question. (e. g. **2** for model 202020).



### Choosing a list entry

- Select the desired list entry.
- ⇒ The model is chosen.

e. g. 2



- Enter item.
- Confirm.
- ⇒ The model is chosen.



- ⇒ Deletes the last character (for correction purposes).

## 6 Catalogue Index

If several catalogues are valid for the current selection and the EPC cannot determine precisely which catalogue it should access, it opens the "Catalogue Index".

The "Catalogue Index" lists all the catalogues that are valid for the selected model. You can access the appropriate catalogue by **selecting** a list entry.

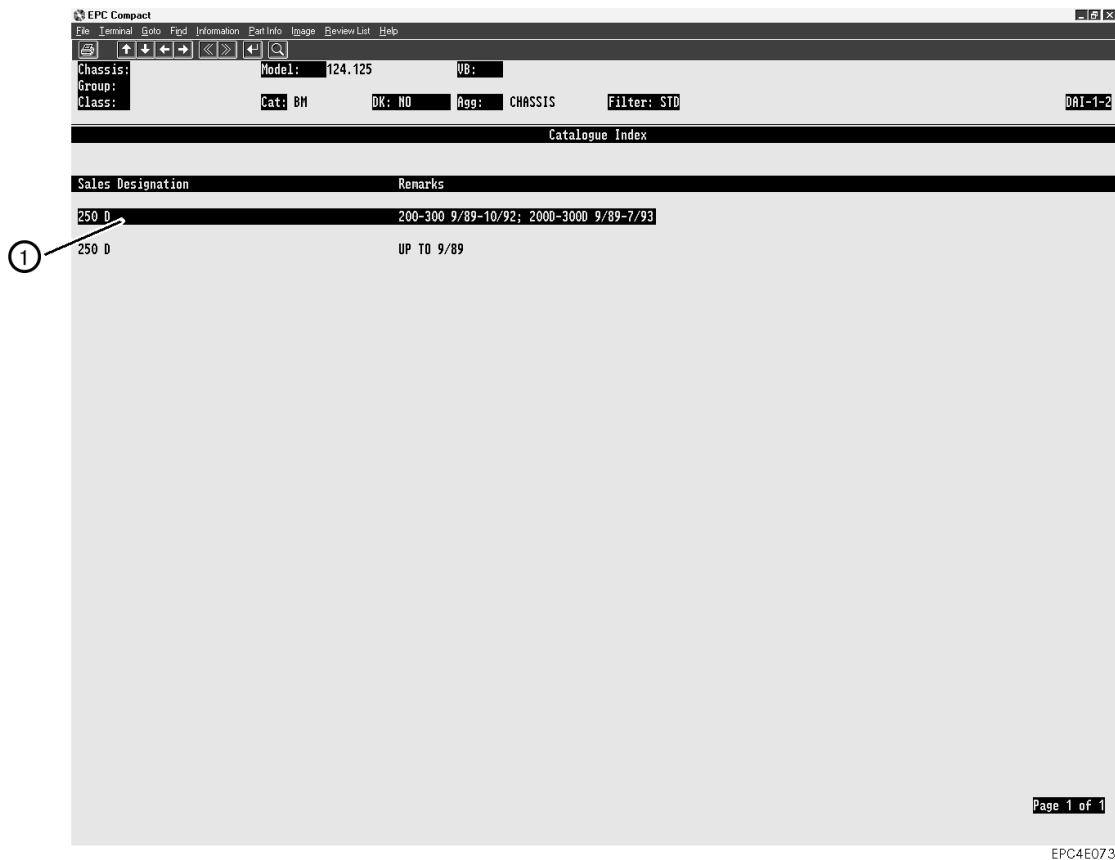

Page 1 of 1

EPC4E073

### ① List entry

For selecting the desired catalogue (e. g. to 9/89).

#### **i** Note the following

- Only individual selections are possible.
- You use the **Return** key to go back a screen.



#### Choosing a list entry

- Select the desired list entry.
- ⇒ The "Model Overview" screen opens see Section ["6.1 Model Overview"](#).
- Position the selection bar on the desired list entry.
- Confirm.
- ⇒ The "Model Overview" screen opens see Section ["6.1 Model Overview"](#).



## 6.1 Model Overview

The "Model Overview" screen contains detailed model/version information on the chosen catalogue.

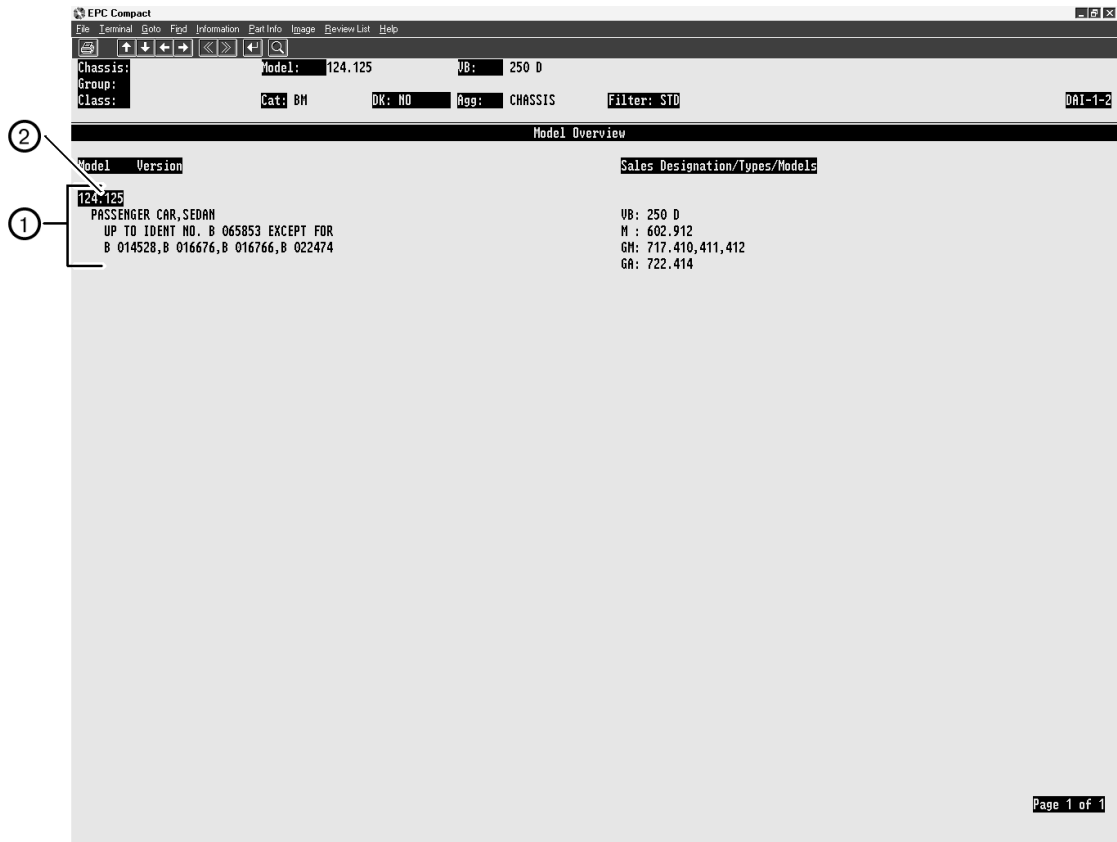

EPC4E074

- ① **Model/version information**      Contains detailed information on the selected model and the catalogue.
- ② **Sensitive field**              Confirms the model overview.
  - ⓘ Note the following:
    - You should check the data listed in the screen before confirming it.
    - You use the **Return** key to go back a screen.



- Select the sensitive field ②.
- ⇒ The "Group Index" appears.
  - 📖 see Section "[11 Standard Group Index](#)".



- Confirms.
- ⇒ The "Group Index" appears.
  - 📖 see Section "[11 Standard Group Index](#)".

## 7 Data Card

You can display the data card using the key combination **Ctrl** + **F6**.

You need the information from the data card to determine the correct part (e. g. checking footnotes, validity, SAs, code, ...)



The prerequisite is that you enter a complete vehicle ID number in the EPC initial screen and that the data card exists in the system.

**EPC Compact**

File Terminal Goto Fpd Information Part Info Image Review List Help

Chassis: WDB202080 1F 542375 Model: 202.080 1F 542375 JB: C 200

Group: Cat: B1+ DK: GR/SA Bgg: CHASSIS Filter: STD DAI-1-2

**Data Card Display Window**

Vehicle Data

Chassis No.:	WDB2020801F542375 0	Axles	Paint
Engine No.:	111945 10 005326	Front 1:	Code 1 189
Type:	C200T	Front 2:	Code 2
Order No.:	0 7 293 08560	Rear 1:	Code 3
Transmission:	717417 07 189617	Rear 2:	Code 4
Transfer Case:			Code 5
P.T.O.:			
Aufbau:			Interior 746

Cab: 00000 Locks

Heater: 0629102697 Door: #####

Lights: VALED Steering: #####

Odometer: Trans: #####

Platform: Fuel: #####

Trailer: Retarder: 6 970109

Rims: Service nr.:

Wiper: Winch:

Special Version Codes

212 240 331 412 515 551 570 580 584 593 645 657 673 682 807 873 875 959 988

Special Version Numbers

01 12412/48	03 12412/48	07 12412/48	09 12412/48	13 12412/48	15 12412/48	18 12412/48	20 12412/48	22 12412/48	26 14055/31
32 14120/24	32 14187/19	35 14120/24	35 14155/19	40 14072/63	41 14143/02	42 14005/05	42 14140/07	46 14034/29	46 14034/36
46 14120/24	52 14053/01	52 14053/02	52 14069/01	54 14006/04	54 14020/01	54 14097/05	67 57146/23	67 57148/04	68 57067/28
68 57187/14	68 57189/17	68 57230/07	68 57387/03	68 57424/02	68 57424/11	68 57659/06	69 57148/04	69 57184/09	69 57563/04
72 57062/06	72 57090/01	72 57090/02	72 57090/04	72 57146/23	72 57148/04	72 57242/08	73 57062/06	73 57090/01	73 57090/02
73 57090/04	73 57146/23	73 57148/04	74 57146/23	75 57148/04	75 57275/07	75 57275/10	75 57275/11	75 57275/14	78 57095/03
82 14097/05	82 57061/02	82 57062/06	82 57067/28	82 57090/01	82 57090/02	82 57090/04	82 57358/08	82 57358/25	82 57358/28
82 57358/42	82 57540/01	83 57093/01	83 57373/19	86 57093/01	88 57153/58	88 57275/07	88 57275/10	88 57275/11	88 57275/14
91 57063/01									

EPC4E075

### Data Card Display Window

Displays structured information on the data card.

The contents cannot be edited.

## 8 Information Page

The "Information Page" submenu displays the information used by the EPC for evaluating the validity data (e.g. model, serial number).

### The EPC evaluates:

- Inputs in the EPC initial screen,
- The data card (if available).

 The contents of the "Information Page" submenu **cannot** be edited.

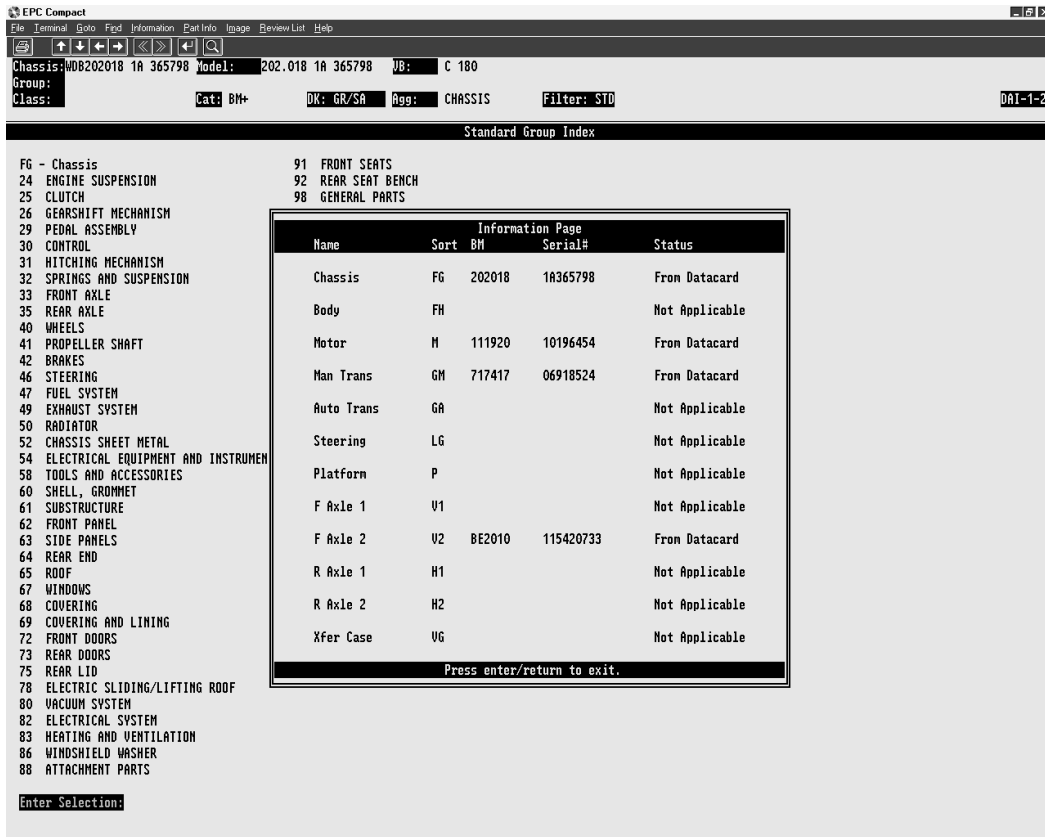

EPC4E076

<b>Name</b>	Contains the name (e.g. chassis) assigned to the model (BM).
<b>Sort</b>	Contains the abbreviation assigned to the name. Possible abbreviations: M Engine GM Manual Transmission GA Automatic Transmission P Platform FH Body LG Steering V1 Front Axle 1 V2 Front Axle 2 H1 Rear Axle 1 H2 Rear Axle 2 VG Transfer Case FG Chassis
<b>BM</b>	Contains the selected model (e.g. 202018).

<b>Serial#</b>	Contains the characters of the ID number which follow the model number (e.g. 1A365798).
<b>Status</b>	The following entries are possible:
<b>From Datacard</b>	The information is determined from the data card.
<b>Not Applicable</b>	The catalogue is not valid for the current selection.
<b>Not Loaded</b>	The appropriate catalogue was not yet determined.
<b>More than one</b>	There are several selection options for this type.

## 9 Finding SAs

You can call up the SA catalogue directly by entering the appropriate SA number in the "Find SA" submenu.



With a stored data card, you can display the SA fitted in a vehicle (with stroke) by calling up this data card (via "Information/Data Card" in the menu bar).

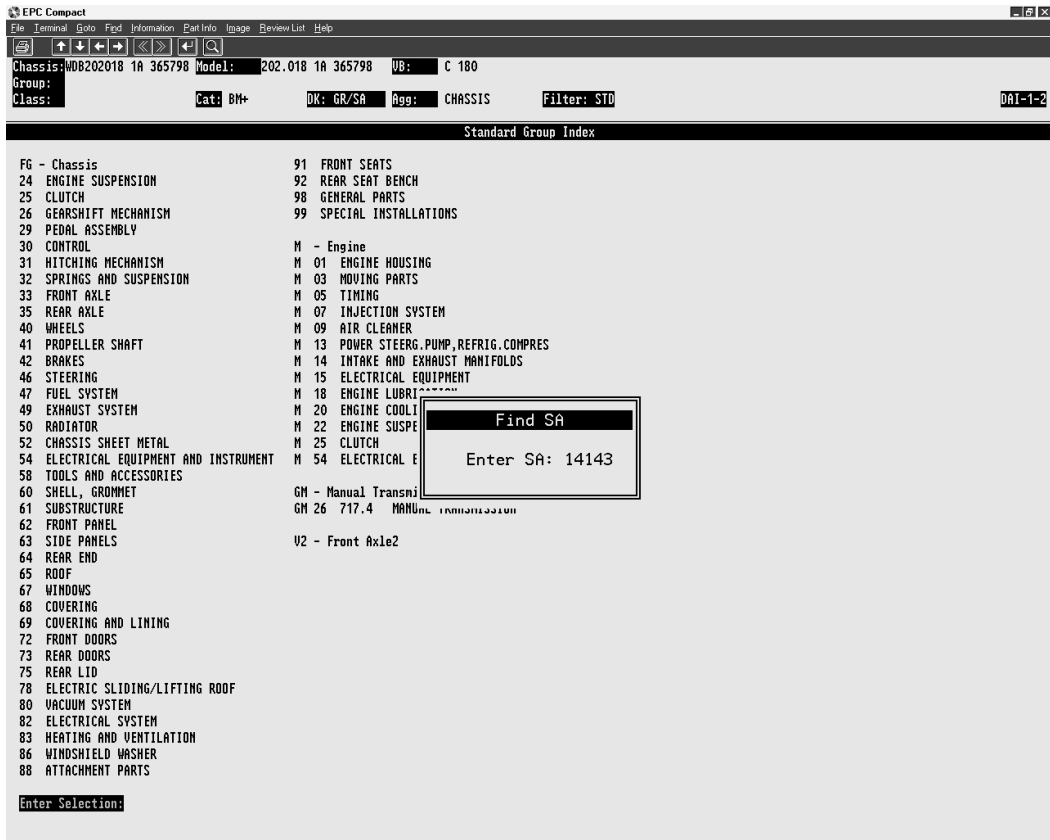

### Enter SA

For **entering** the complete SA number without the stroke number (e.g. 14143). You should confirm the entry with **Return**. The "SA Index" is then called up.

see Section "13 SA Index (Special Versions Index)".

see Section "14 SA Stroke Index".

## 10 Filter Menu

The "Filter Menu" displays the data filter settings, which can be modified, if necessary. Whether you are allowed to modify individual data filter settings or not depends on the system status.



The system activates or deactivates individual or all data filters, depending on the selection made to date.

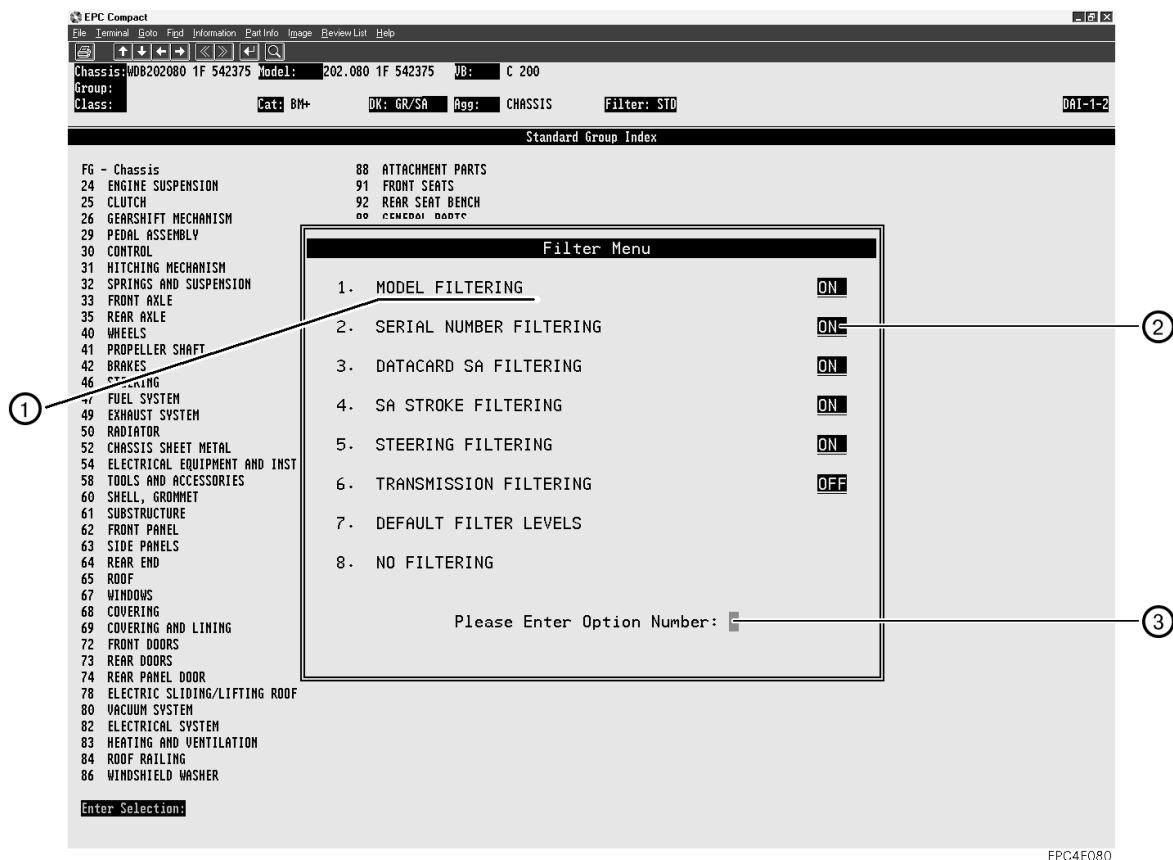

- ① **Action button** For activating (ON) or deactivating (OFF) the data filter concerned by clicking it with the left mouse button.
  - ① The action button functions as a toggle switch (ON or OFF).
- ② **ON / OFF** Status of the data filter.
- ③ **Please Enter Option Number** For activating (ON) or deactivating (OFF) the data filter in question by entering the item number of this data filter (e. g. "1" for MODEL FILTERING).
  - ① The input field functions as a toggle switch (ON or OFF).

### Filter

#### Explanation of the filter settings:

#### 1. MODEL FILTERING

Prerequisite: Model defined in the system.

**ON** Filters model-specific information when you are searching for parts.  
 ① The SA index only lists the SAs that are valid for the model in question.

**OFF** You can access **all** parts information within a catalogue. Parts information that is not valid for the selected model is also listed.

## 2. SERIAL NUMBER FILTERING

Prerequisite:

- Vehicle/aggregate ID number defined in the system.
- Chassis, engine, or body are selected as catalogues.

**ON** The parts information (including footnotes) is filtered using the serial number. Depending on the structure of the numeric code, the last 6 or 7 figures of the vehicle/aggregate ID number are evaluated.

**OFF** The serial number is not considered during the selection.

## 3. DATACARD SA FILTERING

Prerequisite:

- Vehicle/aggregate ID number defined in the system.
- Data card is stored.

**ON** SA information is filtered using the data card, taking the selected group into account. The codes of the data card are considered in the parts determination.

 With older models and aggregates, the code is not taken into account.

**OFF** Allows access to information on all SAs that can be fitted, taking the model and group into account.

The codes of the data card are no longer taken into account.

**"DATACARD SA FILTERING" should be deactivated in the following cases:**

- When determining parts for “retrofitting”.
- If there are inconsistencies between the data card and the parts documentation.

## 4. SA STROKE FILTERING

Prerequisite:

- Vehicle/aggregate ID number defined in the system
- Data card stored
- “DATACARD SA FILTERING” activated.

**ON** SA stroke information is filtered using the data card, taking the selected group into account.

**OFF** Enables access to information on all SAs that can be fitted, taking the selected type, group, and SA into account.

**The "DATACARD SA STROKE FILTER" should be deactivated in the following cases:**

- When determining parts for “retrofitting”.
- If there are inconsistencies between the data card and the parts documentation.

## 5. STEERING FILTERING

Prerequisite: vehicle/aggregate ID number defined in the system.

**ON** The parts information is filtered using the steering assembly (LS or RS) and the group. The information on the steering assembly is contained in the vehicle/aggregate ID number.

**OFF** You can access information on both types of steering assembly (LS and RS).

- 6. TRANSMISSION FILTERING** Prerequisite: Vehicle/aggregate ID number defined in the system.
- ON** The parts information is filtered using the transmission type (GA or GM) and the group. The information on the transmission type is contained in the data card or aggregate ID number.  
 Only active for passenger cars.
- OFF** You can access information on all transmission types, taking the selected model into account.
- 7. DEFAULT FILTER LEVELS** If the filter settings defaulted by the system have been changed, you can reset the filter settings to the system defaults using "DEFAULT FILTER LEVELS".
- 8. NO FILTERING** All data filters are deactivated ("OFF").

## 11 Standard Group Index

The standard group index selection list displays the group names concerned together with their group number, taking the model into account. By **choosing** a group, you can restrict the parts information displayed, to the sub-group or SA.

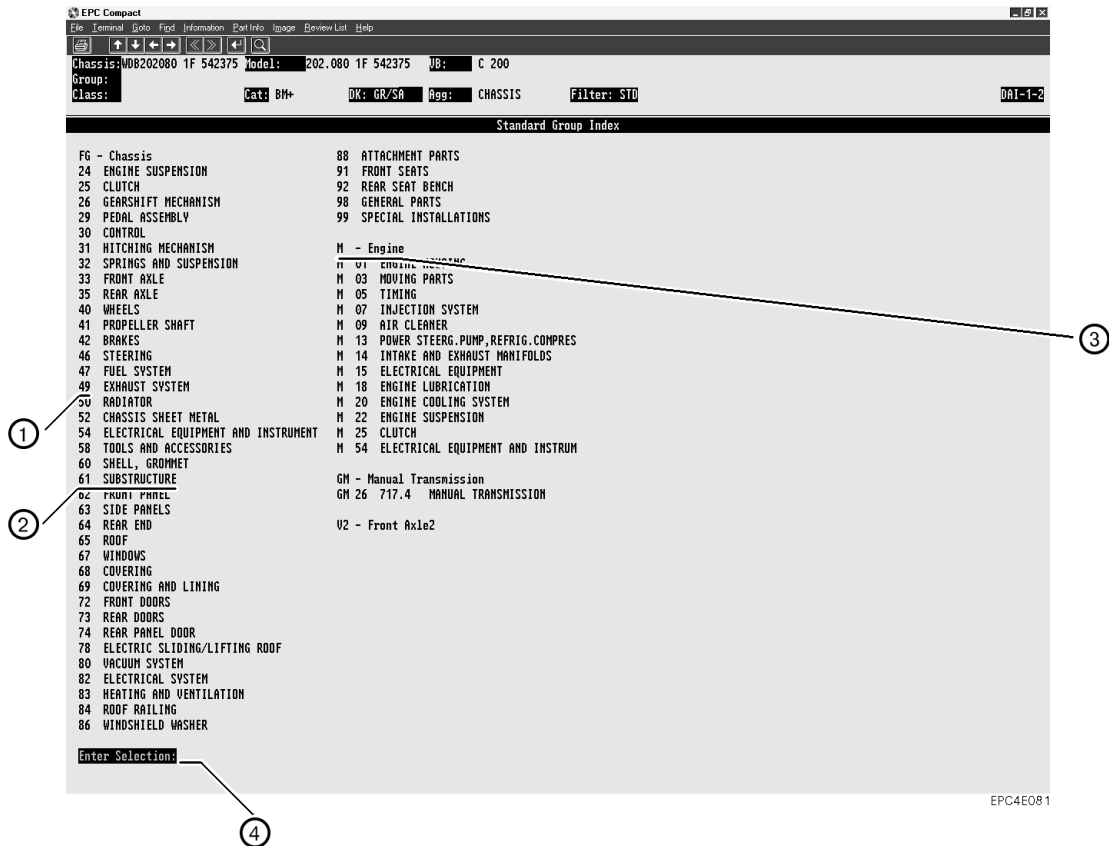

- ① **Group no.** The group number assigned to the group name (e.g. 49).
- ② **List entry** **For selecting** the desired group entry (e. g. 61 substructure).  
 Only individual selections possible.
- ③ **Catalogue** For calling up the desired catalogue.  
 You can see the selected catalogue under Agg in the information area.
- ④ **Enter Selection** For entering  
 – the appropriate group no. (e. g. 49).  
 – the catalogue abbreviation (e. g. FG for chassis, M for engine, ...).  
 You should confirm the entry with .

## 12 Aggregate Index

If the EPC cannot determine which aggregate is valid for the selection you have made, the available 6-character aggregate models are listed in the "AGGREGATE INDEX". You can choose the desired aggregate by **selecting** it.



If you press the **Return** key, you return to the previous screen.

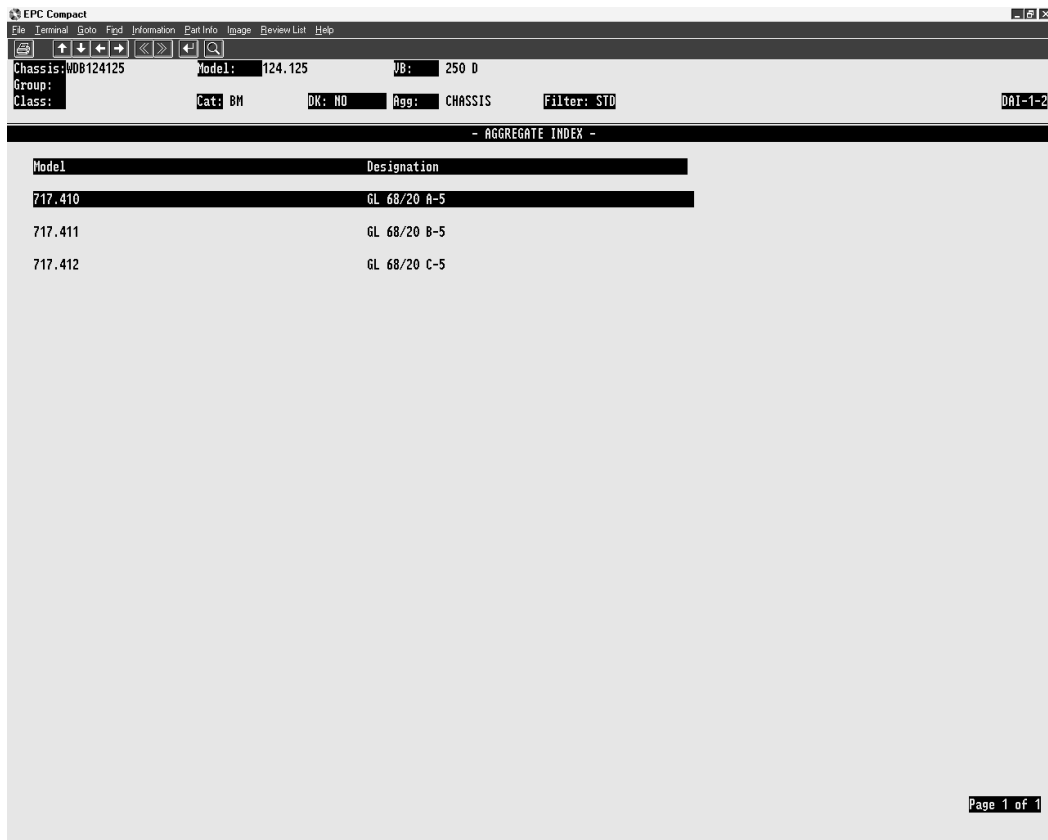

EPC4E092

### List entry

For selecting the desired aggregate.

- You should note the following:
  - Only individual selections are possible.
  - If you press the **Return** key, you return to the previous screen.



### Choosing a list entry

- Select the desired list entry.
- ⇒ The aggregate is selected.
- Position the selection bar on the desired list entry.
- Confirm.
- ⇒ The aggregate is selected.



### 13 SA Index (Special Versions Index)

The SA index lists the special versions that can be fitted for the selected group.

There are various possibilities:

- If a **data card** is stored and "DATACARD SA FILTERING" is active, the SA index only lists the SAs that are actually fitted in the model.
- If a **data card** is stored **without SA entries** and "DATACARD SA FILTERING" is active, you go directly to the group index (in the standard parts catalogue).  see Section "[11 Standard Group Index](#)".
- If a **data card of an older model (only with CODE entries)** is stored and "DATACARD SA FILTERING" is active, the SA index lists all the SAs that can be derived from the CODE entries and which are valid for this model.
- If "DATACARD SA FILTERING" is deactivated or **no data card** is stored, all the SAs that are valid for this catalogue are listed.



In the cars class, SA parts may also be contained in the standard parts catalogue.

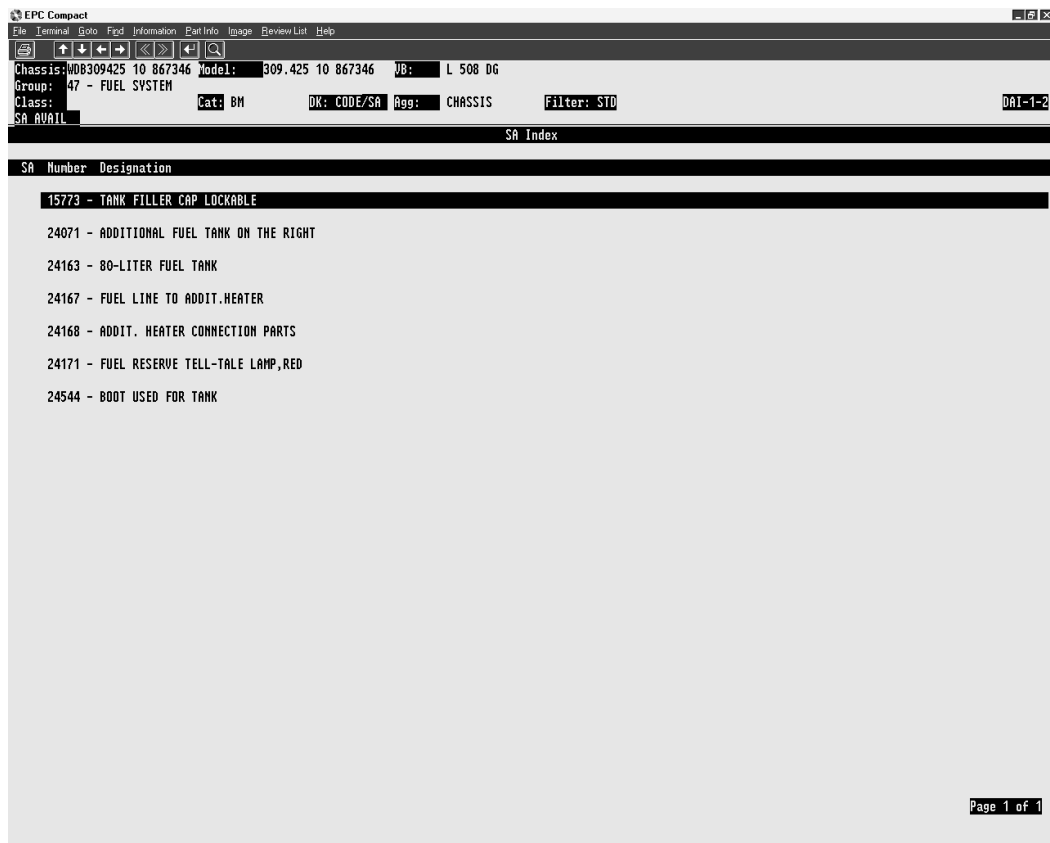

The corresponding SA parts are listed in the illustrated page, possibly together with the serial parts.



EPC4E083

#### List entry

For selecting the desired special version (SA).

- If the list entry contains the remark "**See Standard Microfiche**," the parts are contained in the standard parts catalogue. In this case, you can go directly to the standard parts catalogue using the following functions:
  - Menu bar "Goto/BM/SA F8"
  - With 
  - With the right mouse button
- If the SA is **valid** for the selected model, you select the SA and go to the "SA Stroke Index".  see Section "[14 SA Stroke Index](#)".
- If the SA is **not valid** for the selected model, a pop-up menu appears with the message "Special Version does not apply to this vehicle". Confirm the pop-up menu with "OK".

## 14 SA Stroke Index

The SA Stroke Index lists the variants of the special version that can be fitted for the chosen special version (SA).

There are various possibilities here:

- If a **data card** is stored and the "DATACARD SA FILTERING" and "SA STROKE FILTERING" filters are active, the "SA Stroke Index" only lists the strokes that are actually fitted in the model.
- If a **data card of an older model (only with CODE entries)** is stored and "DATACARD SA FILTERING" is active, the "SA Stroke Index" lists all the strokes that can be derived from the CODE entries and which are **valid** for this model.
- If **no data card** is stored or "DATACARD SA FILTERING" and "SA STROKE FILTERING" are deactivated, the index lists all the strokes that **can be fitted** for the model.



In the cars class, SA parts may also be contained in the standard parts catalog. The corresponding SA parts are listed in the illustrated page, possibly together with the serial numbers.

The screenshot shows the EPC Compact software interface. At the top, there is a menu bar with options: File, Terminal, Goto, Find, Information, Part Info, Image, Review List, Help. Below the menu bar, there is a status bar displaying vehicle information: Chassis: WDB309425 10 867346, Model: 309.425 10 867346, VB: L 508 DG, Group: 47 - FUEL SYSTEM, SA: 15773, TANK FILLER CAP LOCKABLE, Class: SA, Cat: SA, DK: CODE/SA, Agg: CHASSIS, Filter: STD, and DAI-1-2. The main display area is titled "SA Stroke Index" and shows a table with the following columns: Stroke, Remarks, Type Models, and Ftn. The table contains the following entries:

Stroke	Remarks	Type Models	Ftn.
15773		TANK FILLER CAP LOCKABLE	
13		309 002/020 - 029/080 - 089/091/102/120 - 129/180 - 189/191/380 - 389/391/402/404 424 - 427/429	
		310 302/304/324 - 327/329/386/389/402/404/424 - 427	
		313 382/386/389/402/404/424/427/429	

Below the table, there is a section for "For use with" showing SA 24071 and SA 24169. The bottom right corner of the screenshot shows "Page 1 of 1" and "EPC4E084".

- ① **SA info** Contains the chosen SAs with SA number and SA name.
- ② **List entry** For **selecting** the desired SA stroke.
- If the list entry contains the remark "See standard microfilm," the parts are contained in the standard parts catalogue. In this case, you can go directly to the standard parts catalogue using the following function:
    - Menu bar "Goto/BM/SA F8"
    - With
    - With the right mouse button
- ③ **Ftn.** Indicates whether footnotes are available for a particular list entry. see Section "17.3 Footnotes".

## 15 Standard Sub-Group Index

The selection list of the standard sub-group index lists the appropriate sub-group names with sub-group numbers, taking the model and the selected group into account.



If only one sub-group is assigned to the selected group, the "Standard Sub-Group Index" is not displayed and the illustrated page is called up straight away.

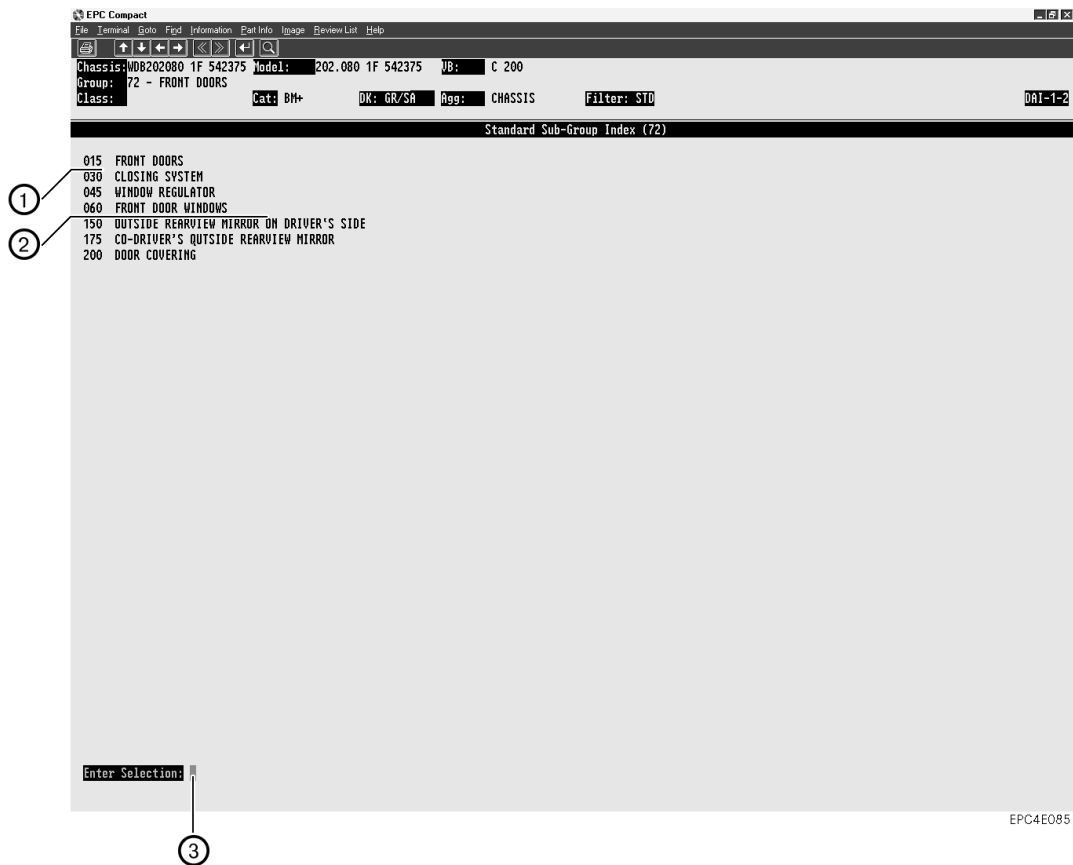

- ① **Sub-group no.** The sub-group number (e. g. 015) assigned to the sub-group name.
- ② **List entry** For **selecting** the appropriate list entry (e. g. 015 front doors).  
 ⓘ The list entry may contain information on where the part was fitted (e. g. front/back, ...).
- ③ **Enter selection** For **entering** the appropriate sub-group number (e.g. 015). You should confirm the entry with Return.

## 16 Illustrated Page

The "illustrated page" screen contains a graphical representation of the parts that are assigned to the selected group/sub-group or SA.

You can call up the desired parts in the "illustrated page" screen by:

- Selecting the screen item number (sensitive field).
- Entering the screen number(s) in the "Enter Callout" input field (separated by blanks).

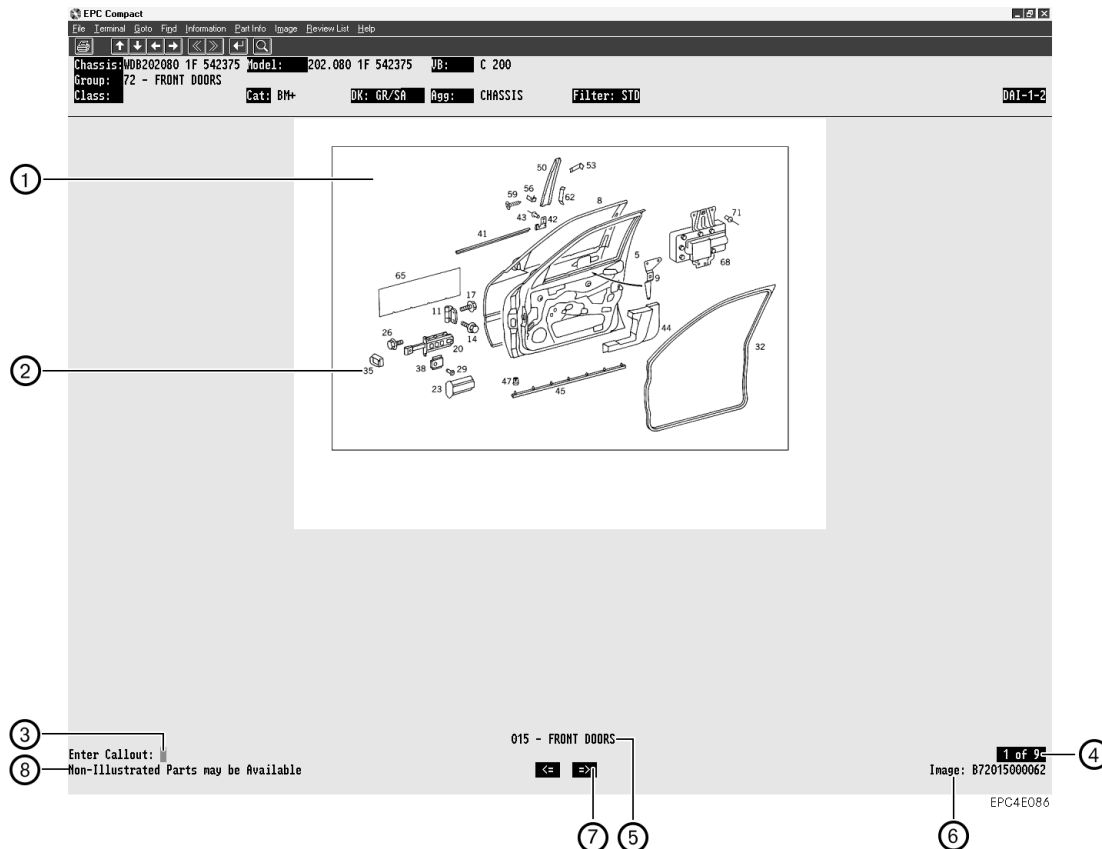

- ① – A group/sub-group or SA can consist of one or more illustrated pages.
- An illustrated page may contain several variants and models.
- SA parts can also be represented in an illustrated page of the standard parts catalogue.



- ① **Illustrated page**

The illustrated page contains a graphical representation of the parts with screen item numbers.

If the cursor is positioned on the illustrated page, you can zoom in (magnifying glass) by pressing the **right** mouse button and keeping it depressed.

  - ① In addition to the parts illustration, further symbols are used in the illustrated page.
    - Repair kits are identified with the icon .
    - Seal ring kits are identified with the icon .
- ② **Screen item number**

For choosing the desired part with the mouse. The screen item number is sensitive. The selected screen item number is entered in the "Enter Callout" input field.

  - ① You can call up a maximum of 24 screen item numbers.

If you want to choose more than 24 screen item numbers, select "Part Info/All records F6" in the menu bar. All screen item numbers are displayed in the parts list.

 see Section "16.3 All records - F6".

- ③ **Enter Callout:** For entering the screen item number.  
Note:
- You can enter a maximum of 24 screen item numbers.
    - ① If you want to choose more than 24 screen item numbers, select "Part Info/All records F6" in the menu bar. All screen item numbers are displayed in the parts list.
  - If you enter the number with the keyboard, you must insert a blank after every screen item number.
  - Invalid screen item numbers are not accepted.
  - Screen item numbers that are selected twice are only accepted once.
- ④ **Information field** Displays the number of the current illustrated page and the total number of illustrated pages that can be selected.
- ⑤ **Sub-group information** Indicates the sub-group to which the displayed illustrated page is assigned.  
① This information field is only visible for illustrated pages in standard parts catalogues.
- ⑥ **Image** Displays the name of the image currently displayed, in the form of a number.
- ⑦ **Arrows** Scroll between the illustrated pages of the design group, by selecting them with the left mouse button.
- ⑧ **Non-illustrated Parts may be Available** In exceptional circumstances, screen item numbers that are not illustrated can be assigned to the illustrated page.  
These parts are copied to the parts information
- by selecting "Part Info/All records F6" in the menu bar or
  - by choosing a screen item number to which the non-illustrated part is linked.
- 📖 see Section "[17 Parts Information/SA Parts Information](#)".  
📖 see Section "[16.3 All records - F6](#)".

#### Scrolling in illustrated pages

- ① When you scroll between illustrated pages, the screen item numbers that have already been entered are deleted from the input field.



- Select the left or right arrow icon.
- ⇒ Scrolls one page forwards or backwards.



- ⇒ Scrolls one illustrated page forwards.



- ⇒ Scrolls one illustrated page backwards.

#### Zoom function (magnifying glass)



- Select the screen with the **right** mouse button and keep the mouse button depressed.
- ⇒ The zoom function is active in the area of the pointer.



- ① You can set the size of the zoom window to three different sizes in the "DBCP Configuration" screen. This can be called up via "Goto/Application Index" in the menu bar.

📖 see Section "[23 DBCP Configuration](#)".

#### Enlarging an illustrated page

📖 see Section "[16.1 Enlarging Illustrated Pages](#)".

### Printing illustrated pages

- i Only enlarged illustrated pages can be printed out.
  -  see Section "16.1 Enlarging Illustrated Pages".
  -  see Section "21 Printing".

### Calling up the "Parts Information" screen

- i The cursor must **not** be positioned on the illustrated page and at least one screen item number must be entered under "Enter Callout" .







- Click **right** mouse button  
or
- Select "Part Info/All records F6" in the menu bar  
or
- Choose "Help/Fkey/All records F6" in menu bar.
- ⇒ The "Parts Information" screen is displayed.  see Section "17 Parts Information/SA Parts Information".



- ⇒ The "Parts Information" screen is displayed.  see Section "17 Parts Information/SA Parts Information".

### Additional Information

- i
  - A part can be present on several illustrated pages within a catalogue.
  - If the part you are looking for is not on the illustrated page currently displayed, you must continue the search in other illustrated pages.
  - If you cannot see the installation location from the illustration (e.g. front/back), you should use the subgroup index to access the illustrated page for further information.
  - The only parts copied to the "Parts Information" are parts with screen item numbers in the "Enter Callout" input field. When you scroll between illustrated pages, the screen item numbers that have already been entered are deleted from the input field.
  - If the message **"THIS ILLUSTRATION IS NOT AVAILABLE AT THIS TIME"** appears, select "Part Info/All records F6" in the menu bar.
    -  see Section "16.2 This Illustration is not Available at this Time".
    -  see Section "16.3 All records - F6".
  - To choose and copy all items (incl. non-illustrated parts) to the parts information, select "Part Info/All records F6" in the menu bar. The parts information is called up automatically.
    -  see Section "16.3 All records - F6".
  - If a blank illustrated page is displayed, select "Part Info/All records F6" in the menu bar.
    -  see Section "16.3 All records - F6".

### 16.1 Enlarging Illustrated Pages

To help you identify the individual parts more easily, you can enlarge the current illustrated page by choosing "Image/Zoom" in the menu bar.



- You can also select screen item numbers in the enlarged illustrated page.
- The "Image/Zoom" function in the menu bar functions as a toggle switch (switches between enlarged and normal view).

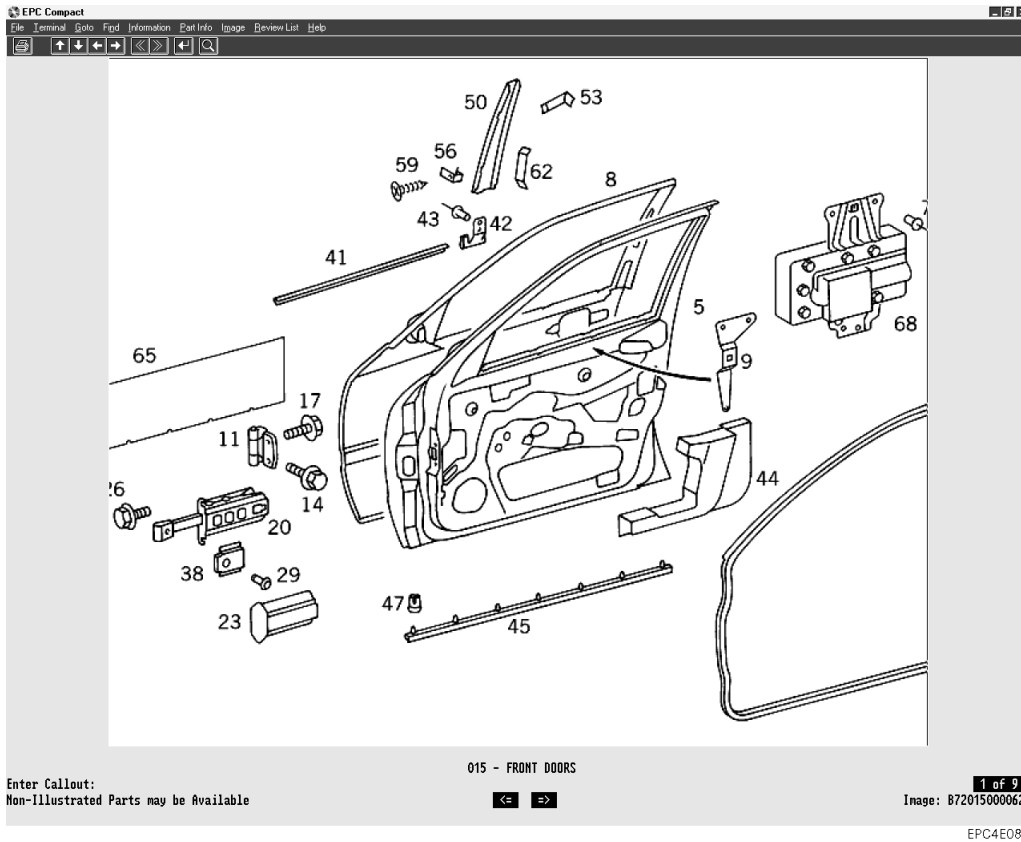

**Illustrated page** Section of an enlarged illustrated page.

#### Enlarge illustrated page



- Choose "Image/Zoom" in the menu bar.
- ⇒ The selected illustrated page is enlarged.

#### Moving a section of the enlarged illustrated page

- Choose the area you want to move by clicking the right mouse button and keeping it depressed (pan function).
  - The length of the line you draw determines the direction and the extent to which the section is moved.



- ⇒ Moves the section up or down.
- ⇒ Moves the section to the right or to the left.

### Printing illustrated pages



- Choose the magnifying glass icon (zoom function) in the toolbar.
- Choose "File/Print" in the menu bar or
- Click the button with the printer icon in the toolbar.



⇒ A hardcopy is created. see Section "21 Printing".

## 16.2 This Illustration is not Available at this Time

This screen is displayed if the part you are looking for is not shown on the SA illustrated page but on the illustrated page of the standard parts catalogue. In this case, choose "Part Info/All records F6" in the menu bar.

see Section "16.3 All records - F6".

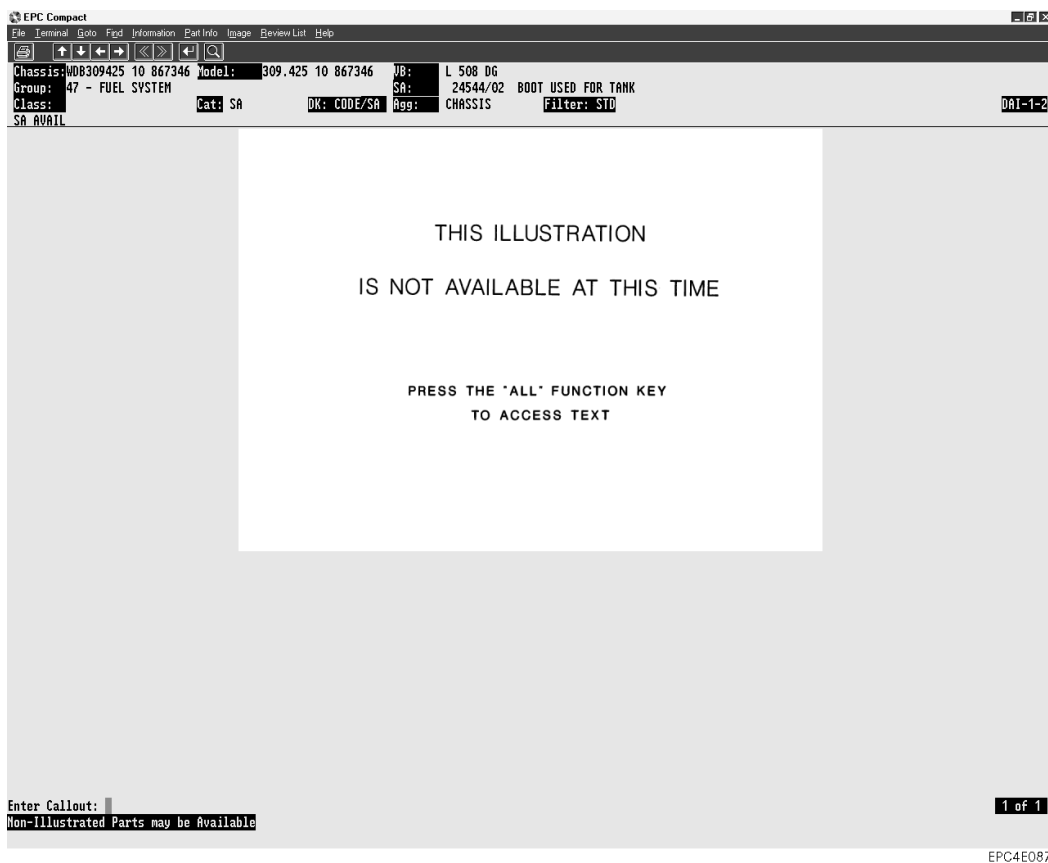

- Select "Part Info/All records F6" in the menu bar.
- ⇒ The "Parts Information" screen is displayed.
- or
- ⇒ The message **"Non-Illustrated Parts may be Available"** is displayed in the EPC message line. This refers to SA parts that are illustrated in the standard parts catalogue. You can go to the standard parts catalogue by choosing "Goto/BM/SA F8" in the menu bar.

### 16.3 All records - F6

You can only call up the function "All records F6" from the illustrated page.

**You need the function "All records F6":**

- To choose and copy all items (incl. non-illustrated parts) to the parts information.
- You can choose a maximum of 24 screen item numbers by selecting them in the illustrated page. If you want to choose more than 24 screen item numbers, call up the "All records F6" function via Part Info in the menu bar. All screen item numbers are displayed in the parts information.
- If the part you are looking for is not directly found in the illustrated page.
  - ❗ The screen item number in the parts information corresponds to the screen item number in the illustrated page.

**Result of All records F6:**

⇒ The "Parts Information" is displayed.

or

⇒ The message "**Non-Illustrated Parts may be Available**" appears in the EPC message line.

This refers to SA parts which are illustrated in the standard parts catalogue. You can go to the standard parts catalogue via the Menu bar "Goto/BM/SA F8".

## 17 Parts Information/SA Parts Information

The "Parts Information" screen

- lists the parts/part sets selected in the "illustrated page".
- allows you to identify the parts/part sets that will be copied to the "SELECTED PARTS LIST" with a star (\*).
- allows you to add a supplementary code (ES1-/ES2-CODE) to a part number.  
 see Section "19.2 ES Code Input (only possible in the parts information)".

### 17.1 Parts Information for Standard Illustrated Pages





Before a part is copied to the selected parts list using the  key or by selecting it, you should note the following:

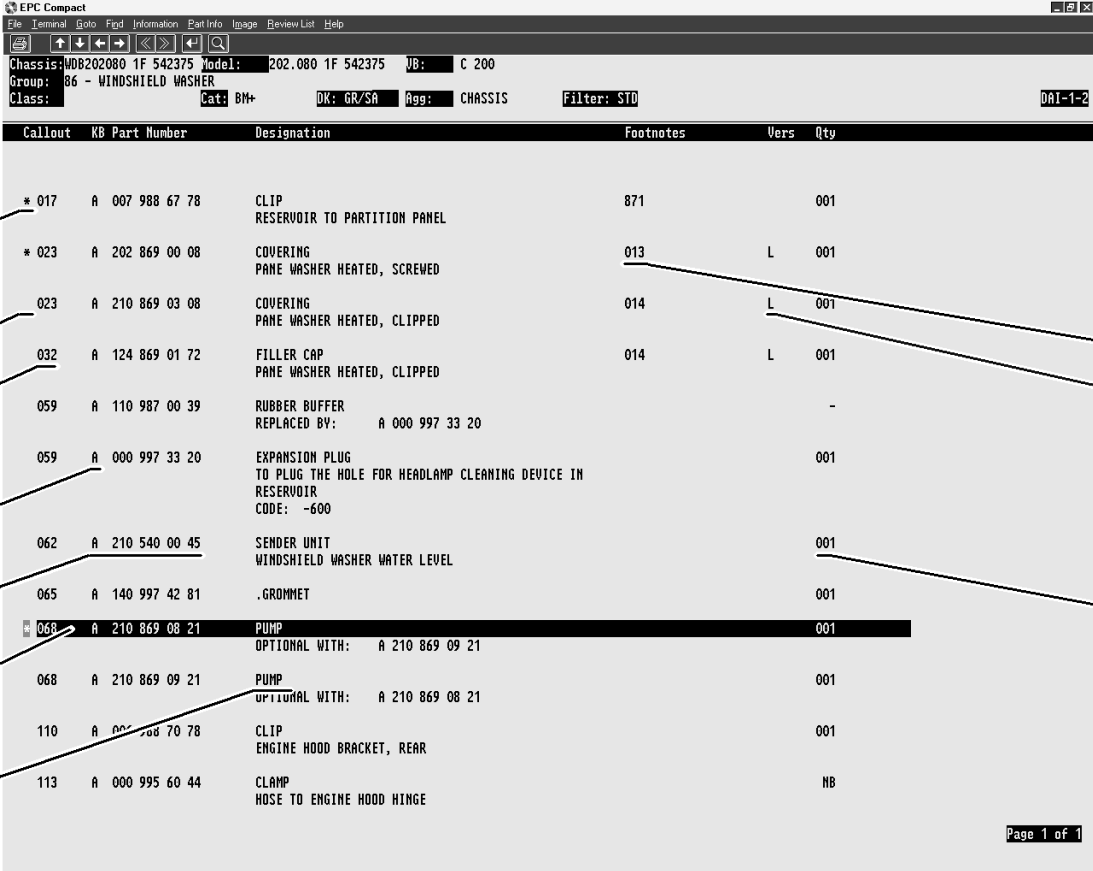







- Footnotes **must** be evaluated,
- You should take note of remarks such as "REPLACED BY" or "OPTIONAL WITH,"
- When choosing parts, you should take note of information, such as the installation location, repair kit, CODE, strokes, for example.



Callout	KB	Part Number	Designation	Footnotes	Vers	Qty
* 017	A	007 988 67 78	CLIP RESERVOIR TO PARTITION PANEL	871		001
* 023	A	202 869 00 08	COVERING PANE WASHER HEATED, SCREWED	013	L	001
023	A	210 869 03 08	COVERING PANE WASHER HEATED, CLIPPED	014	L	001
032	A	124 869 01 72	FILLER CAP PANE WASHER HEATED, CLIPPED	014	L	001
059	A	110 987 00 39	RUBBER BUFFER REPLACED BY: A 000 997 33 20			-
059	A	000 997 33 20	EXPANSION PLUG TO PLUG THE HOLE FOR HEADLAMP CLEANING DEVICE IN RESERVOIR CODE: -600			001
062	A	210 540 00 45	SENDER UNIT WINDSHIELD WASHER WATER LEVEL			001
065	A	140 997 42 81	.GRONMET			001
* 068	A	210 869 08 21	PUMP OPTIONAL WITH: A 210 869 09 21			001
068	A	210 869 09 21	PUMP OPTIONAL WITH: A 210 869 08 21			001
110	A	000 988 70 78	CLIP ENGINE HOOD BRACKET, REAR			001
113	A	000 995 60 44	CLAMP HOSE TO ENGINE HOOD HINGE			HB

EPC4E089

- ① **List entry** For selecting the appropriate part.
- ② **Star** All parts which are given a star \* are copied to the selected parts list.  
 see Section "18 Selected Parts List".
- You can set the star using  or by selecting it.
  - You can remove the star using  or by selecting it.

- ③ **Input field** You can enter the following characters in the input field:
- X** If the information "REPLACED BY" is displayed in the "Designation" column, **only** the replacement parts are copied to the "SELECTED PARTS LIST" when you enter "X". The "replaced" parts are **not** copied.  
 see Section "18 Selected Parts List".
- W** If the information "OPTIONAL WITH" is displayed in the "Designation" column, all "optional parts" are copied to the "SELECTED PARTS LIST" when you enter "W".  
 see Section "18 Selected Parts List".
-  You **must** confirm the entries and then transfer them to the "SELECTED PARTS LIST" with .
- ④ **Callout** Contains the screen item number chosen from the illustrated page.  
 If a list entry in this column does not have a screen item number listed with it, this entry refers to a part that was not displayed in the illustrated page.
- ⑤ **KB** Code letter for the part number.  
 The following codes (KB) are possible at present:
- |            |                         |
|------------|-------------------------|
| <b>A</b>   | Design part number (MB) |
| <b>N</b>   | Standard part number    |
| <b>W</b>   | Tool part number        |
| <b>B6</b>  | Accessories part number |
| <b>HWA</b> | AMG part number         |
| <b>Q</b>   | Supplier number         |
- ⑥ **Part Number** Part number of the selected part.
- ⑦ **Designation** Contains the designation of the selected part, possibly with additional information.  
 Example:
- REPLACED BY** The part number has been replaced.  
 If an item marked as "REPLACED BY" has footnotes, the footnotes **must** be evaluated as they may contain the remark "First exhaust stock of old parts".
- OPTIONAL WITH** You have the option of fitting another part.
- — Part designations that are indented with bullets are subordinate parts, in other words they are components of the part/part set that is displayed directly above this entry, with fewer bullets or no bullets at all.
  - The parts can also be ordered individually.
- Code** You should consider the code specifications.  
 Example
- |              |                                     |
|--------------|-------------------------------------|
| Code: 600    | = <b>with</b> code 600              |
| Code: -600   | = <b>except for</b> code 600        |
| Code 580/581 | = Code 580 <b>or</b> 581            |
| Code 316+815 | = Code 316 <b>and</b> with Code 815 |
-  When choosing parts, you should note the additional information on the installation location, repair kit, strokes, for example.
- ⑧ **Footnotes** If additional information is available in the form of footnotes, corresponding footnote numbers are displayed.  see Section "17.3 Footnotes".  
 You can call up footnotes via Menu bar "Part Info/Footnote".  
 Footnotes must always be evaluated.

⑨ **Vers**

Contains version codes.  
Example:

<b>L</b>	Left-hand Steering
<b>R</b>	Right-hand Steering
<b>A</b>	Automatic Transmission
<b>M</b>	Mechanical Transmission

① The version codes can also be combined (e. g. LA=Left-hand steering, automatic transmission).

⑩ **Qty**

Contains the required quantity of the part.  
The following entries are also possible:

<b>NB</b>	As required.
-	Part has been replaced by another part.
?	Part without quantity. The quantity must be specified accordingly.

① The quantity of parts can be changed in the "SELECTED PARTS LIST" using the "Add" function.  see Section "[19 Add](#)".



If a list entry that has already been entered in the "SELECTED PARTS LIST" is selected again to be copied to the "SELECTED PARTS LIST", the "Duplicate Part" submenu is opened.

 see Section "[17.4 Duplicate Part](#)".

#### Transferring parts to the "SELECTED PARTS LIST"



- Select the desired list entry.
- ⇒ A star "\*" appears in front of the selected list entry in the input field and the part is transferred to the "SELECTED PARTS LIST".



- ⇒ A star "\*" appears in front of the selected list entry in the input field and the part is transferred to the "SELECTED PARTS LIST".

#### Deleting parts transferred to the "SELECTED PARTS LIST"



- ⇒ The star in front of the selected list entry in the "input field" is deleted and the part is removed from the "SELECTED PARTS LIST" when you update the list.  
 see Section "[18.1.8 List Update](#)".

#### Calling up a specific page



- ⇒ Opens the "Goto page" submenu in a multi-page part index. You can use this to enter a page number and go directly to a specific page.

## 17.2 Parts Information for SA Illustrated Pages

In the "SA Parts Information" screen, a distinction is made between:

- Parts that are required for the SA,
- Parts that are no longer required when the SA is fitted.

Callout	KB + Part Number	KB - Part Number	Designation	Footnotes	Vers	Qty
001	A 000 471 18 30	A 100 470 01 05	FILLER CAP REPLACED BY: A 000 471 71 30			-
001	A 000 471 71 30	A 100 470 01 05	FILLER CAP WITH 2 KEYS		407	002
004	A 000 471 11 80		.GASKET REPLACED BY: A 000 471 10 80			-
004	A 000 471 10 80		.GASKET		002	002
----	A 000 760 06 06		KEY		407 001	002
----	A 601 471 00 93		KEY BLANK		002	002

EPC4E090

- ① **+ Part number**                      Contains the parts that are required for fitting the SA.
- ② **- Part number**                        Contains the parts that you may have to remove when fitting the SA.

**i** The remaining elements in the "SA Parts Information" screen correspond to the elements in the "Parts Information" screen for standard illustrated pages. see Section ["17.1 Parts Information for Standard Illustrated Pages"](#)

## 17.3 Footnotes

Footnotes refer to further important information that has to be considered when selecting parts. The "Footnotes" submenu is opened when you select a list entry with footnotes in the parts information or in the SA stroke index via the menu bar "Part Info/Footnotes".

- i** If only one screen item number has been selected in the "illustrated page" screen, the "footnotes" submenu is opened automatically when you open the parts information, provided that footnotes have been assigned to this screen item number.

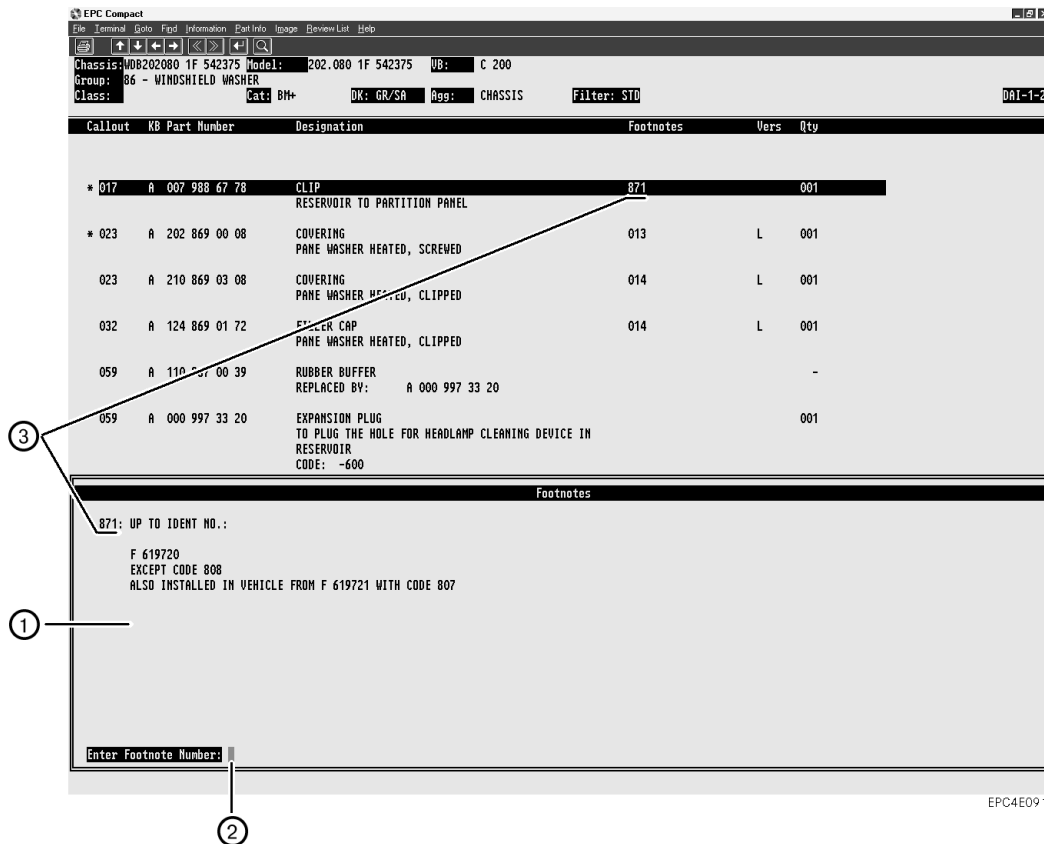

- 1 Footnotes window** Displays the footnotes information.
- i** If you start the system by entering the vehicle ID number with a stored data card, the paint CODE (CODE 1-5) and special version CODE are also displayed in the footnotes window.
- 2 Enter Footnote Number** For entering a complete footnote number (e. g. 014) from the parts information. The associated footnote text is displayed after you press Return.
- 3 Footnote number** Footnote number which is assigned to the following text.



- Select "Part Info/Footnotes" in the menu bar
- ⇒ The "Footnotes" submenu is opened or closed.

## 17.4 Duplicate Part

If a part number is already contained in the selected parts list and you select it **again** in the parts information with , the "Duplicate Part" pop-up menu is displayed.

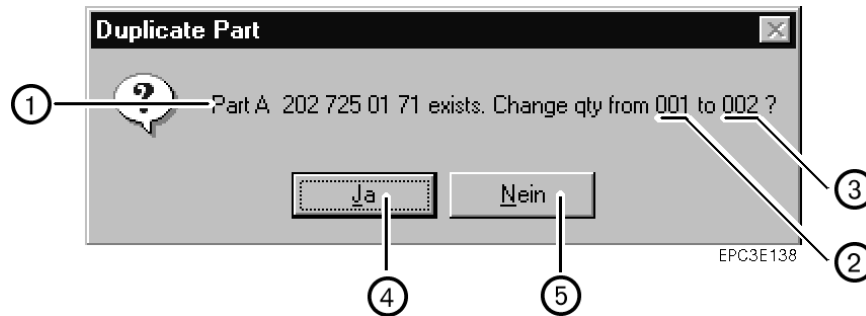

- ① **Part number** Part number to which this message applies.
- ② **Quantity present** Displays the quantity of the specified part number already entered in the "SELECTED PARTS LIST".
- ③ **New quantity** Displays the new quantity of the specified part number in the "SELECTED PARTS LIST" which applies after the part number has been changed.
- ④ **Yes** Confirms that the quantity of the part number specified is to be changed in the "SELECTED PARTS LIST".  see Section "[18 Selected Parts List](#)".
- ⑤ **No** Closes the "Duplicate Part" pop-up menu and cancels the "Add Part Number" procedure. The quantity of the selected part is not changed in the Selected Parts List.

## 18 Selected Parts List

The "SELECTED PARTS LIST" screen lists the parts/part sets you have selected in the parts information.







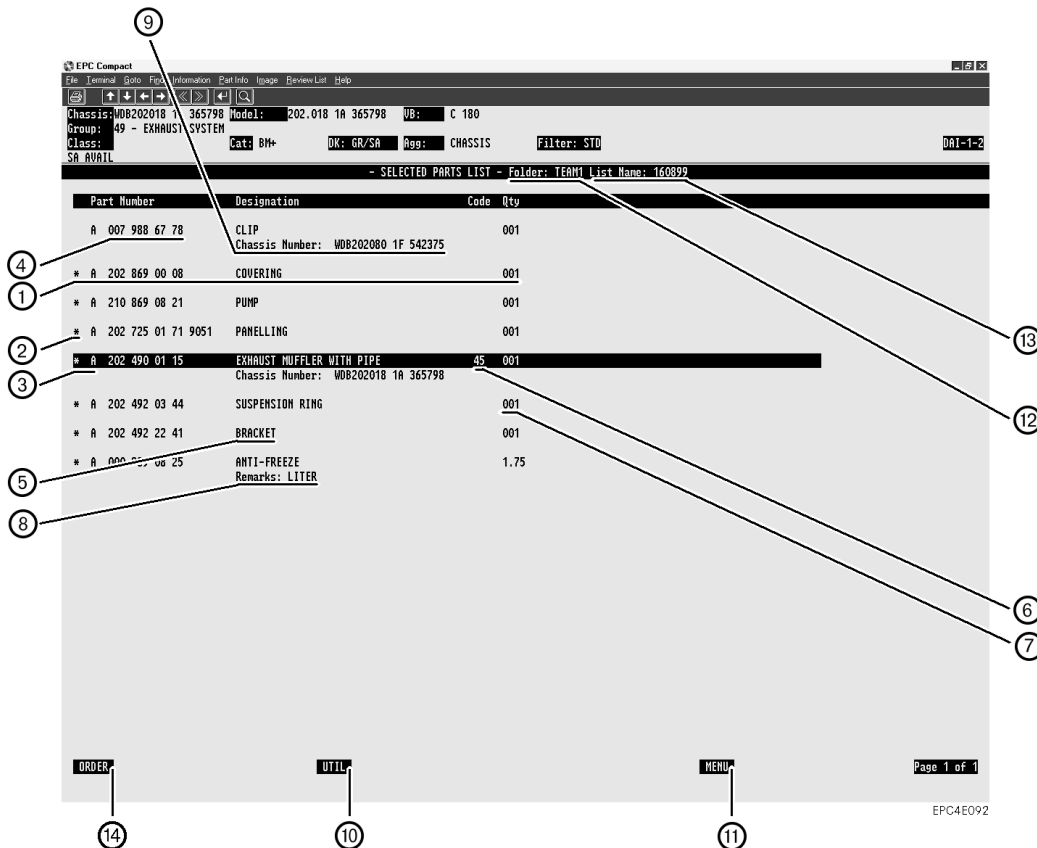





The selected parts list can be

- printed,
- stored as a file in a directory,
- printed or stored as a parts order.

 You can call up the "SELECTED PARTS LIST" by choosing "Review List/View list" in the menu bar.



- ① **List entry** For selecting the desired part.
- ② **Star** You can use the star "\*" to control whether a list entry remains or is deleted from the selected parts list after the list is updated.  
 see Section "18.1.8 List Update".
- ③ **KB** Code letter of the part number.  
The following code letters (KB) are available at present:
- |            |                         |
|------------|-------------------------|
| <b>A</b>   | Design part number (MB) |
| <b>N</b>   | Standard part number    |
| <b>W</b>   | Tool part number        |
| <b>B6</b>  | Accessories part number |
| <b>HWA</b> | AMG part number         |
| <b>Q</b>   | Supplier number         |
- ④ **Part number** Part number of the selected part.
- ⑤ **Designation** Contains the designation of the selected part.

- ⑥ **Code** Contains the specified code of the selected part.  
 see Section "18.1.4 Change Code".
- ⑦ **Qty** Contains the quantity of the part. The quantity can be changed as required via the "Menu ⑪ / Change Quantity" submenu.  see Section "18.1.3 Change Quantity".
- ⑧ **Remarks** Contains a remark made by the user on the selected part.  
 see Section "18.1.6 Change Remarks".
- ⑨ **Veh. Ident. No.** Displays the vehicle ID number entered in the EPC initial screen before the part was selected. If further parts have been transferred to the Selected Parts List after this part, these listed parts also belong to the displayed vehicle ID number.  
If you access the EPC using a different vehicle ID number and without deleting the Selected Parts List beforehand, the new vehicle ID number is listed for the first new part transferred to the list. All parts that are listed after this then belong to this new vehicle ID number.
- ⑩ **UTIL** Opens the "LIST UTILITIES" submenu for administrating the selected parts lists (e.g. storing, copying, deleting).  see Section "18.2 Util (List Utilities)".
- ⑪ **MENU** Opens the "LIST MENU" for processing the individual entries in the selected parts list.  
 see Section "18.1 List Menu".  
 You can also call up the list menu using the  key.
- ⑫ **SELECTED PARTS LIST - Folder** Displays the **name of the folder** in which the selected parts list has been stored. You can choose or redefine the name of the folder using the submenu "UTIL⑩ / SAVE CURRENT PARTS LIST / Choose Folder or Enter "NEW"".  see Section "18.2.1 Save Current List".  
 If a folder has not yet been determined, this is indicated with (None).
- ⑬ **Selected parts list** Displays the **name of the selected parts list**. You can choose or redefine the name of the selected parts list using the submenu "UTIL⑩ / SAVE CURRENT LIST".  see Section "18.2.1 Save Current List".  
 (None) is displayed if you have not assigned a name to the selected parts list yet.
- ⑭ **Order** Opens the "PARTS ORDER" submenu in which you can complete a standard order form.  
 see Section "18.3 Parts Order".

## 18.1 List Menu

You can change the individual entries in the Selected Parts List manually using the functions listed in the "LIST MENU".

You can call up the "LIST MENU" via

- The "MENU" action button
- The **Pos 1** key
- Menu bar "Review List/Menu"

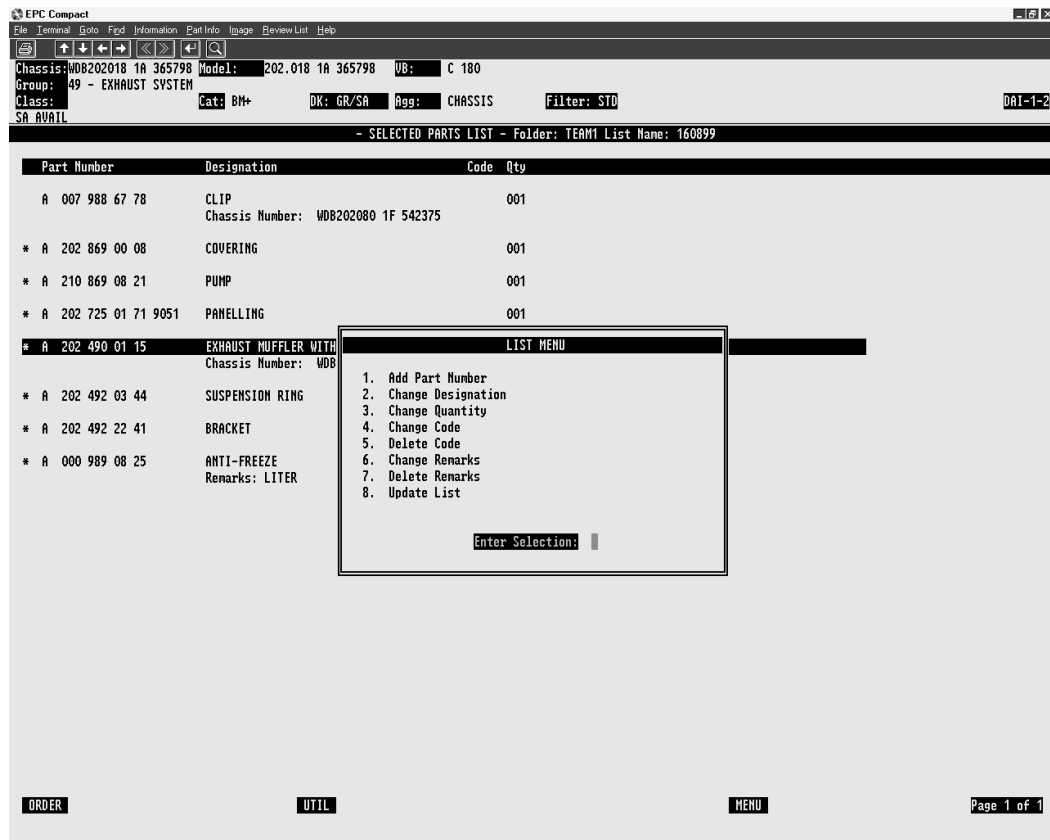

EPC4E093

- 1. Add Part Number** Opens the "Add Part Number" submenu. see Section "18.1.1 Add Part Number".
  - 2. Change Designation** Opens the "Change Designation" submenu. see Section "18.1.2 Change Designation".
  - 3. Change Quantity** Opens the "Change Quantity" submenu. see Section "18.1.3 Change Quantity".
  - 4. Change Code** Opens the Change Code submenu. see Section "18.1.4 Change Code".
  - 5. Delete Code** Opens the "Delete Code" pop-up menu. see Section "18.1.5 Delete Code".
  - 6. Change Remarks** Opens the "Change Remarks" submenu. see Section "18.1.6 Change Remarks".
  - 7. Delete Remarks** Opens the "Delete Remarks" pop-up menu. see Section "18.1.7 Delete Remarks".
  - 8. Update List** Opens the pop-up menu "LISTUPD/Are You Sure You Want To Update The List".  
 see Section "18.1.8 List Update".  
 You can call up the list by clicking the **End** button in the "SELECTED PARTS LIST" screen.
- Enter Selection** For entering the desired item number.  
 You should confirm the entry with **Return**.

### 18.1.1 Add Part Number

You can transfer a new list entry to the selected parts list by entering it "manually" in the "Add Part Number" screen. When you confirm the entry with **Return**, the "Change Quantity" submenu is opened.

 see Section "19.1.1 Add Part Qty".

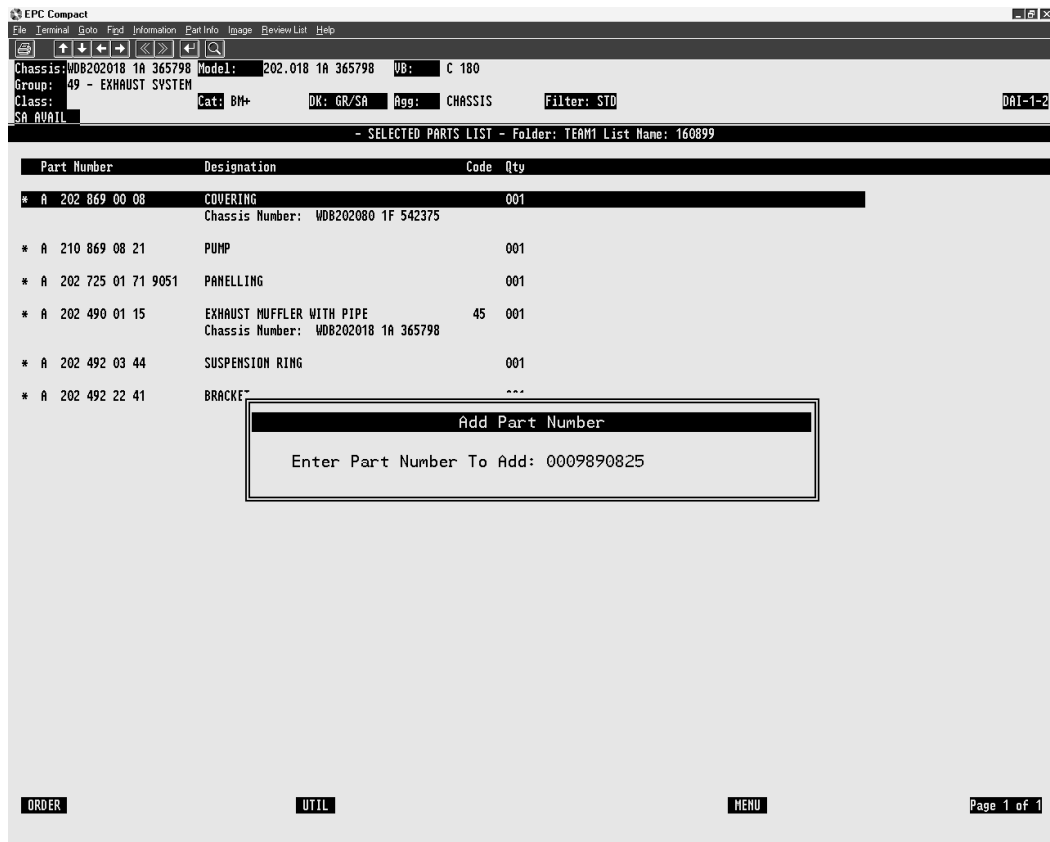

#### Enter Part Number To Add

For **entering** a complete part number (**including** the code letter, also the ES1/ES2 CODES where necessary).

 You must not enter any blanks. The entry is **not** checked.

If you do not enter a code letter, the letter "A" is assigned by default.

When you confirm your entry with **Return**, the "Add Quantity" submenu is opened.

 see Section "18.1.3 Change Quantity".

## 18.1.2 Change Designation

In the "Change Designation" submenu, you can

- rename a "manual" entry which was transferred to the selected parts list using the "Add Part Number" function,
- change the existing name of a part in the "SELECTED PARTS LIST".

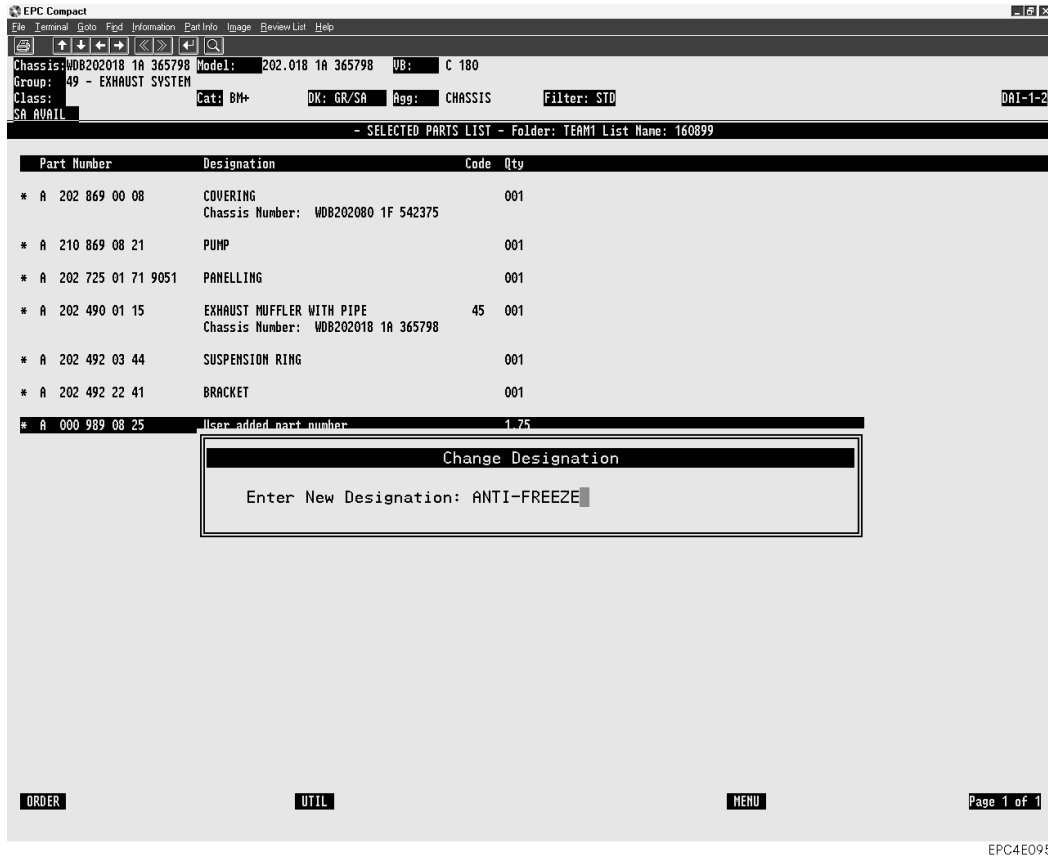

### Enter New Designation

For entering a new designation (maximum 38 characters) for the selected list entry. When you confirm your entry with **Return**, the designation is updated in the "SELECTED PARTS LIST".

### 18.1.3 Change Quantity

You can change the desired quantity of a part in the "SELECTED PARTS LIST" in the "Change Quantity" submenu.

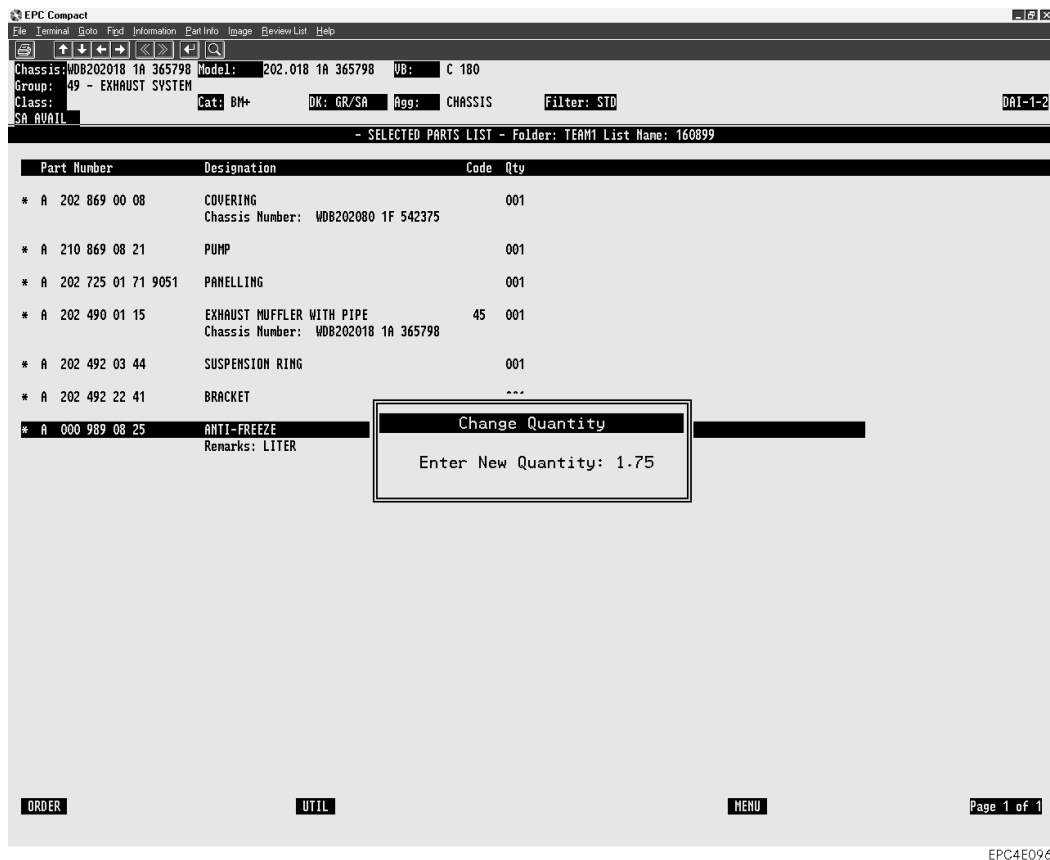

#### Enter New Quantity

For **entering** the desired number of the part selected in the "SELECTED PARTS LIST" (maximum of 5 characters, decimals can have no more than 3 integer positions, one decimal point, and no more than 2 decimal places).

After you have confirmed it with **[Return]**, the appropriate list entry is updated in the "SELECTED PARTS LIST".

### 18.1.4 Change Code

In the "Change Code" submenu, you can

- reassign a grace or guarantee code to a part in the "SELECTED PARTS LIST"
- change the existing guarantee or grace code.

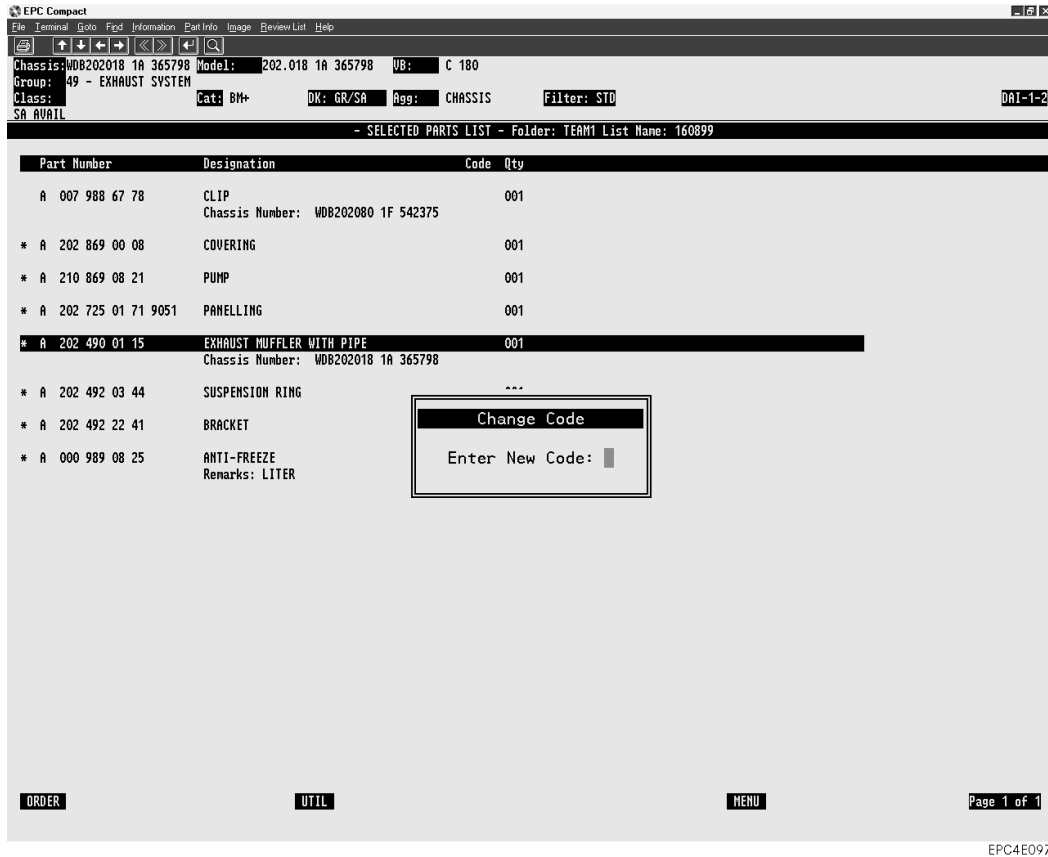

#### Enter New Code

For entering a code for the chosen part.

This code can be freely assigned within the company (maximum of 2 characters, A to Z and 0 to 9).

- 1 After you have entered the code, the "Change Code" submenu is closed automatically and the list entry is updated in the "SELECTED PARTS LIST".

### 18.1.5 Delete Code

You can use the "Delete Code" pop-up menu to delete the code for a selected part in the "SELECTED PARTS LIST".

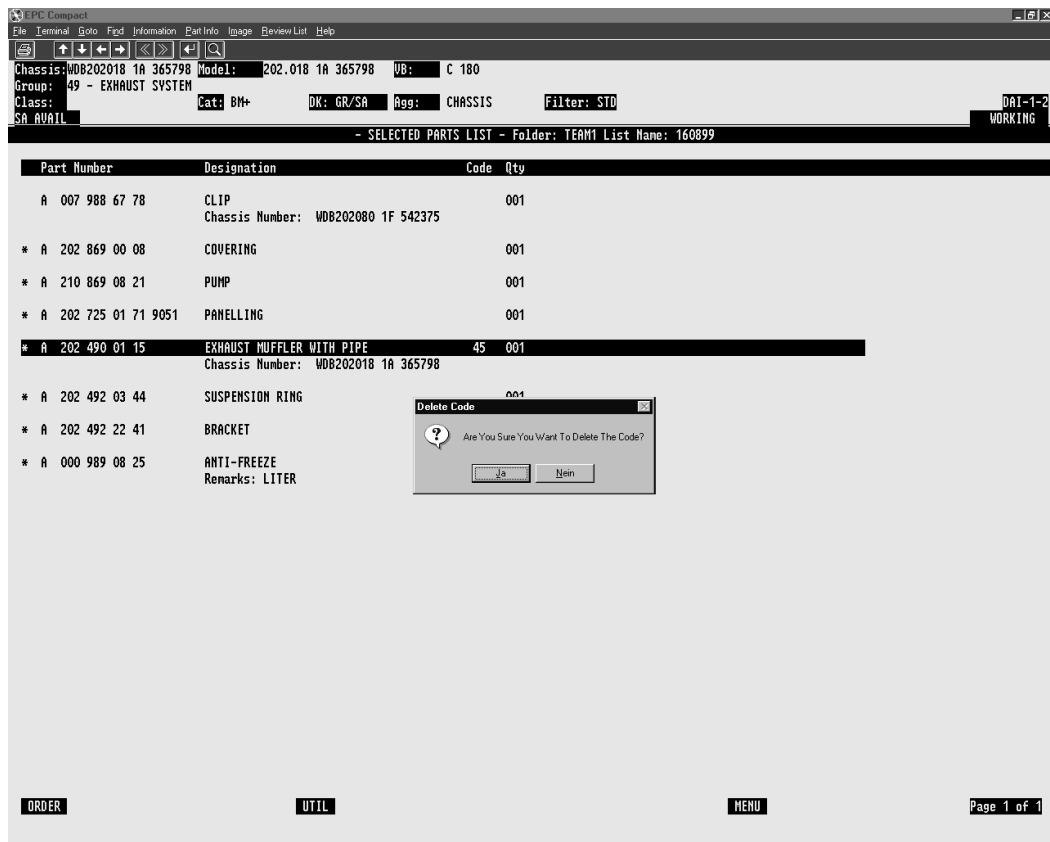

EPC4E098

**Yes** Deletes the code and closes the "Delete Code" pop-up menu.

**No** Closes the "Delete Code" pop-up menu **without** deleting the code.

## 18.1.6 Change Remarks

In the "Change Remarks" submenu, you can

- assign a new remark to a part or
- change an existing remark.

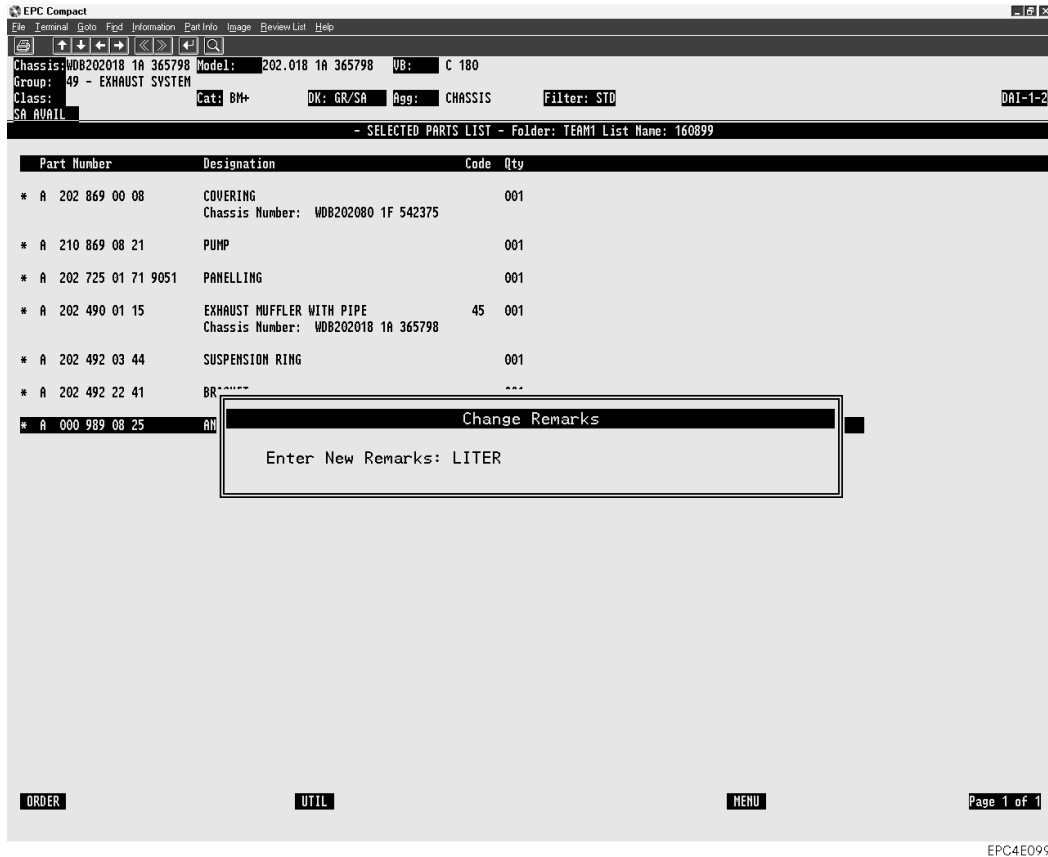

**Enter New Remarks** For entering or modifying remarks (maximum 37 characters) for the selected list entry.

- i** After you have confirmed it with **Return**, the list entry is updated in the "SELECTED PARTS LIST".

### 18.1.7 Delete Remarks

In the "Delete Remarks" pop-up menu, you can delete a remark that you entered manually for a selected part in the "SELECTED PARTS LIST".

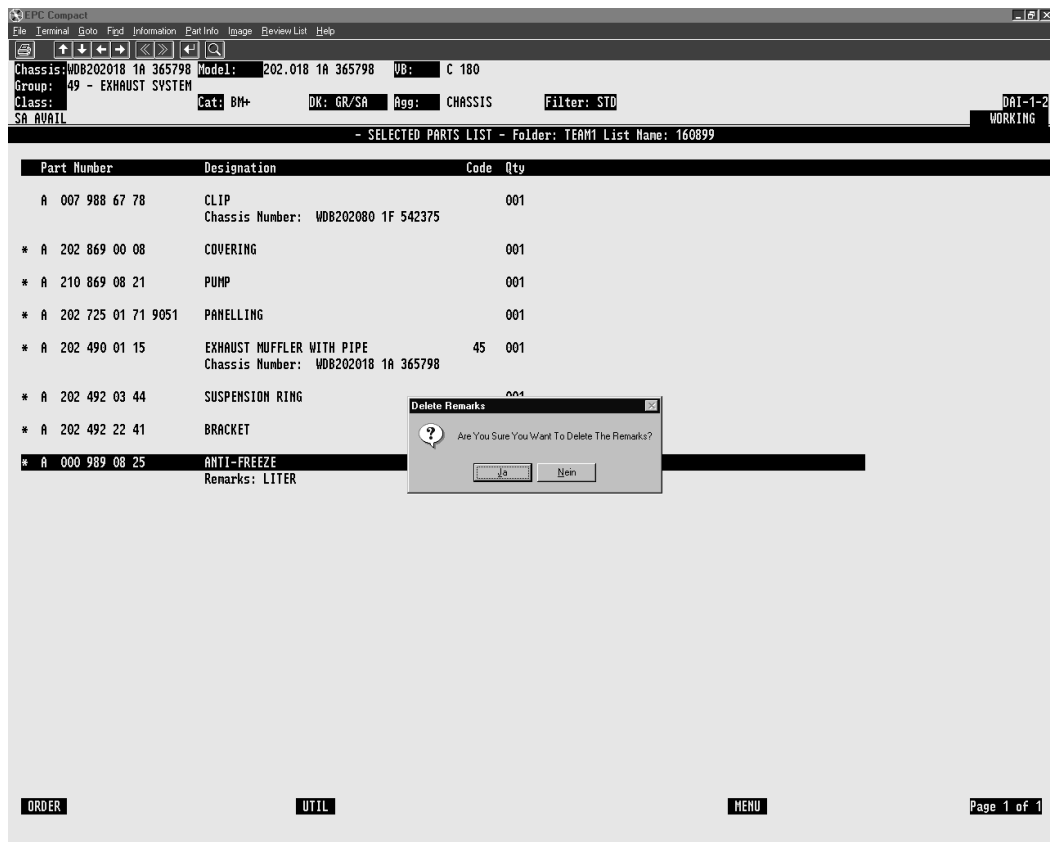

EPC4E100

**Yes** Deletes the remark and closes the "Delete Remarks" pop-up menu.

**No** Closes the "Delete Remarks" pop-up menu **without** deleting the remark.

### 18.1.8 List Update

List entries without a star "\*" are deleted from the "SELECTED PARTS LIST" using "LISTUPD".

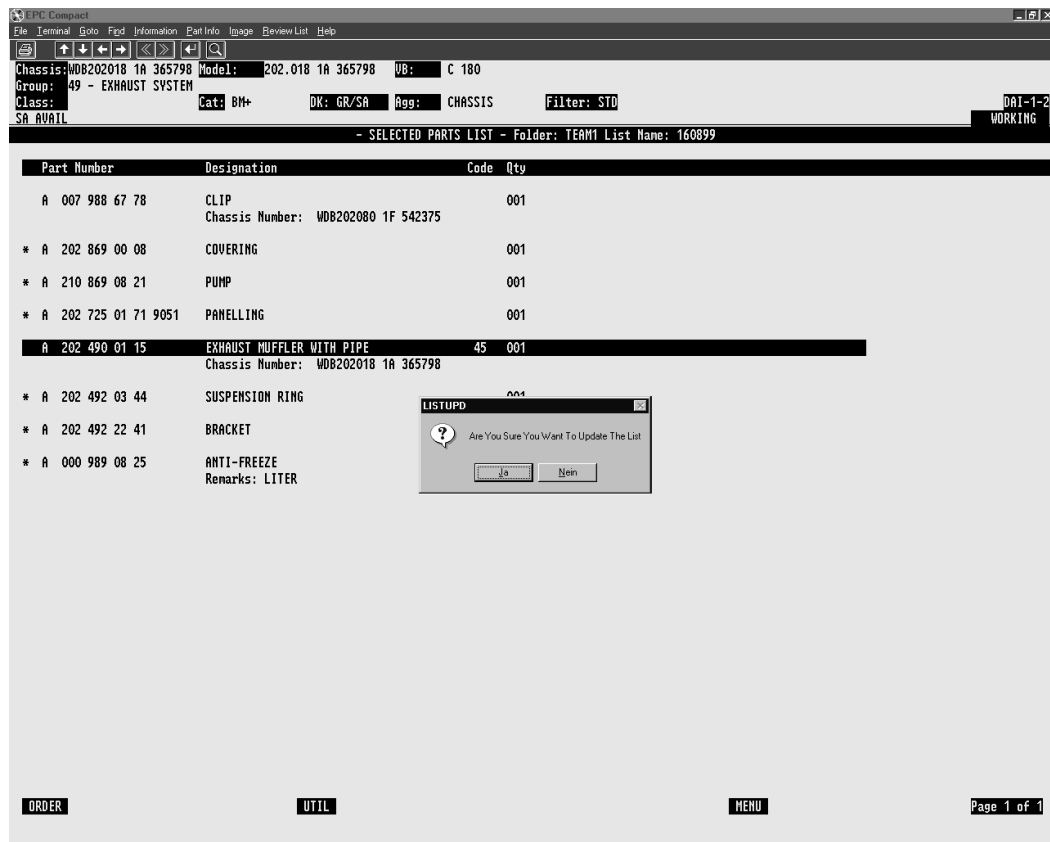

EPC4E101

**Yes** Updates the "SELECTED PARTS LIST" and closes the "LISTUPD" pop-up menu.

**No** Closes the "LISTUPD" pop-up menu **without** updating the "SELECTED PARTS LIST".

## 18.2 Util (List Utilities)



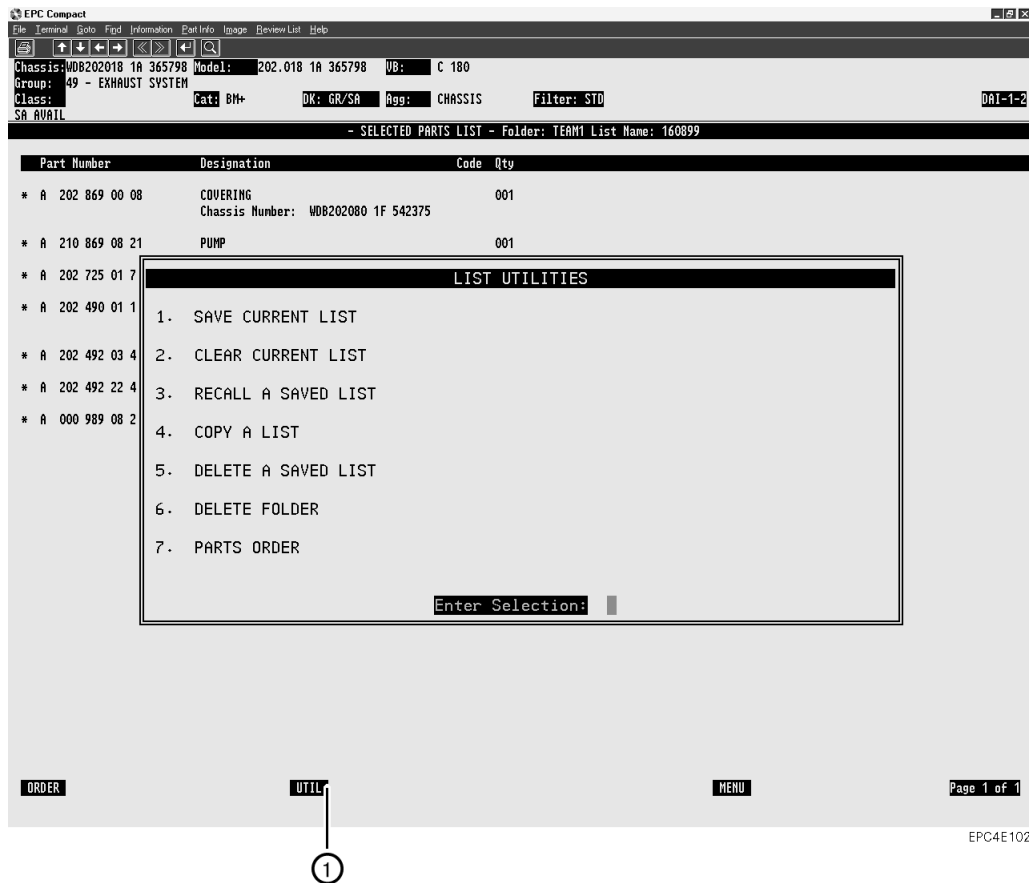

The selected parts lists and the higher-level folders are administrated in the "LIST UTILITIES" submenu.

- You can save selected parts lists.
- You can create a blank selected parts list.
- You can call up, copy, delete the saved "SELECTED PARTS LISTS" at any time.
- You can create new folders.
- You can delete folders together with the selected parts lists saved in them.





① **UTIL** Opens the "LIST UTILITIES" submenu for administering the selected parts lists (e. g. saving, copying, deleting).

- 1. SAVE CURRENT LIST** Opens the "Choose Folder or Enter "NEW"" submenu.  
A selected parts list can be saved to
- an **existing** folder or
  - a **new** folder.
- 📖 see Section "18.2.1.1 Save Current List to an Existing Folder"  
📖 see Section "18.2.1.2 Save Current List to a New Folder".
- 📌 If the current "SELECTED PARTS LIST" is empty, the message "No items in shop list" appears in the EPC message line. This means that it is impossible to save a selected parts list.
- 2. CLEAR CURRENT LIST** Opens the "Clear Current List" pop-up menu.  
📖 see Section "18.2.2 Clear Current List".
- 3. RECALL A SAVED LIST** Opens the "Choose Folder or Enter "NEW"" submenu.  
📖 see Section "18.2.3 Recall a Saved List".
- 4. COPY A LIST** Opens the "Choose Folder to copy from" submenu.  
📖 see Section "18.2.4 Copy a List".

- 5. DELETE A SAVED LIST** Opens the "Choose Folder and Enter" submenu.  
 see Section "18.2.5 Delete a Saved List".
- 6. DELETE FOLDER** Opens the "Delete Folder" submenu.  
 see Section "18.2.6 Delete Folder".
- 7. PARTS ORDER** Opens the "PARTS ORDER" submenu in which you can complete a standard order form.  
 see Section "18.3 Parts Order".
- Enter Selection** For entering the desired item number e.g. 1.  
 Confirm your entry with **Return**.

## 18.2.1 Save Current List

A selected parts list is always saved in a folder. A distinction is made between

- saving to an **existing** folder,  
 see Section "18.2.1.1 Save Current List to an Existing Folder".
- saving to a **new** folder.  
 see Section "18.2.1.2 Save Current List to a New Folder"

### 18.2.1.1 Save Current List to an Existing Folder

You can save selected parts lists to an existing folder.

-  Generally speaking, when you install EPC-Compact, a folder is created automatically with the name of the workstation ②. This folder **cannot** be deleted.
- All folders, except for the "workstation folder" ②, are protected with a password.

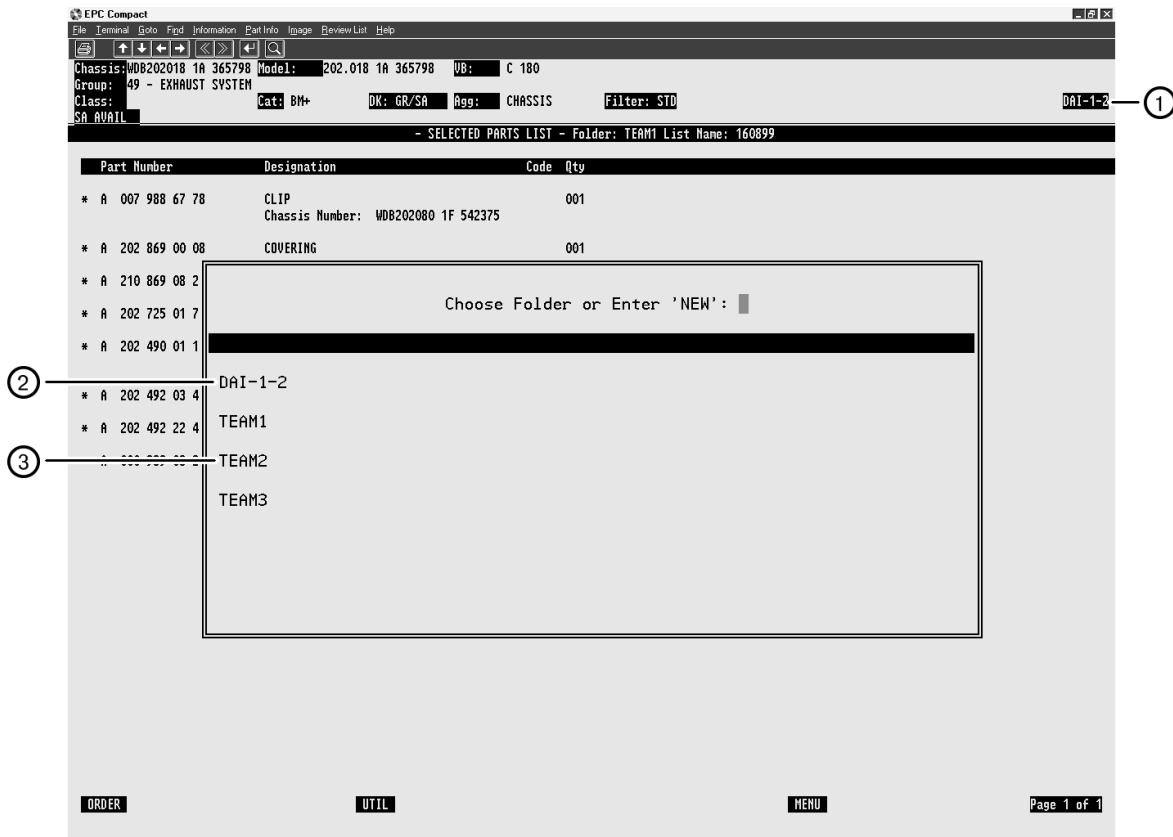

- ① **Workstation name**      Name of the workstation.
- ② **Workstation folder**      Generally speaking, when you install EPC-Compact, a folder with the name of the workstation is created automatically.  
    *i* This folder **cannot** be deleted.
- ③ **Folder name**      After selecting the desired folder, the "SAVE CURRENT LIST" submenu is opened.

*i* **As the procedure is menu-based and self-explanatory, a visual illustration is not provided.**

**"SAVE CURRENT LIST" to an existing folder**

- Click the "UTIL" action button in the selected parts list.
- Select "SAVE CURRENT LIST" in the "LIST UTILITIES" submenu.
- Select the desired folder.
- Confirm password (if necessary).
- Enter the name of the selected parts list in the "SAVE CURRENT LIST" submenu.

### 18.2.1.2 Save Current List to a New Folder

Selected parts lists can be saved to a newly created folder. Users can create as many folders as they want.

- i** All folders, except for the workstation folder ②, are protected with a password.

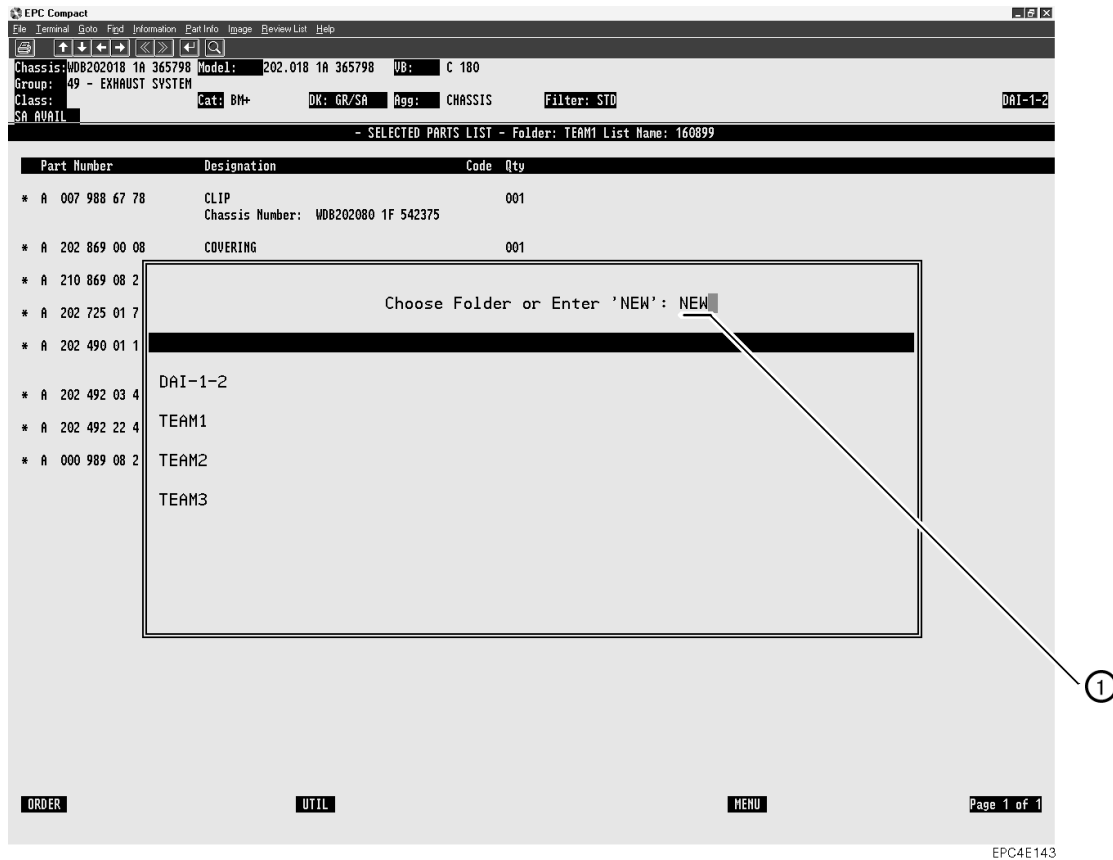

- ① **NEW** After you have entered **NEW** in the input field and confirmed with **Return**, the "New Folder" submenu is opened.

- i** As the procedure is menu-based and self-explanatory, a visual illustration is not provided.

#### "SAVE CURRENT LIST" to a new folder:

- Select the "UTIL" action button in the selected parts list.
  - Select "SAVE CURRENT LIST" in the "LIST UTILS" submenu.
  - Enter the letters "NEW" in the input field ① and confirm with **Return**.
  - Enter a new folder name in the "New Folder" submenu (alphanumeric, maximum 15 characters), confirm the entry with **Return**.
  - Enter a password for the folder in the "New Password" submenu (alphanumeric, maximum 10 characters), confirm the entry with **Return**.  
Enter the password again to confirm it and press **Return**.
  - i** The password is a means of protecting access.
  - Enter the name of the selected parts list in the "SAVE CURRENT LIST" submenu (alphanumeric, maximum 15 characters) and confirm with **Return**.
- ⇒ The selected parts list is saved to the newly created folder. The selected parts list displays the folder name and selected parts list name.

## 18.2.2 Clear Current List

The "CLEAR CURRENT LIST" function creates a new, empty selected parts list.

- The empty selected parts list is identified by the folder and selected parts list name "None".
- With a selected parts list that has already been **saved**, the saved entries are kept and the selected parts list can be called up again at any time.  see Section "18.2.3 Recall a Saved List".
- If the current "SELECTED PARTS LIST" is empty, "Parts information empty" appears in the EPC message line after you call up the "CLEAR CURRENT LIST" function.



**As the procedure is menu-based and self-explanatory, a visual illustration not provided.**

### Clear Current List

- Select the "UTIL" action button in the selected parts list.
  - Select "2. CLEAR CURRENT LIST" in the "LIST UTILITIES" submenu.
  - Confirm the "CLEAR CURRENT LIST" pop-up menu with "Yes".
- ⇒ A new, empty selected parts list with folder name and selected parts list name "None" is created.

## 18.2.3 Recall a Saved List

You can call up a saved selected parts list for further processing using the "RECALL A SAVED LIST" function.



**As the procedure is menu-based and self-explanatory, a visual illustration is not provided.**

### Recalling a saved list:

- Select the "UTIL" action button in the selected parts list.
  - Select "3. RECALL A SAVED LIST" in the "LIST UTILITIES" submenu.
  - Select the desired folder in the "Choose Folder or Enter" submenu.
  - Select the desired selected parts folder in the "Choose selected parts list or enter" submenu.
  - Overwrite the "Overwrite Current List" pop-up menu and confirm it with "Yes".
- ⇒ The saved selected parts list is called up.

## 18.2.4 Copy a List



You can copy a saved selected parts list with "COPY A LIST".

After a copy procedure, the parts list is **not** displayed automatically but must be called up via "UTIL/3 RECALL A SAVED LIST".



**As the procedure is menu-based and self-explanatory, a visual illustration is not provided.**

### Copy a list:

- Select the "UTIL" action button in the selected parts list.
  - Select "4. COPY A LIST" in the "LIST UTILITIES" submenu.
  - Select the source folder of the parts list to be copied in the "Choose Source Folder or Enter" submenu.
  - Select the selected parts list to be copied in the "Select parts to be copied" submenu.
  - Assign a new name to the copy of the parts list in the "COPY A LIST" submenu and confirm the entry with .
  - In the "Choose Folder or Enter "NEW"" submenu, choose the existing folder or create a new folder to save the parts list.  see Section "18.2.1.2 Save Current List to a New Folder".
  - Carry out "Password Confirmation", if necessary.
- ⇒ The parts list has been copied and is stored in the target folder with the new name.



You can call up the copied parts list via the "3. RECALL A SAVED LIST" function.

 see Section "18.2.3 Recall a Saved List".

### 18.2.5 Delete a Saved List

With "DELETE A SAVED LIST" you can delete a selected parts list from a folder.

**i** As the procedure is menu-based and self-explanatory, a visual illustration is not provided.

#### DELETE A SAVED LIST:

- Click the "UTIL" action button in the parts list.
- Select "5. DELETE A SAVED LIST" in the "LIST UTILITIES" submenu.
- Select the parts list to be deleted in the "Choose/enter folder" submenu.
- Enter the folder password in the "Password Confirmation" submenu and confirm the entry with **Return**.
- Select the parts list to be deleted in the "Choose/enter parts list" submenu.
- Confirm "Delete List Confirmation" submenu with "Yes".
- ⇒ The parts list has been deleted.

### 18.2.6 Delete Folder

With the "DELETE FOLDER" function, you can delete a folder together with all the parts lists stored within it. You can delete all folders, except for the "Workstation Folder".

**i** As the procedure is menu-based and self-explanatory, a visual illustration is not provided.

#### Deleting folder:

- Select the "UTIL" action button in the parts list.
- Select "6. DELETE FOLDER" in the "LIST UTILITIES" submenu.
- Select the folder to be deleted in the "DELETE FOLDER" submenu.
- Enter the password of the folder to be deleted in the "Password Confirmation" submenu and confirm your entry with **Return**.
- Confirm the "DELETE FOLDER" pop-up menu with "Yes".
- ⇒ The parts list folder is deleted.
- Close the "DELETE FOLDER" submenu with the right mouse button.

### 18.3 Parts Order

The "PARTS ORDER" is a standard order form. The "PARTS ORDER" can be

- stored as a file,
- copied to the clipboard and processed further with any word processing program,
- printed out and sent by fax, for example.

The "PARTS ORDER" can only be called up from the "SELECTED PARTS LIST" via

- the "ORDER" action button or
- the "UTIL" action button, 7th parts order.

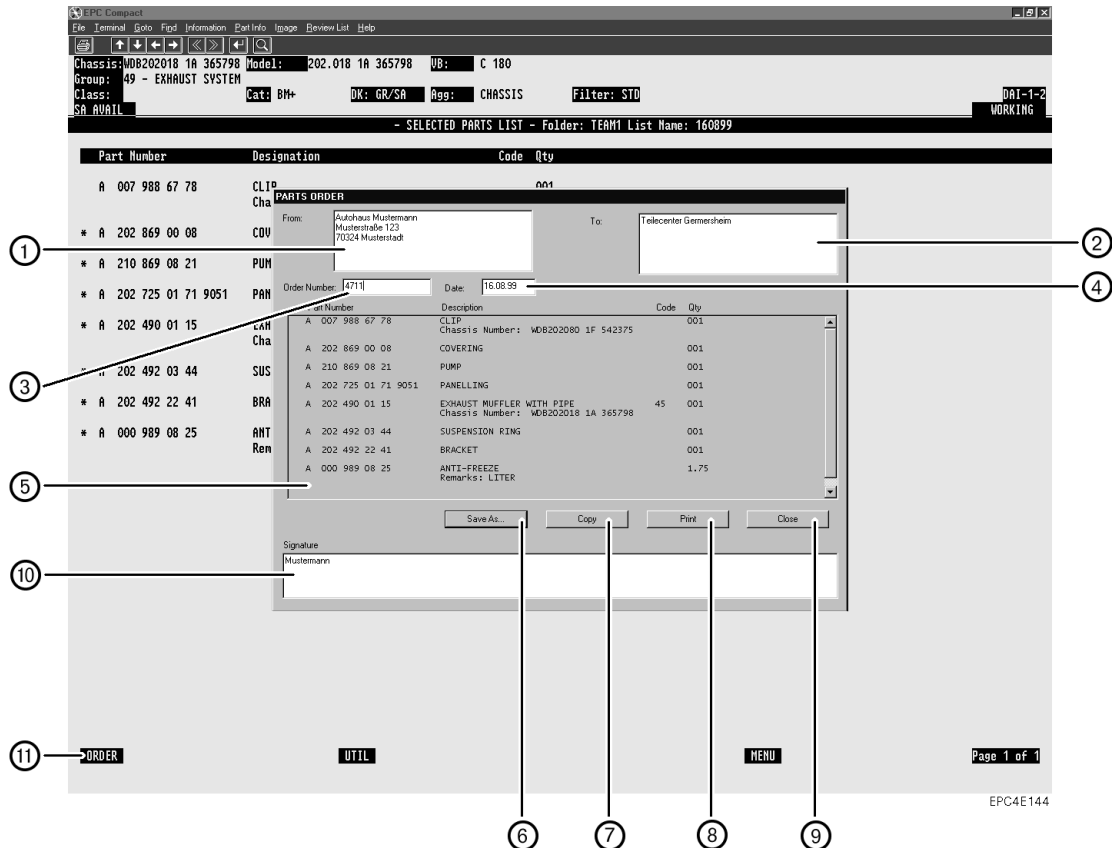

- From** For entering details on the customer (e. g. name, address, ...).  
 The last entry you make is stored until you overwrite it.
- To** For entering details on the supplier (e.g. name, address, ...).  
 The last entry you make is stored until you overwrite it.
- Order number** For entering an individual order number (alphanumeric, maximum 50 characters).
- Date** The current date is entered automatically after you call up the "PARTS ORDER". Each individual date can be overwritten.
- Order List** Contains the parts to be ordered along with part numbers, description, code and quantity.
- Save As** Opens the "Save As" menu in which you can specify a file name. The file *prtorders.txt* is created by default when the system is installed. Generally, this file can be overwritten or new files can be generated.  
 The files are stored as *C:\BHROOT\orders*.
- Copy** Copies the parts order to the clipboard. The texts can be processed further in Windows programs.

- ⑧ **Print** Opens the "Print" submenu.  see Section "[21 Printing](#)".
- ⑨ **Close** Closes the "PARTS ORDER" and returns to the "SELECTED PARTS LIST".
- ⑩ **Signature** For entering information such as
- Name,
  - E-Mail address,
  - ...
- ⑪ **ORDER** Opens the "PARTS ORDER" submenu in which you can complete a standard order form.

## 19 Add

Depending on the screen in which you are working, you can use the "Add" function to call up one of the following submenus:

- "Add Part Number".  see Section "19.1 Add Part Number".
- "ES CODE INPUT"  see Section "19.2 ES Code Input (only possible in the parts information)".

### 19.1 Add Part Number

You can use the "Add" function to call up the "Add Part Number" submenu from almost every screen in the EPC. Here, you can enter a part number, which is then copied directly to the "SELECTED PARTS LIST" with the star (\*).

 see Section "18 Selected Parts List".

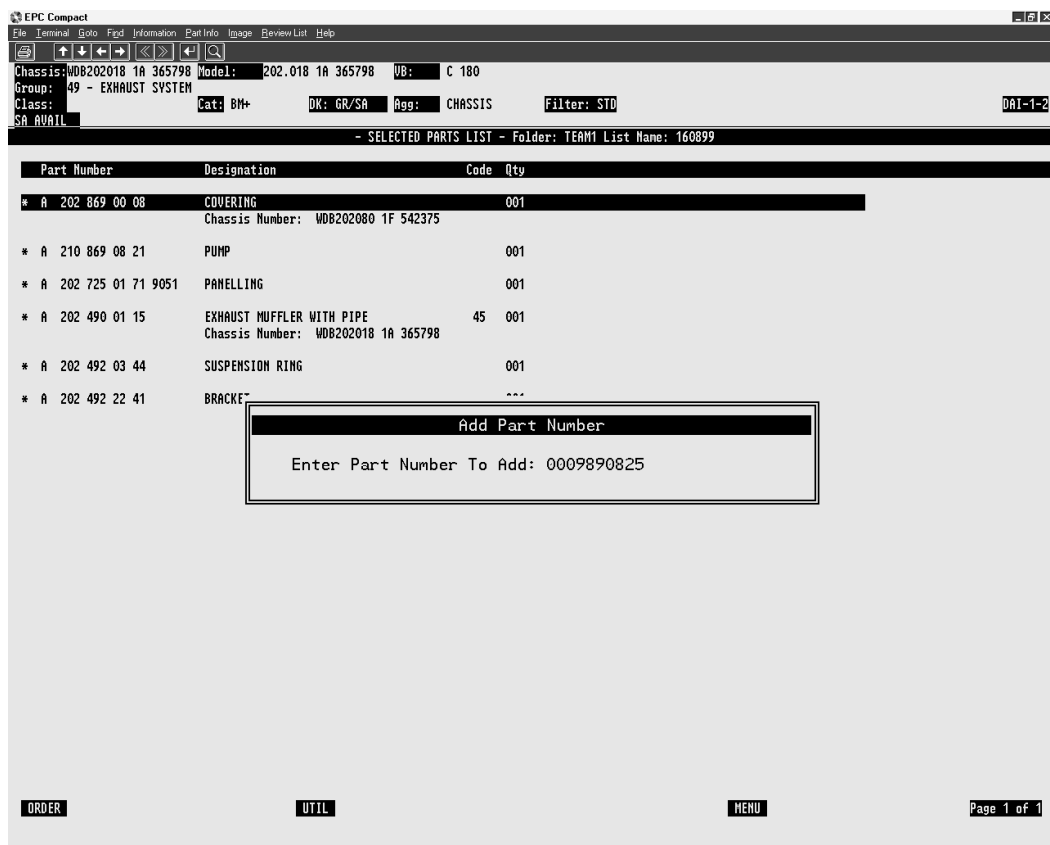

#### Enter Part Number

For **entering** a complete part number (**including** the code letter, possibly also the ES1/ES2 CODE). After you have confirmed the entry with R, the "Add Part Qty" submenu is opened.

 see Section "19.1.1 Add Part Qty".

-  You must enter the part number without blanks. The input is **not** checked. If you do not enter a code letter, the letter "A" is assigned by default.

#### The following code letters (KB) are available at present:



- A Design part number (MB)
- N Standard part number
- W Tool part number
- B6 Accessories part number
- HWA AMG part number
- Q Supplier number



- Select "Review List/Add Parts" in the menu bar
- ⇒ "Add Part Number" is called up.

### 19.1.1 Add Part Qty

In the "Add Part Qty" submenu, you specify the desired quantity for the part number you have entered. The "Add Part Qty" submenu can be called up from the following submenus:

- "Add Part Number".  see Section "19.1 Add Part Number".
- "ES CODE INPUT" (only from the "Parts Information" screen).  
 see Section "19.2 ES Code Input (only possible in the parts information)".

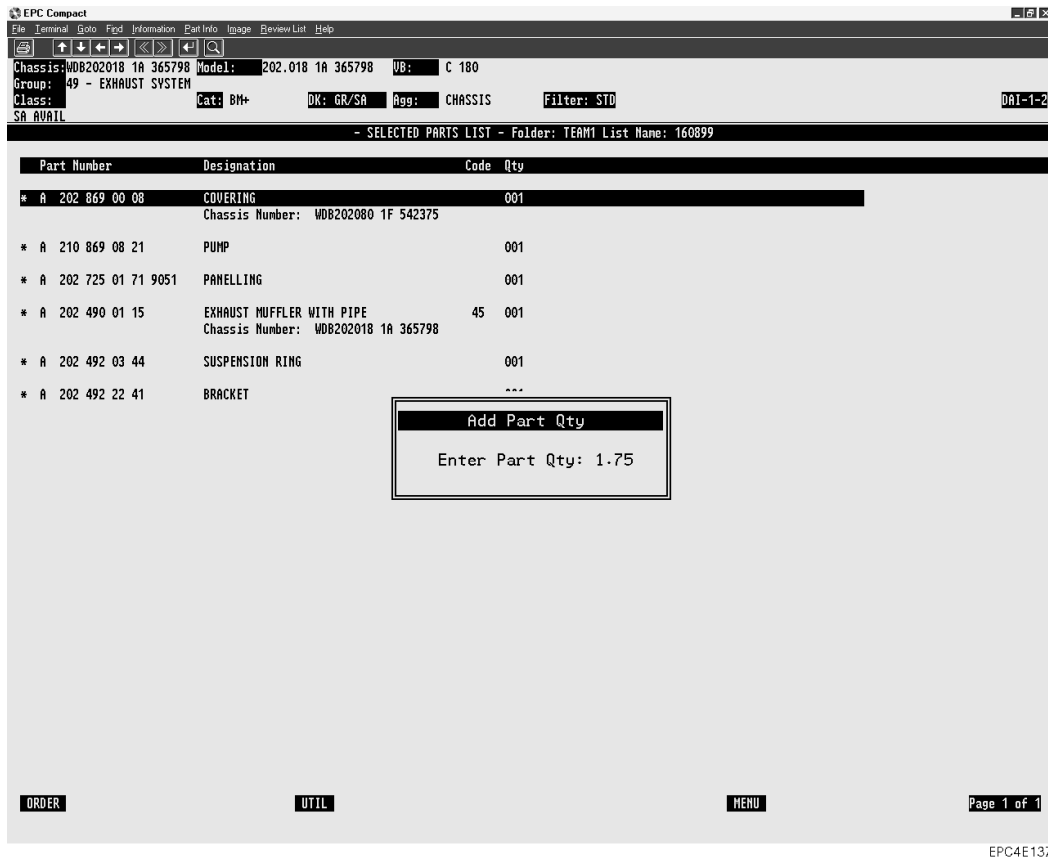

EPC4E137

#### Enter Part Qty

For **entering** the desired part quantity. The quantity you specify is entered in the "SELECTED PARTS LIST".  see Section "18 Selected Parts List".

 The quantity must be greater than "0" with a maximum of 5 characters, (max. 3 integer positions, one decimal point, and no more than 2 decimal places.

If the processed parts number is already contained in the "SELECTED PARTS LIST," the "Duplicate Part" submenu is opened.  see Section "17.4 Duplicate Part".

## 19.2 ES Code Input (only possible in the parts information)

In the "ES CODE INPUT" submenu, you can add an ES Code (supplementary code) to a selected part number in the parts information. The supplementary code designates certain features (e. g. paint, material, leather, ...).



The "ES CODE INPUT" submenu can only be called up from the "Parts Information" screen.

To determine the correct supplementary code (ES1/ES2 CODE), you require information from the "data card".

For parts information see Section "17 Parts Information/SA Parts Information".

For data card see Section "7 Data Card".

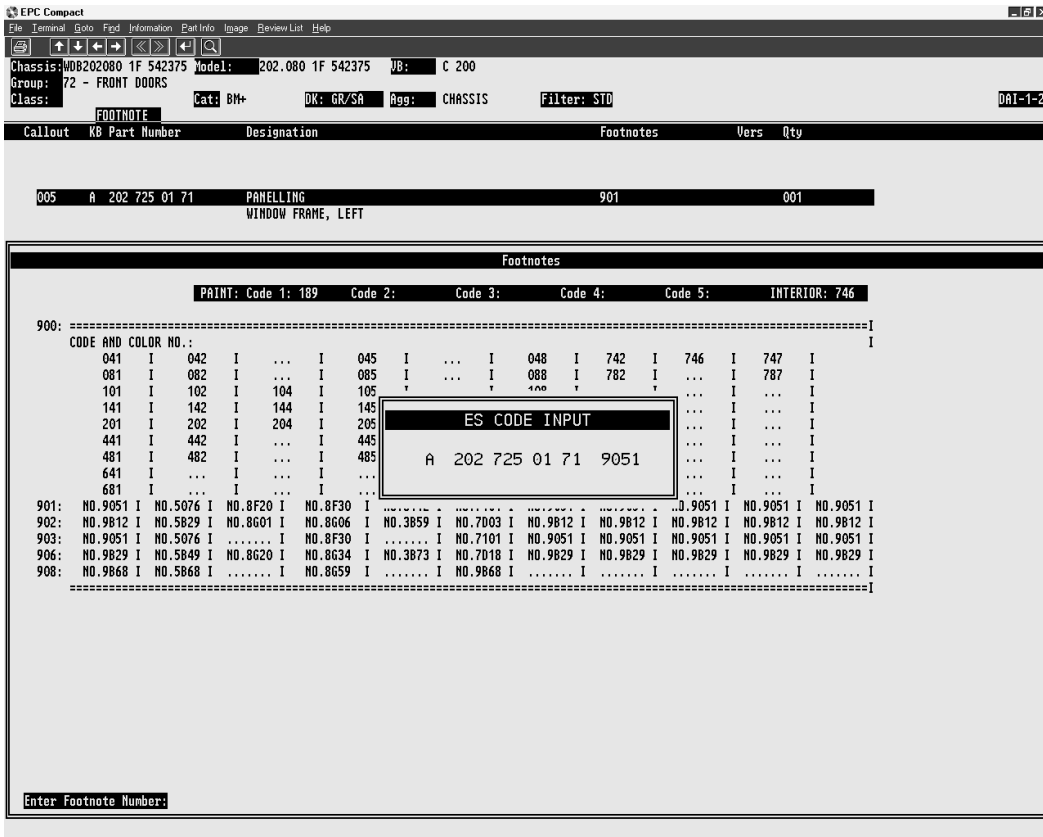

EPC4E136

### ES CODE INPUT

For **entering** the ES1 or ES2 Code (supplementary code for a part number).

After you have confirmed the entry with , the "Add Part Qty" submenu is opened.

see Section "19.1.1 Add Part Qty".

You can enter a maximum of 6 characters. No blanks are allowed. The input is not checked.

## 20 Displaying Images/Text

To check part numbers on the screen using the illustrated page and without having to leave the current parts information or selected parts list, you can show or hide the illustrated page that you edited last.

**i** You **cannot** choose a screen item.

The screenshot shows the EPC Compact software interface. The top menu bar includes File, Item, Edit, Fgnd, Information, Part Info, Image, Review List, and Help. The status bar displays: Chassis: WDB202080 1F 542375, Model: 202.080 1F 542375, UB: C 200, Group: 72 - FRONT DOORS, Class: , Cat: BW+, DK: GR/SA, Agg: CHASSIS, Filter: STD, and DAI-1-2.

The main window is divided into two sections. On the left is a table with columns 'Callout', 'KB', and 'Part Number'. On the right is an exploded view diagram of a car door assembly with various parts numbered. Callout 1 points to the diagram, and callout 2 points to the table.

Callout	KB	Part Number
005	A	202 720 07 05
005	A	202 720 15 05
005	A	202 720 08 05
005	A	202 720 16 05
008	A	202 720 01 09
008	A	202 720 02 09
009	A	202 723 03 14
009	A	202 723 04 14
011	A	202 720 00 37

RIGHT

BRACKET LEFT, TO A202 720 07 05 INTERIOR HANDLE ASSEMBLY PULL ROD	046	001
BRACKET RIGHT, TO A202 720 08 05 INTERIOR HANDLE ASSEMBLY PULL ROD	046	001
HINGE		004

Page 1 of 5

① **Illustrated page** Illustrated page edited last.

② **Parts information or selected parts list** Parts information or selected parts list currently being edited.



### Hiding/Showing Illustrated Pages

- Select "Image/Image Text F12" in the menu bar
- ⇒ The illustrated page that you edited last is shown or hidden.





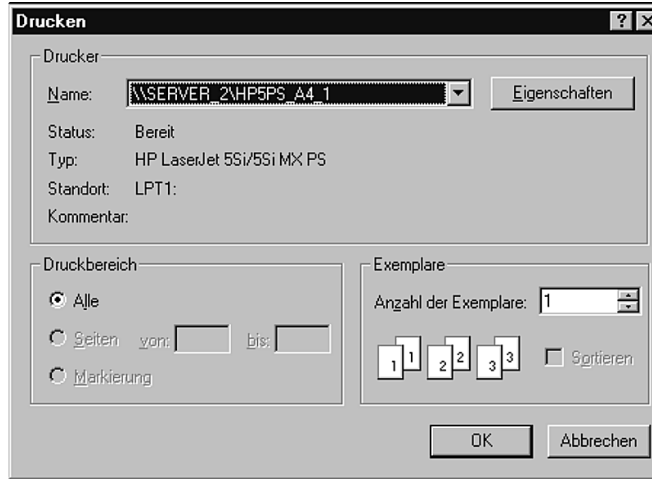

## 21 Printing

In the EPC, the screen contents, images, and lists (selected parts lists, parts information, data card, parts order) can be printed if required.

-  The "Print" submenu contains the standard Windows options.



EPC1S009

- 
  - In the "Data Card" and "SELECTED PARTS LIST", the entire contents (all pages) are printed, in other words the contents not visible on the screen are also printed.
    -  see Section "18 Selected Parts List".
    -  see Section "7 Data Card".
  - Images are only printed if the following functions are called up via the menu bar:
    - "Image/Image Text F12"  see Section "20 Displaying Images/Text".
    - "Image/Zoom"  see Section "16.1 Enlarging Illustrated Pages".
  - You can create a 1:1 printout of the screen contents (hardcopy) using the  key.
  - If you choose "File/Print" in the **menu bar**, only the contents on the screen are printed out, except in the "Datocard" and "SELECTED PARTS LIST" screens.
  - If you choose "File/Print window" in the **menu bar**, only the contents displayed in the EPC window are printed.
  - You can create a 1:1 printout of the screen contents (hardcopy) by choosing "File/Print screen" in the menu bar.
  - You can call up the "Print Setup" submenu by choosing "Print/Page setup" in the **menu bar**. This enables you to define the familiar print settings in Windows.



- Click the printer icon in the toolbar.  
or
- Choose "File/Print" in the menu bar.
- ⇒ The "Print" submenu is displayed.

## 22 SYSX Menu

When you choose "File/Exit" in the menu bar in conjunction with a selected parts list that has **not** yet been saved, a confirmation prompt appears preventing you from exiting the EPC inadvertently without saving the current "SELECTED PARTS LIST" beforehand.

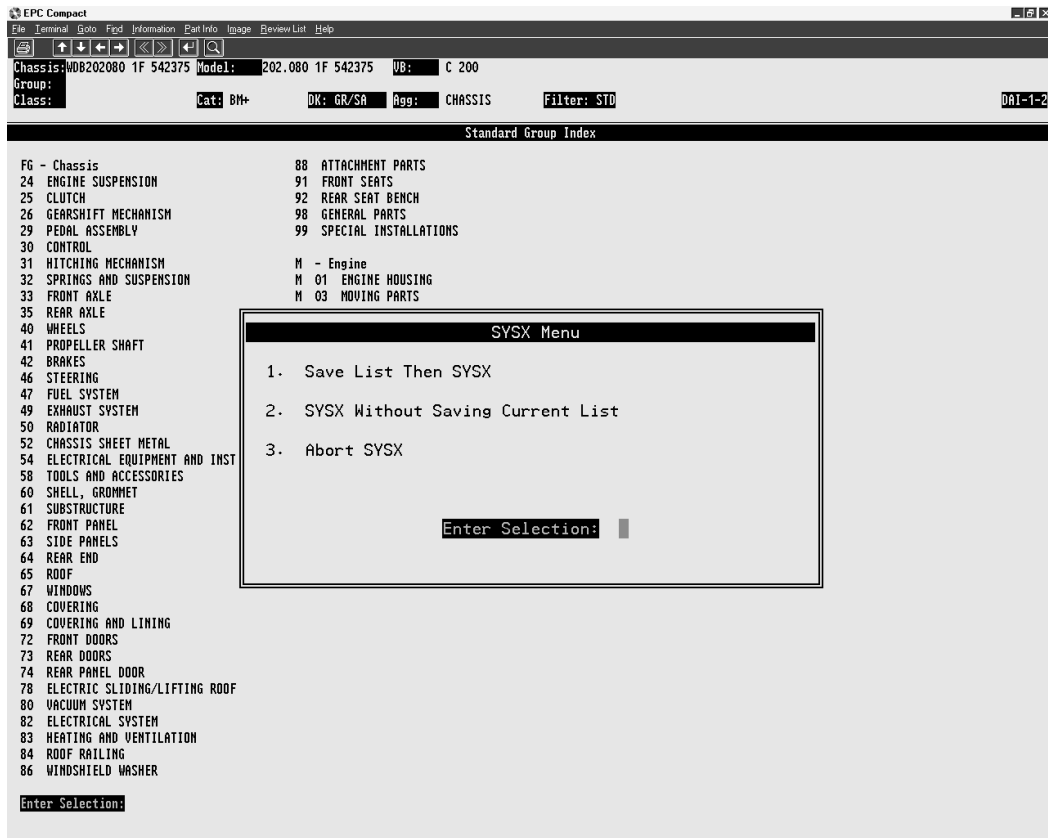

EPC4E135

1. **Save List Then SYSX** Saves the "selected parts list". Opens the "Choose Folder or Enter "NEW"" submenu.  see Section "18.2.1 Save Current List".
  2. **SYSX Without Saving Current List** You exit EPC-Compact without saving the "selected parts list".
  3. **Abort SYSX** Aborts the procedure and closes the "SYSX Menu" without saving the "selected parts list".
- Enter Selection** For entering the chosen list entry.

### 23 DBCP Configuration

You can use "DBCP Configuration" to make default settings for the workstation.

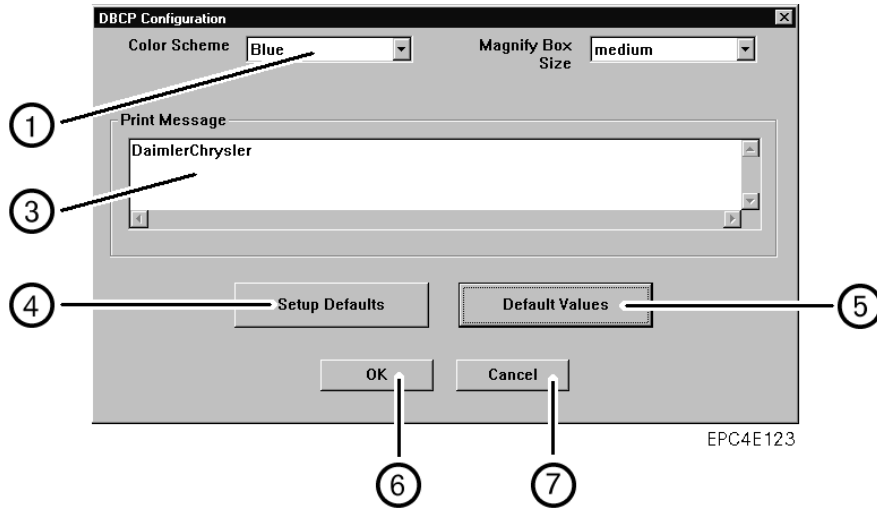

- ① **Color Scheme** For choosing a background color.
- ② **Magnify Box Size** For setting the zoom function in illustrated pages. You can set the magnify box to three different sizes. see Section "16 Illustrated Page".
- ③ **Print Message** For defining default settings for the footer text in printed lists (selected parts list, parts information, data card). see Section "21 Printing".  
 ⓘ The footer text is only printed if the print job was initiated via "File/Print" in the menu bar.
- ④ **Setup Defaults** No function.
- ⑤ **Default Values** Restores the default settings (e. g. blue background screen).
- ⑥ **OK** Closes the "DBCP Configuration" window, **and saves** the changed settings.
- ⑦ **Cancel** Closes the "DBCP Configuration" window, **without** saving the settings.



- Choose "File/Settings" in the menu bar.
- ⇒ "DBCP Configuration" is called up.

## 24 Application Index

You can call up the application index via "Goto/Configuration" in the menu bar. This provides you with access to the following functions:

- Shop Materials
- About DB EPC (details on the version, copyright information)

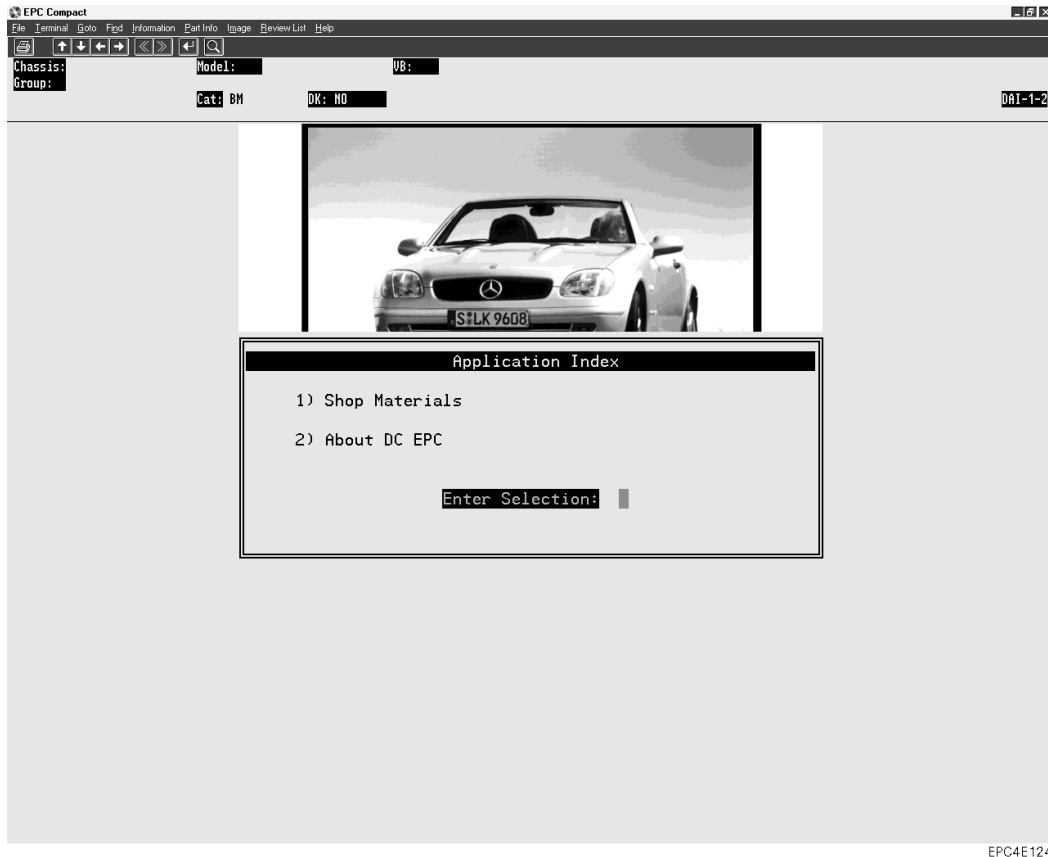

### 1. Shop Materials

Calls up the class index for determining the "Shop Materials" for the cars or trucks division.  see Section ["24.1 Shop Materials \(Class Index\)"](#).

Once you define the class, the "Shop Materials" group index is called up.

 see Section ["24.1 Shop Materials \(Class Index\)"](#).

### 2. About DC EPC

Calls up copyright information.

 see Section ["24.2 About DC EPC"](#).

## 24.1 Shop Materials (Class Index)

The "shop materials" are subdivided into the classes "cars" and "trucks". Once you select the class, the "Shop Material Group Index" is called up.  see Section "24.1.1 Shop Material Group Index".



**List entry**                      For **selecting** the class (e. g. 1 car).

**Enter Selection:**              For **entering** the class number (e. g. 1 for car).

### 24.1.1 Shop Material Group Index

Irrespective of the vehicle you have selected, the "Shop Material Group Index" offers the following materials:

- Varnish
- Car care articles
- Upholstery materials (upholstery material, leather, floor covering, ...)
- Other articles (preservatives, antifreeze, ...)

 The "Shop Material Group Index" is **not** connected to the "Group Index" and is not assigned to any catalogue.

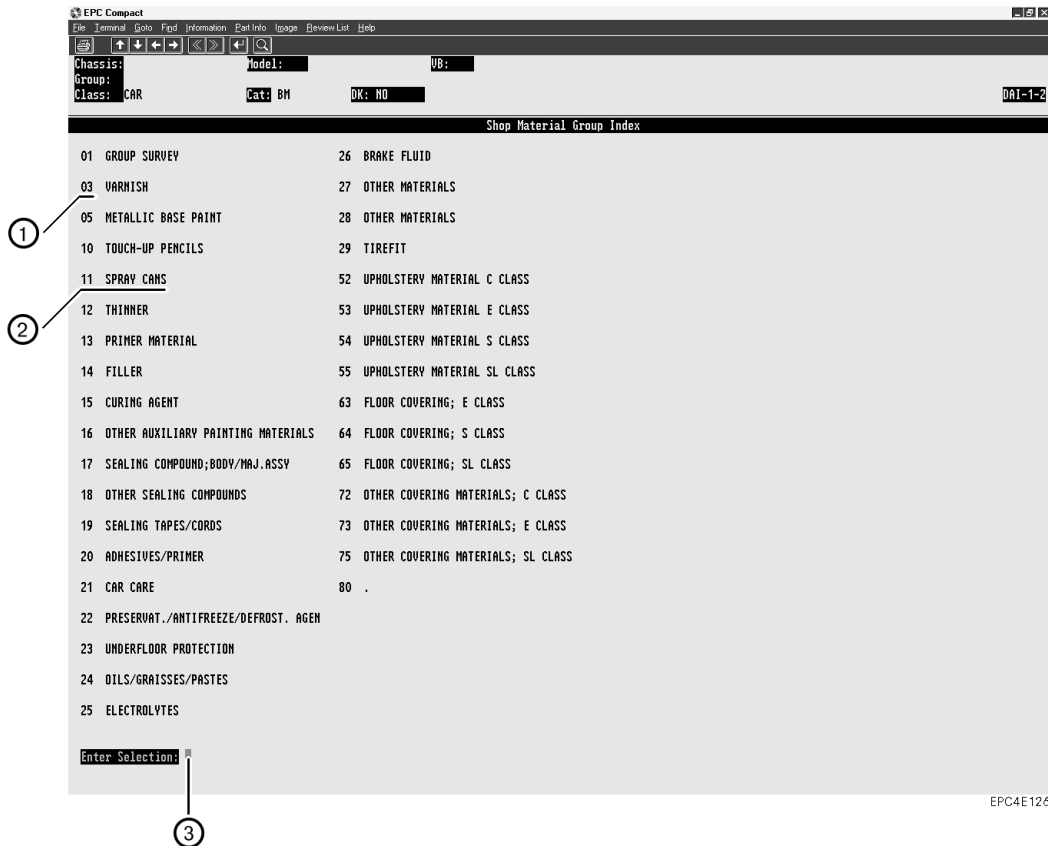

- ① **Group no.** The group number assigned to the group designation (e.g. 10).
- ② **List entry** **For selecting** the desired group entry (e.g. 12 THINNER).
- ③ **Enter Selection** For entering the appropriate group number (e.g. 10). You must confirm the entry with .

### 24.1.1.1 Shop Materials (Parts Information)

The parts assigned to the group are listed in the "Shop Materials Part Information".

KB Part Number	Designation	Footnotes	Vers	Shelf Life
A 000 986 06 50	PRIMING STICK "TOUCH-UP PENCIL, NON-METALLIC -----	050		099
A 000 986 00 50	. TOUCH UP PENCIL, NON-MET. GREEN BEIGE, NO.1000	050,100		036
A 000 986 00 50	. TOUCH UP PENCIL, NON-MET. LIGHT BEIGE, NO.1181	050,100,099		036
A 000 986 00 50	. TOUCH UP PENCIL, NON-MET. BROOD YELLOW, NO.1212	050,100		036
* A 000 986 00 50	. TOUCH UP PENCIL, NON-MET. AUTUMN BEIGE, NO.1430	050,100,099		036
A 000 986 00 50	. TOUCH UP PENCIL, NON-MET. SAND BEIGE, NO.1444	050,100		036
A 000 986 00 50	. TOUCH UP PENCIL, NON-MET. SAND COLORED, GLOSSY, NO.1464	050,100		036
A 000 986 00 50	. TOUCH UP PENCIL, NON-MET. COLORADO BEIGE, NO.1470	050,100		036
A 000 986 00 50	. TOUCH UP PENCIL, NON-MET. MAPLE YELLOW, NO.1606	050,100		036
A 000 986 00 50	. TOUCH UP PENCIL, NON-MET. MIMOSA YELLOW, NO.1618	050,100		036
A 000 986 00 50	. TOUCH UP PENCIL, NON-MET. LIGHT IVORY, NO.1623	050,100		036
A 000 986 00 50	. TOUCH UP PENCIL, NON-MET. PUEBLO BEIGE, NO.1651	050,100		036

EPC4E132

The operation and functionality of the list corresponds to that of the "Parts Information".

📖 see Section "17.1 Parts Information for Standard Illustrated Pages".

## 24.2 About DC EPC

This submenu displays the following information:

- Copyright
- Release (software version)
- CD edition (month/year)



You cannot make any entries here.

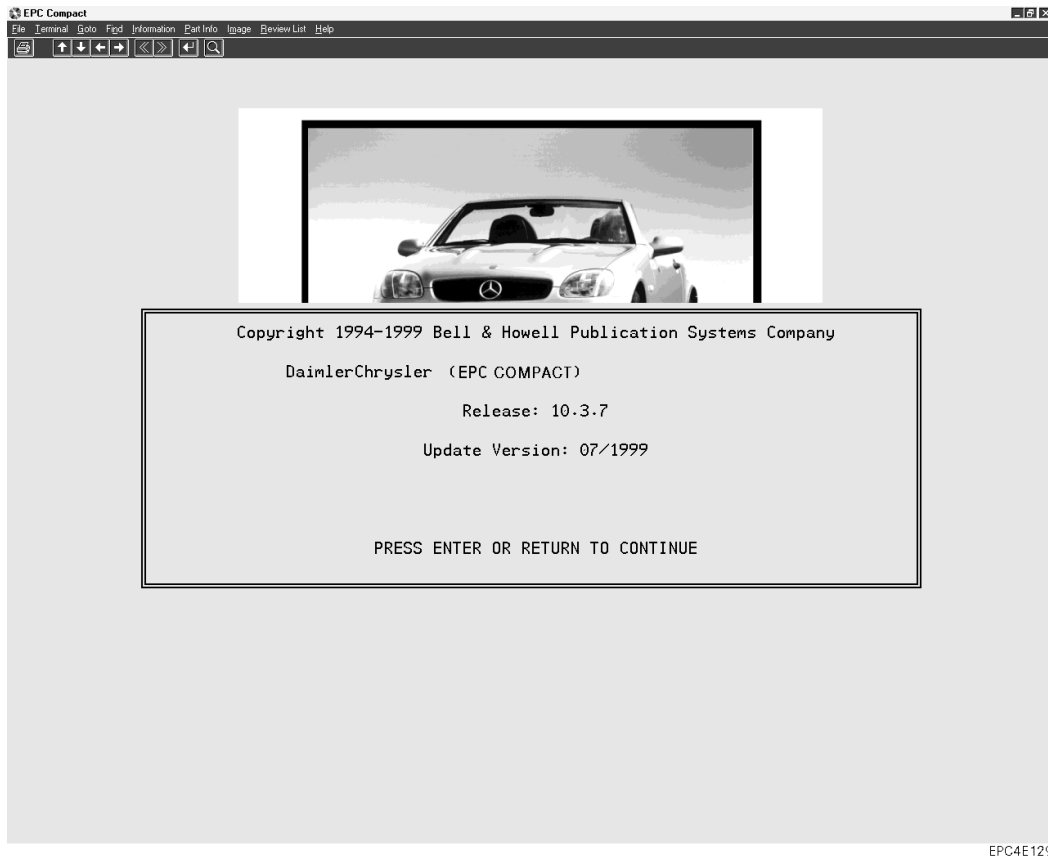

**Index****A**

Abbreviation 19  
About DC EPC 86, 90  
access authorization 32  
Accessories part number 55, 60, 79  
Action Button 17  
Activating a list entry 22  
Add 79  
Add Part Number 62, 63, 79  
Add Part Qty 80  
Add Parts 10  
Agg 13  
Aggregate Index 44  
All 53  
All records 9  
All records - F6 53  
Alt key 5  
AMG part number 55, 60, 79  
Application Index 9, 86  
Arrows 49  
Automatic Transmission 56

**B**

background color 85  
basic EPC settings 8  
Basics 3  
blank illustrated page 50  
BM 2  
BM/SA 9

**C**

Callout 55  
Cat. 12  
Catalogue Index 34  
CD edition 90  
CD Release 1  
CD-ROM 2  
Change Code 62, 66  
Change Designation 62, 64  
Change Quantity 62, 65  
Change Remarks 62, 68  
Chassis 9, 12  
Chassis Number 29  
Class 12  
CLEAR CURRENT LIST 71  
Clear Current List 75  
Close 78  
Closing a submenu 23  
CODE 12  
Code 55, 61  
Code letter 55, 60  
CODE/SA 12  
Color Scheme 85  
Configuration 8  
Control Elements 15  
Copy 77  
COPY A LIST 71  
Copy a List 75

Copyright 90  
Cursor key down 11  
Cursor key left 11  
Cursor key right 11  
Cursor key up 11  
Cursor keys 4

**D**

Data Card 36  
Data Card Ctrl 9  
Data Filter 9  
DATACARD SA FILTERING 41  
Date 77  
DBCP Configuration 85  
Deactivating a list entry 22  
DEFAULT FILTER LEVELS 42  
default settings 85  
Default Values 85  
Delete 5  
DELETE A SAVED LIST 72  
Delete a Saved List 76  
Delete Code 62, 67  
DELETE FOLDER 72  
Delete Folder 76  
Delete Remarks 62, 69  
Design part number 55, 60, 79  
Designation 55, 60  
Displaying Images/Text 82  
DK 2, 12  
DP 2  
Duplicate Part 59

**E**

Enlarge illustrated page 51  
Enlarging an illustrated page 49  
Enlarging Illustrated Pages 51  
Enter 4  
Enter Callout 49  
Enter Footnote Number 58  
EPC 2  
EPC Access Paths 26  
EPC Initial Screen 29  
EPC Message Line 7, 14  
ES Code Input 81  
ES1/ES2 CODE 81  
ES1/ES2 CODES 63  
ES-CODE 2  
existing folder 72  
Exit 9

**F**

Fast access 26, 29  
File 8  
File/Print 83  
File/Print screen 83  
File/Print window 83  
Filter 13, 33  
Filter Menu 40  
Find 9  
Find SA 9

Finding SAs 39  
 Fkey map 10  
 footer text 85  
 Footnote number 58  
 Footnotes 9, 55, 58  
 Footnotes window 58  
 From 77  
 Function keys 4

## G

GA 2  
 GM 2  
 Goto 9  
 GR 2  
 GR/SA 12  
 Group 12  
 Group Index 9

## H

hardcopy 83  
 Help 25  
 Hiding/Showing Illustrated Pages 82  
 Home 4

## I

ID 2  
 Illustrated Page 48, 51  
 Image 9, 49  
 Image Text 9  
 Information 9  
 Information Area 7, 12  
 Information Field 15, 49  
 Information Page 37  
 Input field 19  
 Input Fields 16  
 Insert 4  
 installation location 50  
 Inventory 9

## K

KB 2, 55, 60  
 keyboard 4

## L

Left mouse button 3  
 Left-hand Steering 56  
 List 10  
 List entry 19  
 List Menu 10, 62  
 List Update 70  
 List Utilities 71  
 LL 2

## M

magnify box 85  
 Magnify Box Size 85  
 magnifying glass 49  
 Mechanical Transmission 56  
 MENU 61  
 Menu Bar 6, 8

MOD 13  
 Model 12  
 MODEL FILTERING 40  
 Model Index 33  
 Model Info 9  
 Model no. 30  
 Model Overview 35  
 Moving a submenu 23

## N

NB 2, 56  
 NEW 74  
 new folder 72  
 No datacard available 14  
 NO FILTERING 42  
 No matching parts are available 14  
 Non-Illustrated Parts may be Available 14, 49

## O

OFF 13  
 OPTIONAL WITH 55  
 ORDER 78  
 Order 61  
 order form 77  
 Order List 77  
 Order number 77

## P

Page Arrow 18  
 Page down 5, 11  
 Page up 5, 11  
 Part Info 9  
 Part Number 55, 60  
 Parts Information 54  
 Parts Information for SA Illustrated Pages 57  
 Parts Information for Standard Illustrated Pages 54  
 Parts Order 72, 77  
 Pop-Up Menus 24  
 Print 5, 8, 11, 78  
 Print Message 85  
 Print Screen 8  
 Print Setup 8  
 Print Window 8  
 Print/Page setup 83  
 Printing 83  
 Printing illustrated pages 50, 52  
 prtorders.txt 77

## Q

Qty 56, 61

## R

Recall a Saved List 71, 75  
 Release 1, 90  
 Remarks 61  
 REPLACED BY 55  
 Return 4, 11  
 Review List 10  
 Right mouse button 3  
 Right-hand Steering 56

RL 2

## S

SA 2, 12

SA AVAIL 13

SA catalogue. 9

SA Index 9

SA Index (Special Versions Index) 45

SA Parts Information 54

SA STROKE filtering 41

SA Stroke Index 46

Sales designation 12

Save As 77

Save Current List 71, 72

Save Current List to a New Folder 74

Save Current List to an Existing Folder 72

Save List Then SYSX 84

Screen Areas 6

Screen item number 48

Scrolling by page 18

Selected Parts List 60, 61

SELECTED PARTS LIST - Folder 61

Selection bar 21

Selection List 19

Selection Lists with Individual Selections 21

Selection Lists with Input Fields 19

Selection Lists with Multiple Selections 22

SERIAL NUMBER FilterING 41

Setup Defaults 85

Shop Material Group Index 88

Shop Materials 86

Shop Materials (Class Index) 87

Shop Materials (Parts Information) 89

Signature 78

software version 1, 90

Special version. 12

Standard Group Index 43

Standard part number 55, 60, 79

Standard parts catalogue 9

Standard Sub-Group Index 47

Star 22, 54, 60

STD 13

Steering Filtering 41

Sub-group Index 9

Sub-group information 49

Submenus 23

Supplier number 55, 60, 79

SYSX Menu 84

SYSX Without Saving Current List 84

## T

Tab key 4

Terminal 9

This Illustration is not Available at this Time 50, 52

To 77

Tool part number 55, 60, 79

Toolbar 6, 11

transmission Filtering 42

Type no. 30

## U

Update List 62

Using the Keyboard 4

Using the Mouse 3

UTIL 61, 71

## V

VB 2, 12

Veh. Ident. No. 61

Vehicle ID no. 29

vehicle ID number 61

Vers 56

version codes 56

View List 10

VIN 2

## W

Warning 32

WDB 30

Windows header 6

Work area 7

Workstation folder 73

Workstation name 73

World Manufacturer Code 29, 30, 31

## Z

Zoom 11

Zoom Ctrl 9

Zoom function 49