



F4

AR47.10-P-7000B

Removing and installing fuel level gauge sensor





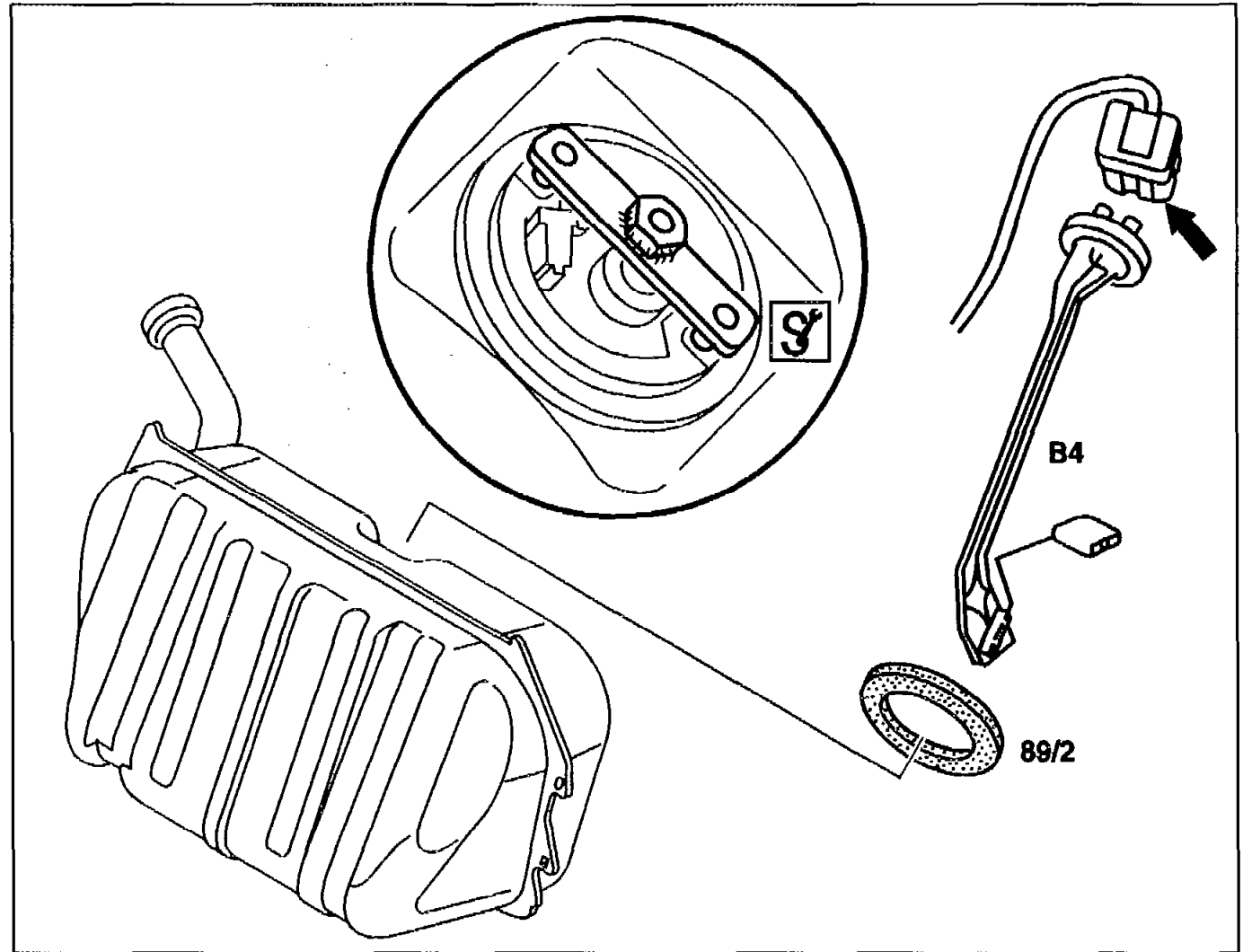

9.12.94

MODEL 210.004 /006 /010 /017 /020 /025 /035 /037 /045 /053 /055 /063 /065 /070 /074 /081 /082

89/2 Seal

B4 Fuel gauge sensor



	Removing, installing		
 Danger!	Risk of explosion from ignition. Risk of poisoning from inhaling and swallowing fuel. Risk of injury as a result of fuel coming into contact with skin and eyes.	No fire, naked flame or smoking. Pour fuels only into suitable and appropriately marked containers. Wear protective clothing when handling fuel.	AS47.00-Z-0001-01A D17
1	Empty fuel tank, fill	 If fuel tank is full, pump out about 8 liters.	AR47.10-P-4001B H1
2	Remove trim for fuel tank in the trunk		
3	Unplug coupling (arrow) for fuel gauge sensor (B4) (and pressure sensor,  only)	 Fuel gauge sensor (B4) and pressure sensor form a unit. Secure electric cable to prevent it slipping off.	
4	Open bayonet lock of fuel gauge sensor (B4)		210 589 01 07 00
5	Take out fuel gauge sensor (B4)	 Installation: replace seal (89/2). Oil to facilitate installation.	
6	Install in the reverse order		

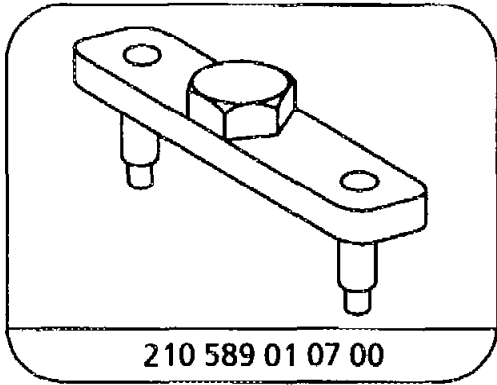

Pin wrench