



J2

AR09.10-P-1050GA

Removing and installing air cleaner

21.4.98

**ENGINE 111.943 /944 /947 /973 /975****Model 170 with engine 111.943/973**

Arrow Connector at actuator

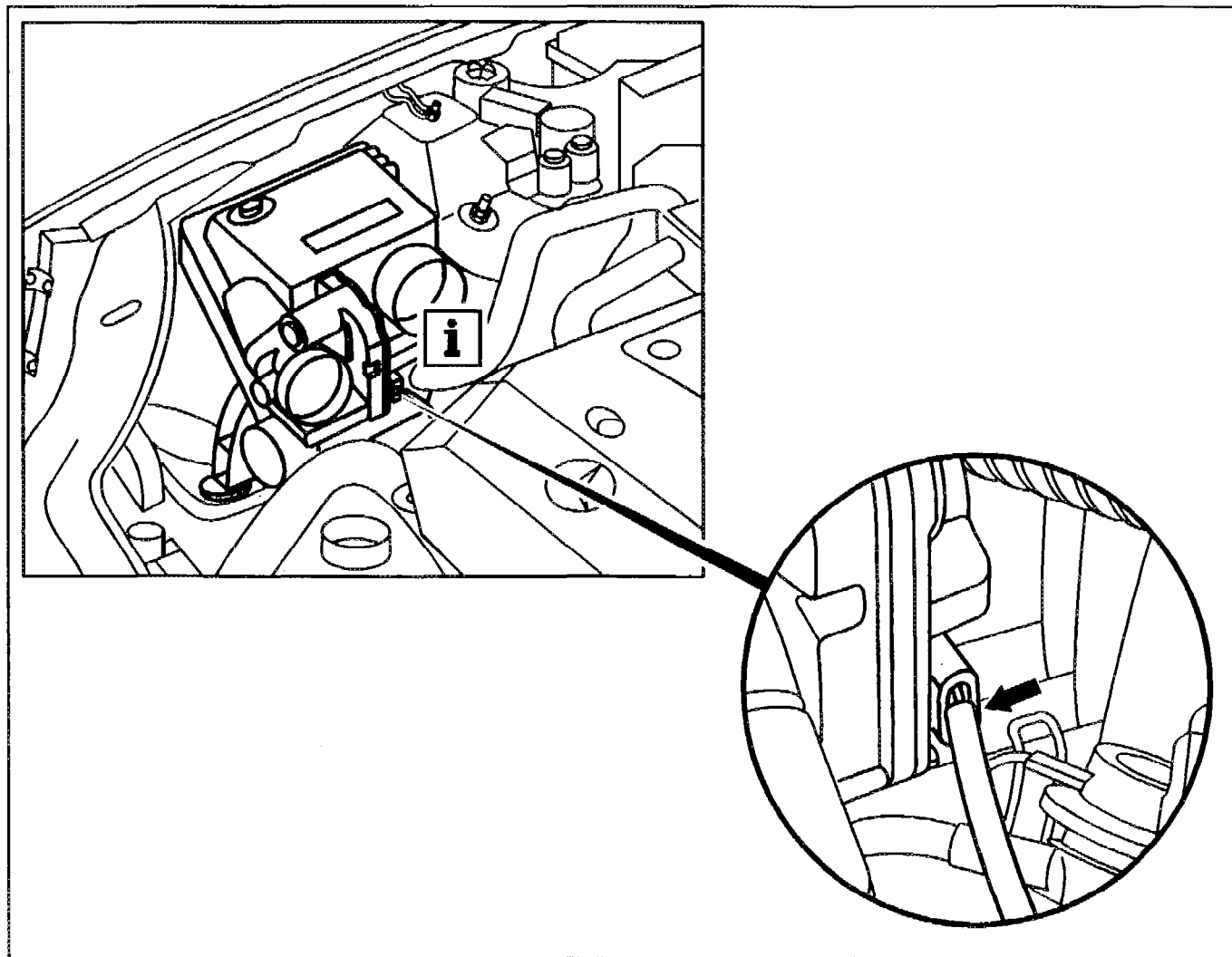



**Model 202, 208 with engine 111.944/975**

**Arrow Connector at actuator**

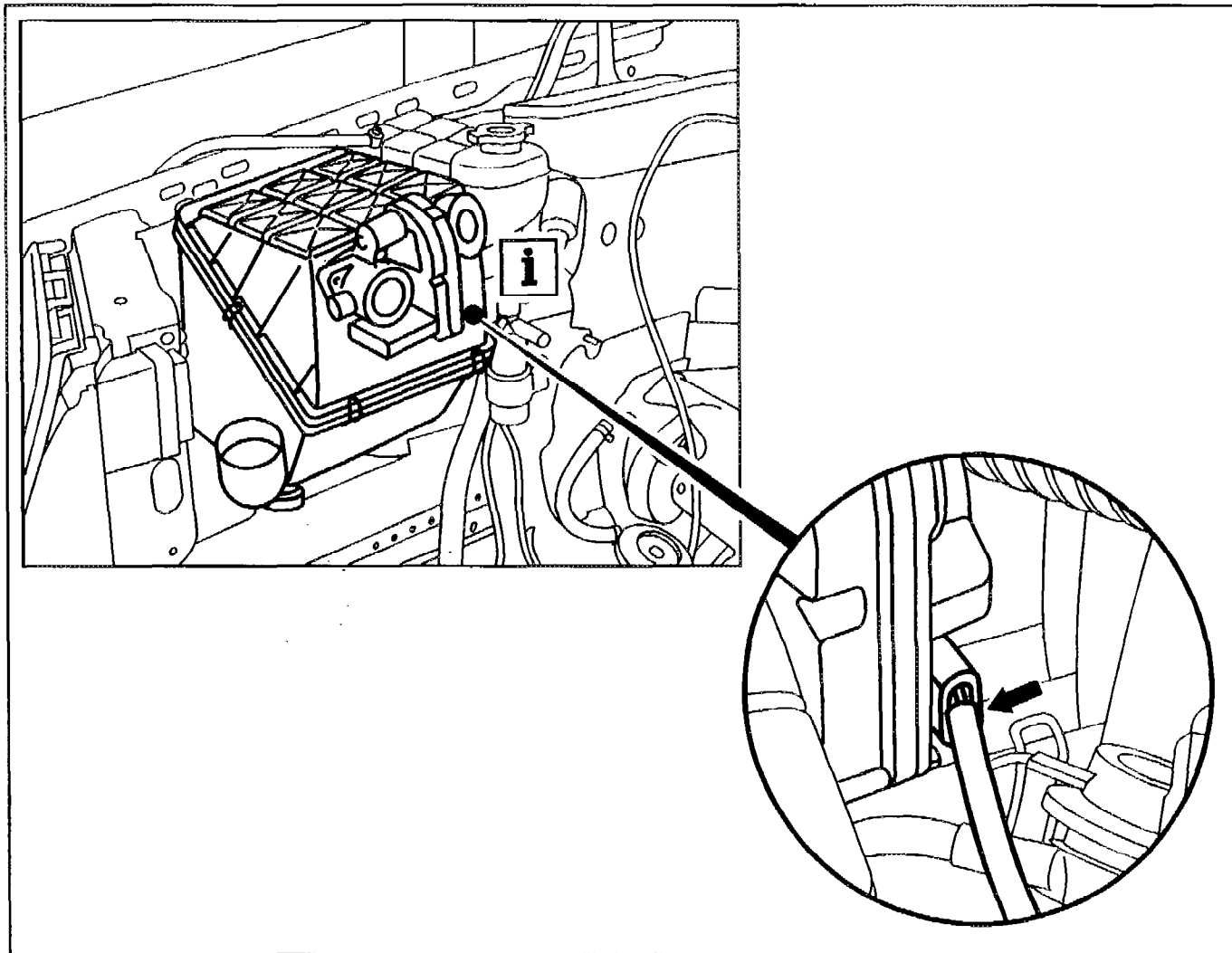

**Model 210 with engine 111.947**

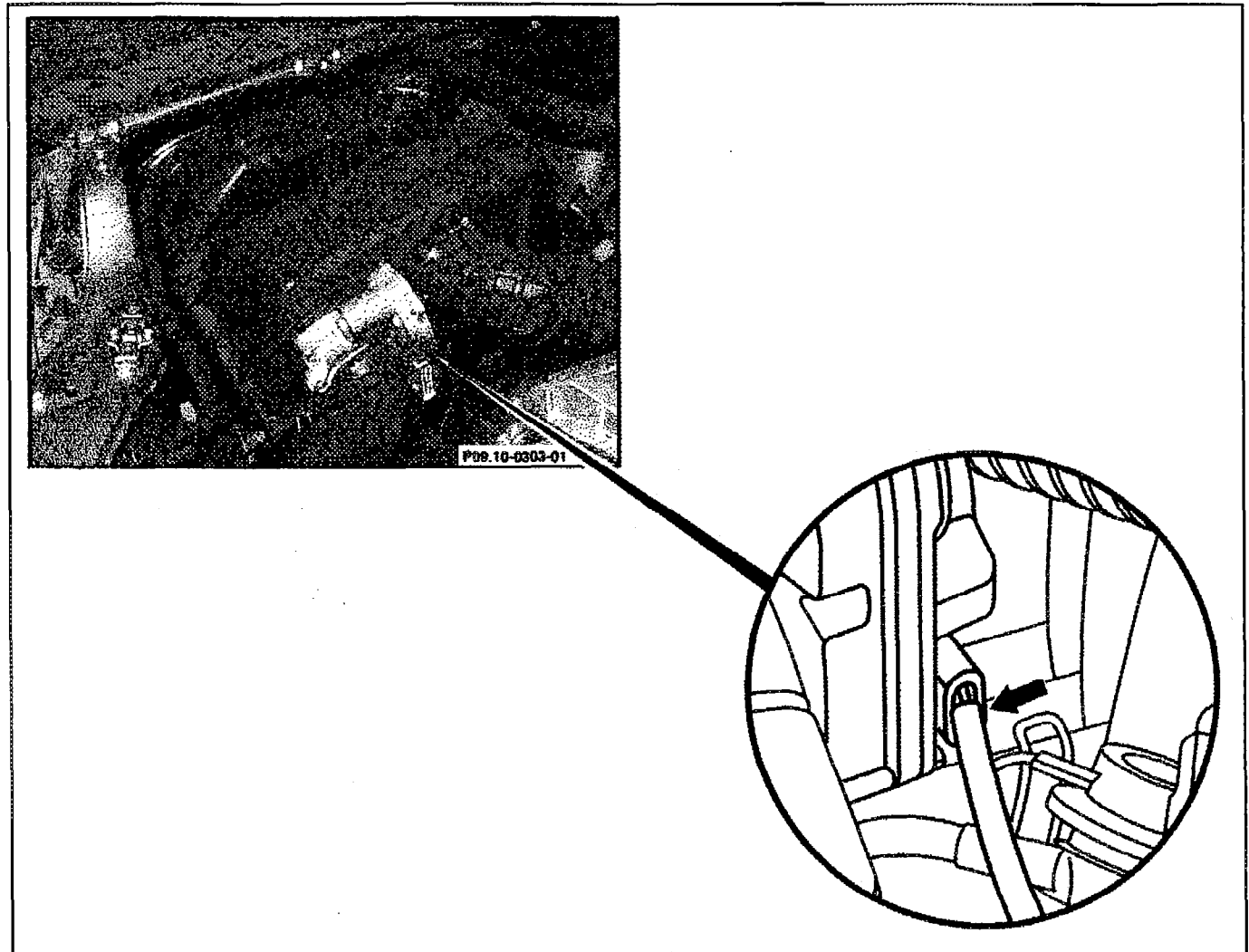

**Arrow Connector at actuator**



P09.10-0300 06

Fig. item, etc.	Work instructions		
<b>i</b>	Connector at actuator	First of all raise catch at connector housing to unplug the connector	



	Pins of air cleaner	Press into rubber bush	
	Cyclone separator	<b>Model 170, 202, 208, 210</b> Retrofitting not possible, fit filter felt or foam to air cleaner element	